

Dental drill noise reduction using a combination of Active Noise Control, Passive Noise Control and Adaptive Filtering

Erkan Kaymak^a, Mark Atherton^a, Ken Rotter^b, Brian Millar^c
^aBrunel University, School of Engineering and Design, ^bLondon South Bank University, ^cKing's College London Dental Institute at Guy's, King's and St Thomas'
^aKingston Lane
Uxbridge UB8 3PH
United Kingdom

ABSTRACT

Dental drills produce a characteristic high frequency, narrow band noise that is uncomfortable for patients and is also known to be harmful to dentists under prolonged exposure. It is therefore desirable to protect the patient and dentist whilst allowing two-way communication. A solution is to use a combination of the three main noise control methods, namely, Passive Noise Control (PNC), Adaptive Filtering (AF) and Active Noise Control (ANC). This paper discusses the application of the three methods to reduce dental drill noise while allowing two-way communication. Experimental setup for measuring the noise reduction by PNC is explained and results from different headphones and headphone types are presented. The implementation and results of an AF system using the Least Mean Square (LMS) algorithm are shown. ANC requires a modification of the LMS algorithm due to the introduction of the electro-acoustical cancellation path transfer function to compensate for the delays introduced by the control system. Therefore a cancellation path transfer function modeling method based on the filtered reference LMS (FXLMS) algorithm is presented along with preliminary results of the implementation.

1 INTRODUCTION

Dental drill noise is well known for its uncomfortable characteristic. It has been reported that 50% of the US population does not visit the dentist regularly and up to 15 % avoid much needed dental care due to anxiety and fear [1, 2]. Hence dental treatment cannot be performed effectively and there is also a risk of hearing damage to the dentist due to prolonged exposure, which was reported in [3, 4]. Blocking the patient's hearing from the surrounding acoustic field is not a solution as communication between the dentist and patient is required. It is therefore desirable to protect the patient and dentist whilst allowing two-way communication, for which a headphone-type system is a viable solution [5]. There is no significant work known to the authors that deals with the reduction of dental drill noise using cancellation technologies.

Re-establishing good communication between the dentist and patient can be achieved through a combination of three noise cancellation technologies, namely, Passive Noise Control (PNC), Adaptive Filtering (AF) and Active Noise Control (ANC). Figure 1 shows a schematic drawing of the dental treatment situation and the methods used to control the noise. As can be seen, ANC and PNC are methods for controlling the acoustical path of the noise whereas AF is used to cancel the noise in the electrical path. PNC is a physical barrier used to cancel high frequency acoustic noise but is less effective for low frequency noise. ANC uses anti-noise to cancel acoustic noise and is normally limited to low frequency because of physical and computational limitations [6, 7]. However, narrowband dental drill noise

^a Email address: erkan.kaymak@brunel.ac.uk

presents an opportunity to apply ANC for high frequency noise [8] in a controlled small area such as in a headphone. Using ANC and PNC in a headphone will hinder communication and hence the AF of the electrical path must be present in the system. Hence the desired signal picked up by the microphone (e.g. dentist’s speech), which is contaminated by the drill noise, is cleaned by the AF algorithm and only the dentist speech is heard by the patient.

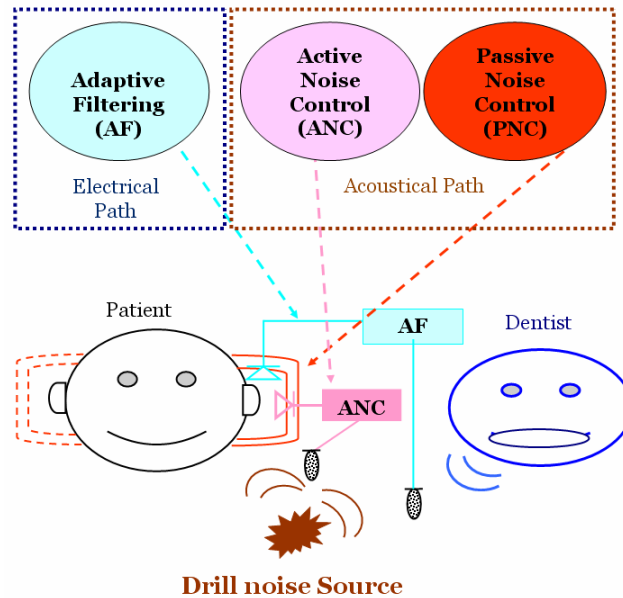

Figure 1 Combined noise cancellation methods for dental comfort

This paper is structured as follows. The second section describes the experimental setup for PNC experiments, showing and discussing the PNC control performances for four different headphones available on the market. The third section discusses the LMS AF algorithm implementation and presents the real-time AF results. In the fourth section the use of the filtered reference LMS algorithm (FXLMS) is described and preliminary results are shown and discussed.

2 PASSIVE NOISE CONTROL MEASUREMENTS

An Ear & Cheek Simulator (ECS) (Figure 2) was used to obtain frequency response plots. It represents the section of a head important for realistic reproduction of the acoustic properties of the ear of an average human head [9]. The ECS consists of a pinna, an ear simulator and a ½-inch pressure microphone. The microphone picks up the controlled noise before and after mounting a headphone. An electromotor-driven dental drill was used as a noise source. Figure 3 a) shows the frequency responses of the ECS for the drill rotating at its highest speed (200000rev/min ~ ca. 3.33 kHz). The ECS was placed 45 cm away from the drill and 2 seconds of readings were taken. Figure 3 b) shows a comparison of the frequency responses of the ECS and a Sennheiser tie clip microphone. A difference of approximately 5 dB can be observed at the main peak at circa 3.3 kHz and the difference over the frequency band is due to the responses of the ECS and the Sennheiser microphone. It is also clear that both microphones pick up exactly the same peak frequency, so that in terms of frequency the measurements are accurate.



Figure 2 G.R.A.S. Sound and Vibration Ear and Cheek simulator

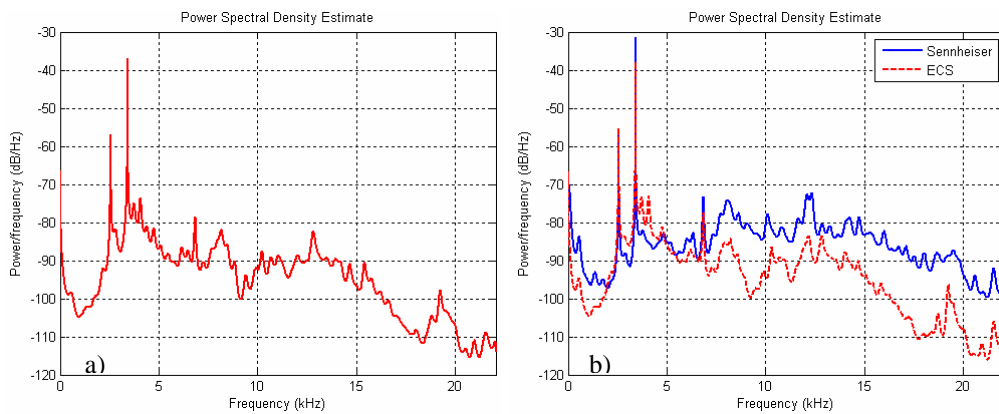
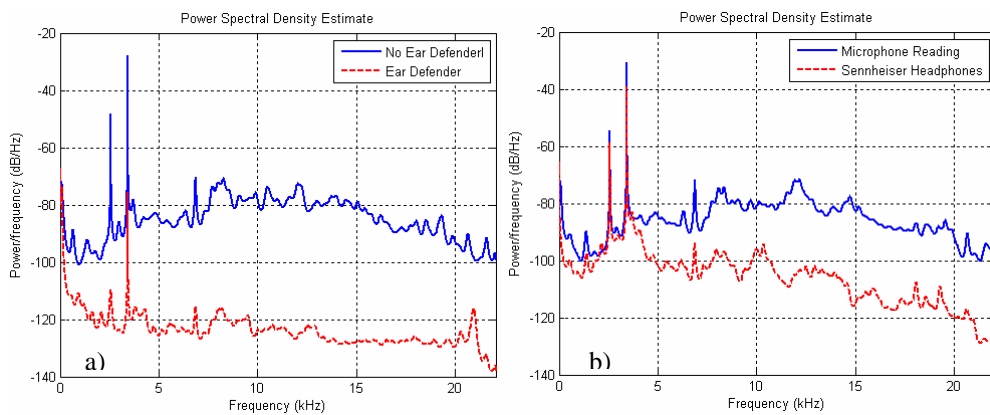

Figure 3 a) Frequency response of ECS b) Frequency responses of ECS and Sennheiser MKE 2 P-C

Further measurements were performed with a standard industrial ear defender, open Sennheiser open headphones (HD 555), Sennheiser noise cancellation headphones (PXC 250) and BOSE headphones (Model QC-1). Figures 4 a) to d) show power spectral density plots before and after mounting the headphones and ear defender on to the ECS. A noise reduction over the whole frequency band can be seen except for the Sennheiser HD 555 Headphones.



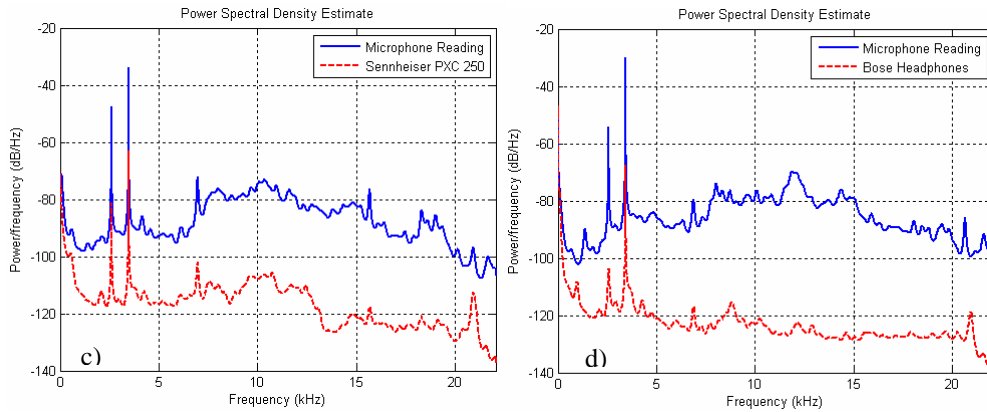

Figure 4 Power spectral density for a) Ear Defender b) Sennheiser Headphones HD555 (open headphones) c) Sennheiser PXC 250 (noise cancellation headphones) d) Bose Headphones (noise cancellation headphones)

Figure 5 shows the passive noise reduction of the main peak for each ear defender and headphone type. It shows the average of 10 (N=10) readings and the variation.

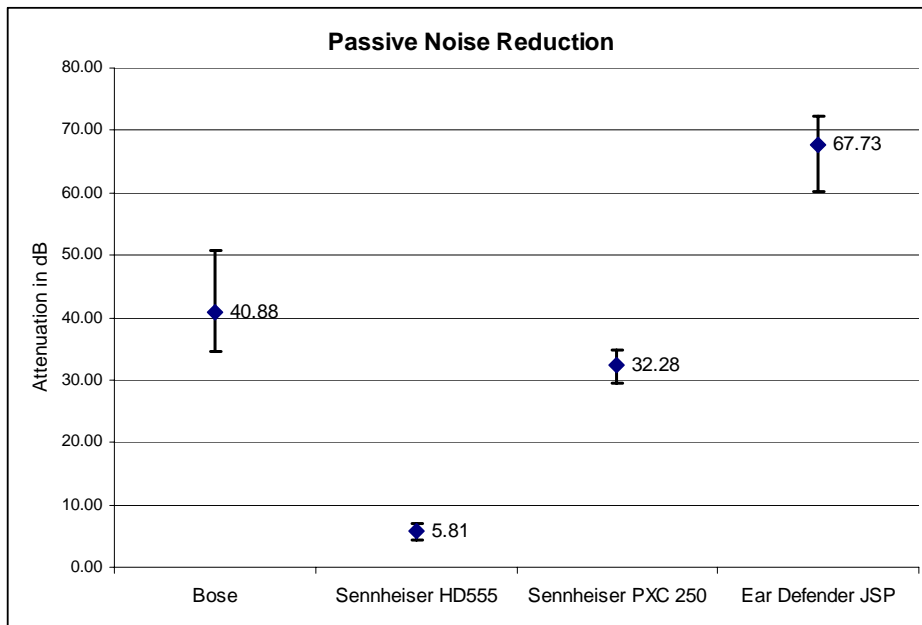

Figure 5 Passive Noise Attenuation and measurement variation

It can be seen that the circum-aural Bose Headphones have a very good passive filtering property with a peak noise attenuation of over 40 dB. Although the measurement variation reaches 24% of the mean the attenuation is still sufficient. The Sennheiser HD555 headphones show the poor passive noise cancellation properties expected, an average attenuation of 5.8 dB, as they are open headphones and are not meant to control external noise. The Sennheiser supra-aural noise cancellation headphones (PXC 250) also show a good passive noise cancellation performance with an average attenuation of 32 dB and a measurement variation of less than 10%. The JSP ear defender behaves as expected with the best passive noise reduction. It shows an attenuation of more than 65 dB and the maximum measurement variation is about 11%.

3 REAL TIME ADAPTIVE FILTERING IMPLEMENTATION

3.1 TI TMS320C6713 Digital Signal Processor

The Texas Instruments TMS320C6713 DSK starter kit was used as the processing unit for the processing of the signals both in implementing the AF and ANC system. It is a low cost stand-alone DSP development platform that can be used to develop applications for the TMS320C67xx DSP family [11]. It includes the C6713 floating-point digital signal processor (DSP) and a 32 bit stereo codec (AIC23) for input and output (Fig. 8). The AIC23 codec uses a sigma-delta technology that provides analogue to digital conversion (ADC) and digital to analogue conversion (DAC) and has variable sampling rates from 8 kHz to 96 kHz. It includes 16 MB synchronous dynamic random access memory (SDRAM) and 256 kB of flash memory. Furthermore it includes two inputs (LINE IN, MIC IN) and two output ports (LINE OUT, HEADPHONE). The DSK operates at a frequency of 225 MHz and has got a single power supply of 5 V. The architecture of the TMS320C6713 is well suited to numerically intensive algorithms. The internal memory is structured so that a total of eight instructions can be called every cycle. For example with a clock rate of 225 MHz, the C6713 is capable of calling eight 32-bit instructions every $1/(225 \text{ MHz})$ or 4.44 ns [18]. The C6713 (C671, C6711) belongs to the family of floating-point processors, whereas the C62xx and C64xx belong to the family of the C6x fixed-point processors. The C6713 is also capable of fixed-point processing and it enables the developer to update the algorithm to a fixed-point calculation after running under floating point on the same DSK.

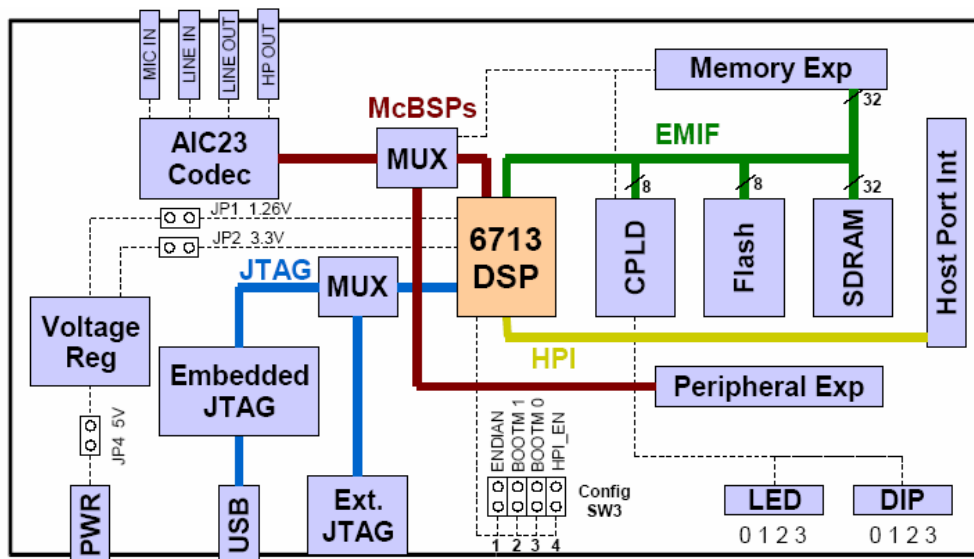

Figure 6 Block Diagram of TI TMS320C6713 DSK

Only one input port of the LINE IN or MIC IN ports can be used and hence only two channels are available. Therefore, a DUAL3006 audio daughter card was connected to the peripheral expansion of the DSK in order to have more than two channels. The DUAL3006, provides four synchronized 16-bit ADC and DAC channels input ports (4 input channels) and two output ports (4 output channels).

3.2 Adaptive Filtering

An adaptive digital filter (AF) consists of an adaptive algorithm, which updates the adjustable coefficients of the digital filter. The digital filter is in most cases a finite impulse response (FIR) filter due to its simplicity and guaranteed stability. The Least Mean Square (LMS) updating algorithm is the most widely used AF algorithm due to its ease of implementation and effective computational properties [10]. Figure 7 shows the Block diagram of an adaptive algorithm as a noise canceller.

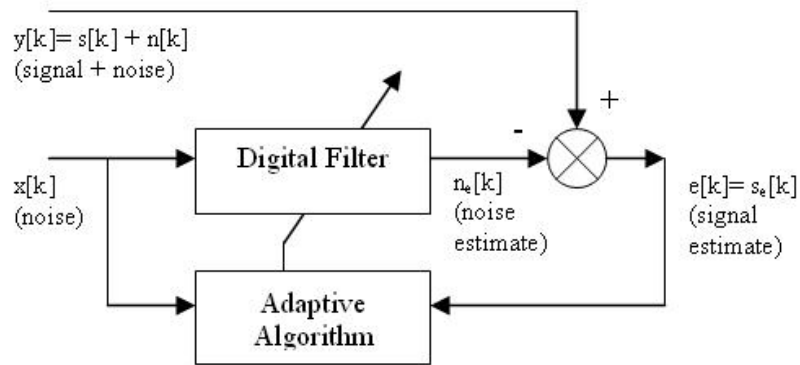

Figure 7 Block diagram of an adaptive filter as a noise canceller

The reference signal governs the behaviour of the algorithm, i.e. when the reference signal is narrow band noise the AF becomes to an adaptive notch filter [6]. AF removes the narrow band noise picked up by the reference microphone. The Digital Signal Processor is used to filter the electrical signal in real-time. It uses the standard LMS algorithm as shown in equation 1.

$$w[k + 1] = w[k] + 2\mu e[k]x[k] \quad (1)$$

where μ is the step size factor (convergence rate factor) and $e[k]$ the error signal (equation 2), which is the difference between the adaptive filter output $n_e[k]$ (equation 3) and the desired microphone signal $y[k]$. $x[k]$ is the reference noise signal picked up by a reference microphone.

$$e[k] = y[k] - n_e[k] = s[k] + n[k] - n_e[k] \quad (2)$$

$$n_e[k] = \sum_{i=0}^{N-1} w_i[k]x[k] \quad (3)$$

The aim of the adaptive algorithm is to minimise the error signal. This is done by estimating an optimum filter output $n_e[k]$, which is ideal when it becomes $n[k]$. The convergence factor μ governs the speed convergence. Figure 8 shows the result of real-time adaptive narrow band filtering of an electromotor driven handpiece noise. It can be seen that at least 30 dB peak noise reduction can be obtained on the main peak at approximately 3.3 kHz.

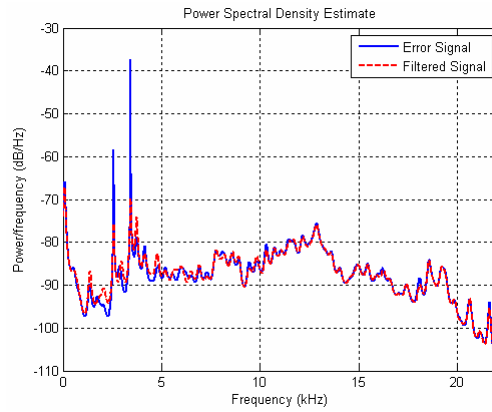

Figure 8 Results of the adaptive notch filtering implementation

4 ACTIVE NOISE CONTROL

ANC uses the principle of destructive interference which is superimposing waves of the same amplitude as the noise but in anti-phase. ANC for drill noise requires (i) narrow band noise, (ii) small application area of interest and (iii) a fixed zone of interest (Figure 5), due to the physical restrictions involved in the implementation of ANC when dealing with higher frequencies [12].

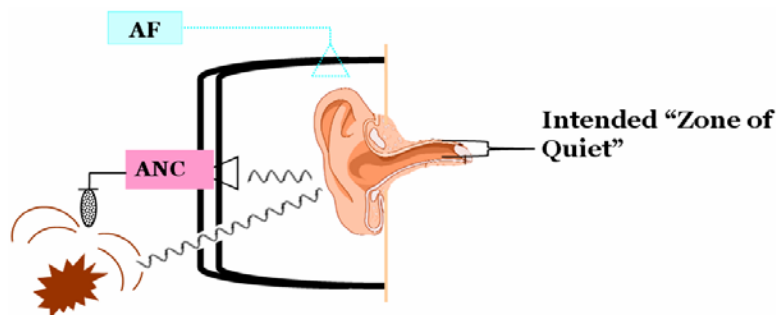

Figure 9 Active Noise Control implementation and intended zone of quiet

In ANC an enhanced version of the LMS algorithm is used, namely the FXLMS algorithm, where the reference signal is filtered by an additional filter, $S_c(z)$, before it enters the adaptive filter. The block diagram in figure 11 shows the consideration of the cancellation path transfer function $S(z)$. There are two ways of estimating the cancellation path transfer function $S_c(z)$. One is the off-line cancellation path transfer function modelling technique and the other is the on-line modelling technique [6]. The off-line modelling technique is easier to implement but it has the disadvantage that it does not include the changes in the cancellation path such as changes in temperature, humidity and distance. Figure 10 a) shows the error signal convergence to a minimum and figure 10 b) shows the filter output converging to an optimum noise estimate for the off-line modelling technique. Figure 11 shows the on-line modelling technique proposed in [6]. It introduces a random noise generator that generates a white noise, which is uncorrelated with the primary noise. In a cascaded LMS algorithm the coefficients of the cancellation path transfer function $S_c(z)$ are calculated. These coefficients are then used to build an Finite Impulse Response (FIR) filter, which filters the reference signal $x(k)$. The on-line technique promises to adapt to the changes in the cancellation path, however it requires more computational power.

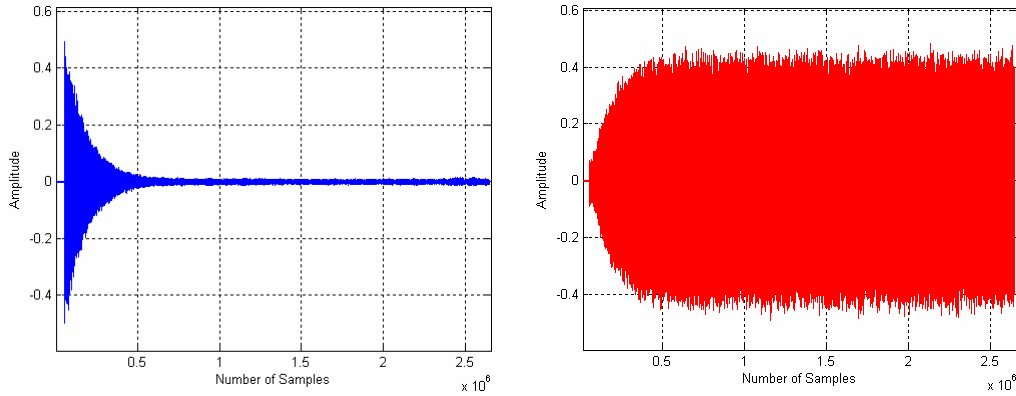

Figure 10 Off-line technique a) Error $e(n)$ convergence b) Filter output $y(n)$

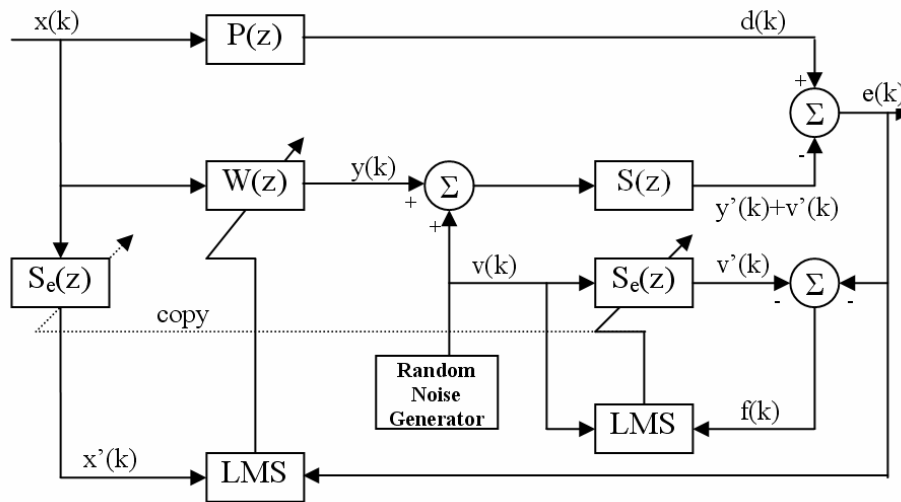

Figure 11 On-line Modeling Technique proposed in [6]

5 CONCLUSIONS AND FURTHER WORK

Passive noise control (PNC) is very effective in reducing the overall frequency band noise as the results of the tests showed. However the peak of the dental drill noise is still perceivable by the patient. Introducing active noise control (ANC) to compensate the PNC attenuation will allow more flexibility in terms of passive design of the headphone, whereas a PNC only solution would be too bulky for use in a dental surgery.

Applying the off-line modeling technique of the ANC implementation has achieved satisfactory error signal convergence. A future step is to implement an on-line cancellation path modeling algorithm in order to adapt the control algorithm to the changes in the cancellation path. However using ANC and PNC will hinder the communication between the dentist and the patient. Therefore adaptive filtering (AF) is implemented to filter out the noise peak in the electrical path whilst not changing the speech in the signal. Results show good attenuation of the noise peak in the electrical signal. The results of all reductions techniques indicate that these techniques can be combined in a headphone system for dental drill noise reduction.

6 REFERENCES

- [1] M Krochak, "What is Dental Phobia? Prevalence and Etiology", Dental Phobia Treatment Center of New York, 1993, (<http://www.dentalfear.net/>)
- [2] M.E.A. Stouthard and J. Hoogstraten, "Ratings of Fears Associated with Twelve Dental Situations," *J Dent Res*, **66**:1175-1178 (1987).
- [3] T. Lehto, "Dentists hearing and exposure to high speed turbine dental drill noise," *Proceedings of Finnish Dental Society*, **86**:115-125 (1990).
- [4] CE Wilson, TK Vaidyanathan, WR Cinotti, SM Cohen, SJ. Wang, "Hearing-damage risk and communication interference in dental practice," *Journal of Dental Research*, **69**; 489-93 (1990).
- [5] E Kaymak, M A Atherton, K R G Rotter, B Millar, "Real-time Adaptive Filtering of Dental Drill Noise using a digital signal processor", *Proceedings of conference on Research and Education in Mechatronics REM2006*, 2006.
- [6] Sen M Kuo., D.R. Morgan., *Active Noise Control systems: algorithms and DSP implementations* (John Wiley & Sons, New York, 1996).
- [7] C.H. Hansen, *Understanding Active Noise Control* (Spon Press, London, 2001).
- [8] E Kaymak, M.A. Atherton, K Rotter, B Millar, "Active Noise Control at High Frequencies", *Proceedings of Thirteenth International Congress on Sound and Vibration*, 2006.
- [9] www.gras.dk
- [10] C.E. Ilfeachor, B.W. Jervis, *Digital Signal Processing, A Practical Approach* (Addison Wesley, Suffolk, 1993).
- [11] *TMS320C6713 DSK Technical Reference*, (Spectrum Digital, 2004).
- [12] C.H. Hansen, *Understanding Active Noise Cancellation* (Spon Press, London, 2001).