

CORRELATION OF LABORATORY AND INSTALLED DRAINAGE SYSTEM SOLID
TRANSPORT MEASUREMENTS

SHAUN DAVID BOKOR, B.Tech. (Hons).

A THESIS SUBMITTED TO BRUNEL UNIVERSITY FOR THE DEGREE OF
DOCTOR OF PHILOSOPHY

DRAINAGE RESEARCH GROUP
DEPARTMENT OF BUILDING TECHNOLOGY
BRUNEL UNIVERSITY
UXBRIDGE

AUGUST 1982

CORRELATION OF LABORATORY AND INSTALLED DRAINAGE SYSTEM SOLID
TRANSPORT MEASUREMENTS.

SHAUN DAVID BOKOR, B.Tech. (Hons).

ABSTRACT

The transport of solids in 'horizontal' above ground drainage pipes was the subject of an investigation, based upon the measurement of both sterile 'model' solid velocity and 'live' waste load velocity, aimed at the establishment of a sound basis for the development of a comprehensive empirical drainage design method linked directly to installed drainage system solid transport measurements.

Initial laboratory investigations were directed towards the assessment of various 'model' solid materials, with regard to comparative potential use with respect to drainage research. Results suggested a 'calibration' approach to the development of a design method to be a viable proposition, while a 'direct simulation' approach was found to be impracticable.

Two installed branch drainage systems were monitored, which served male and female W.C. cubicles in the entrance waiting area of a large London hospital. A considerable body of data was compiled with respect to both facility usage patterns and drainage system loading. Transport performance data, classified according to waste load type, was processed to yield comparisons to the general form of relationships previously reported in relation to 'model' solid transport.

It was concluded that the proportional rate of occurrence of the different types of waste load must be a prime consideration in any design method, and the premise that solid deposition should be avoided was confirmed. Solid transport mechanisms, as associated with each of the different types of 'live' waste load material and sterile 'model', were detailed, and the relevance to 'live' waste load performance, of previous 'model' solid transport equations (which suggest 'linear' deceleration over substantial pipe lengths), was demonstrated. The study was concluded with the presentation of specific design performance recommendations, based upon the installed drainage system transport measurements, which data may be employed, initially, as the basis for a 'calibration' approach to laboratory based drainage research, and subsequently, as the basis for a comprehensive empirical drainage design method.

ACKNOWLEDGEMENTS

The work reported was supported by D.H.S.S. Commission Number 981/-/188, and was conducted within the Department of Building Technology at Brunel University.

The author wishes to record his thanks to a number of people for their particular contributions to this work. Primarily, Dr J.A. Swaffield is to be thanked for his expertise and willing assistance, although his personal concern and encouragement were equally invaluable. The advice and assistance of Dr R.H.M. Wakelin was also much appreciated.

Mr John Burkitt provided extremely reliable 'backup' with regard to the identification of faults in the instrumentation systems, and Mr Arthur Lomas provided congenial assistance, during 'On Site' activities, despite the difficult working environment.

Graphics and Secretarial Assistance were most capably provided by Mr Paul Brooks and Ms Mandy Feldon respectively, whose contributions greatly relieved the final pains of report compilation, and were therefore most gratefully received.

Although far too many to mention individually, other members of staff, at both Brunel University and Greenwich District Hospital, are to be thanked for each of their particular contributions.

CONTENTS		<u>Page</u>
Abstract.		ii
Acknowledgments.		iii
Contents.		iv
List of Figures.		xi
Terminology, Notation and Abbreviations.		xxv
1.	INTRODUCTION	1.
2.	PREVIOUS RESEARCH	4.
2.1	The Importance of Research in the Development of Drainage Design Over the Last Fifty Years.	5.
2.2	A Review of Research Relating Directly to Solid Transport Studies, both Completed and in Progress.	11.
2.2.1	A Pilot Study.	11.
2.2.2	Mechanism of Waste Solid Transport.	12.
2.2.3	Steep Gradient Discharge Pipes.	14.
2.2.4	Reduced Flush Volume.	14.
2.2.5	W.C. Discharge Geometry.	15.
2.2.6	Analytical Approach to Solid Transport.	16.
2.3	Conclusion.	17.
3.	IDENTIFICATION OF THE FORCES ACTING ON A SOLID IN TRANSPORT.	18.
3.1	Development of Empirical Relationships Governing Waste Solid Transport in Drainage Systems.	20.
3.2	Analytical Approaches to the Solution of the Forces Acting on a Solid.	23.

	<u>Page</u>
4. APPARATUS AND INSTRUMENTATION - DEVELOPMENT FOR THE LABORATORY.	26.
4.1 The Water Closet (W.C.) and Support Rig.	27.
4.2 Pipes and Fittings.	27.
4.3 Discharge Pipe Support Rig.	28.
4.4 Flushing Mechanism.	29.
4.5 Measurement of Flush Ahead of Solid.	30.
4.6 Measurement of Solid Velocity.	31.
4.7 Experimental Method.	35.
4.8 Data Handling and Presentation of Results.	35.
5. FAECES, AND SUBSTITUTE 'MODEL' SOLIDS.	37.
5.1 Defecation and Faecal Matter - the Available Information.	38.
5.1.1 Frequency of Defecation.	38.
5.1.2 Per Capita Output of Excreta	39.
5.1.3 Chemical Constituents.	40.
5.1.3.1 Water.	40.
5.1.3.2 Bile Pigments.	40.
5.1.3.3 Carbohydrate.	40.
5.1.3.4 Protein.	41.
5.1.3.5 Mucus.	41.
5.1.3.6 Fat.	42.
5.1.3.7 Ammonia.	42.
5.1.3.8 Vitamins.	42.
5.1.3.9 Minerals and Trace Elements.	42.
5.1.4 Physical Properties.	42.
5.1.4.1 Colour (Pigments).	42.
5.1.4.2 Odour.	43.
5.1.4.3 Form and Consistency.	43.

		<u>Page</u>
5.2	Important Parameters in Respect of 'Sterile Models'.	44.
5.2.1	Specific Gravity.	44.
5.2.2	Shape, Size and Number.	44.
5.2.3	Water Absorption.	46.
5.2.4	Surface Roughness.	46.
5.2.5	Durability to Friction.	46.
5.2.6	Rigidity.	46.
5.2.7	Elasticity.	47.
5.3	Materials Considered as Substitutes for 'Live' Solid Waste.	47.
5.3.1	Flour Putty.	47.
5.3.2	Potter's Clay.	48.
5.3.3	Polyvinylalcohol Powder.	48.
5.3.4	Polyvinylalcohol Sponge.	49.
5.3.5	Fakazell.	52.
5.3.6	Sanitary Protection Products.	52.
6.	DISCUSSION OF LABORATORY RESULTS.	54.
7.	LABORATORY STUDY CONCLUSIONS.	63.
8.	APPARATUS AND INSTRUMENTATION - DEVELOPMENT FOR 'SITE-WORK'.	67.
8.1	Pipes and Fittings.	68.
8.2	Discharge Pipe Support System.	70.
8.3	Measurement of Flush Ahead of Solid.	72.
8.4	Measurement of Solid Velocity.	73.
8.5	Cistern Operation Monitoring.	79.

	<u>Page</u>
8.6	Ancillary Equipment. 82.
8.7	Data Handling and Presentation of Results. 83.
9.	MONITORING OF IN SITU INSTALLATIONS. 86.
9.1	Choice of Suitable Hospital. 87.
9.2	Survey of Hospital Facilities. 89.
9.2.1	The Initial Survey. 89.
9.2.2	The Wider Survey. 91.
9.3	Facilities Chosen for Full Monitoring Programme. 92.
9.3.1	The Area Serviced. 92.
9.3.2	Sanitary Services Provided. 93.
9.3.3	Peculiarities of Facility Usage. 94.
9.3.4	Regulatory Assessment of Facilities. 94.
9.3.5	Scales of Provision of Sanitary Appliances. 95.
9.4	Installation of U.P.V.C. Pipework and Monitoring Equipment. 98.
9.4.1	Standard of Workmanship. 98.
9.4.2	Method of Installation. 98.
9.4.3	Effects of Limited Space. 101.
9.5	Monitoring Procedures and Operating Difficulties. 102.
9.5.1	Daily Monitoring Period. 102.
9.5.2	Regulations Concerning Floor Void Working. 103.
9.5.3	Void Security. 103.
9.5.4	Setting Cistern Discharge Volumes. 104.
9.5.5	Cistern Operation Monitoring. 105.
9.5.6	Waste Solid Velocity Monitoring. 106.
9.5.7	Instrumentation Difficulties. 107.
9.5.8	Problems of Cistern Operation and Usage. 108.
9.5.9	Human Interference. 110.

	<u>Page</u>
10. DISCUSSION OF 'SITE-WORK' RESULTS.	112.
10.1 Facility Usage Patterns.	113.
10.1.1 The Female Facility.	113.
10.1.1.1 Average Usage During 'On-Site' Periods.	113.
10.1.1.2 Comparative Usage of Individual W.C.s.	114.
10.1.1.3 Comparative Usage on Individual Weekdays.	115.
10.1.1.4 Comparative Weekend Usage.	116.
10.1.1.5 Area Population and Peak Demand.	117.
10.1.1.6 Success Displayed in Meeting Demand.	119.
10.1.2 The Male Facility.	125.
10.1.2.1 Average Usage During 'On-Site' Periods.	125.
10.1.2.2 Comparative Usage of Individual W.C.s.	126.
10.1.2.3 Comparative Usage on Individual Weekdays.	127.
10.1.2.4 Comparative Weekend Usage.	129.
10.1.2.5 Area Population and Peak Demand.	130.
10.1.2.6 Success Displayed in Meeting Demand.	134.
10.2 Flush Content and Solid Deposition.	144.
10.2.1 Simultaneous Discharges.	145.
10.2.2 Flush Content.	146.
10.2.2.1 Classification of Solids.	146.
10.2.2.2 Distinctive Flush Types.	149.
10.2.2.3 Constituent Solids - Number and Material Type.	152.
10.2.2.4 Constituent Solids - Load Assessment.	157.
10.2.3 Solid Deposition.	165.
10.3 Transport of 'Live' Waste Solids.	169.
10.3.1 Flow Observations.	169.
10.3.1.1 Positional Advantage of Faecal Solids.	169.

	<u>Page</u>
10.3.1.2	Modulative Nature of 'Zone 2' Deceleration. 170.
10.3.1.3	The Multi-Solid Flush - Interactive Mechanisms. 174.
10.3.1.4	Re-evaluation of the 'Zone 3' Condition. 179.
10.3.2	System Calibration. 184.
10.3.2.1	Pipe Gradient. 185.
10.3.2.2	W:C. Design. 189.
10.3.2.3	W.C. Discharge Geometry. 197.
10.3.2.3.1	W.C. Orientation. 197.
10.3.2.3.2	Vertical 'Pipe-drop', (and Re-evaluation of the 'Zone 1' Condition). 199.
10.3.2.4	Cistern/Flush-pipe Geometry. 205.
10.3.2.5	W.C. Venting. 212.
10.3.2.6	Calibration Tests. 216.
10.3.3	Deceleration Characteristics. 234.
10.3.3.1	Accuracy of Estimation. 235.
10.3.3.2	Dominance of Toilet/Tissue-paper Solids. 237.
10.3.3.3	Mobile Nature of Toilet/Tissue-paper Solids. 240.
10.3.3.4	Comparative Performance of Male and Female Waste Loads. 257.
10.3.3.5	Relevance to Above Ground Drainage Design. 260.
11.	CONCLUSIONS AND FURTHER WORK. 277.
12.	BIBLIOGRAPHY. 285.
13.	FIGURES. 292.
APPENDIX I	426.
A1	MASTER DREG COMPUTER PROGRAM. 427.
A1 - 1	Listing of Variable Names. 427.
A1 - 2	Data Controls. 429.
A1 - 3	Flow Diagram (Master DREG). 430.
A1 - 4	Flow Diagram (Subroutine STATIS). 433.
A1 - 5	Program Listing. 435.
A1 - 6	Sample Printout. 439.

	<u>Page</u>
APPENDIX II	441.
A2	442.
MASTER GREENWICH COMPUTER PROGRAM	
A2 - 1	442.
Listing of Variable Names.	
A2 - 2	444.
Data Controls.	
A2 - 3	445.
Program Listing	
A2 - 4	451.
Sample Printout.	
APPENDIX III	459.
A3	460.
DATABANK OF INSTALLED SYSTEM SOLID TRANSPORT MEASUREMENTS.	
A3 - 1	461.
Comp. Check No. 1500, Female Main-Line Installation (W.C.3), Gradient 1:150.	
A3 - 2	477.
Comp. Check No. 1600, Female Branch-Line Installation (W.C.2), Gradient 1:150.	
A3 - 3	489.
Comp. Check No. 2500, Female Main-Line Installation (W.C.3), Gradient 1:200.	
A3 - 4	503.
Comp. Check No. 2600, Female Branch-Line Installation (W.C.2), Gradient 1:200.	
A3 - 5	519.
Comp. Check No. 3500, Male Main-Line Installation (W.C.5), Gradient 1:150.	
A3 - 6	528.
Comp. Check No. 3600, Male Branch-Line Installation (W.C.6), Gradient 1:150.	

LIST OF FIGURES

FIGURE No.		<u>Page</u>
3/1	Schematic representation of the forces involved in determining solid motion.	293.
3/2	Schematic representation of the forces acting on the solid and the fluid annulus within a control volume ABCD.	294.
3/3	Schematic representation of the forces acting on the solid, where the solid itself forms the limits of the control volume.	295.
4/1	Twyfords P-trap, 109° outlet, 'back-inlet' W.C. pan, (B.S.1213).	296.
4/2	Armitage Shanks, V1206 Contour, P-trap 'back-inlet', W.C. pan, (B.S. 3402).	296.
4/3	W.C. support rig, (laboratory study).	297.
4/4	Inlet to discharge pipe, (laboratory study).	298.
4/5	Outlet from discharge pipe, (laboratory study).	299.
4/6	W.C./Cistern configuration, (laboratory study).	300.
4/7	Method of pipe support, (laboratory study).	301.
4/8	Automatic flushing mechanism, (laboratory study).	301.
4/9	Photo cell/light source arrangement, (laboratory study).	302.
4/10	Variation of 'change-over points', with pulse amplitude.	303.
4/11	Circuit diagram of optically triggered time logging equipment, O.T.T.L.E.	304.
4/12	Timing diagram of O.T.T.L.E.	305.
4/13	Internal view of O.T.T.L.E.	306.
4/14	Test rig instrumentation table, (laboratory study).	306.
5/1	Faecal weights around the world.	307.
5/2	Resume of the major chemical components of human faeces.	308.
5/3	Influence of various foods and medicaments on the colour of the stool.	308.

	<u>Page</u>
5/4	Specific gravities of various materials considered as substitutes for excreta in laboratory tests. 308.
5/5	A variety of the different 'models' produced from P.V.A. powder, (with and without 'filler' materials). 309.
5/6	Specification of P.V.A. sponge 'model' solids. 310.
5/7	Early attempts at producing P.V.A. sponge 'models', solids pictured in a 'wet state' condition. 311.
5/8	Original P.V.A. sponge blocks, pictured in a 'wet state' condition. 312.
5/9	Original P.V.A. sponge blocks, pictured in 'dry state' condition. 312.
5/10	P.V.A. sponge 'models', as employed in laboratory investigations, pictured in 'wet state' condition. 313.
5/11	P.V.A. sponge 'models', as employed in laboratory investigations, pictured in 'dry state' condition. 313.
6/1	Variations in performance resulting with particular variations in the dimensional parameters of maternity pad 'model' solids. 314.
6/2	Variations in performance resulting with particular variations in length (mass) of maternity pad 'model' solid. 314.
6/3	Variations in performance resulting with particular variations in width (mass) of maternity pad 'model' solid. 315.
6/4	Variations in performance resulting with particular variations in thickness (mass) of maternity pad 'model' solid. 315.
6/5	Variations in performance resulting with particular length/thickness adjustments (for constant mass) to the maternity pad 'model' solid. 316.
6/6	Variations in performance resulting with particular length/width adjustments (for constant mass) to the maternity pad 'model' solid. 316.

	<u>Page</u>
8/1	Inlet to discharge pipe, ('on-site'). 317.
8/2	Connection of 'branch-line' W.C. pan to main straight length of monitored pipework, ('on-site'). 317.
8/3	Outlet from main straight length of monitored pipework, ('on-site'). 318.
8/4	Connection of newly installed U.P.V.C. pipework to original C.I. main, ('on-site'). 318.
8/5	Method of pipe support, ('on-site'). 319.
8/6	Test rig instrumentation table, ('on-site'). 319.
8/7	'Zoned' pen recorder trace out - sample segment. 320.
8/8	Photo cell/light source arrangement, ('on-site'). 321.
8/9	Schematic layout of 'terminal box'. 322.
8/10	Installed 'float switch', ('on-site'). 323.
8/11	Schematic layout of four channel 'cistern operation monitoring console'. 324.
8/12	Cable to 'float switch', concealed inside 15 mm. (I.D.) U.P.V.C. pipework. 325.
8/13	Solid identification code, (for 'live' waste loads.) 326.

		<u>Page</u>
9/1	Installed U.P.V.C. service to nurses' education department.	327.
9/2	Plan of cafeteria/circulatory area, as serviced by the monitored facilities.	328.
9/3	Plan of female facility and installed services.	329.
9/4	Plan of male facility and installed services.	329.
9/5	Installed Armitage Shanks V1207, 'top-inlet', S-trap' W.C. pan.	330.
9/6	W.C./Cistern configuration, ('on-site').	331.
9/7	Installed urinals.	332.
9/8	Original C.I. service pipework, to monitored facilities.	333.
9/9	Adapted service pipework layout, to monitored facilities.	334.
9/10	Example of floor void congestion.	335.
9/11	Original C.I. service to male facility, 'cut-back' to accommodate U.P.V.C. service.	335.
9/12	General view of installed U.P.V.C. service to female facility.	336.
9/13	General view of installed U.P.V.C. service to male facility.	336.
9/14	135° U.P.V.C. junction arrangement on male service system.	337.
9/15	135° U.P.V.C. junction arrangement on female service system.	338.
9/16	Operating mechanism of 'dual-flush' cistern.	339.
9/17	General view of female facility.	340.
9/18	General view of male facility.	340.
9/19	General view of the 'cafeteria' section of the area serviced by the monitored facilities.	341.
9/20	General view of the 'circulatory' section of the area serviced by the monitored facilities.	341.

		<u>Page</u>
10/1	Total W.C. usage per mean weekday, 8 a.m. to 3 p.m. at the female facility (all four appliances).	342.
10/2	Mean weekday usage, per individual female facility W.C. pan.	343.
10/3	Graphical presentation of mean weekday usage, per individual female facility W.C. pan.	344.
10/4	Comparative overall usage of individual female facility W.C. pans.	345.
10/5	Graphical presentation of comparative overall usage of individual female facility W.C. pans.	345.
10/6	Average usage of female facility W.C. pans per individual weekday.	346.
10/7	Graphical presentation of average usage of female facility W.C. pans per individual weekday.	347.
10/8	Comparative overall usage of female facility W.C. pans per individual weekday.	348.
10/9	Graphical presentation of comparative overall usage of female facility W.C. pans per individual weekday.	348.
10/10	Mean occupation times for sanitary fittings.	349.
10/11	Relative usage of sanitary appliances in offices during peak periods.	349.
10/12	Demand rates in office buildings.	349.
10/13	Distribution of occupation times for female W.C. cubicles.	350.
10/14	Total W.C. usage per mean weekday, 8 a.m. to 3 p.m. at the male facility.	350.
10/15	Average male facility W.C. usage during 'on-site' periods.	351.
10/16	Mean weekday usage per individual male facility W.C. pan.	352.
10/17	Average usage of male facility W.C. pans per individual weekday.	352.
10/18	Comparative overall usage of individual male facility W.C. pans.	353.

		<u>Page</u>
10/19	Comparative overall usage of male facility W.C. pans per individual weekday.	353.
10/20	Graphical presentation of comparative overall usage of individual male facility W.C. pans.	353.
10/21	Graphical presentation of comparative overall usage of male facility W.C. pans per individual weekday.	353.
10/22	Rate of occurrence of distinctive flush types.	354.
10/23	Male facility flush content - with respect to level of demand over half-hourly periods.	355.
10/24	Graphical presentation of male facility flush content - with respect to level of demand over half-hourly periods.	355.
10/25	Male facility flush content - with respect to level of demand over hourly periods.	356.
10/26	Graphical presentation of male facility flush content - with respect to level of demand over hourly periods.	356.
10/27	Graphical presentation of the observed and predicted proportional rates of occurrence of the different flush types.	357.
10/28	Summary of the mean numbers of particular and total solids per flush type.	358.
10/29	Relative numbers of distinctive solid types as constituents in 'faecal' flushes, in respect to the number of solids at evacuation from the W.C., for the different gradient observations at the female facility.	359.
10/30	Relative numbers of distinctive solid types as constituents in 'faecal' flushes, in respect to the number of solids at evacuation from the W.C., for each of the male and female facility observations.	360.
10/31	Graphical presentation of the proportional rate of occurrence of distinctive solid types as constituents in 'faecal' flushes, in respect to the number of solids at evacuation from the W.C., for gradient 1:150 at the female facility.	361.
10/32	Graphical presentation of the proportional rate of occurrence of distinctive solid types as constituents in 'faecal' flushes, in respect to the number of solids at evacuation from the W.C., for gradient 1:200 at the female facility.	361.

	<u>Page</u>
10/33	Graphical presentation of the proportional rate of occurrence of distinctive solid types as constituents in 'faecal' flushes, in respect to the number of solids at evacuation from the W.C., for gradient 1:150 at the male facility. 362.
10/34	Summary of the exact material composition of both 'normal' and 'rogue' solids, as contained at evacuation from the W.C. by all monitored 'single' flushes. 363.
10/35	Faecal solid descriptive data. 364.
10/36	Comparative toilet/tissue-paper solid length. 364.
10/37	Comparative toilet/tissue-paper solid thickness. 365.
10/38	Comparative toilet/tissue-paper solid shape. 365.
10/39	Variations in 'faecal volume' estimation with chronological grouping of 'faecal' flush data. 366.
10/40	Graphical presentation of variations in 'faecal volume' estimation with chronological grouping of 'faecal' flush data. 367.
10/41	Data relating to deposits encountered and/or solids deposited, at the female facility and at gradient 1:150, with respect to the number of solids per flush at evacuation from the W.C. 368.
10/42	Data relating to the number and material type of solids evacuated and solids deposited, at the female facility and at gradient 1:150, by those 'single' 'faecal' flushes which did not encounter any previous stoppages. 369.
10/43	Data relating to the number of solids evacuated and solids deposited, at the female facility and at gradient 1:150, by those 'single' 'non-faecal' flushes which did not encounter any previous stoppages. 370.
10/44	Data relating to the number of solids evacuated and solids deposited, at the female facility and at gradient 1:150, by those 'single' 'faecal' flushes which contained faecal material only, and which did not encounter any previous stoppages. 370.

	<u>Page</u>
10/45	Data relating to deposits encountered and/or solids deposited, at the female facility and at gradient 1:200, with respect to the number of solids per flush at evacuation from the W.C. 371.
10/46	Data relating to the number and material type of solids evacuated and solids deposited, at the female facility and at gradient 1:200, by those 'single' 'faecal' flushes which did not encounter any previous stoppages. 372.
10/47	Data relating to the number of solids evacuated and solids deposited, at the female facility and at gradient 1:200, by those 'single' 'non-faecal' flushes which did not encounter any previous stoppages. 373.
10/48	Data relating to the number of solids evacuated and solids deposited, at the female facility and at gradient 1:200, by those 'single' 'faecal' flushes which contained faecal material only, and which did not encounter any previous stoppages. 373.
10/49	Data relating to deposits encountered and/or solids deposited, at the male facility and at gradient 1:150, with respect to the number of solids per flush at evacuation from the W.C. 374.
10/50	Data relating to the number and material type of solids evacuated and solids deposited, at the male facility and at gradient 1:150, by those 'single' 'faecal' flushes which did not encounter any previous stoppages. 375.
10/51	Data relating to the number of solids evacuated and solids deposited, at the male facility and at gradient 1:150, by those 'single' 'non-faecal' flushes which did not encounter any previous stoppages. 376.
10/52	Data relating to the number of solids evacuated and solids deposited, at the male facility and at gradient 1:150, by those 'single' 'faecal' flushes which contained faecal material only, and which did not encounter any previous stoppages. 376.
10/53	Summary of waste solid deposition. 377.
10/54	Relative position of faecal solids in female facility 'faecal' flushes. 378.
10/55	Relative position of faecal solids in male facility 'faecal' flushes. 378.

	<u>Page</u>
10/56 Individual solid velocity profiles of a range of 'Fastidia Mini-pads', as recorded in the laboratory at gradient 1:80.	379.
10/57 Individual solid velocity profiles of a range of 'Johnson & Johnson Panty Shields', as recorded in the laboratory at gradient 1:80.	379.
10/58 Individual solid velocity profiles of a range of 'Fastidia Mini-pads', as recorded at the male facility at gradient 1:150, (W.C.5.)	380.
10/59 Individual solid velocity profiles of a range of 'Johnson & Johnson Panty Shields', as recorded at the male facility at gradient 1:150 (W.C.5.)	380.
10/60 Individual solid velocity profiles of a range of 'Fastidia Mini-pads', as recorded at the female facility at gradient 1:200, (W.C.3.)	381.
10/61 Individual solid velocity profiles of a range of 'Johnson & Johnson Panty Shields', as recorded at the female facility at gradient 1:200, (W.C.3.)	381.
10/62 Individual solid velocity profiles of a range of toilet/tissue-paper solids, each of which occurred as the sole content of its own flush, as recorded at the female facility at gradient 1:150, (W.C.3.)	382.
10/63 Individual solid velocity profiles of a range of toilet/tissue-paper solids, each of which occurred as the sole content of its own flush, as recorded at the female facility at gradient 1:200, (W.C.3.)	382.
10/64 Individual solid velocity profiles of a range of 'maternity pads', as recorded in the laboratory at gradient 1:80.	383.
10/65 Individual solid velocity profiles of the contents of selected flushes, each of which contained two off toilet/tissue-paper solids, as recorded at the female facility at gradient 1:150, (W.C.3.)	383.
10/66 Individual solid velocity profiles of the contents of selected flushes, each of which contained two off toilet/tissue-paper solids, as recorded at the female facility at gradient 1:150, (W.C.3.)	384.
10/67 Individual solid velocity profiles of the contents of selected flushes, each of which contained two off toilet/tissue-paper solids, as recorded at the female facility at gradient 1:200, (W.C.3.)	384.

	<u>Page</u>
10/68 Individual solid velocity profiles of the contents of a three solid flush, each solid being of toilet/tissue-paper, as recorded at the female facility at gradient 1:200, (W.C.3.)	385.
10/69 Individual solid velocity profiles of the contents of a four solid flush, each solid being of faecal material, as recorded at the female facility at gradient 1:200, (W.C.3.)	385.
10/70 Individual solid velocity profiles of the contents of a mixed 'faecal' flush (four solids), as recorded at the female facility at gradient 1:150, (W.C.3.)	386.
10/71 Individual solid velocity profiles of the contents of a mixed 'faecal' flush (five solids) as recorded at the female facility at gradient 1:150 (W.C.3.)	386.
10/72 Individual solid velocity profiles of the contents of a mixed 'faecal' flush (four solids), as recorded at the female facility at gradient 1:200, (W.C.3.)	387.
10/73 Individual solid velocity profiles of the contents of a mixed 'faecal' flush (four solids), as recorded at the female facility at gradient 1:150, (W.C.3.)	387.
10/74 Individual solid velocity profiles of a selection of toilet/tissue-paper solids, each of which occurred as the sole content of its own flush, as recorded at the female facility at gradient 1:200, (W.C.3.)	388.
10/75 Re-examination of maternity pad performance for 'zone 3' flow conditions.	389.
10/76 Individual solid velocity profiles of a range of faecal solids, each of which occurred as the 'trailing' solid of a mixed content 'faecal' flush, as recorded at the female facility at gradients 1:150 and 1:200, (W.C.3.)	390.
10/77 Individual solid velocity profiles of a selection of faecal solids, each of which occurred as the 'trailing' solid of a mixed content 'faecal' flush, as recorded at the female facility at gradients 1:150 and 1:200, (W.C.2. and W.C.3.)	391.
10/78 Average 'maternity pad' velocity profiles, as recorded, over a range of different gradients, using a vented Twyford's B.S.1213 'P-trap' W.C. pan.	392.

	<u>Page</u>
10/79	Average 'maternity pad' velocity profiles, as recorded, over a range of different gradients, using a vented Twyfords European 'P-trap' W.C. pan. 392.
10/80	Average 'maternity pad' velocity profiles, as recorded, over a range of different gradients, using an un-vented Armitage Shanks 'P-trap' W.C. pan. 393.
10/81	Average 'maternity pad' velocity profiles, as recorded, at gradients 1:60 and 1:100, using an un-vented Armitage Shanks 'S-trap' W.C. pan. 393.
10/82	Average 'maternity pad' velocity profiles, as recorded, at gradients 1:60 and 1:100, using an un-vented Twyfords 'P-trap' W.C. pan. 394.
10/83	Average 'maternity pad' velocity profiles, as recorded, at gradients 1:60 and 1:100, using an un-vented Twyfords 'S-trap' W.C. pan. 394.
10/84	Average velocity profiles of the 'maternity pad and 3 Kleenex towel' waste load, as recorded, over a range of different gradients, using an un-vented Armitage Shanks 'P-trap' W.C. pan. 395.
10/85	Average velocity profiles of the 'maternity pad and 3 Kleenex towel' waste load, as recorded, at gradients 1:60 and 1:100, using an un-vented Armitage Shanks 'S-trap' W.C. pan. 395.
10/86	Average velocity profiles of the 'maternity pad and 3 Kleenex towel' waste load, as recorded at, gradients 1:60 and 1:100, using an un-vented Twyfords 'P-trap' W.C. pan. 396.
10/87	Average velocity profiles of the 'maternity pad and 3 Kleenex towel' waste load, as recorded, at gradients 1:60 and 1:100, using an un-vented Twyfords 'S-trap' W.C. pan. 396.
10/88	Summary of works relating to the effects, upon 'model' solid transport, of variations in W.C. type and vent condition. 397.
10/89	W.C. orientation and waste solid transport. 398.
10/90	Individual 'zone 1' solid velocity profiles of an envelope of 'maternity pads', as recorded in the laboratory at gradient 1:80. 399.
10/91	W.C./cistern geometry - average velocity profiles for each of the 'control', 'horizontal length' (of flush pipe) and 'bore' (of flush pipe) tests. 400.

		<u>Page</u>
10/92	W.C./cistern geometry - a range of individual 'modulative' solid velocity profiles, as component to the 'control' test.	400.
10/93	W.C./cistern geometry - a range of individual 'modulative' solid velocity profiles, as component to the 'horizontal length' (of flush pipe) test.	401.
10/94	W.C./cistern geometry - a range of individual 'modulative' solid velocity profiles, as component to the 'bore' (of flush pipe) test.	401.
10/95	Average 'maternity pad' velocity profiles, as recorded, over a range of different gradients, using a vented Armitage Shanks 'P-trap' W.C. pan.	402.
10/96	Average 'maternity pad' velocity profiles, as recorded, at gradients 1:60 and 1:100, using a vented Armitage Shanks 'S-trap' W.C. pan.	402.
10/97	Average 'maternity pad' velocity profiles, as recorded, at gradients 1:60 and 1:100, using a vented Twyfords 'P-trap' W.C. pan.	403.
10/98	Average 'maternity pad' velocity profiles, as recorded, at gradients 1:60 and 1:100, using a vented Twyfords 'S-trap' W.C. pan.	403.
10/99	Average velocity profiles of the 'maternity pad + 3 Kleenex towel' waste load, as recorded, over a range of different gradients, using a vented Armitage Shanks 'P-trap' W.C. pan.	404.
10/100	Average velocity profiles of the 'maternity pad + 3 Kleenex towel' waste load, as recorded, at gradients 1:60 and 1:100, using a vented Armitage Shanks 'S-trap' W.C. pan.	404.
10/101	Average velocity profiles of the 'maternity pad + 3 Kleenex towel' waste load, as recorded at gradients 1:60 and 1:100, using a vented Twyfords 'P-trap' W.C. pan.	405.
10/102	Average velocity profiles of the 'maternity pad + 3 Kleenex towel' waste load, as recorded, at gradients 1:60 and 1:100, using a vented Twyfords 'S-trap' W.C. pan.	405.
10/103	Summary of the effects of 'venting' W.C. discharge.	406.
10/104	The 'venting' configurations employed by Wakelin (1978).	407.

	<u>Page</u>
10/105	Average 'Johnson & Johnson Panty Shield' velocity profiles, as recorded during 'installed system' calibration procedures. 408.
10/106	Average 'Fastidia Mini-pad' velocity profiles, as recorded during 'installed system' calibration procedures. 408.
10/107	Average 'maternity pad' velocity profiles, as recorded, at gradient 1:80, during laboratory based investigations of the effects of an incorporated 92½° bend. 409.
10/108	Average 'trailing solid' velocity profiles of 'non-faecal' flushes, as recorded at the 'in situ' installations. 409.
10/109	Average 'trailing solid' velocity profiles of 'faecal' flushes, as recorded at the 'in situ' installations. 410.
10/110	Summary of useful descriptive information concerning the mean waste content of each distinct and separate test sample, as recorded at the 'in situ' installations, of successfully monitored 'single' flushes which did not encounter previous deposits. 411.
10/111	Comparative assessment of toilet/tissue-paper content between 'faecal' and 'non-faecal' flushes. 412.
10/112	Distribution of 'non-faecal' flush 'trailing solid' velocities, for each of the different velocity measurement points, as recorded, at gradient 1:150, at the female 'main-line' installation (W.C.3). 413.
10/113	Distribution of 'faecal' flush 'trailing solid' velocities, for each of the different velocity measurement points, as recorded, at gradient 1:150, at the female 'main-line' installation. 414.
10/114	Variation, in 'trailing solid' velocity distribution, with distance from the input device. 415.
10/115	Overall measure of 'trailing solid' velocity distribution. 416.
10/116	Assessment of 'combined sample' velocity distribution. 417.
10/117	Basic solid velocity data, as recorded, at gradient 1:150 at the female 'on-site' installation. 418.

		<u>Page</u>
10/118	Basic solid velocity data, as recorded, at gradient 1:200, at the female 'on-site' installation.	419.
10/119	Basic solid velocity data, as recorded, at gradient 1:150, at the male 'on-site' installation.	420.
10/120	Estimated design velocity data, -- constructed from female 1:150 'waste load' data.	421.
10/121	Estimated design velocity data, - constructed from male 1:150 'waste load' data.	422.
10/122	Female facility design performance level.	423.
10/123	Male facility design performance level.	424.
10/124	Check of male facility design performance level.	425.

TERMINOLOGY, NOTATION AND ABBREVIATIONS.

- A = Flow Cross Sectional Area.
- A' = End of Solid Wetted Area.
- A'' = Wetted Area of Curved Sides of Solid.
- C1 = Empirically Determined Constant, (the theoretical solid velocity, on the 'zone 2' linear characteristic, coincidental with ' $\sqrt{L/G}$ ' equal to zero, - for a particular combination of solid and 'system geometry').
- C2 = Empirically Determined Constant, (the negative gradient of the 'zone 2' linear characteristic, - for a particular combination of solid and 'system geometry').
- C3 = Empirically Determined Constant, (the theoretical value of ' $\sqrt{L/G}$ ', on the 'zone 2' linear characteristic, coincidental with solid velocity equal to zero, - for a particular combination of solid and 'system geometry').
- C_f = Shear Coefficient.
- d_s = Thickness of Solid.
- F_B = Buoyancy Forces.
- F_C = Fluid Frictional Drag Force on Solid.
- F_F = Sliding Friction Force.
- F_{fw} = Fluid to Wall Friction Force.
- F_m = Negative of the Forces Acting on the Water.
- F_p = Hydrostatic Pressure Force on Solid.
- F_R = Reactive Force on Water (from the forces acting on the solid).
- F_s = Shear Force on Solid.
- F_{sw} = Solid to Wall Friction Force.
- G = Pipe Gradient.
- g = Acceleration Due to Gravity.
- h = Depth of Flow (Section 3.), or Pipe-Drop, as Appropriate.
- \bar{h} = Centroid Depth.
- K, K1 - K10 = Empirically Determined Constants.

- L = Pipe Length, (distance from input device).
- L_s = Length of Solid.
- m = Flow Hydraulic Mean Depth (Section 3.), Mean Number of Arrivals Per Interval, or Number of Cubicles, as Appropriate.
- m' = Mass Flow Rate Across Control Volume Boundaries.
- m_s = Mass of Solid.
- m_w = Mass of Water Within Control Volume.
- n = Number of System Users.
- P_f = Proportion of 'Loaded' Flushes Which Would be Expected to be 'Faecal'.
- P_{nf} = Proportion of 'Loaded' Flushes Which Would be Expected to be 'Non-Faecal'.
- $P(n)$ = The Probability That 'n' Users Arrive in any Given Interval.
- SD_p = Predicted Standard Deviation of 'Trailing Solid' Velocity.
- SD_f = Standard Deviation of 'Faecal Flush' 'Trailing Solid' Velocity.
- SD_{nf} = Standard Deviation of 'Non-Faecal Flush' 'Trailing Solid' Velocity.
- V = Water Velocity (Section 3.), or Solid Velocity (Elsewhere), as Appropriate.
- V_d = Estimated Design Level Solid Velocity.
- V_o = Solid Velocity at Entry to Pipe.
- V_s = Solid Velocity.
- w_s = Width of Solid.
- \bar{x}_p = Predicted Mean 'Trailing Solid' Velocity.
- \bar{x}_f = Mean 'Faecal Flush' 'Trailing Solid' Velocity.
- \bar{x}_{nf} = Mean 'Non-Faecal Flush' 'Trailing Solid' Velocity.
- z = Pipe Fall.

- α = Solid to Wall Sliding Friction Factor (Section 3.), or Mean Arrival Rate of W.C. Users (Elsewhere), as Appropriate.
- ϵ = Pipe Wall Roughness.
- ϵ_s = Surface Roughness of Solid.
- ρ = Fluid Density (Section 3.), or Traffic Density (Elsewhere), as Appropriate.
- ρ_s = Solid Density.
- μ = Fluid Viscosity.
- σ = Mean Service Rate.
- ϕ = A Function of.

SUFFIX

- u, d Conditions Upstream and Downstream of the Solid Respectively.
- l, s Relating to the Liquid or the Solid Respectively.

ABBREVIATIONS

- A.S.P.M. Association of Sanitary Protection Manufacturers.
- B.R.E. Building Research Establishment.
- C.B.C.S.M. Council of British Ceramic Sanitaryware Manufacturers.
- C.I. Cast Iron.
- D.H.S.S. Department of Health.
- D.V.M. Digital Voltmeter.
- F.A.S. Flush Ahead of Solid.
- G.L.C. Greater London Council.
- I.D. Internal Diameter.
- M/M/s A Queueing Theory.
- O.D. Outside Diameter.
- O.T.T.L.E. Optically Triggered Time Logging Equipment.

P.V.A. Polyvinylalcohol.

U.P.V.C. Unplasticised Polyvinylchloride.

W.C. Water Closet.

D.Re.G. Drainage Research Group, Brunel University.

N.B.S. National Bureau of Standards, Washington D.C..

1. INTRODUCTION.

1. INTRODUCTION

The successful operation of a building drainage system inherently implies that both fluid and solid waste is carried away from the building, into some collection network or system, with no hazard to the building occupants and with the minimum of maintenance expenditure. The first requirement, namely the avoidance of any possible health hazard, has, for many years, been seen as the criterion for designs which effectively ensure appliance trap seal retention, loss of trap seal integrity, through pressure fluctuations, being partly dependent upon system flow rates. Such design considerations tend to lead to a conservative approach to pipe sizing, where increases in pipe diameter can efficiently remove any pressure fluctuation problems. Paradoxically, such increases in pipe diameter may well effect system failure in respect of the second design criterion, namely the achievement of a minimal maintenance requirement, since resulting reductions in flow depth increase the probability of solid deposition. The introduction of water conservation as a further design criterion in recent years has naturally exacerbated this situation.

Drainage system solid transport, as such, received little attention prior to about 1970, since the main efforts of both designers and researchers were previously directed toward problems of trap seal retention. However, this situation has radically changed over the past decade, with the majority of the European and U.S. building research institutes now taking an active part in studies of solid transport performance.

The work reported in this thesis forms a central part of an integrated research programme undertaken at Brunel University by the Drainage Research Group (D.Re.G), of the Department of Building Technology, that has considered the mechanisms of solid transport through laboratory simulation, analytical representations of the system unsteady flow conditions, and through extensive site observations of installed system usage and operation. This programme, initiated by the U.K. Department of Health (D.H.S.S.), but also contributed to by a wide range of sponsors, recognised the need to provide numerical, quantitative data on system

performance, and hence involved the development of a range of instrumentation systems to measure, for the first time, building drainage system solid transport velocities.

In addition, and in respect of both 'live' and 'sterile' systems, the programme set out to relate the performance of solids in transit to solid geometry, pipework and input device parameters. It was intended that correlation between laboratory and installed systems would allow future design or code decisions to be fully checked, by laboratory tests, through the utilisation of approved solid simulants. This approach provided the basis for the work reported in this thesis. However, in view of the recent development of analytical methods to model drainage system flow and solid transport conditions, the work presented has now a wider significance.

The thesis presents the development of the approach to a solid transport based system design method, together with both details of the development of suitable instrumentation systems (to allow 'on-site' monitoring), and an assessment of design criteria based upon recorded system usage data.

2. PREVIOUS RESEARCH.

2. PREVIOUS RESEARCH

2.1 The Importance of Research to the Development of Drainage Design over the Last Fifty Years.

The historical evolution of water borne waste removal systems has been adequately detailed by many authors, such as Wise (1979), while also being the subject of review chapters in other theses (reported through the Drainage Research Group at Brunel), by such as Wakelin (1978) and Uujamhan (1981). In consequence, this review confines itself to a study of the importance of research to design method development, and attempts to both highlight those areas of uncertainty that remain, in respect of the guidelines for above ground drainage system design, and indicate how current research can aid in the resolution of such problem areas.

Since water borne waste removal systems have been commonplace in buildings for very many years, it might therefore appear that the scope for further fundamental research is limited. However, it may be shown that above ground drainage system design relies on a body of research work, of a fundamental nature, that can be traced over the last fifty years. From study of both this past research, and the then current design needs, it may also be seen, that the research results did materially change the designer's conception of the mechanism of operation of drainage systems, and led to both an economy of design and a marked reduction in the visual intrusion of drainage systems. A study of the purpose and objectives, of the research in this area currently underway, would show that the link between research objectives and the designer's needs is still strong. That this should be the case is of the utmost importance if design methods are to adapt to the new constraints, such as water conservation, now being applied.

The general introduction of recognisable drainage systems can be dated from the early 19th Century, although the precautions now standard, such as trap seal provision and venting, were not introduced for a considerable period. By the end of the 19th Century, the importance of trap seal retention, to the prevention of odour ingress and the maintenance of hygienic living conditions, had been appreciated. Standards were introduced, the effects of which can still be seen in current regulations and codes.

The general position, by the 1920's, was that large buildings were provided with a complex drainage pipe network, where waste from W.C.s was segregated from waste water from sinks, basins and baths. Each section was provided with its own stack, and each of these was paralleled by a separate 'vent stack', with vent pipes leading to each appliance. This 'two pipe system' therefore effectively featured four vertical stacks (two vent and two waste-carrying). Such a system, for a building of any height, resulted in a complicated network of piping, normally mounted external to the building, which could hardly be described as elegant. The complexity of the piping system naturally militated against internal mounting, and, as the U.K. climatic conditions did not enforce internal systems, this design situation continued for a considerable length of time. It would only be correct to state, that this design accurately reflected both the designers' understanding of the mechanisms of drainage operation, and their concern to adequately protect habitable space from the unpleasant effects of trap seal loss.

Thus, the lack of pressure from climatic conditions, or from special problems arising with increased building height, may be used to explain the longevity of the 'two pipe system' in the U.K. However, in North America, both of these factors contributed to the early use of an internal vertical drainage system, which employed a single vertical waste carrying stack, plus a single vertical vent stack, both stacks connecting to all W.C.s and other appliances. The need to equip designers with a better understanding of the mechanism of operation of this 'one pipe system', particularly in respect of the relationship between stack flow rates and the pressures, generated in the system, that could result in trap seal oscillations, led to the early research work that may be found dating from the 1920 period. The flow capacity of vertical stacks was investigated by Hunter (1924), while Babbitt (1924) and Dawson and Kalinske (1937) also considered this problem. Hunter (1924) proposed the 25% full rate, for vertical stacks, as a safety factor to avoid the formation of slug flow in the stack. This type of flow can result in pressure oscillations, as the air and water vapour pockets, between each water slug, alternatively open and close.

Work during this period also concentrated on the sizing of the vent system, and on flow interactions at branch to stack connections (Hunter et al (1938), and Dawson and Kalinske (1939)). Although certain assumptions were made in these investigations, particularly concerning the attainment of terminal velocity flow in vertical stacks, it is interesting to note that, some twenty two years later, Wyly and Eaton (1961) largely confirmed the safety factors proposed for stack volume flow rates.

The advantages of the 'one pipe system' were appreciated in the U.K. in the 1930's, and the system was gradually introduced from that time. The generation of pressure gradients within the branch piping network, by the flow in the vertical stack, was therefore a basic problem to be solved before any development of the 'one pipe system' could be envisaged. Pressure gradient problems may be categorised as self and locally induced siphonage of trap seal (being dependent upon the discharge profile of the appliance itself, and upon that associated with each other appliance discharging to the common branch, respectively), and as back pressure and induced siphonage (caused by the generation of pressures in the vertical stack that, in comparison to atmospheric pressure, are either high or low respectively). In each case, oscillations are set up in the trap which allow seal water to be lost, with the eventual result, that odours and unhygienic air may pass from the drainage system into the habitable space.

Any advance from the 'one pipe system' required basic research into the mechanisms of flow prevailing in the system. A research programme at the U.K. Building Research Station, in the 1950's, set out to provide this improved understanding. As reported by Wise (1952), initial investigations were related to the 'one pipe system'. However, results were sufficiently encouraging to allow the extension of the research to the 'single stack system', where the separate vent stack is dispensed with. In this system, retention of trap seal water is ensured by careful design of branch connections, particularly in terms of length and gradient. The early research reported by Wise and Croft (1954) applied up to five storey building heights, but more recently the concept has been applied for buildings up to thirty storeys (Pink (1973)).

Generally then, it may be seen that the result of the research effort, aimed primarily at the understanding of pressure variations, has been a real reduction in both the complexity of pipe networks, and the visual intrusion of such systems. The simplification of systems also contributed to greater installation flexibility (within the building fabric).

The design of modern above ground drainage systems is therefore largely based upon research work conducted over the past fifty years. The link between design needs and research objectives continues, and two main themes may be identified at present, namely a concern over the lack of usage data (and consequently, system loading data), and a growing interest in the effect of water conservation proposals on appliance and system design. At present, both of these topics are actively being researched by most building research institutes in western countries.

Usage and system loading present a range of problems to the designer. The fixture unit method, being an attempt to synthesise appliance discharge rate data with reasonable design decisions on the intervals between usage and usage satisfaction levels, has been applied for many years. Hunter (1940) applied such a technique to water supply demand, and the current fixture unit method employs similar technique to determine likely drain load (Burberry and Griffiths (1962)). Despite general acceptance of these techniques, the information available in respect of usage patterns is negligible. Some such data was presented by Wise and Croft (1954), and Webster (1972) and Courtney (1976) have more recently shown that demand unit methods consistently overestimate water supply demand, while Courtney (1976) suggests that a similar analysis of drainage systems would yield similar results.

The level of provision of sanitary appliances cannot be divorced from estimation of drain loads, and a recent study by Davidson and Courtney (1976) has shown that, for the office areas considered, current regulatory requirements are generally somewhat excessive. The influence of water conservation proposals upon drain load estimation (and the associated oversizing of drainage piping suggested by Courtney (1976)), must also be considered. Reduced levels of water usage may not simply

be viewed as an appliance design problem, but must be considered in relation to complete system performance, or at least in relation to performance from the W.C. through to a vertical stack or main drain junction. Furtherance of such consideration inevitably suggests investigation of both wave attenuation within long drainage pipe runs, and the transport characteristics of waste solids in drainage pipework.

Burberry (1978) has presented an approach to the wave attenuation problem that could be combined, through suitable design computer programmes, with waste solid deposit criteria. However, it is likely that this will remain a difficult area for some time to come. With regard to the study of waste solid transport characteristics, this must involve the establishment of relationships linking waste solid type to pipeline properties (such as gradient, diameter, material etc.,) and to local flow conditions (as determined by flush volume, system through-flow or wave attenuation effects). It is in the area of solid transport characteristics that the published work of the Drainage Research Group at Brunel University has concentrated, this study being just one of a series of interrelated studies.

The concentration of research in this area, at Brunel University since 1974, was initiated in response to a request from the Department of Health and Social Security (D.H.S.S.), through their Study Group 9, for advice in respect of hospital related drainage problems. An increase in the scale of building, coupled with heavier usage demands (in terms of disposable products), had, in preceding years, resulted in some systems working at the limits of successful operation. Such was the case in many of the large hospital developments of the 1960's, where the introduction of deep core planning, minimum interfloor space and a reduction in the number of vertical stacks internal to the building, had resulted in the design of long, shallow gradient pipe runs, which piperuns each accepted discharges from a wide range of appliances. This movement, toward designs more prone to solid deposition problems, unfortunately coincided with a considerable increase in the use of drainage system disposable items in nursing care procedures, and the compound result had been an increase in system maintenance requirements.

Since the aim of an efficient internal building drainage design must be the overall removal of waste, both solid and liquid, by the provision of a health hazard free system, an increased maintenance requirement must be viewed in relation to this specification, as well as in relation to the obvious factors of economy and interruption to normal building usage. Frequent blockages necessitate frequent clearing, and such increased maintenance, particularly in a hospital environment, can only increase the possibility of bacteriological release.

The main difficulty, in setting up the study at Brunel in 1974, was the lack of any relevant previously published work. Wyly (1964) had previously considered the problem, but with much greater flush volumes, while Tsukagoshi and Matsuo (1975), who were active at the time, did not measure solid velocity. Webster and Lillywhite (1979) recently reported a short series of tests carried out in the early 1970's, but due to the lack of velocity recording instrumentation, or an appreciation of the importance of the solid geometry parameters, this work failed to identify the governing relationships of solid transportation. It was therefore decided to undertake a basic study of the motion of a solid in a laboratory pipe system capable of gradient adjustment, over a wide range, and incorporating typical bends and junctions.

The pilot study, conducted within the Department of Building Technology, aimed to identify and investigate the parameters influencing waste solid transport, and to assess and comment on the feasibility of an integrated design technique. The success of the pilot study, reported by Swaffield (1975), led to further co-operation between Brunel University and the D.H.S.S.. The main current of subsequent research was reported by Wakelin (1978), who formulated a fundamental relationship linking the transport performance of specific sterile 'model' solids to pipe gradient. The research programme reported in this thesis, initiated in the summer of 1977, was primarily intended to assess the feasibility of both the development of more representative 'model' solids, and the correlation of laboratory and installed drainage system solid transport measurements. In the final event, the main body of work, conducted in this investigation, was centred around long-term observation of solid transport performance in an installed hospital

drainage network, and may be seen as an activity central to the overall effort at Brunel. These related studies, by the Drainage Research Group (D.Re.G), have been reported over a number of years by Swaffield et al (1975, 1977, 1978, 1980, 1981), Wakelin (1978), Marriott (1979), Westaby (1979) and Uujamhan (1978, 1981). In Section 2.2, the most relevant of these works are summarised.

2.2. A Review of Research Relating Directly to Solid Transport Studies, Both Completed and in Progress.

In the U.K., interest in the problems of solid transport was probably initiated by the problems encountered in the operation of the long, shallow gradient building drainage systems installed in many of the large hospitals built in the 1960's. Additionally, the growing concern with water conservation gave added impetus to the study of this topic, which is now actively being pursued at a number of centres in the U.K., Europe and the U.S.A.

The earliest systematic work on solid transport may be traced to Wylie (1964), working at the National Bureau of Standards, Washington, while in the U.K., Webster and Lillywhite (1979) refer to work conducted in the early 1970's. However, this work, and the contribution of Tsukagoshi and Matsuo (1975), were not primarily concerned with solid transport performance, and, as such, did not introduce the experimental and instrumentation techniques necessary to monitor solid velocity variations along the pipe system. Arising from the hospital drainage problems mentioned, the U.K. Department of Health (D.H.S.S.) initiated a study, at Brunel University, in association with the Drainage Research Group (D.Re.G). As outlined in Section 2.1, the work of the D.Re.G. has been reported over a number of years, and the most relevant studies are summarised below.

2.2.1 A Pilot Study

The results of a series of tests, carried out on a simple W.C. and variable gradient test rig were reported by Swaffield (1975). The probability of stoppages occurring in the waste pipe was shown to be dependent upon pipe gradient, waste material shape and velocity at entry

to the pipeline. It was suggested that bend effects were describable, by a waste solid velocity reducing factor, and empirical relations for a 135° bend were proposed. A design method for above ground drainage systems, based upon waste solid velocity, was shown to be feasible.

2.2.2 The Mechanism of Waste Solid Transport.

Based on the pilot study, and financed by the D.H.S.S., an extensive investigation, of the transport of solids in hospital about ground drainage systems, was conducted by Wakelin (1978). Tests were based on the measurement of solid velocity in a discharge pipe of variable gradient, the solid being a maternity pad either with or without three paper towels.

It was suggested that the travel of solids, in straight discharge pipes, could be characterised by three zones, each definable according to the predominance of particular forces acting upon the solid. Solids were found to decelerate rapidly at entry to the discharge pipe, and this was attributed to impact forces resulting from negotiation of the entry bend and first 2-3 metres of discharge pipe. Following flush water was observed to then dam up behind each such retarded solid, causing it to accelerate up to a velocity of approximately 1m/s. at a distance of 3-5 metres from the W.C. This entry region, typified by rapid deceleration and subsequent acceleration, was termed 'zone 1'. The limit of 'zone 1' was suggested to be approximately defined by the parameter $\sqrt{L/G} = 15$, where 'L' is the distance from the W.C. in metres and 'G' is the pipe gradient.

A non-linear solid deceleration was observed throughout 'zone 2', and it was suggested, by means of both dimensional analysis and recorded data analysis, that this could be defined by the equation $V = C1 - C2 \sqrt{L/G}$, where 'V' is solid velocity and 'C1' and 'C2' are empirical constants. This non-linear 'zone 2' deceleration was attributed to an imbalance between the forces promoting solid travel (the resolved component of the solid and water weight, and the pressure force due to the difference in water depth across the solid), and the frictional resistance to motion (proportional to the square of solid

velocity). It was further ventured, that 'zone 2' terminated on achievement of dynamic equilibrium (of the three forces mentioned), this transition point being approximately defined by $\sqrt{L/G} = 25$ to 35 .

'Zone 3', which was observed to be characterised by velocities below approximately 0.15 m/s., was suggested to be governed by the rate of water leakage past the solid (since such leakage caused a gradual reduction in the head of water across the solid). It was concluded that, due to the low rate of such water leakage, 'zone 3' flow conditions could continue for a considerable pipe length, but that any minor obstruction, such as a pipe coupler, could cause disruption of the critical force balance, thereby resulting in premature solid deposition. The length of 'zone 3' travel was therefore considered to be unpredictable, and, due to the risk of solid deposition, it was recommended that drainage systems be designed so as to avoid 'zone 3' flow conditions. The end of 'zone 3' was defined by ' $\sqrt{L/G}$ ' values of 35 , 34 and 29 , for U.P.V.C., glass and cast iron pipe materials respectively (for a single maternity pad).

Wakelin (1978) continued to consider the effects of various bends and junctions upon solid transportation, and concluded that such effects could be defined by reference to a datum of the equivalent straight pipe 'zone 2' performance level. Rapid solid deceleration was observed immediately downstream of any bend or junction, followed by a period of velocity regain. It was asserted, that such regain completely restored solid velocity to that level which would have been achieved had no such bend or junction been traversed. The length of pipe, over which solid velocity deviated significantly from the equivalent straight pipe datum, was defined as ' L_p ' (metres). The value of ' L_p ' was suggested to be generally below 5 metres, and it was ventured that a pipe fitting (bend or junction), positioned at least ' L_p ' metres from the onset of 'zone 3' flow conditions, would allow complete velocity regain, thereby avoiding premature solid deposition, and allowing that the effect of the pipe fitting could be ignored for design purposes.

This work concluded with the presentation of a design method, based on the fundamental equation, for 'zone 2' deceleration, as previously outlined.

2.2.3 Steep Gradient Discharge Pipes.

Swaffield and Marriott (1977) considered the case of solid transport in steep gradient discharge pipes. The 'model' solid employed was again the maternity pad, and transportation was examined, through 100 m.m. diameter U.P.V.C. waste pipes, over a range of different gradients between 30° and 90° to the horizontal. It was observed that, on entry to the discharge pipe, solids skated or 'surfed' over preceding flush water, in extreme cases attaining a velocity high enough to overtake all such preceding flush water. In such cases, solids were deposited ahead of the water stream and then re-introduced to motion, on subsequent arrival of the water stream, through impact with the leading wave. It was concluded that, since steep gradient discharge pipes caused an increase in the amount of useful water (that behind the solid), solid travel lengths would consequently be greater than might normally be expected.

This study put paid to the common belief that, due to water velocity tending to greatly exceed solid velocity, solids could become stranded in negotiation of steep gradient discharge pipes. As outlined, the exact opposite situation was shown to occur, solid velocity tending to exceed water velocity.

2.2.4 Reduced Flush Volume.

Swaffield and Marriott (1978) continued to consider the effects, upon maternity pad 'model' solid transportation, of reduced flush volumes. It was observed that reduction in the volume of flush water lead directly to shorter solid travel distances (in 100 mm. diameter U.P.V.C discharge piping), but that, by the use of either smaller diameter piping (75 mm.), or 'parabolic section' piping (represented by Marley 'Deep Flow' guttering), considerably longer solid travel distances could be achieved.

Two empirical equations were formulated. The first, which was viewed as an extension to Wakelin's (1978) equation for 'zone 2' deceleration (see Section 2.2.2), linked solid velocity, 'V', to pipe gradient, 'G', and flush volume, 'F', (between 6 and 9 litres), and was of the form:-

$$V = \frac{(K1 - F)}{K2} - \frac{(K3 - F)}{K4} \cdot \sqrt{\frac{L}{G}}$$

where K1-K4 were empirically determined constants for each W.C. and pipe cross sectional configuration.

The second equation linked flush volume, 'F', (between 3-9 litres), to solid deposit position, 'Ld', gradient, 'G', and 'Lm', the solid travel length which was always achieved (provided the solid cleared the trap of the W.C. pan), and which was suggested to be dependent upon W.C. to waste pipe connection geometry, and independent of gradient. This equation was of the form :-

$$F = K5 + K6 \cdot \frac{(Ld - Lm)}{G}$$

where K5 and K6 were empirically determined constants.

An interesting footnote to this report was the suggestion of a direct link between the volume of water contained in the trap of the W.C. pan and the amount of water discharged ahead of the solid, it being ventured that, on average, these two volumes would equate. The study concluded on a cautionary note, through reference to Mendes (1977), pointing out the inversely proportional relationship, between bacterial activity (in the trap of the W.C. pan), and the volume of flush water, which would inevitably result were W.C. units not specifically designed to function with reduced flush volumes.

2.2.5 W.C. Discharge Geometry

The effects of W.C. discharge geometry, upon maternity pad 'model' solid transportation, were investigated by Uujamhan (1978). Observations were concentrated on the area of 'zone 1' flow conditions, as opposed to the area of 'zone 2' flow conditions previously considered fundamental, as postulated by Wakelin (1978), (see Section 2.2.2). It was suggested that solid motion, in a 100 mm. internal diameter U.P.V.C. discharge pipe, is dependent upon W.C. discharge geometry, and improved solid transport was demonstrated by turning the W.C. pan at right angles to the normal 'in-line' position.

It was proposed that 'zone 1', as previously defined in Section 2.2.2, should be separated into two distinct flow regimes, the first sub-zone being that of rapid deceleration, and the second being that of velocity regain. It was suggested that the rapid deceleration sub-zone could be defined by an equation of the form:-

$$V = \left(\frac{h + K7}{K8} \right) \cdot \left(\frac{1}{L} \right)^{\left(\frac{h+K9}{K10} \right)}$$

where 'V' is the solid velocity, 'L' is the distance travelled from discharge pipe entry, and K7-K10 are empirically derived constants. Generally, solid transportation was found to improve with increased 'pipe-drop', ('h').

2.2.6 Analytical Approach to Solid Transport.

In parallel to the Brunel research, over the 1977 to 1980 period, the Centre for Building Technology at the National Bureau of Standards, Washington D.C., under a H.U.D. contract concerned with water conservation, had been considering the problems of defining 'safe' waste solid transport distances and flow rates. Close links with the Brunel group resulted in communality of instrumentation, for solid velocity measurement, as reported by Galwin (1979).

The N.B.S. approach was to replace the deformable maternity pad solids, as used at Brunel, with a range of hollow plastic cylinders (which varied in length from 38 to 80 mm., and in diameter from 10 to 38 mm.). Specific gravity could be controlled by filling the cylinders with fluid. Fundamental work was undertaken on the force balance equations, that has resulted in the development of analytical expressions for body force and flow rates, as necessary for the initiation of solid transport for deposited solids, Galwin et al (1981).

As a result of this communality of interest and approach, a Joint N.B.S./ Brunel project, funded through the U.S. Department of Commerce, has

been underway at Brunel since 1981. This project is concerned with the application of the numerical method of characteristics, to the attenuation of wave profiles along drains, and to the prediction of solid transport based upon the force balance equations (as reported by Swaffield et al (1981)). The method of characteristics is a technique for solving simultaneous partial differential equations, of the form that govern unsteady flow in partially filled pipes, and, as such, can be applied, via a computer program, to predict wave attenuation. In addition, the finite difference scheme, central to the technique, allows the inclusion of moving boundary equations, such as the force balance defining solid motion in terms of the adjacent fluid conditions, and hence can be utilised to predict solid transport performance.

However, such an analytical approach cannot be taken in isolation from the observations of solid transport in installed systems. In that respect, the work reported in this thesis provides a bridge, between actuality and analytical prediction, that may, in the future, make it possible to delete the intermediate laboratory testing phase on which design decisions were initially intended to depend.

The analytical methods now being developed, jointly by N.B.S. and Brunel, are beyond the scope of this current thesis. However, it is stressed that, rather than reducing the importance of the work reported here, these new developments bestow an enhanced importance on the observations of solid transport in installed systems.

2.3. Conclusion

This brief review of the importance of research, in the development of drainage system design, highlighted the need to undertake a programme of installed system solid transport and usage pattern monitoring. The reported research was intended to fill this gap, and, in doing so, has provided a fundamental basis for future advances, in design methods, that will utilize analytical methods to solve flow conditions previously thought too complex.

3. IDENTIFICATION OF THE FORCES ACTING ON A SOLID IN TRANSPORT.

3. IDENTIFICATION OF THE FORCES ACTING ON A SOLID IN TRANSPORT.

In order to understand the mechanisms of solid transport, and perhaps more importantly, deposition, it is necessary to identify the forces that are involved in determining the solid's motion. Garg and Round (1969-70) analysed the forces acting on an isolated capsule travelling freely within a pipeline with both oil and water full bore pipe flow. Although the flow conditions in that work were steady and uniform, results support the present treatment of forces acting on individual solids in the unsteady, non-uniform open channel flow conditions characterizing drainage systems.

A basic illustration of the forces determining solid motion through a drainage system is presented in Figure 3/1. This general statement of the problem applies to a wide range of situations. Referring to Figure 3/1, the hydrostatic head difference across the solid will generally produce a thrust on the solid in the flow direction, as will the component of the solid's weight force along the pipe slope. Water leakage over and around the solid will also produce a force in the flow direction due to the shear stress produced at the solid surface where the fluid velocity tends to zero (i.e. the condition of 'no slip' between a solid and a covering flow). If, for some reason, a solid should move at a greater velocity than surrounding water streams, then it will be subjected to a fluid frictional drag force in place of the positive shear forces.

However, assuming solid velocity to be less than that of the surrounding water surface, fluid frictional drag forces will still be applied, in the fluid annulus beneath the solid, in addition to positive shear forces. Under laminar conditions, flow in the annulus between pipewall and underside of solid could be described as Couette flow, where a surface, drawn through a stationary fluid, produces a parallel fluid flow. Velocity profiles, associated with such entrained flows, are often predictable. Although, in their work on this phenomenon in the fluid annulus around their capsule, Garg and Round (1969-70) were able to refer to a considerable body of data on laminar flow under these geometric constraints, no such data exists for open channel flow, let

alone for an annulus formed between a pipe wall and a deformable surface under transient open channel flow conditions.

Thus, hydrostatic pressure, a component of weight and positive shear forces all serve to promote solid travel, while frictional drag and fluid to wall friction forces serve to inhibit such travel.

3.1 Development of Empirical Relationships Governing Waste Solid Transport in Drainage Systems.

To provide a basis for an experimental treatment of waste transport, Swaffield (1980) carried out a dimensional analysis involving the wide range of variables thought to be relevant. Without such a rationalisation, experimental work would have lacked direction, and central relationships could have been overlooked.

It was considered that the local solid velocity, ' V_s ', at some point, 'L', along the waste pipe, could be expressed as:-

$$V_s = \phi_1(\rho, \mu, \epsilon, m, L_s, d_s, w_s, \rho_s, \xi_s, L, z, g, V_o) \quad (1)$$

where the variables chosen describe the pipe material, flow conditions, fluid used, size and type of solid and the pipe slope.

Thus fourteen variables were taken to describe the solid's motion, yielding, on analysis, eleven dimensionless groups:

$$\frac{V_s}{\sqrt{mg}} = \phi_2 \left(\frac{\rho V_s m}{\mu}, \frac{V_o}{\sqrt{mg}}, \frac{\epsilon}{m}, \frac{d_s}{m}, \frac{L_s}{d_s}, \frac{w_s}{d_s}, \frac{\xi_s}{\epsilon}, \frac{L}{m}, \frac{\rho_s}{\rho}, \frac{z}{L} \right) \quad (2)$$

Many of these groupings have recognisable forms, e.g.:-

$\frac{V_s}{\sqrt{mg}}$ and $\frac{V_o}{\sqrt{mg}}$ represent a form of Froude No. based on solid velocity

at some point 'L' along the pipe, and at pipe entry $\frac{\rho V_s m}{\mu}$ has the

form of Reynolds No.

ξ/m is the pipe wall relative roughness in terms of the open channel hydraulic mean depth, and may be used as a pipe material characteristic.

$\frac{d_s}{m}$, $\frac{L_s}{d_s}$, $\frac{w_s}{d_s}$ and $\frac{\xi_s}{\xi}$ define the size of the waste solid and its surface

roughness. ρ_s/ρ is a mass ratio term. z/L is the pipe gradient, while the m/L term is a measure of the solid pipe blockage effect, as it relates hydraulic mean depth behind the solid to distance travelled along the waste pipe.

Careful formulation of test conditions could reduce this spread of variables and allow comparable tests to be carried out, e.g.:

$\frac{\xi_s}{\xi}$ could be held constant if one pipe material was employed.

$\frac{d_s}{m}$, $\frac{w_s}{d_s}$, $\frac{L_s}{d_s}$, $\frac{\xi_s}{\xi}$, $\frac{\rho_s}{\rho}$ could be held reasonably constant by use of a standard

solid, allowing the effect of pipe gradient, wall roughness, flush volume etc. to be studied. $\frac{\rho_s V_s m}{\mu}$, representing the flow Reynolds No.,

may be ignored on the basis that open channel flow conditions are not sensitive to variations in this parameter.

Thus, for tests with one waste solid type in one waste pipe, Swaffield (1980) reduced the equation to:-

$$\frac{V_s}{\sqrt{mg}} = \phi_3 \left(\frac{V_o}{\sqrt{mg}}, \frac{m}{L}, G \right) \quad (3)$$

where pipe gradient $G = z/L$.

As deformable solids tend to be discharged from the W.C. in a fairly random manner as far as shape is concerned, the solid's geometry terms are strictly not held constant, and this would be expected to result in a spread of results in any data presentation based on equation (3).

The hydraulic mean depth in the flow adjacent to the solid would be difficult to record and thus equation (3) may be modified by the acceptable multiplication of dimensionless groups to yield:-

$$\frac{V_s}{\sqrt{Lg}} = \phi_r \left(\frac{V_o}{\sqrt{Lg}}, \frac{m}{L}, G \right) \quad (4)$$

Since observations have shown that depth of flow behind a solid remains fairly constant (for the fundamental 'zone 2' flow regime discussed in Section 2.2.2), Swaffield (1980) suggested that any experimental results for 'zone 2' would not be sensitive to changes in the m/L group. Thus, for 'zone 2' only, the equation (4) was reduced to:-

$$\frac{V_s}{\sqrt{Lg}} = \phi_s \left(\frac{V_o}{\sqrt{Lg}}, G \right) \quad (5)$$

Consideration of open channel flow relationships suggested that the square root of the pipe gradient was the determining factor, thus:-

$$\frac{V_s}{\sqrt{Lg}} = \phi_G \left(\frac{V_o}{\sqrt{Lg}}, \sqrt{G} \right) \quad (6)$$

Since the length of pipework required, 'L', for a given velocity change, $(V_o - V_s)$, would be expected to increase as gradient, 'G', became steeper, and hence numerically larger, it was postulated that, for 'zone 2' only, a relationship could be expected of the form:-

$$\Delta V = V_o - V_s \propto \sqrt{\frac{L}{G}} \quad (7)$$

Swaffield (1980) concluded by suggesting that this form of relationship should be employed as a means of data presentation for each test condition.

3.2 Analytical Approaches to the Solution of the Forces Acting on a Solid.

Swaffield (1980) attempted an analytical solution of the forces acting on a solid (being transported through a drainage system), through consideration of a control volume, ABCD, and the forces acting both on the solid and on the fluid annulus, within ABCD, see Figure 3/2. The momentum equation was applied to the fluid flow through the control volume, and Newton's 2nd Law was applied to the solid. Substitution into the momentum equation of the solid reactive force on the water (gained through Newton's 2nd Law), yielded:-

Net force on water in ABCD = Rate of change of momentum across ABCD

$$\rho \cdot g \cdot \bar{h}_u \cdot A_u - \rho \cdot g \cdot \bar{h}_d \cdot A_d + m_w \cdot g \cdot \sin \theta - F_{fw} - F_R$$

$$= m'_d \cdot (V_d - V_s) - m'_u \cdot (V_u - V_s) \quad (8)$$

Force = Mass x Acceleration

$$F_R + m_s \cdot g \cdot \sin \theta - F_{sw} = \frac{m_s \cdot dV_s}{dt}$$

$$\therefore F_R = \frac{m_s \cdot dV_s}{dt} - m_s \cdot g \cdot \sin \theta + F_{sw} \quad (9)$$

Substitution

$$\rho \cdot g \cdot \bar{h}_u \cdot A_u - \rho \cdot g \cdot \bar{h}_d \cdot A_d + m_w \cdot g \cdot \sin \theta - F_{fw} + m_s \cdot g \cdot \sin \theta$$

$$- F_{sw} - m'_d \cdot (V_d - V_s) + m'_u \cdot (V_u - V_s) = \frac{m_s \cdot dV_s}{dt} \quad (10)$$

This model includes all of the forces acting on the solid, the shear forces being represented within the reaction force, 'F_R'. However, the model has a drawback in the presence of the water mass term, 'm_w', which

depends upon the choice of control volume and upon the wall to fluid frictional force which effectively replaces the body shear force.

While this model remains to be investigated further, an alternative approach, that has been utilised, is based upon the solid itself as the limits of the control volume. In this alternative approach, Figure 3/3, the force equation is applied directly to the solid as follows:-

$$\begin{aligned} & \rho \cdot g \cdot \bar{h}_u \cdot A'_u - \rho \cdot g \cdot \bar{h}_d \cdot A'_d + (m_s \cdot g - F_B) \cdot \sin \theta - \alpha (m_s \cdot g - F_B) \cdot \cos \theta \\ & = m_s \cdot \frac{dV_s}{dt} \end{aligned} \quad (11).$$

Two points need to be made concerning this expression. Firstly, the shear force arising from flow over solid is neglected. This force would have the form:-

$$F_{\text{shear}} = C_f \cdot \frac{1}{2} \cdot \rho \cdot |V_u - V_s| \cdot (V_u - V_s) \cdot A'' \quad (12).$$

where C_f is a drag or shear coefficient, and A'' is the wetted area of the curved sides of the solid (assuming a cylindrical 'model' solid). If the water velocity approaches solid velocity, ' $V_u \rightarrow V_s$ ', then the shear is negligible, and this may be taken as justification for dropping this term for floating solids. Alternatively, if ' $V_s > V_u$ '/' $V_s < V_u$ ', then the shear force becomes a 'retarding'/'propulsive' force.

The second area of discussion, relating to this expression, has to do with the direction of the buoyancy force ' F_B ' which is simply calculated by reference to the volume of water displaced by submerged portions of the solid. In expression (11), the buoyancy force is considered vertical, but it may be argued that buoyancy force represents the resulting pressure force on the submerged solid surfaces, and hence should be perpendicular to the pipe wall. This change would affect the down slope mass force and the friction force. This unresolved discussion has roots in the work published by Francis (1956), and it is difficult to resolve as the likely differences in 'model' solid speeds are within the variations of local velocity in the open channel velocity profile.

This discussion of the forces acting on a solid has been included as an aid to later discussion of the observed solid velocities, rather than as a definitive statement of the force equations. Parallel work currently in progress, Swaffield, Galwin et al (1982), deals in more detail with the analytical models that derive from these equations. However, it must be stressed that these numerical approaches will require reference to observations of 'live' waste load transport, as presented in this thesis, and hence, this work may be seen as an integral part of current research efforts.

4. APPARATUS AND INSTRUMENTATION - DEVELOPMENT FOR THE LABORATORY.

4. APPARATUS AND INSTRUMENTATION - DEVELOPMENT FOR THE LABORATORY.

It was considered appropriate to adopt basic apparatus and instrumentation as employed by Wakelin (1978), but with certain modifications, at least as regards the projected laboratory based experiment, as this study was intended as a continuation of that work.

4.1 The Water Closet (W.C.) and Support Rig.

Two W.C. pans were employed during laboratory experiments, both of which were P-trap. The decision to restrict the input device to P-trap pans was based on the results of enquiries, concerning the market penetration of various W.C. types in the U.K., carried out by the Council of British Ceramic Sanitaryware Manufacturers, (C.B.C.S.M.). A Twyford's P-trap W.C. pan, built to comply with B.S.1213 and having a 109° outlet, was utilised for the experiments performed using a variety of sanitary protection products as model solids, see Figure 4/1. This pan was considered appropriate as the previously mentioned C.B.C.S.M. survey suggested it to be widely used. An Armitage Shanks V1206 Contour P-trap pan, conforming to B.S.3402 and illustrated in Figure 4/2, was used for all remaining laboratory experiments. The V1206 pan, being a Ministry of Health selected design, was considered appropriate for this hospital based study.

The support rig for the W.C. pan, as shown in Figure 4/3, was constructed from Dexion angle, and consisted basically of a 2 m. x 2 m. platform mounted 2 m. above floor level. The selected W.C. pan and variable height flushing cistern were mounted upon this platform, which was designed to safely support loads of up to 1,000 Kg.

4.2 Pipes and Fittings.

Marley transparent U.P.V.C. (unplasticised polyvinylchloride) pipework, specially manufactured for research purposes, was used throughout this study.

This pipework conformed to the same specifications and tolerances as the normal opaque Marley U.P.V.C. pipe. Seven standard 2 m. lengths of 100 mm. internal diameter (I.D.), 110 mm. outside diameter (O.D.), were connected employing normal opaque U.P.V.C. ring seal couplers. Care was taken to ensure that good joints were constructed, pipe ends being bevelled neatly to prevent any unnecessary obstruction to solid transport, and silicone lubricant being applied to ensure good seal and to facilitate easier connection.

Connection to the W.C. pan was achieved with a plastic Terrain adaptor No. 125.4.5. fitted with a Terrain No. 9124 rubber W.C. connector. This was close coupled to a 104° Key Terrain Junction using a short length of 100 mm. I.D. transparent Marley pipe. A short vertical length of the same Marley pipe was then fitted to the bottom of the Junction, and a 92½° bend joined in turn to the bottom of this pipe and then fitted to the horizontal pipe. The length of this vertical pipe was cut to provide the standard 300 mm. from the platform level of the W.C. support rig to the centre line of the horizontal discharge pipe, as recommended by the Department of Environment. The top of the 104° Junction was fitted with a 100 mm. x 50 mm. reducer. The outlet end of the discharge pipe was fitted with a 92½° Junction, with short lengths of pipe fitted above and below, to simulate a vertical stack connection. Figures 4/4 and 4/5 show the arrangements, at the inlet and outlet ends respectively, of the discharge pipe. Figure 4/6 illustrates the cistern/W.C. configuration.

4.3 Discharge Pipe Support Rig.

To ensure rigidity and linearity of the discharge pipe, two off 7.3 m. heavy duty light weight aluminium ladders were employed. The ladders were fixed end to end by Dexion Angle, and suspended, with rungs in a vertical position, from turn buckles which provided a simple method of height adjustment. This achieved a high modulus of rigidity with minimum weight. The turn buckles were themselves hung from simple Dexion frames, which were supported on the floor and clamped to the laboratory roof truss'. Figure 4/7 illustrates this arrangement.

The discharge pipe was supported beneath the ladders utilising the normal Marley system of JB42 two piece brackets and SC621 barrel clip collars. Each bracket was fixed to a length of 8 mm. (5/16") studding which was passed through a hollow rung of the ladder at the appropriate support interval. Each length of studding was then firmly fixed in position by tightening nuts and washers above and below the ladder. There was a certain amount of deflection of the ladder under both its own weight and the applied load, but this was nullified by precise levelling of the discharge pipe.

After attaching the discharge pipe beneath the ladder support, and having adjusted the ladder to be approximately horizontal, the centre line of the inlet end to the discharge pipe was adjusted to be the standard 300 mm. below the platform level of the W.C. support rig. A surveyor's level was then set up with its height of collimation at the same level as the top external surface of the inlet end of the discharge pipe. This enabled the discharge pipe then to be levelled to horizontal, without the need of a levelling staff, the studding supports being adjusted as necessary to achieve this. It then became possible to set any desired gradient, simply by adjusting the turn buckles to the appropriate height.

4.4 Flushing Mechanism

An automated method of flushing was adopted, as devised by Wakelin (1978), and shown in Figure 4/8, in order to overcome the variable human element involved in flushing the cistern. The ram of a two way compressed air operated electrically actuated solenoid valve, controlled by a push button on the instrumentation table, was connected to the cistern lever. Not only did this method provide a standard and repeatable force on the flush handle, but also allowed for centralised control of the rig.

4.5 Measurement of Flush Ahead of Solid.

It was considered appropriate to measure the amount of water discharged ahead of any solid evacuated by the W.C. into the discharge pipework. Unfortunately, no method of doing this could be devised which would not have interfered with the solid transport. It was therefore decided, as the best obtainable approximation to the required information, to measure the proportion of flush ahead of the solid at discharge from the monitored length of pipework. There were limitations to this method in that, in all cases, the measurement included the amount of water which bypassed the solid during its passage through the pipework. Such measurement was, however, considered useful when monitoring solids which did not allow significant bypass of flush water. On the total flush being discharged from the pipework prior to a solid, the solid having been deposited, the approximation became invalid. However in practice it was found that the volume flow rate was greatly decreased for water which bypassed a stoppage as compared to water which preceded it. This allowed the volume of water ahead of the solid at the moment of stoppage to be estimated, as the change in volume flow rate could be detected by the L.V.D.T., (described later in this section). This estimate was then used as the best obtainable approximation to the required information. The method of measuring the percentage flush ahead of solid, as devised by Wakelin (1978), is outlined below:

The discharge from the W.C. via the waste pipe was collected in a 227 litre drum referred to as the discharge collection tank, see Figure 4/5. Water was pumped to a convenient drain from the tank through a flexible hose from the tank bottom. The inlet to the hose was protected from solid blockage by means of a net in the collection tank, which also served to sieve solids from the water. The pump discharge outlet pipe was raised above the tank water level to prevent water discharge by siphonage. A linear voltage displacement transducer (L.V.D.T.), operated by a float attached to a vertically mounted displacement rod, was positioned in the discharge collection tank.

The L.V.D.T. produced a linear voltage output, within its linear range of ± 0.05 m., with respect to water level variation. The output from the L.V.D.T. was fed to one channel of a pen recorder, and the discharge from the cistern into the collection tank was calibrated against a full scale deflection of the pen recorder channel. It then became possible to calculate the amount of water entering the tank ahead of the solid, as the solid entry into the tank caused a sudden jump on the pen recorder trace.

A Waverly liquid level control, having sensors at high and low level, was also incorporated into the discharge collection tank. This allowed the water level to be pumped down to a consistent datum prior to each flush, coinciding with the lower sensor, and thereby re-setting the L.V.D.T float to its start position. On the water level inadvertently being allowed to rise to a high level, and in order to avoid spillage, the upper sensor was utilised to automatically operate the pump. This being the case the lower sensor would terminate pumping.

4.6 Measurement of Solid Velocity.

The measurement of solid velocity was achieved by the use of photoelectric cells (MRD40 phototransistors). On having a small voltage applied across it, a phototransistor generates a minute current which will increase and modulate according to the light intensity falling upon it. By shunting the photo cell output to earth using a suitable resistance, a modulating voltage can be derived in place of the modulating current. If a beam of light falling upon a photo cell is interrupted the output voltage drops, and this change can be noted using a pen recorder. This was the principle used in the method of solid velocity measurement developed by Swaffield (1975). Photoelectric cells were mounted at 3.71 metre intervals along the monitored pipework, each photo cell being diametrically opposite to a light source, see Figure 4/9. The photo cells were linked to a pen recorder via a control box. As the leading edge of the water component of the flush passed each light source, so the output from the corresponding photo cell was decreased, this change in output being displayed on the pen recorder by a change in pen deflection.

As the leading edge of the solid passed each light source, so the photo cell voltage output dropped by another step increment, giving a more pronounced and readily identifiable pen deflection. By analysing the traces on the pen recorder, knowing both the pen recorder paper speed and the separation of the photo cell sensors along the pipe, it was possible to calculate mean water and solid velocities.

Wakelin (1978) found this method to be unacceptably inaccurate when attempting to measure 'point velocities', using a sensor separation as small as 100 mm., as opposed to mean velocities over 3.71 m. as used by Swaffield (1975). Wakelin (1978) therefore devised a system based on six O.M.B. Electronics type 745 timer counters. Each timer was associated with a pair of photo cell / light source units placed at a known, but small, distance apart. The principle of this method was that the negative going voltage pulse produced by the first photo cell of a pair, on a solid passing between its light source and sensor, initiated 'timing start' of the associated timer. A similar output from the second photo cell of a pair initiated 'timing stop'. The two pulses were fed to an electronic signal conditioning circuit which used them to produce the necessary signals to start and stop the timer. This was necessary as the voltage pulses from the photo cells were not directly compatible with the timer. Wakelin (1978) then placed six pairs of photo cells at intervals along the monitored pipework, and measured 'point velocities', as opposed to mean velocities over large distances.

On attempting to reconstruct the system adopted by Wakelin (1978), it was noted that, due to a simple time constant imposed by the circuitry associated with the phototransistor, the leading and trailing edges of the pulses displayed exponential form. Also, the amplitude and voltage range of the pulses varied significantly with ambient light intensity. For this reason, the output pulses from a typical phototransistor could not be expected to display exactly similar characteristics for the complete duration of an experimental programme.

For optimum triggering of the timer, the pulses, from which the start and stop signals were derived, should have had repeatable high and low magnitudes and voltage swing. It was not considered necessary to hold duration constant. Because the low value of the input pulses was not constant, the pulses were fed through comparitors with reference voltage (timer triggering level), being the lowest voltage which was always observed to fall well within the range of the pulse.

Due to the exponential form of the leading edge of the pulses, the comparitors changed over (triggered the timers), at a point not easily distinguished, and as the pulse amplitude varied, so the time of changeover varied considerably, see Figure 4/10. To successfully operate the solid velocity measuring instrumentation in this form, triggering of timers being initiated by the leading edges of the pulses, it would have been necessary to extend the calibration of relevant voltage levels to almost a continuous process, triggering levels being constantly monitored. Several attempts were made to overcome this problem, without interference to the basic design of instrumentation, and they are briefly outlined below:

The voltage level at which the timer triggered could have been increased, thus moving to a position on the leading edge of the pulse where a small change in pulse amplitude would not significantly affect the moment in time of timer triggering. However, at this position pulses from water interference fell below the changeover level, and either initiated or stopped timing. On introduction of a time constant the high frequency water pulses were eliminated, but adversely, this considerably lengthened the rise time of the solid pulse, and change in amplitude again had an effect on the moment of triggering.

A similar approach was to black out the area of pipework immediately adjacent to each photo cell, thus attempting to eliminate access of ambient light, being the root cause of pulse amplitude variation. This proved insufficient, complete blackout of the entire length of pipework being required to produce any significant result. Such action would have defeated the object of employing transparent pipework to observe, as well as monitor, the action of solid transport.

If the voltage output from the phototransistors could have been greatly increased, then small fluctuations due to ambient light variations would have been insignificant as a proportion of the whole. This proposition seemed feasible provided that light intensities remained below the saturation level of the phototransistors. However, the magnitude of light source, required to produce any significant voltage increase, proved to be impractical and unacceptable. A system was then constructed, which employed lenses to direct and intensify the light output to the photo cells. This successfully increased voltage output from the phototransistors, but unfortunately, reflection and refraction during system operation then became a source of unacceptable variation in voltage output.

As previously stated, due to the exponential form of the leading edges of the pulses received from the phototransistors, the comparitors triggered timers at a point not easily distinguished, and as the pulse amplitude varied, so the moment of triggering varied unacceptably. Under the same circumstances, the changeover point on the trailing edge did not vary significantly, see Figure 4/10. It was decided that the 'timing start' and 'timing stop' signals should therefore be derived from the trailing edges of the input pulses. A new pulse comparator control console had to be constructed, switching on the trailing edges of input pulses, incorporating a facility comparing the number of pulses counted by the 'timing start' and 'timing stop' photo cells associated with each timer, a visual alarm (Light Emitting Diode, or L.E.D.) being triggered if the two did not match. This was to ensure that, if a high frequency pulse, caused by water interference, should trigger a timer by mistake, the operator would be aware of the fact. The new console, known as the Optically Triggered Time Logging Equipment (O.T.T.L.E.), also enabled the operator to display triggering levels, on a digital voltmeter (D.V.M.), and adjust them as necessary. The facility to display phototransistor voltage outputs on the D.V.M., which had been incorporated into Wakelin's (1978) monitoring instrumentation, was retained. The circuit and timing diagrams for O.T.T.L.E. are presented in Figures 4/11 and 4/12 respectively. Figure 4/13 illustrates the completed console, and Figure 4/14 shows the 'central control' instrumentation table.

4.7 Experimental Method.

Since this study was intended to investigate the relationships between various solid parameters and resulting solid transport, as opposed to between various details of pipework geometry and resulting solid transport, once having been set up, the test rig was preserved, throughout, without alteration.

The gradient was set to 1:80 as described in section 4.3. The cistern was set to discharge 9.1 litres, and periodically checked, simply by repeatedly collecting the discharge in a measuring cylinder and adjusting the position of the cistern float until the correct discharge was obtained. The L.V.D.T. pen recorder displacement was then adjusted to give a full scale deflection of 8 squares or 40 mm.. This was achieved by adjusting the voltage range, the zero and gain controls, of the pen recorder. The range of the L.V.D.T. for which it gave linear response was used throughout the experiments. The photo cells and associated light sources were placed along the pipework in pairs, each pair being 'timing start' and 'timing stop' photo cells having 300 mm. separation between the two. Six pairs of photo cells were located along the discharge pipe, the pairs being centred on 3.049 m., 5.081 m., 7.113 m., 9.146 m., 11.178 m., and 13.211 m., as measured from the W.C.. Calibration of timers was considered unnecessary, due to the improved method of initiating timer triggering, although individual timers were compared periodically to guard against malfunction. The timer triggering levels were adjusted to suit each solid type under test, it being considered desirable, for maximum protection against error, that triggering levels be at the lowest voltage to always be greater than the lowest voltage of a 'negative going' pulse, as the magnitude, of the pulse initiated, depended upon various parameters of the solid.

4.8 Data Handling and Presentation of Results.

For each experiment, or series of tests, full details of the test rig configuration and the solid parameters were recorded, notably; pipe gradient, W.C. type, solid material and geometry, method of introducing the solid into the pan.

The number of velocity points, the distance of each velocity point from the W.C., the separation of photo cells at each velocity point, and the deflection of the L.V.D.T. representing 9.1 litres, all being data which remained constant for any one set up of the test rig, were also recorded. Data which changed with each successive run were then noted run by run, namely; run number, stoppage position if relevant, deflection of L.V.D.T. for flush ahead of solid, and the timer counter readings for each velocity measuring point.

If a solid stopped in the discharge pipe, solid velocities, at all points downstream of the stoppage, were recorded as zero. Any such zero velocities were considered acceptable data in calculating statistical figures.* On the occurrence of a stoppage, a second flush was operated to clear the pipework, and no data were recorded for such a clearance run. If any malfunction of the monitoring equipment were detected, the complete flush was rejected, no data being recorded for that run. On a solid failing to clear the trap of the W.C., no other data were recorded, the run being designated as a 'W.C. failure'. Although statistical analysis of solid stoppage position was undertaken, it was accepted, that such figures were only truly valid if all of the solids monitored, in any particular test, were deposited within the available length of monitored pipework.

All recorded data was punched onto paper tape using a Teletype (type 2742A) punch. Simultaneous with punching the paper tape the teletype produced a readable translation, therefore facilitating easy checking of the punched data against recorded data. Paper tape was chosen as the data input medium since paper tape does not deteriorate with time, whereas computer cards do have this tendency. The previously outlined input data was processed by the computer program 'MASTER DREG'. This program, full details of which are presented in Appendix.I, was written in Fortran and run on the Brunel University ICL 1903 computer.

* This technique has been standard practice throughout the most relevant previous research, for instance; Swaffield (1975), Wakelin (1978).

5. FAECES, AND SUBSTITUTE 'MODEL' SOLIDS.

5. FAECES, AND SUBSTITUTE 'MODEL' SOLIDS.

The lack of a sound basis for the choice of a 'model', in the simulation of 'live' faecal waste, can be identified as one of the main problems to have delayed progress in this area of drainage research. In view of the scale of testing envisaged for this study, and having full regard to the avoidance of any possible health hazard, the problems inherent in the use of faecal material (in an open laboratory environment), concerning procurement (possible use of hospital bed-pan wastes), transportation, handling, storage, usage in experiments and eventual disposal, were found to be insoluble, and therefore the overwhelming difficulties involved in the development of a suitable sterile 'model' seemed unavoidable. The establishment of a sound basis for such 'model' development was therefore considered to be of paramount importance, and with this in mind, a complete survey was conducted of all available relevant information, such as the chemical and physical properties of faecal material, the average daily per capita output of excreta for particular sociological groups, the average rate of defecation of particular sociological groups, etc. It was also necessary to consider other faecal solid properties not previously evaluated (such as elasticity and rigidity), which would be considered to have some relevance to faecal solid transportation. Having, in this way, arrived at the most comprehensive definition, of the typical faecal waste load, which could be achieved on the available information, each, of a series of different types of sterile 'model' solid, were subjected to transport performance tests (by means of repeated introduction and discharge through the laboratory test installation outlined in Section 4.), in order to evaluate their relative merits in the context of drainage research.

5.1 Defecation and Faecal Matter - The Available Information.

5.1.1 Frequency of Defecation.

According to Boerner and Sunderman (1949), the frequency of defecation in breast fed infants, during the first four months, usually varies from two to four times daily, after which period the infant may be trained to defecate once daily. In his study of

527 males and 598 females, aged between nineteen and thirty years, Ivy (1945) found that 96% of the males and 92% of the females defecated one or more times daily, the remainder one to three times per week.

5.1.2 Per Capita Output of Excreta.

According to Kira (1976), the faeces, of the average healthy adult (U.S.A.), vary in size from 100 to 205 mm. (4-8 inches) long by 15-40 mm. ($\frac{1}{2}$ - $1\frac{1}{2}$ inches) diameter, and in weight from 100 to 200 grams. This is in agreement with Boerner and Sunderman's (1949) findings, of 100-200 grams production from the average normal adult in 24 hours (U.S.A.) and also with the findings of Goldblith and Wick (1961), who suggested the average daily output, per normal healthy adult on a mixed diet (U.S.A.), to be 150 grams.

However, per capita output of excreta will vary according to diet, and therefore according to geography and sociological grouping. In a group of thirty 'normal' persons, on an unspecified diet, Wozasek and Steigman (1942) found the average daily faecal output to be 115 grams, while in another group of fifteen cases the daily average was 52 grams, and at no time higher than 75 grams. It is also the case that faecal output is diminished during fasting, Hawk and Bergheim (1927) having found fasting men to excrete as little as 7 to 8 grams of faeces per capita per day, while Diem (1962) suggests average daily output to be reduced for subjects on a meat diet, observations varying between 54 and 64 grams per capita. On the other hand, for subjects on a vegetarian diet, Diem (1962) suggests a per capita daily output of 370 grams, while Hawk and Bergheim (1927) suggest a comparable figure of 350 grams.

The results of a more recent survey conducted by Feachem (1979) of available information relating to faecal weights around the world, are presented in figure 5/1. It can be seen that per capita output of faecal material is much greater for Third World countries than for Western countries, and that, by and large, within Third World Countries, rural populations have by far the highest per capita output. However, for the purposes of this investigation, the values quoted for the United Kingdom, and those quoted for the United States of America, are far more relevant. Taking the

mean of all the U.K. sample averages presented in figure 5/1, a 'norm' of approximately 145 grams is suggested.

5.1.3 Chemical Constituents.

According to Boerner and Sunderman (1949) Albritton (1953) and Gradwohl (1956), faeces contain indigestible food residues (cellulose), small quantities of undigested and unabsorbed food stuffs, remains of mucosal cells, digestive fluids, bacteria and unabsorbed products of bacterial activity. Food remnants visible to the naked eye are rarely present in the formed stool of the normal person, except after the ingestion of excessive amounts of coarse fibrous vegetables, or after hasty ingestion. Goldblith and Wick (1961) suggest the following additional substances also to be present; indole, skatole, hydrogen sulphide, methylmercaptan (all odourous materials), methane, hydrogen, carbon dioxide, ammonia, proteoses, peptones, peptides, fats, minerals and trace elements and vitamins.

A resumé of the major chemical components of human faeces is presented in figure 5/2. The quantities given represent the average production of a normal adult in 24 hours, and are reported in terms of per cent of total faecal matter. It is noteworthy that only approximately 84% of the total faecal matter is accounted for, and only 32% of the dry matter is identified.

5.1.3.1 Water.

Water is the major component of faecal matter, constituting 65 to 67% by weight.

5.1.3.2 Bile Pigments.

These contribute to the colour of faeces.

5.1.3.3 Carbohydrate.

According to White and his co-workers (1954), faeces contain minimum quantities of carbohydrate, since only a very small portion of that ingested is not absorbed. Any carbohydrate which is not absorbed is generally changed by intestinal bacteria into

absorbable substances. The carbohydrate present in faeces, therefore, consists of indigestible cellulose and vegetable fibres (pentosans), and serves as a source of bulk and roughage.

No definite quantity of cellulose or pentosan has been reported to be present in faeces. This is presumably due to the variability of the amount of cellulosic material in the diet.

5.1.3.4 Protein.

Protein is usually not obviously apparent in the faeces of healthy adult humans. In an analysis of 438 stool specimens of 126 healthy students aged from twenty to twenty five years, Fantus and his co-workers (1941) found that protein was absent in 99.3% of the subjects. However, approximately 1.5 grams of nitrogen is excreted in the faeces each day (see figure 5/2). Cantarrow and Shepartz (1957) believe about one half of this nitrogen to be of bacterial origin, with the remainder representing small quantities of unabsorbed intestinal secretions and digestive fluids, mucus, food residues, intestinal enzymes and the like. Bacteria, mostly non-pathogenic, compose about one third of the dry weight of faeces under average dietary conditions, the most common bacteria found in man being located mainly in the large intestine. As it is reported by Porter (1950), that the chemical composition of micro-organisms includes a variety of proteins, it is quite certain that protein is present in faeces, although no definite total quantity has been reported in the literature.

5.1.3.5 Mucus.

Mucus can not be recognised in the normal stool, although chemical analysis indicates that small amounts are present. In the analysis mentioned in Section 5.1.3.4, conducted by Fantus and his co-workers (1941), it was found that the mucus content, of 438 stool specimens of 126 healthy students between the ages of twenty and twenty five years (120 males and 6 females) did not exceed 0.1 ml. of precipitate (from 30% acetic acid) per gram of faeces, in 90.5% of the cases.

5.1.3.6 Fat.

The fat composition of the stool of a normal person is not entirely of dietary origin, since even during starvation the stools contain fat. The part of the faecal fat contributed by the fat of ingested food depends on several factors, such as the digestibility of the ingested fat and its melting point. According to Watson (1936), the fat content may go above 40% without indicating an abnormal loss of fat.

5.1.3.7 Ammonia.

Robinson (1922) reported values, for the ammonia content of stools, ranging from 251 to 881 parts per million. The ammonia was not uniformly distributed throughout the stools.

5.1.3.8 Vitamins.

As indicated in figure 5/2, vitamins account for approximately 0.01% of faeces on average. Williams and his co-workers (1950) suggest that the greater part of this faecal vitamin content is of bacterial origin. Thiamine is in the form of cocarboxylase, while little is known of the chemical form in which the others exist.

5.1.3.9 Minerals and Trace Elements.

Minerals and trace elements are excreted in faeces in small but widely varying quantities. This variation is not surprising since it is known that the mineral content of faeces is directly influenced by variable dietary, metabolic and gastrointestinal factors. It is also known that relatively few minerals are more than 70% absorbed by man, and are thus excreted in the urine and faeces.

5.1.4 Physical Properties.

5.1.4.1 Colour (Pigments).

Boerner and Sunderman (1949) state that the colour of the stool is due chiefly to stercobilin, which is chemically identical to urobilin in urine. This is formed from bilirubin through the action of intestinal bacteria. The normal stool, in the absence

of intestinal hypermotility, does not contain bilirubin. The normal stool, on standing, darkens in colour, owing to the formation of urobilin. The type of diet and various medicaments may also cause variations in colour. Urobilinogen is a colourless reduction product of urobilin, and is excreted in both urine and faeces. Figure 5/3 details the influence of various foods and medicaments on the colour of the stool.

5.1.4.2 Odour.

The normal stool of a person on a well balanced diet has a characteristic and not too offensive odour. The ingestion of large amounts of meat or fish may render the odour more obnoxious. The faeces of vegetarians have a less disagreeable odour, while those of persons on a pure milk diet are almost odourless.

5.1.4.3 Form and Consistency.

According to Boerner and Sunderman (1949), the form and consistency of the normal stool depends on the type of food ingested, its fluid content, the muscular tonus and size of the colon, the rate of passage of material through the intestinal tract, and the presence or absence of abnormality in the anal canal. Usually, surface is rather smooth, but often it shows slight indentations. The diet greatly modifies form and consistency, and usually vegetarians pass large, thick and soft stools, whereas 'meat eaters' pass smaller, drier, often scybalous stools.

In a study correlating intestinal rate and form of the stool, Burnett (1923) found that persons with an initial rate of fourteen hours and a final rate of sixty two hours passed soft and formless stools; those with an initial rate of twenty five hours and a final rate of ninety seven hours passed formed stools with marks; while those with an initial rate of sixty two hours and a final rate of 134 hours passed stools composed of units. The stools were marked with millet seed. The time of ingestion to time of appearance of the seeds was called the initial rate; the time of ingestion to the time the seeds were last seen was called the final rate.

As regards the physical properties of faecal matter such as density, elasticity, surface roughness and rigidity, little published data is available. Tsukagoshi and Matsuo (1975) suggest that the specific gravity should be in the order of 1.00 to 1.05, and in view of the fact that water is the major component of faecal matter, this would not seem unreasonable.

5.2 Important Parameters in Respect of 'Sterile Models'.

With regard to the simulation of faecal material, in respect of transportation through a drainage system, the following parameters were considered to be of major importance.

5.2.1 Specific Gravity.

It seemed reasonable to use substitutes for excreta with values of specific gravity within the range suggested by Tsukagoshi and Matsuo (1975), as outlined in Section 5.1.4.3. A solid, having a specific gravity of less than 1.0, would obviously cause no problem in the drainage system. However, the possibility of investigating solids, of greater specific gravity than 1.05, was not ruled out, as no evidence to support this being an upper limit was available.

5.2.2 Shape, Size and Number.

As regards the shape, size and number of solids excreted by the normal healthy adult at any one time, and again having considered the lack of information, it was thought that the use of one large solid, as opposed to several smaller solids, would be the most reasonable approach for a 'worst case' analysis. Taking the figure of 150 grams, as that most widely suggested to be the average daily per capita output of excreta of normal healthy adults in Western countries (Section 5.1.2), and assuming specific gravity to be 1.05 (Section 5.1.4.3), while also assuming the average frequency of defecation to be once per 24 hours (Section 5.1.1), then;

$$\begin{aligned}\rho_s &= 1.05 \times \rho_w \\ &= 1.05 \times 0.9982 \\ &= 1.04811 \text{ gm/cm}^3\end{aligned}$$

$$\therefore V_s = \frac{150}{\rho_s} = \frac{150}{1.04811} = 143.115 \text{ cm}^3$$

where:

$$\begin{aligned}\rho_s &= \text{density of stool} \\ \rho_w &= \text{density of water @ } 20^\circ\text{C} \\ V_s &= \text{volume of stool}\end{aligned}$$

Thus, an average stool volume of about 143 cm^3 is suggested.

Taking the range of dimensions given by Kira (1976) (Section 5.1.2), the extremes of volume expected would be approximately:

$$\begin{array}{l} \text{diameter} = 1.5 \text{ cm }) \\ \text{length} = 10.0 \text{ cm }) \end{array} \quad \text{Volume} = \left(\frac{\pi \times (1.5)^2}{4} \right) \times 10 = 17.67 \text{ cm}^3 \quad \underline{\text{Minimum}}$$

$$\begin{array}{l} \text{diameter} = 4.0 \text{ cm }) \\ \text{length} = 20.5 \text{ cm }) \end{array} \quad \text{Volume} = \left(\frac{\pi \times (4)^2}{4} \right) \times 20.5 = 257.61 \text{ cm}^3 \quad \underline{\text{Maximum}}$$

Thus, the volume of stool suggested, by the figure of 150 grams average production of faecal matter per normal healthy adult at any one time, falls approximately in the middle of the range of possible volumes expressed by Kira (1976). Although the previous calculations may not seem unreasonable, it must not be forgotten that, despite intelligent interpretation of the data, assumptions had to be made in respect of specific gravity and frequency of defecation, and a 'worst case' approach had to be taken in respect of the number of solids evacuated. As regards shape, a cylindrical solid, with rounded ends, was thought to be the only reasonable possibility. It could not be asserted that, in an in-situ environment, stools would not break up or change shape during transportation, but it was essential, for any useful conclusions to be drawn from laboratory experiments, that the size and shape of simulated faeces remain constant, at known values, throughout testing.

5.2.3 Water Absorption.

If any material, used in the manufacture of simulated faeces, absorbed water, it was considered essential that the degree of retention of that water be either total, or zero, in order to avoid inconsistencies during experiments. It must not be forgotten, that the water content of human excrement is not simply absorbed, but is chemically combined, and that non-uniform water retention over the length of a simulated faecal solid, could well result in one end of the solid riding higher in the water than its counterpart, thereby giving rise to non-representative transport performance.

5.2.4 Surface Roughness.

Surface roughness could only be considered as an important factor influencing the carriage of a solid through the drainage system, particularly in cases of solids having relatively large specific gravity. As no published data was available on the subject, surface roughness had to be judged instinctively when considering the suitability of different materials as substitutes for excreta in the laboratory situation.

5.2.5 Durability to Friction.

In order to save both time and material, and in view of the difficulties encountered in forming different materials into the required shape, it was considered desirable to use a few specially formed solids repeatedly, rather than to dispose of each solid after a single W.C. operation. Thus, it was essential, that any material adopted be durable to friction, and not subject to erosion through continuous use.

5.2.6 Rigidity.

Although no published information was available, it could only be concluded that the normal stool would be reasonably flexible, but that, having no great cohesive strength, would probably fracture, as often as not, when subject to appropriate externally applied forces. However, to allow for successful manufacture and repeated use, it was essential that any 'model' stool have reasonably good cohesive strength. Thus, in order to ensure that cohesive strength

and rigidity combined did not present an uncharacteristic resistance to applied 'bending' forces, it was also essential that any such 'model' be reasonably flexible.

5.2.7 Elasticity.

There can be little doubt, that the normal stool would display almost total inelasticity. As an elastic solid could encounter serious problems in negotiation of the W.C. trap, it was important that any 'model' solid also be inelastic.

5.3 Materials Considered as Substitutes for 'Live' Solid Waste.

The following materials were each employed as the base for development of a 'model' solid;

- (a) Flour putty, in combination with each of three different 'filler' materials (polystyrene, sawdust and paper maché).
- (b) Potter's clay, in four different varieties (Buff, Reducing St Thomas, a Raku/Crank mix and a Craft/Crank mix), each in combination with each of three different 'filler' materials (polystyrene, sawdust and paper maché).
- (c) Polyvinylalcohol Powder, in three different grades (Gelvitol 1-30, Gelvitol 20-90 and Gelvitol 40-10), each without a 'filler' material, and each in combination with each of three different 'filler' materials (polystyrene, sawdust and paper maché).
- (d) PolyVinylalcohol Sponge, in three different grades (based solely on pore size).
- (e) Fakazell, in two different density grades.
- (f) Various Sanitary Protection Products.

5.3.1 Flour Putty.

Flour putty was made up from a mixture of flour, water, salt, cooking oil and bicarbonate, all of which was heated slightly to obtain a better consistency. When stored in an airtight container, the resulting 'putty' retained its original characteristics for two or three months, but when left in air hardened relatively

quickly, and in doing so, lost its cohesive quality. Specific gravity was found to be slightly higher than required (see figure 5/4), and consequently attempts were made to produce composite solids, through combination with each of three different 'filler' materials (polystyrene, sawdust and paper maché), in order to reduce overall specific gravity. Filler materials were mixed into the 'putty' as ground particles and although great care was taken to ensure consistent proportions throughout a mix, it was found that this could not easily be achieved. The surfaces of all such composite flour putty solids were extremely adhesive, especially when wet. After immersion in water for any length of time all flour putty solids began to dissolve and disintegrate.

5.3.2 Potter's Clay.

The weights and volumes, of samples of each of the four different types of potter's clay (Buff, Reducing St Thomas, a Raku/Crank mix and a Craft/Crank mix), were measured, and the relevant densities calculated (see figure 5/4). Specific gravity, in all cases, was in excess of 2.0. Potter's clay could therefore only be used in combination with a lighter 'filler' material. Composite solids were manufactured in the same manner as outlined in respect of 'flour putty' (section 5.3.1) and by use of the same 'filler' materials. After the addition of sufficient 'filler' to reduce specific gravity to the required level, composite solids, irrespective of the particular combination of clay type and filler type, were found to be extremely rigid, but to have very little cohesive strength. These solids fractured easily, even in consequence of the most gentle handling. Immediately upon immersion in water, all clay solids began to dissolve but when allowed to dry out, set extremely hard.

5.3.3 Polyvinylalcohol Powder.

Polyvinylalcohol powder (P.V.A.) can be obtained in various different grades, each being of slightly different chemical make-up, and therefore having slightly different physical properties. Three grades of P.V.A. powder were obtained, spanning the range of possible different grades. To form suitable solids, the powders were each mixed with the minimum possible amount of water, to

achieve a good workable consistency, and were then compressed into moulds to achieve the required shape. It was then necessary to allow several hours for the solids to set, as the mixture of P.V.A. powder and water produced an adhesive. Irrespective of the grade of powder employed, the resulting solids had considerable cohesive strength, and were almost totally rigid. Unexpectedly, these solids were found to be absorbent, becoming rather more flexible after several hours immersed in water, without any great loss of cohesive strength. If then placed in air, it took a similar period of several hours for the solids to re-assume their 'dry-state' condition.

The specific gravities of these solids were very close to the required 1.05 (see figure 5/4), but some adjustments were attempted by the addition of various 'filler' materials. Polystyrene, sawdust and paper-maché, in the form of ground particles, were each independently combined with P.V.A.. The resulting solids were rather lighter than required, as had been expected, and displayed rather poor cohesive qualities, tending to fracture rather than bend, even when in a 'wet-state' condition, under the very lightest pressures. The surfaces of all P.V.A. solids, whether or not they incorporated one or another of the various 'filler' materials, became very adhesive when wet. A variety of the different 'P.V.A.' and 'P.V.A./filler' solids are shown in Figure 5/5.

5.3.4 Polyvinylalcohol Sponge.

As well as being available in powdered form (Section 5.3.3), P.V.A. can be obtained as sponge. Tsukagoshi and Matsuo (1975) did in fact use P.V.A. Sponge as a substitute for excreta in their work on water saving type closets. Blocks of P.V.A. sponge were obtained, in three different grades based solely upon pore size (each block having approximate dimensions; 90 mm. x 40 mm. x 130 mm.): On enquiring of the manufacturers the grade, based upon chemical make-up, of the P.V.A. from which the various sponges were produced, it transpired that this factor was not vital to the production of P.V.A. sponge, and indeed that sponges were produced from P.V.A. of quite

random proportions of the various chemical grades.

When wet, P.V.A. sponge was found to be soft and pliable, much as a household sponge, but when allowed to dry out, became hard and totally inflexible. Considerable shrinkage occurred during the process of drying out, the fine grade sponges being most affected, and the coarse grade least (see Figure 5/6).

Difficulties were incurred in forming the required shape, from the blocks of dry sponge, because of distortion accompanying shrinkage.

When re-soaked in water the sponges reverted to their original shape. The ideal would have been to cut the required shapes from the blocks while wet and undistorted, but, because of the soft and flexible condition of the sponge when wet, this was not possible. The required shapes had to be formed while the sponge was dry, even though distorted, and this was done using a lathe.

It was essential that the sponges be dried out in such a way as to reduce distortion as far as possible. The shaping process was carried out in several stages. The 'models' were cut roughly to shape from the dry and distorted blocks. Next the partially shaped sponges were thoroughly soaked, and then allowed to dry out for a period of about 48 hours. The soaking caused them to revert to their undistorted form, and because of their reduced size the distortion which occurred during this drying stage was greatly reduced. When completely dry the P.V.A. was again shaped more closely to the required dimensions. This process of soaking, drying and shaping, was repeated, several times, until the P.V.A. sponge 'models' were considered to meet the requirements of shape and size, details of which are given in Figure 5/6. Final adjustments, and rounding off the ends, were carried out with a hand file.

Figure 5/7 shows some of the early attempts at producing substitutes for excreta from P.V.A. sponge. The models shown had been cut exactly to the required symmetrical shape whilst dry, and were then thoroughly soaked. The distortion which occurred is plainly visible.

Figures 5/8 and 5/9 show the original blocks in 'wet-state' and 'dry state' respectively, and Figures 5/10 and 5/11 each show the six 'models' (two each of fine, medium and coarse grades), which were accepted as meeting the requirements of shape and size, whilst in 'wet-state' and 'dry-state' conditions respectively.

As P.V.A. sponge was extremely absorbent, it was thought necessary, in consideration of specific gravity, to measure true specific gravity, 'apparent' specific gravity, and saturated bulk specific gravity, where 'apparent' specific gravity was taken to be that of a damp sponge. In order to calculate values of true specific gravity, true sponge volume was measured by immersing each solid in turn in a measuring cylinder containing water, and recording the difference in water level after having allowed sufficient time for the sponge to become completely saturated (and having assisted the expulsion of air by the use of glass rods). P.V.A. Sponge 'models' would not, of their own accord, retain total saturated water content when placed in air, and this caused some difficulty in measurement of saturated weight. However, a close approximation, to saturated weight, was obtained by applying a thin film of waterproof material around each solid, whilst totally immersed and saturated, thereby ensuring complete water retention on removal to air. In each case, the waterproof film was weighed separately, and the solid measurement for weight adjusted accordingly. In order to calculate 'apparent' specific gravity, each sponge, in turn, was saturated in water, but then removed and allowed to drain for several minutes. This left the sponge with greatly reduced water content, but still damp, and it would have taken a matter of several hours for the remaining water content to have been removed. While in this damp condition, each sponge was weighed and then placed in a measuring cylinder to determine volume (each sponge having been allowed to completely saturate prior to the measurement of displacement). Details of 'apparent' specific gravity are presented in figure 5/6.

Apparent specific gravities, of P.V.A. sponge 'models', were artificially adjusted, where necessary, by the insertion of small lead weights. These weights were distributed as evenly as possible along the length of each solid in question. It can be seen, from figure 5/6, that there were certain discrepancies between the 'apparent' specific gravities of solids of the same grade, which were in fact produced from the same block of P.V.A. sponge. Although these discrepancies were very small, and therefore of little consequence, it is suggested that this situation arose as a result of uneven distribution of the variously sized sponge 'pores', an unavoidable consequence of the method of manufacture.

5.3.5 Fakazell.

Fakazell is a paste like material, developed and produced by Knoblauch (1980), which was primarily intended for test evaluation of W.C. pan efficiency. This material consists of approximately 20% solid substances (mainly cellulose), and 80% water, and is prepared from two components (a filling substance, and a binding substance). The density of Fakazell is variable, but the material is generally produced in only two different density grades;

density, ρ = 1.03-1.05 kg/litre (FAKAZELL 105)

" ρ = 0.95-0.97 kg/litre (FAKAZELL 95)

Fakazell was supplied, by kind permission of Prof. Knoblauch, with a special 'mush press'. This was employed to form solids of the required shape during introduction to the W.C. pan. Fakazell is flexible and inelastic, and has consistency and surface similar to what might be expected of faecal material.

5.3.6 Sanitary Protection Products.

Swaffield (1975) and Wakelin (1978) both employed 'maternity pad' solids for their research, basing their choice of solid on the premise that this represented a 'worst case' system load. Such solids are easily obtainable in large quantities, and allow that a new solid may be used for each test run (W.C. discharge).

Sanitary Protection Products are reasonably flexible, relatively inelastic, and although compressible roughly maintain basic shape and form during transportation. As such products are available in a multitude of different shapes and sizes, so different levels of performance may be achieved through the use of the different products. Sanitary towel raw materials are basically 'cellulose' - fillings of tissue, fluffing pulp with a non-woven cover. There is sometimes a plastic film inside the towel as a fluid barrier. Plastic can also be used as a release tape to cover the pressure sensitive adhesive on the back of the towel. The non-woven cover can be very specialised -either completely non-absorbent polyesters or a 'flushable' cover which disperses after some time in water. Rayon or a rayon/cotton mixture is the usual fibre for tampons.

6. DISCUSSION OF LABORATORY RESULTS.

6. Discussion of Laboratory Results.

Prior to a discussion of particular results, it must be clearly understood that, in examination of waste load performance different avenues of investigation are possible. An obvious approach, hereinafter referred to as the 'simulation approach', would be to attempt to produce an exact 'sterile' mean equivalent of the typical 'live' waste load. This approach requires, that all relevant information, with regard to precise definition of the mean 'live' waste load, should be available. No environment or situation can be modelled, unless an exact definition of whatever is to be modelled is available. Having achieved such an equivalent load, all solid parameters could thenceforth be eliminated from investigations. A design method could be developed, for above ground drainage systems, through concentration of future research on the effects, of various installation parameters (such as W.C. Design, W.C./Discharge-Pipe Geometry, etc.), upon the performance of this 'equivalent' load.

A second avenue of investigation, hereinafter referred to as the 'individual parameter approach', would be to investigate the effects upon resulting transportation of variations in particular details of solid make-up. For instance, one such series of tests might involve gradual variation of solid density. To follow this approach would require the use of several different material types of solid, each suitable for easy adjustment of one particular parameter, though none need be an exact 'equivalent' to faecal material in any other aspect of physical make-up. This approach could only result in a better understanding of waste solid transportation, but results could not be directly related to an 'in situ' environment, and could not be used to produce a realistic design method for above ground drainage systems.

A third avenue of investigation, herein after referred to as the 'calibration approach', would involve assessment, not of the average make-up of 'live' waste loads (as in the 'simulation approach') but of the transport performance of 'live' waste loads. 'Live' waste load performance could be monitored, over a particular given arrangement of pipework, and the resulting mean level of

transportation could be matched to that of some 'model' solid, which, perchance, performs identically. Many different 'models' could be tested, over the same particular given arrangement of pipework, until a suitable 'calibrated equivalent' was found. Thus, in future laboratory work, intended to investigate the effects upon solid transport of the different installation parameters (details of 'system geometry'), results obtained, using the 'calibrated equivalent' 'model' solid, could be taken to be representative of 'live' waste load performance. A realistic design method could then be developed.

It can only be concluded, from scrutiny of the relevant information presented in Section 5.1, that insufficient data is available to allow successful pursuance of the 'simulation approach'. Not only can the physical characteristics of faecal material not be adequately defined, but absolutely no information is available concerning such aspects as the typical number, shape and form, of the typical faecal solid output (of the typical healthy adult at any one time), or as the average amount of toilet/tissue paper material which might be expected per W.C. discharge. Thus, the various different materials, outlined in Section 5.3, could only be evaluated in relation to their usefulness to either of the 'individual parameter' or 'calibration' approaches.

Flour-putty solids displayed rapid dissolution, when immersed in water, thus indicating that repeated use would not have been possible. Surfaces became extremely adhesive, during transportation, resulting in random retardation of solid transport on the occurrence of any direct contact with pipe walls. Such behaviour would not be expected of 'live' waste loads and, being random, could not be tolerated in controlled laboratory experiments.

Solids manufactured from Potter's-clay, irrespective of clay type, displayed a tendency to fracture in negotiation of the trap of the W.C. pan. Again, this could not be tolerated, in controlled experiments, since the degree of solid break-up was a totally random variable. Such solids could only be used in combination with one of a selection of lighter 'filler' materials (see Section 5.3), due to the high values of density associated with Potter's clay, and this served only to exaggerate the problem of solid

fracture. Resistance to friction was observed to be extremely poor, thus rendering such solids unsuitable for repeated usage.

The physical properties of solids manufactured from P.V.A. powder, irrespective of chemical grade (see Section 5.3.3), were found to vary in accordance with the level of water retention at any particular moment. When in a 'dry state' condition, such solids were almost totally rigid, and even when saturated, were rather more difficult to bend than would have been desired. Surfaces became slightly adhesive when wet, but all solids maintained their basic shape and form throughout preliminary tests, and direct contact with pipe walls did not inordinately affect transport performance. All P.V.A. powder solids were extremely elastic. Numerous W.C. failures occurred, in consequence of rigidity and elasticity, only very small solids successfully negotiating the trap. The addition of various lighter 'filler' materials caused unwanted reduction in specific gravity, since that of ordinary P.V.A. solids was already very close to the required 1.05, and rather than affect loss of rigidity, introduced a tendency for solids to fracture.

The 'models', manufactured from P.V.A. sponge, initially appeared to have far greater potential than any of the different material types of solid previously discussed. However, it could only be considered that 'true specific gravity' was not a relevant measure of specific gravity during transportation, since solids, at all times, retained a minimum water content. 'Saturated bulk specific gravity' was not relevant, since solids often deposited a proportion of water content, during transportation, on a part of a solid rising above the surface of the carrying water. 'Apparent specific gravity' was not a relevant parameter (taken to be the specific gravity of a 'damp' sponge), since this could take no account of buoyancy effects resulting from positive retention of air. Comprehensive tests were conducted, as reported by the author in conjunction with Swaffield (1978), using P.V.A. sponge 'model' solids of each of the three different available grades (based solely upon pore size). The most apparent phenomenon observed throughout all tests, but most pronounced in the case of fine grade sponges, was the tendency for solids in transit to 'nose dive' the 'tail' of a solid rising to the surface of the carrying water, and the forward travel of the water

propelling the 'nose' of the solid hard against the bottom of the pipe. This greatly increased the solid to pipe friction, and, in the majority of cases, caused premature deposition of the solid. This phenomenon was attributed to positive retention of air, resulting from the tendency of the flow mechanism to lift the tail of any solid during the initial, and most vigorous, period of transportation.

A further problem, experienced with P.V.A. sponge 'models', was that apparently identical solids were observed to perform differently. One 'course grade' P.V.A. sponge 'model' consistently became wedged in the trap of the W.C. pan, while an apparently identical solid consistently cleared the W.C. pan on the first flush. The elasticity of each of these solids was measured, and that of the first solid was found to be by far the greater of the two. This was undoubtedly the cause of the pronounced difference in performance, and could only be attributed, either to inconsistent manufacturing techniques, or to an inability of the material to withstand handling and usage. In either case, it could only be concluded that such solids were not suitable for use in laboratory investigations.

With regard to such aspects as appearance, consistency, flexibility and inelasticity, Fakazell solids seem to model faecal material reasonably well. Fakazell is therefore the most obvious candidate, of the available materials, for use in a 'simulation approach' to drainage research. However, as previously outlined, since insufficient information is available to allow quantitative definition of the properties of faecal material (in terms of either the range of possible values or the 'norm' in any particular situation), and since virtually no authoritative data exists in respect of such aspects as the typical number, shape and size of faecal solids (in relation to the contents of a typical W.C. discharge), pursuance of a 'simulation approach' was not considered to be available option. No unusual flow mechanisms were observed during tests which employed Fakazell 'models', except that, when more than one solid was discharged per flush, one Fakazell model quite commonly by-passed another (whereas it was found, from subsequent 'on-site' investigations (Section 10.3.3), that this phenomenon did not occur during multiple solid faecal material transportation). None the less, since such

solids had no great cohesive strength (being subject to occasional fracture), and since maintenance of consistent shape and form could not be guaranteed throughout the course of transportation, the usefulness of Fakazell 'models', to either of the 'individual parameter' or the 'calibration' approaches to drainage research, was considered to be somewhat limited.

As outlined in Section 5.3.6, Swaffield (1975) and Wakelin (1978) both employed 'maternity pad' solids for their research, basing their choice of solid on the premise that this represented a 'worst case' system load. Although none of the basic sanitary protection products available on the market could be considered to 'simulate' either faecal material, or 'live' waste loads in general, such 'models' can only be considered to have definite potential in respect of both of the 'individual parameter' and 'calibration' approaches to drainage research. Swaffield's (1975) original work confirmed the practicality of employing sanitary protection products, as the basis for an empirical design method, and Wakelin (1978) continued, on the same basis, to achieve an understanding of the basic mechanism of waste solid transport (see Section 2.2). The choice of a sanitary protection product, for this method of approach to drainage research, can only be considered to have been a reasonably sound judgement.

A series of investigations were conducted by the author in conjunction with Howarth, Swaffield and Wakelin (1980) aimed at the development of a set of flushability criteria for sanitary protection products. This work, which was undertaken on behalf of the Association of Sanitary Protection Manufacturers (A.S.P.M.), involved performance testing of an extremely wide range of available products, including maternity pads, sanitary towels, mini-pads, tampons and disposable diaper materials. It was found that, in all cases, sanitary protection products conformed to the relationship, for 'zone 2' deceleration, formulated by Wakelin (1978), see Section 2.2. However, although the same basic mechanism of solid transport was displayed throughout, the actual level of performance varied considerably, from case to case, reflecting particular individual solid parameters. Such products were found, by and large, to display no particular difficulty in negotiation of the trap of the

W.C. pan, and excepting tampons, were both flexible and inelastic (although subject to minor variations, in these respects, from one product to the next), and yet maintained basic shape and form throughout transportation. As sanitary protection products are available in bulk quantities, are relatively cheap, and have repeatable characteristics, no reprocessing of material or complicated initial 'model' manufacture was necessary.

This investigation, for A.S.P.M., highlighted the suitability of sanitary protection products as 'models' which could assist in pursuance of a 'calibration' approach to drainage research. Presupposing the achievement of data concerning the performance of typical particular 'live' waste loads, for a particular arrangement of 'system geometry', different sanitary protection products could be tested, over an identical arrangement of 'system geometry', and, from the wide variety of mean performance levels which would inevitably result, specific products could be selected which most nearly matched the average performance levels of the relevant particular 'live' waste loads.

A further series of tests were conducted, in which the maternity pad was employed as the basic 'model', to evaluate the suitability of sanitary protection products, for use as 'models', in an 'individual parameter' approach to drainage research. The initial aim was to attempt to determine the effects, upon 'model' solid transport, of variations in solid dimensional parameters. It had been envisaged, at the outset, that each of a particular section of differently sized sanitary towels, could be tested, and that the resulting different average performance levels could be analysed according to parameters of length, width and thickness. However, there were certain problems in relation to this approach. Firstly, a sufficient number of products, which, for each particular dimension, varied in respect of no other dimension, were simply not available. This would have required, that at least two dimensional parameters be investigated simultaneously, thereby considerably complicating analysis of results. Secondly, different sanitary towels were either manufactured of slightly different proportions of the component materials, or were manufactured to slightly different designs. Thus, had two different types of towel been dimensionally identical, they could have been expected to give

rise to different levels of performance, simply in consequence of manufacturing differences.

The maternity pad was therefore adopted, as the basic 'model' for this investigation of solid dimensional parameters, and dimensional variations were achieved by means of either simply cutting pads as required, and then re-sealing the outer covers, and/or combining pads together, and then sealing edges by connecting outer covers. Combination of pads was preferred, over dissection of pads, since this did not destroy the normal finish and seal of such solids. However, this work, reported by the author in association with Swaffield (1978), proved less than sufficient to allow quantitative understanding of the relationships between model solid transport and solid dimensional parameters. That this was the case, can be attributed solely to the choice of 'model'. It was not possible to detect small adjustments, in any particular solid dimensional parameter, from resulting transport performance, and this was a direct result of inconsistent sealing and finishing to the constructed 'models'. As sanitary protection products are composite solids, qualities of absorption can be severely effected by allowing direct exposure of normally centrally situated component materials to water. As minor inconsistencies, in construction of models, caused minor variations in resulting performance levels (from that which would have occurred had finishing techniques been more sophisticated), only very large step adjustments in model size, achieved with the least possible interference to solid structure, resulted in variations in performance which were not confused by absorbancy effects. Thus, fewer differently sized 'models' were successfully monitored, than would have been necessary to allow development of quantitative relationships.

Nonetheless, the qualitative information, resulting from this 'individual parameter' investigation, can provide considerable insight into the relative importance of adjustments to particular dimensional parameters. Figure 6/1 presents the range of average velocity profiles associated with the successful tests of variously sized 'models' (as constructed from maternity pad solids). It can be seen that, first and foremost, solid mass would appear to be of

fundamental importance, over-riding, to a great extent, the parameters of solid shape. Figures 6/2, 6/3 and 6/4, each present a selection of those average velocity profiles presented in figure 6/1, each selection representing step increases in solid mass, from one half normal to that of the normal maternity pad, where such increases are manifested as increases in one particular dimensional parameter only, the relative dimensions being length, width and thickness, respectively. It is immediately apparent, that an increase in either length, width or thickness of solid, when combined with a proportional increase in total mass, caused an overall reduction in the efficiency of resulting transportation. However, it is also apparent that, at least in respect of the range of mass adjustment considered, variations in mass, manifested as variations in solid length, caused far less variation in transport efficiency,* than did similar mass variations manifested as variations in either of solid width or thickness. This seemed to suggest that, for solids of identical mass, a long and thin solid would perform better than a short and thick solid (of identical width) and that a long and narrow solid would perform better than a short and broad solid (of identical thickness). Figures 6/5 and 6/6 respectively, present just such constant mass comparisons (using the relevant data selected from that presented in figure 6/1), and it can be seen that both of these suggestions were confirmed.

* 'transport efficiency', in this context, simply meaning the level of performance in terms of mean solid velocity at any particular point along the drain.

7. LABORATORY STUDY CONCLUSIONS.

7. Laboratory Study Conclusions.

It could only be concluded that, of the possible different approaches to drainage research, that of direct 'simulation' was the most impractical. Not only would it have been necessary to first conduct extensive investigations in respect of the physical characteristics of faecal matter (in terms of both the range of possible values of each relative parameter, and the particular 'norms' associated with particular sociological groups or National populations), but it would also have been necessary to conduct similarly widespread investigations, in respect of the composition of different types of 'live' waste load, leading to quantitative definition of the various component materials (faecal matter, toilet tissue paper and other 'rogue' materials). Waste loads could only be expected to vary according to 'user activity', and each recognisably different type of waste load would have had to be defined in terms of the range, and 'norms', of such parameters as the number of solids per flush, and the material type, weight, shape and size of solids.

Not only would the scale of such investigations, as outlined, have been immense, but, having full regard to the avoidance of any possible health hazard, the problems, inherent in procurement, handling and eventual disposal of raw sewage (which could not be avoided), would have been many and difficult, if not insoluble. Without such information as outlined, to allow complete definition of 'live' waste loads, no attempt at direct 'simulation' could be considered worthwhile. Although, on the basis of known facts, it was possible to rule out certain material types of solid, as candidate 'sterile models' for a 'simulation' approach to drainage research, due to the current lack of relevant information, there were other material types of solid which could not be totally ruled out (such as Fakazell, see Section 5.3.5 and Section 6), but which, nonetheless, could in reality be less suitable than those already eliminated from the list of possible candidate materials.

In respect of either of the 'individual parameter' or 'calibration' approaches to drainage research, candidate materials were more easily evaluated. However, it must be remembered that, for such purposes, 'models' need not mirror the characteristics of either faecal material or toilet/tissue-paper, it simply being required, that

materials be suitable for laboratory use (being sterile, and either re-useable or easily available/manufacturable in bulk), give rise to no unusual flow mechanisms, introduce no random elements to performance (other than those inherent to W.C. discharge), and are to some degree adaptable (allowing that different specific levels of performance may be arranged, in the case of a 'calibration approach', or that one or more particular solid parameters may be adjusted, to specific values, without the introduction of side effects, in the case of an 'individual parameter approach').

Flour putty solids were found not to be suitable for re-use, and could not easily be manufactured in bulk. Such solids also failed to maintain consistent shape and form during transportation. Solids produced from a potter's clay base displayed similar failings, at least in effect if not in cause. P.V.A. powder based 'models' were found to be far too rigid, which caused problems in negotiation of the trap of the W.C., and P.V.A. sponge 'models' were subject to buoyancy effects (unusual flow mechanism), were greatly affected by frictional resistance resulting from contact with pipe walls, and displayed variable and uncontrollable elastic properties (a factor influencing W.C. clearance). Fakazell solids failed to maintain consistent shape and form. Thus, not one of these different material types of solid could be considered to be of value to either of the 'individual parameter' or 'calibration' approaches to drainage research. In fairness, it must be pointed out, that the initial concept, behind the selection of each of these different material types of solid, was probably one of direct 'simulation', the total impracticality of which has already been discussed. The same conclusions must equally apply to other similar 'models', which have previously been employed in drainage related research, such as natural sponge, polystyrene coated in plasticine (B.R.E.), or the glitterwax and plasticine composite of Burgess' (1963) study into W.C. splashing.

Sanitary Protection Products, on the other hand, were found to have some limited use in respect of an 'individual parameter' approach to drainage research, limited due to the composite nature of such products, but to have considerable potential in respect of a 'calibration' approach.

It was therefore concluded that pursuance of a direct 'simulation' approach to drainage research was simply not practical, that, although pursuance of a totally laboratory based 'individual parameter' approach could prove extremely illuminating, the problems involved would be many and difficult, and in the final event, results could not be related to practical 'live' installations, and that a 'calibration' approach seemed to offer the greatest prospect of successful transition, from a purely theoretical understanding of the mechanism of waste solid transport, to the development of a practical design method.

8. APPARATUS AND INSTRUMENTATION - DEVELOPMENT FOR 'SITE-WORK'.

8. DEVELOPMENT FOR 'SITE-WORK'.

On relocation of the experimental program, in order to monitor 'live' installations in situ, a completely different test environment was encountered. Under these conditions it was necessary, that new test procedures and monitoring methods be developed, major modifications, to the apparatus and instrumentation employed, being required to achieve this. The details outlined in this section, unless stated otherwise, apply to both of the facilities which were monitored during the course of site investigations.

8.1 Pipes and Fittings.

The decision to monitor the particular installations chosen was not made on grounds of suitability of discharge pipework or material, but on grounds of having acceptably high usage patterns so as to allow sufficient data to be collected in the time available, see Section 9.2. It was therefore necessary to construct new pipework installations to service the facilities to be monitored. The new installations were routed so as to achieve the maximum straight length possible, in each case, while conforming to the specifications of the laboratory test rig as closely as possible. The previously existing services employed 100 mm. I.D. spun Cast Iron (C.I.) pipework. Marley 100 mm. I.D. transparent U.P.V.C. pipework, as described in Section 4.2, was used to construct the new service systems. This allowed for close observation of solids in transit, and for comparison of results with those gained in the laboratory. The relative ease of installation, using U.P.V.C. pipework, was a considerable advantage under the difficult site conditions. All connections between lengths of pipe were carefully constructed, as described in section 4.2, using Marley SE400 ring seal couplers.

The C.I. pipework serving each W.C. to be monitored was cut off at about 50 mm. below the ceiling level of the floor void. The C.I. pipe was then cut back as far as was necessary in each particular case, being capped off using Glynwed Timesaver GT70 blank end and GTO1 two piece coupling (having a synthetic rubber gasket), to allow accommodation for the new U.P.V.C. discharge pipework.

In each case the the protruding C.I. pipe below the W.C. was then connected to a short length of transparent U.P.V.C. pipe using a Glynwed GTO1 coupler, and to the bottom of this vertical pipe was fitted a Marley SB41 92½° bend. The length of the vertical U.P.V.C. pipe was the minimum necessary to facilitate good connection to the coupler and to the bend, thus ensuring that the vertical drop at outlet from the W.C. was kept at a minimum. The horizontal outlet from the 92½° bend was then connected, with an SE400 coupler, to the horizontal length of U.P.V.C. discharge pipework. Figure 8/1 illustrates this arrangement. For each of the facilities monitored, male and female, two W.C. pans were connected into the newly constructed discharge pipework, the second discharge joining that from the first via a Marley SY460 135° branch, as shown in Figure 8/2.

A Marley SY401 92½° branch, as illustrated in figure 8/3, was fitted at the end of the monitored length of pipework. In the laboratory environment this junction was intended to simulate connection to a vertical stack, and both the top and bottom connections to the branch were left open to atmosphere. Under site conditions the top connection to the branch was terminated using a Marley SE41 socket plug. A short length of transparent U.P.V.C. pipe was then fitted to the bottom connection of the branch using a Glynwed GTO1 coupler. This particular type of connection was employed, instead of a Marley SE400 coupler, so as to allow for easy disconnection at this point after installation, see section 8.2. A Marley SB41 92½° bend, fitted to the bottom of the short length of vertical pipe, turned the flow back to a horizontal plane. The discharge was then piped straight to the nearest existing 100 mm. I.D. C.I. soil pipe. As shown in Figure 8/4, connection to the existing main was achieved via a C.I. Glynwed GTO6 135° branch, employing GTO1 couplers, a Marley SB47 adjustable bend being used to align the U.P.V.C. discharge pipe to the branch connection.

The monitored pipework serving the female facility was constructed as one straight length, but a Marley SB41 92½° bend was incorporated into the monitored pipe from the male facility. Two off Marley UF42 access units, each having 150 mm. access entry to 100 mm. I.D., and having uniform and smooth internal profile when sealed, were included in the pipework constructed for the female facility. However, as no situation arose, during the course of experiments, requiring the use of these units, it was considered unnecessary to incorporate access into the service pipework for the male facility. All pipework used in both installations was in standard 3.0 m. lengths, these being cut as necessary to accommodate fittings where required.

8.2 Discharge Pipe Support System.

At the outset of the site investigation it had been intended to support the installed pipework from simple frames, having built in vertical adjustment to facilitate easy setting of gradient, bolted to the void ceiling. On examination of the site conditions it was discovered that the void ceilings consisted of load bearing reinforced concrete beams and precast aerated concrete infill panels. It was considered unacceptable that any fixings be bolted into the structural beams. The aerated concrete proved inadequate as a support medium, many of the previously existing fixings for other services being found to be either loose or completely free. As any movement of the frame, supporting the pipework to be installed, would have adversely affected the precise adjustment required to maintain gradient, it was decided that the new installations could not be hung from the ceiling.

A support system was designed, as can be seen in Figure 8/5, based on two vertical lengths of 'speedframe', having a horizontal connecting bar at high level, and fitted with adjustable 'feet' at top and bottom of each vertical 'leg'. The frame could then be placed in position and fixed by extending the 'feet' until the frame was firmly wedged between floor and ceiling. Two lengths of 8 mm. studding were then bolted to, and hung from, the horizontal connecting bar.

The discharge pipework was then fixed between the two lengths of studding, clamped in a Marley JB42 two piece bracket packed by a length of SC621 barrel clip collar. The bolt holes in the two piece brackets were drilled out to 9.5 mm. (3/8") to accommodate the 8 mm. studding. In this way the pipe could be raised or lowered between lengths of studding, and clamped at the required height by tightening the nuts on each length of studding above and below the bracket.

The pipe support system employed in the laboratory utilised one length only of studding per pipe support bracket, positioned vertically above the centre line of the pipe and moving with the pipe, in relation to the support frame, in adjusting for height. Under site conditions the headroom available was insufficient to allow for vertical movement of the studding. The new support system, employing two lengths of studding per pipe support bracket, as previously described, allowed for the pipe to be vertically adjusted in relation to the now stationary studding lengths.

A level survey was undertaken of the ceiling height, in order to set up pipe gradient as required, levels being taken at particular points adjacent to the vertical legs of the pipe support frames. Having thus made allowance for ceiling level variation, the distance from the underside of ceiling to top external surface of pipe, as required at a particular stand position and distance from the W.C. for a particular gradient, could be calculated. The distance could then be measured and marked off, down the relevant leg of the support frame, from the ceiling. By levelling between the marked leg and the top of the pipe with a spirit level, the pipe could be adjusted to the required height. The maximum variation in ceiling level observed, over the length of the pipework installed to service the female facility, was 37.0 mm. The corresponding figure for the male installation was 31.5 mm.

In order to allow free movement of the monitored length of pipework while setting up or changing gradient, the Glynwed GT01 coupler at the end of the monitored length of pipework, see Figure 8/3, positioned between the bottom of the Marley SY401 92½° branch and the top of the short length of vertical transparent U.P.V.C. pipe was removed. This allowed for easy removal of the short vertical pipe also. The length of monitored pipework could then be set to the required gradient, a new length of transparent U.P.V.C. pipe being cut to fit the new vertical clearance, and the system being re-sealed by replacement of the Glynwed coupler.

Due to the myriad of other service systems housed in the floor voids, the pipework support frames could not always be positioned exactly as required. However, the maximum distance between support frames was limited to 1.8 m.

8.3 Measurement of 'Flush Ahead of Solid'.

Due to the fact, that solids discharged through the in situ installations would be of faecal origin, for health reasons it was not considered acceptable for the discharge pipework to be open to atmosphere at any point. Considering the method of measurement of flush ahead of solid employed in the laboratory, as outlined in section 4.1.5, the difficulties involved in attempting to adopt this method for operation in a sealed enclosure can be appreciated. Some form of waste pump would also have been needed to re-introduce the collected discharge back into the drainage system. The fact, that a proportion of the flushes to be monitored would now contain more than one solid each, would have added to the task of translating data to meaningful results. The intricate array of apparatus and instrumentation required to solve this problem, would have cost a great deal in development time as well as material expense.

Negotiations would then have had to be undertaken to gain acceptance, for use in the hospital environment, from the relevant health authorities. It was considered unlikely that such a monitoring method could have been designed which would have allowed the operator concurrently to measure the required solid transport data. It was decided, that flush ahead of solid could not feasibly be monitored, within the scope of this work, under the prevailing site conditions.

8.4 Measurement of Solid Velocity.

The automated method of recording travel time between set points, based on the use of timer counters and O.T.T.L.E. as described in section 4/6, was designed to monitor single solid flushes only. 'On site', it was anticipated that many flushes would be multi-solid discharges. The automated system could have been adapted to record several solids per flush, but only so long as the respective order of solids remained unchanged throughout the discharge, i.e. provided no solid 'overtook' any other solid. This basic assumption could not be guaranteed to be the case. Solids tested in the laboratory were always of known size and shape, it being necessary to calibrate the monitoring system to suit the range of sizes of voltage pulses associated with any particular solid type. Under site conditions solids could be of widely varying size and shape, therefore, initiating voltage pulses of varying size and shape. There would undoubtedly be some small solids which would initiate voltage pulses smaller than those generated by water interference. Amid the prevailing water initiated voltage pulses, an automated monitoring system could in no way be organised to recognise, and switch correctly, for such a variation of solid initiated pulses. It was therefore considered necessary for all photo cell outputs to be fed to a pen recorder, thus providing a chart record of voltage variation which could be interpreted by the operator. The pen recorder available had five channels, from each of which varying voltage could be read off by means of a trace on pre-scaled paper. Each channel had a pen, with an ink reservoir which supplied ink to the pen. The paper speed could be selected from 1,2,5,10,25, 30,125 or 250 mm/s. The pen recorder can be seen in figure 8/6.

The output voltage pulse from a photo cell varied in shape, as well as in size, according to the particular solid initiating the pulse. Although the fact, that pulse size could not be controlled in the 'site' environment, due to varying solid size, meant that an automated velocity measuring system had to be ruled out, this same fact proved invaluable in translating pen recorder chart output. It was discovered that pulses initiated by apparently identical solids, such as sanitary protection products of the same manufacture and type, varied to a degree as regards pulse shape. When considering the multitude of possibilities as regards solid geometry and composition to be found 'on site', it was discovered that each solid could be recognised in its passage past the various photo cells by its particular and distinct pulse size and shape. This meant that more than one solid could be monitored in the same waste pipe at the same time, particularly after gaining some practice at analysing signal output, as only pulses generated from solids were consistent in appearance from one photo cell output to the next, water interference pulses varying from cell to cell. Thus even the small solids, generating voltage pulses smaller than the larger water interference pulses, could be identified.

Having decided that the pen recorder method of interpreting photo cell outputs in the site situation was the only realistic possibility, the shortcomings of the method had to be reconsidered. There were two main sources of inaccuracy, the first and basic source being the 'built in' inaccuracy of the pen recorder gearbox, being a limitation of the equipment about which little could be done. The second source of inaccuracy was the unavoidable error made in measuring linear paper distance between relevant pulses on the chart output. It was considered that a realistic estimate of such an error was in the region of ± 1.0 mm. per measurement. Obviously the error was lessened proportionally as the distance to be measured was increased.

Factors which could be altered to afford an increase in distances to be measured, to reduce this type of error, were the paper speed of the pen recorder and the separation between photo cells. A chart paper speed of 50 mm/s. had been considered realistic when assessing the likely variation in time taken for different discharges to clear the monitored length of pipework, the pulses produced being clear and precise for both fast and slow travelling solids. The next possible paper speed available on the pen recorder was 125 mm/s.. By increasing to this speed the pulses recorded for fast travelling solids became clearer and more obvious, but the slow solid pulses became vague and relatively hard to distinguish. The shear length of paper output generated per recorded discharge became unmanageable at 125 mm/s., it being considerably more difficult to co-ordinate between pulses and to successfully translate the output to meaningful results. Running at the higher speed would, also, have incurred a considerable increase in expense for chart paper provision. It was decided that 50 mm/s. was the only reasonable choice for pen recorder paper speed.

In the laboratory, the photo cell / light source units had been used in pairs, separation between the two photo cells of a pair being 300 mm., each pair providing one 'point velocity'. Having previously decided that nine velocity measuring points were required per monitored length of in situ pipework, this system would have employed 18 photo cell units. Increasing the photo cell separation to 1.0 m., even though this would have meant that 'average velocities' and not 'point velocities' were being measured, would have considerably improved the proportion of error incurred from measuring off from the chart paper output. However, the 1.0 m. photo cell separation provided a second advantage to the monitoring system; by spacing ten photo cells equidistant over nine metres of pipe, using the intermediate eight photo cells to both stop the timing for travel over the previous 1.0 m. length and start timing for travel over the following 1.0 m length, nine velocity measuring points could be achieved. Thus ten photo cells instead of eighteen could provide the required information.

For ease of translation of pen recorder output it was considered an advantage to be able to reduce the number of photo cells employed to a minimum, as is explained later in this section. As increased photo cell separation also reduced the errors incurred from measuring off pen recorder output, it was decided to space photo cells at 1.0 m. intervals.

Increased photo cell separation resulted in the measurement of 'mean velocities' instead of 'point velocities'. These mean velocities were assumed to apply at the mid-points of the measuring ranges. In fact, as solid velocity decreased proportionally to $\sqrt{L/G}$, the mean velocity applied further towards the upstream limit of each measuring range. The $\sqrt{L/G}$ values calculated in association with the measured velocities were therefore somewhat greater than would have been correct. However, this apparent error was reduced at larger values of $\sqrt{L/G}$ as the rate of change of deceleration decreased. Thus errors were at their smallest in the area of most interest on a velocity against $\sqrt{L/G}$ graph; the area of high $\sqrt{L/G}$ values, and low velocities, from which the effective length of waste pipe could be calculated.

The pen recorder available having only five channels capable of receiving photo cell output traces, and it being required that ten photo cells be installed per monitored length of pipework, created a further complication; the adopted monitoring instrumentation had to be able to feed two photo cell outputs to each pen recorder channel. Pre-supposing that such a system could be developed, it was vital that the resulting output traces could still confidently be translated. Although it was anticipated, that multi-solid discharges would result in their being solids spaced widely apart in the length of monitored pipework, it was felt, that if the two photo cells, feeding to a particular pen recorder channel, were positioned as far apart as possible on the discharge pipework, then it would in most cases not result in any significant overlap of solid pulses from the different photo cells. Therefore, numbering the photo cells from one to ten, by their respective increasing distances from the W.C., photo cells 1 and 6 were connected to the same pen recorder channel, as were 2 and 7, 3 and 8, 4 and 9, 5 and 10. This zoning method, of which a sample pen recorder trace is given in Figure 8/7, was to prove successful when put into operation.

Solids to be monitored, under site conditions, varied from those tested in the laboratory in respect of colour.

A photo cell / light source arrangement was required, capable of initiating voltage pulses from non-white solids. The system used in the laboratory, based on a 'negative going' voltage pulse being created on a solid breaking a light beam to a photo cell, was suitable for measuring non-white solids. However, on attempting to develop a system capable of feeding two photo cell outputs to one pen recorder channel, problems were encountered. The two outputs were connected in parallel to a pen recorder channel, but clear and distinct output traces could not be obtained from the resultant feedback. The reason for this difficulty was not obviously apparent. A method could have been developed, based on a manual switching system, to change the connection to the pen recorder channel from one photo cell to another as necessary. Such a system, however, would have required precise timing to assure a successful operation, and it was considered impractical for 'on site' usage. Marriott (1979) devised a method, which relied on the difference between the reflectivities of the pipe and a white solid, for monitoring flows in opaque pipes. The photo cell and light source were located side by side in a 'window' at the top of the pipe. The relatively matt pipe surface reflected little light to the photo cell, but on passage of a white solid there was a considerable increase in light reflected to the photo cell, a corresponding pulse being produced on the chart recorder output trace.

This system produced 'positive going', as opposed to 'negative going', voltage pulses. Westaby (1979) further developed this system, also for use with white solids, connecting many photo cell units together in parallel, and feeding the resultant output to one channel of a pen recorder. As this system could be adapted to combine photo cell outputs, it was considered further.

Some interference was caused, by reflection off the surface of passing water, when the photo cell and light source were positioned at the top of the pipe. When using transparent pipework the method could be adapted to monitor non-white solids, and also to eliminate the aforementioned type of interference, by placing the units adjacent to one another at the invert of the pipe. On passage of a solid, with photo cell and light source now at the pipe invert, light was reflected and refracted to the photo cell along and through the transparent pipe wall. The solid merely acted as a 'mirror backing' to the pipe wall, its colour and reflectivity no longer being of prime importance. The system was, therefore, adopted for use on the in situ installations. It was discovered during initial site testing of this method that, better results were obtained by assuring adequate and black screening, tight up to the underside of the pipe, between photo cell and light source.

To recap, a pen recorder, set with chart paper speed at 50 mm/s., was employed to record solid travel. The photo cell / light source units used, producing 'positive going' voltage pulses, were mounted adjacent to one another at the invert of the pipe. Photo cells were spaced at 1.0 m. intervals along the monitored pipework, and were connected, two per channel in parallel, to the pen recorder.

Photo cell and light source units for the 'site' monitoring system were housed in a common casing, see Figure 8/8, and were mounted onto the pipe, as were all previous photo cell / light source units employed, using Marley JB42 two piece brackets. Each casing contained a 12 V., 2.2 W. bulb in series with a variable resistor, thus allowing for adjustment of brightness as required to obtain the clearest possible output from the respective photo cell.

Initially, light sources were supplied in parallel from one 'ring main' of supply and return, it merely being required, on the addition of an extra light source, to extend from the connections to the previous light source.

It was found in practice, that the light sources were successively dimmer, with increase in distance from the power supply, due to cable resistance losses ($I^2.R$), and so the light sources were divided into two banks of five, each wired as before but supplied separately by heavier duty cable, the final parallel connection being made between the two at the power supply.

It was required, that, if necessary, any four photo cell outputs could be connected to any one photo cell channel, a terminal box being constructed to achieve this. Twenty sockets were provided at the back of the box, having a common 12 V. supply, each of which could connect supply and return to and from any chosen photo cell. The twenty sockets were arranged in five banks having four sockets each. The returns from each socket of a bank of four were connected in parallel to a single socket at the front of the box, thus providing five sockets at the front of the box, corresponding to the number of pen recorder channels available. The returns from these five sockets were combined and connected back to the power supply. Both the pen recorder and the terminal box were earthed to the power supply. In this way any chosen photo cell output could be displayed on any chosen pen recorder channel, a maximum of four outputs being displayed on any one channel at any one time. Although for normal operation only two outputs were required to be displayed per channel, and indeed displaying more than two outputs per channel created problems in translating chart output, it was considered useful, in the event of a fault occurring on one or more channels of the pen recorder, that the remaining channels could cope with the photo cell outputs until repair could be achieved. The terminal box is detailed schematically in Figure 8/9, and illustrated in Figure 8/6.

8.5 Cistern Operation Monitoring.

There were four reasons as outlined below, why it was considered necessary to monitor cistern operation.

- a) One of the limitations of the velocity measuring equipment, resultant from the use of a pen recorder was that it could not be set up in constant operation, but required to be started, and stopped, before, and after, each flush passed through the monitored length of pipework.

Consequently it was essential that the operator were given prior notice of an impending W.C. discharge, thus allowing the equipment to be engaged, and the operator to prepare to record relevant details of flush content and solid transport, before the arrival of a flush to be monitored in the discharge pipework.

- b) As the pipe geometry of the access route to the monitored pipework varied between W.C.s, as did the distances between W.C. and velocity measuring points, in order to allow for meaningful analysis of recorded solid velocity results, it was necessary to identify the W.C. of origin of each monitored flush.
- c) In order to examine system loading and usage patterns, as far as was possible concurrently with monitoring solid transport characteristics, it was considered useful to record the number of operations per W.C. with respect to time.
- d) Although a cistern could be set to discharge the required flush volume, there was the possibility that a cistern be operated prior to it being allowed to completely refill. A method was required of determining that such was the case, allowing the operator to label the associated solid velocity data as inadmissible on the grounds of unknown, but less than intended, flush volume.

In the male facility there were two W.C.s, both of which were to be monitored for solid velocity and cistern operation. In the female facility there were four W.C.s, only two of which were to be monitored for solid velocity. However in order to meet the requirements outlined in c) above, it was decided that all four of the W.C.s in the female facility should be monitored for cistern operation.

Cistern operation monitoring was to be achieved by placing a float switch in each of the relevant cisterns, each switch to remain open only so long as its associated cistern were to contain its full allocation of water. Each switch was to close on operation of the cistern, thus completing a circuit, only re-opening on cistern water level rising to its previous position. Thus one switch operation was to represent one W.C. operation. Each float switch needed to be linked to its own counter, to record the number of operations, and to its own visual alarm, to warn the operator of an impending flow and to identify the W.C. of origin. Two consoles were therefore constructed, to handle two and four float switches respectively, for the male and female facilities. Figure 8/11 schematically outlines the four channel counter console, and figure 8/6 illustrates the two channel, the specification detailed below being applicable to either console.

A 24 V. supply was connected to a socket on the side of the console. One socket for each float switch to be monitored, was provided at the back of the console, all sockets being connected in parallel from the common supply. The return from each float switch socket was connected to its own cumulative counter, each counter having its own light source connected in parallel, each counter display and associated light source being mounted adjacent to one another at the front of the console. The returns from each counter were then connected in parallel and joined to the power supply via the socket on the side of the console. The casing of the console was earthed back to the power supply.

A mounting was fixed inside each cistern to be monitored, positioned so as not to interfere with the cistern operating mechanism, to which a float switch was attached, see Figure 8/10. The mounting was manufactured so as to allow for vertical adjustment between itself and the float switch. Having first set flush volume to the required amount, as detailed in Section 9.5.4, and having allowed the cistern to completely refill, the float switch was repositioned vertically so as to be as high in the cistern as possible while remaining totally immersed with the switch fully open.

On operation of the cistern the switch closed as the water level fell, thus engaging the circuit. On refilling of the cistern the switch disengaged, therefore breaking the circuit, slightly prior to the water level reaching its full height. This was unavoidable as repositioning the float switch any higher in the cistern would have resulted in unwarranted counts being recorded, due to the combined action of reduced rate of increase of water level with vertical oscillation of the switch arm by surface wave action.

The supply and return wires, to and from each float switch, were concealed inside 15 mm. I.D. opaque U.P.V.C. overflow pipework, as illustrated in figure 8/12, so as not to attract unnecessary attention from the system user. This pipework was fixed using standard pipe clips and oboe nails. Holes were drilled through the floor adjacent to the wall in the appropriate positions, through which the overflow pipework was directed to deliver the wiring to the relevant cistern operation monitoring console in the floor void. Care was taken to ensure that holes were only drilled through non-structural infill panels.

8,6 Ancillary Equipment.

Certain additional items of equipment were required to ensure successful adaptation of instrumentation to suit the site environment.

The power supply to the floor voids had been intended to provide for limited space lighting, and to allow for the use of hand tools by workmen. This being the case, a low potential supply had been considered both adequate to requirements and most suitable for safe operation.

It was therefore necessary to install a 110. - 240. V. step up transformer, as the monitoring instrumentation was designed to operate at 240. V.

It was considered desirable, since employing a phototransistor based method of velocity measurement, to reduce interference by keeping space lighting levels to a minimum. Monitoring activities were carried out with the installed lighting arrangement disengaged, there being no significant intrusion of ambient light to the floor voids. However, specific lighting provision was required. A small shielded light source was provided on the instrumentation table, to allow for careful observation of instrument performance and output. A larger shielded inspection lamp, on a travelling cable, was provided to facilitate detailed observation of flush content. It was found that the clearest visibility of pipe content could be obtained by placing the inspection lamp behind the pipe, diametrically opposite the observer.

8.7 Data Handling and Presentation of Results.

For each series of tests the following information was recorded; facility under observation; pipe geometry; pipe gradient; pen recorder paper speed; the number of photo cells; the distance of each photo cell from the centre point of the branch connection to the second W.C.; the distance from the outlet of each W.C. to the centre point of the branch connecting the two.

Data which changed with each successive run were then noted, run by run, namely; W.C. of origin of discharge; run identification number; number of solids involved in flush; relative position, and full visual description of each solid, such as solid material, size and shape, apparent specific gravity, i.e. floating or not floating; solid stoppage position if relevant.

Knowing the distances between photo cells and pen recorder paper speed, by measuring the distances, off from the pen recorder trace out, between pulses registered by each particular solid, the average velocity of each solid between successive photo cells could be calculated.

A six number code was developed, as presented in Figure 8/13, to reduce each solid description to a standard form, translatable at a glance, and manageable to a computer. This was not a six digit code, but a six number code, the highest number possible in the largest descriptive group being 33. An example solid code is given below:

1 / 5 / 2 / 1 / 2 / 0

faecal/4"long/4"diameter/single solid/not floating/not appropriate

If a solid stopped in the discharge pipe, the velocity, at all points downstream of the stoppage, was recorded as zero. Any such zero velocities were considered acceptable data in calculating statistical figures. If any malfunction of the monitoring equipment were detected the complete flush was rejected, no data being recorded for that run. Although statistical analysis of solid stoppage position was undertaken, it was accepted that, as monitored pipe runs were not so long as to assure that all solids were deposited therein, the validity of such analysis was questionable.

All recorded data was punched onto computer cards, as opposed to paper tape as used for laboratory results, see Section 4.8. This was done to facilitate easy comparison of results. It was only required, with results gained in the laboratory, that the data gained using identical test solids, under identical test conditions, be compared to each other.

Thus, all such data could usefully be stored on one reel of tape. However, when considering site results, it was required that the data gained from any one particular solid, in any one particular flush, be compared amongst several groupings of solids. Thus by arranging that all the data concerning a particular solid, and not a particular flush, were stored on its own card, a data-bank of results was set up. On wishing to compare all solids having one particular similarity, the data bank was sifted, and the cards representing all such solids were selected and removed. The selected group of cards were immediately duplicated, and the originals were re-inserted into the data-bank.

The previously outlined input data, in selected groupings, was processed by the computer program 'MASTER GREENWICH'. This program, details of which are presented in Appendix II, was written in Fortran and run on the Brunel University ICL computer. The program 'MASTER GREENWICH', was by and large, simply an adaptation of the program 'MASTER DREG', as used to process laboratory data, and as outlined in Section 4.8 and Appendix I. The adaptation basically involved removal of that part of the program relating to the amount of water discharged ahead of each solid, and extension of the program to allow comprehensive definition of each solid (re. material, shape, size, position in flush, etc.).

For the benefit of any future researcher, who may wish to extend this work, a complete listing of the 'data-bank' of successfully monitored 'live' waste discharges ('faecal' and 'non-faecal' flushes), as recorded for each combination of installation and gradient, is presented in Appendix III.

9. MONITORING OF IN SITU INSTALLATIONS.

9. MONITORING OF IN SITU INSTALLATIONS.

In order to be able to link theoretical analysis, of the forces acting upon a model solid, and laboratory experiments, to the performance of the range of waste solids found in practice, site testing of a 'live' installation was considered essential. It was expected that, due to physical and biological differences between the sexes, solid loading on a male lavatory facility would be heavier than that for an equivalent female facility. Also, the provision and subsequent use of urinals in a male facility must of necessity result in fewer 'water only' flushes of the associated W.C.s, thereby reducing the likelihood of possible solid stoppages in the associated pipework being cleared by normal usage, due to the fact, of an overall reduction in the amount of water passing through the pipework without any reduction in solid loading. It was therefore decided to monitor both a male and a female facility in an in situ environment.

9.1 Choice of Suitable Hospital.

The basic environmental requirements of the chosen location, considered essential to assure successful 'on site' monitoring, were as follows:

- a) A sufficiently high level of facility usage so as to allow for the maximum possible amount of data to be collected in the time available.

As discussed in Section 8.4, it was not possible to automate the monitoring instrumentation, an operator being required to instigate, co-ordinate and control all 'on site' monitoring activities. As a result, it was considered unavoidable that a certain amount of the operators time be lost between, and while awaiting W.C. operations. Under these conditions it was essential that system usage be as high as possible.

- b) The existence of, or the space to replace the existing pipework with, sufficiently long runs of transparent soil pipe prior to connection to any other 'live' pipe or vertical main.

Transparent pipework was required due to the limitations of the monitoring instrumentation, see Section 8.4, and to facilitate visual assessment of system operation. It was required that pipe runs be of comparable length to those tested under laboratory conditions, see Section 4.2.

- c) The space to allow for accurate adjustment of monitored pipe gradient.

Pipe gradient was to be adjusted employing a normal surveyors level, thus requiring intrusion-free vision along the lengths of the monitored pipework.

- d) A building layout suitable to allow for all necessary adjustments to the existing installations, and all subsequent monitoring activities, to remain undetected by the facility user.

As this study was to be conducted in a functioning hospital, it was of paramount importance that there be no intrusion on the daily activities of staff and patients. It was also essential that likely users of the monitored facilities, either in the immediate vicinity of the installation or in the general area, be unaware of any unusual activity, as this could only interfere with normal behavioural patterns as regards lavatory usage.

Various locations were considered, two of which appeared to conform best to the requirements. A Nottingham hospital, having sufficiently large inter-floor voids to allow accommodation for all the necessary activities, was one possible site, part of the internal drainage system here being of transparent glass pipework. The second acceptable location was Greenwich District Hospital, which also had large inter-floor voids, but where the existing internal drainage system was constructed using spun cast iron pipe. Although at Nottingham some transparent pipe had already been installed, the major part of the glass installation had not been commissioned at the time of inspection.

Both hospitals were equally acceptable locations for the proposed experimentation. The final choice of Greenwich District Hospital was made on the grounds of proximity to the base laboratory at Uxbridge, Greenwich being within commutable distance, thus allowing for the laboratory to be employed to provide back up for the installation and maintenance of 'on site' equipment and instrumentation.

9.2 Survey of Hospital Facilities.

Having chosen a suitable hospital at which to monitor in situ facilities, it was then necessary to identify the particular male and female lavatories most suitable to requirements. It was considered inappropriate to monitor installations used solely by patients, as according to the types of wards served, the system loads would not be comparable to those representing normal usage. By selecting facilities used by the general public, members of staff and some ambulatory patients, it was intended that the data collected concerning system loading and usage would be a reflection of what might be expected of any public facility, at least as regards the types and proportions of different loads if not the daily usage patterns.

9.2.1 The Initial Survey.

A particular female installation in the Nurses Education Department was suggested by Hospital Engineering Staff as being likely to have a high and regular usage, there being student nurses attending courses in the immediate vicinity from 8.30 a.m. to 4.30 p.m. throughout the week. The lavatory in question contained four W.C.s. This particular facility was situated above a relatively service-free area of inter-floor void, which would have allowed enormous scope for easy adaptation of the service pipework. However, the fact that the likely users would be largely within a similar age group could have resulted in unrepresentative system loading. Considering just one aspect, as an example, the probability that a particular individual uses tampons as opposed to some other form of sanitary protection product may be dependent to a degree upon that person's age, as might the probability of a person disposing of such products via a W.C., and therefore

the proportions of such products appearing in the drainage system may be affected. However, it was decided to install sections of clear U.P.V.C. pipework into the existing service pipework to this facility, as illustrated in Figure 9/1, sufficient to allow an observer in the floor void to evaluate the system load visually and to identify W.C. of origin for particular discharges. It was intended that this initial survey would evaluate the proportion of W.C. discharges containing waste solids and indicate the general level of usage required to provide an acceptably high rate of data collection.

Observations were conducted from 7.a.m. to 6 p.m. over a three day period, in mid-week, during the month of August 1978. The earliest recorded flush over the period was at 7.59 a.m., the latest being at 4.31 p.m.. The average daily number of W.C. discharges was 32, 22% of which originated from the least used W.C., and 30% of which originated from the most used. Of the observed flushes, 48% contained no solids, 41% contained non-faecal solids only, and only 11% contained any faecal material.

These results confirmed the expectation of a high proportion of water only flushes. The majority of the 'non faecal' solid flushes contained one toilet tissue paper solid only. By monitoring this facility, only 3 or 4 flushes containing any faecal material could have been expected per day, that is only one 'faecal' flush from each of the installed W.C.s. It was necessary, when testing solids manufactured to identical specifications in the laboratory, to perform thirty flushes to provide enough data to calculate an acceptable average transport characteristic. When considering the wide variation in composition of 'faecal flushes' possible 'on site', as regards number, geometry and material of solids, it was obviously apparent that a great many flushes containing faecal material would need to be monitored to allow for definition of solid travel characteristics. Only a small proportion of the required data could have been collected at this installation in the time available, a considerably higher usage being required of the chosen facilities.

9.2.2 The Wider Survey.

By this time, it was clear that the choice of facilities to be monitored would have to be based over-ridingly upon the level of usage, even if this were to result in other relevant requirements not being all that would have been desired. Considering the time taken to organise and install the transparent U.P.V.C. sections into the service pipework to the Nurses Education Department lavatory suite, and having gained from this initial survey some knowledge of the proportions of various types of solid loading on a system, it was decided that a wider survey of facility usage should be carried out simply by counting the number of people entering particular facilities during the course of a day. To put this into practice, an observer was situated inconspicuously at some distance from, but within sight of, the installation under examination. It was envisaged that, once having set up full monitoring activities 'on site', the daily time period available for data collection would be from 8 a.m. to 3 p.m., the compound reasoning for this being discussed in Section 9.5. This being the case, it was decided that the observations of facility usage should be carried out over the same period. Observations over one day per facility were thought sufficient to establish the most used installations. However, in practice it was found that the levels of usage, of several of the facilities, were so low as to eliminate these facilities on only a few hours observation of each.

A male and a female installation were finally chosen, both serving the same Cafeteria / Reception / Circulatory area, as these were visited by a great many more people daily than any of the other facilities, at least over the time period in question, both serving in the order of 170 people each per day between 8 a.m. and 3 p.m.. These data, having been collected over a very limited time, were only employed as an indication of level of system usage, and could not be regarded as reliable average usage data.

Fortunately, the inter-floor voids below the chosen laboratories did provide reasonable accommodation to allow for the required system adaptations and monitoring activities, the problems which were encountered being outlined in Section 9.4.

9.3 Facilities Chosen for Full Monitoring Program.

9.3.1 The Area Serviced.

As previously stated, the facilities finally decided upon as most suitable for an in depth study, though not immediately adjacent to one another, both serviced the same area. The area in question, a detailed plan of which is illustrated in Figure 9/2, though in actuality one space, was divided, insofar as usage was concerned, into two basic areas. The first area consisted largely of circulatory space, allowing access between the main ground floor entrance, the escalators to all other floors, and adjoining corridors to all other departments on the ground floor. This area, a general view of which is presented in Figure 9/20, contained a reception desk, being continually manned, provided access to the service windows of an adjacent pharmaceutical dispensary and a W.R.V.S. shop, and was also used as a general waiting area having a seating capacity of approximately sixty. The second area, a general view of which is presented in Figure 9/19, was employed as a self-service cafeteria, having dining accommodation for approximately ninety-six people, and being open daily from 9 a.m. to 4 p.m., including weekends. Of the people observed, making use both of the cafeteria and the general area, there appeared to be roughly equal numbers of the general public and hospital staff. The members of the general public were of all ages, possibly being outpatients or visitors, and the members of hospital staff being easily recognisable by their manner of dress, were by and large kitchen staff, cleaners, porters, engineers, technicians, nurses and ambulance men. The third, and by far the smallest, visibly distinguishable group using the area were ambulatory inpatients.

9.3.2 Sanitary Services Provided.

Figures 9/3 and 9/4 illustrate the floor plans and installed services for the female and male facilities respectively. The female facility, a general view of which is presented in Figure 9/17, contained four W.C.s and two washbasins. The male facility, a general view of which is presented in Figure 9/18, contained two W.C.s, two urinals, and two washbasins. All of the installed W.C.s were un-vented Armitage Shanks V1207 S-trap, 'top inlet', washdown pans, as shown in Figure 9/5, and having solid ring seats. The flushing cisterns were of the piston variety, also being of the water saving short / long flush type, which had been adapted prior to this survey to deliver full flush only. The cisterns delivered via 38 mm. (1½") internal diameter flush pipes, and were mounted 1.145 m. above finished floor level (f.f.l.), therefore being considered as medium level. Figure 9/6 illustrates the W.C./cistern configuration. The urinals were of the individual bowl type, see Figure 9/7, each being close-coupled to, and contained within the same vitreous china housing with, its own automatic flushing cistern. The urinals were spaced at 640 mm. centres, and were not individually screened. The water supply rates to the two urinals were extremely disproportionate, one urinal flushing to requirements at approximately twenty minute intervals, the second flushing only at intervals of several hours, the consequence of its water supply rate being considerably less than required. Each W.C. was positioned within its own compartment, partitions not being fully from floor to ceiling, but being of the type to allow aerial connection between each cubicle and the remainder of the facility space. In the female installation, W.C.4 was designated an 'invalid' facility, see Figures 9/3 and 9/17, its associated cubicle providing generous accommodation with easy access. Two hand towel dispensers, normally containing 'Kleenex Soft Blue Handtowels', and a large bin for the disposal of the same, were provided in each facility. In addition, in the female lavatory, each cubicle was provided with a supply of sanitary towel bags and a pedal bin. The toilet tissue paper provided throughout was of the greaseproof type.

9.3.3 Peculiarities of Facility Usage.

The male facility was closed for a 42 hour period each weekend, from 12 noon on Saturday until approximately 6 a.m. on the following Monday morning. This procedure came into operation, prior to this study, due to the unacceptable level of vandalism to the installation experienced repeatedly during the period specified. Cleaning operations were carried out in this facility at approximately 7 a.m. each morning, excluding Sundays, these procedures being performed in an identical manner on each occasion. Each W.C. was flushed in turn, both before and after being cleaned, a bucket of water being disposed of via W.C.5, and that pan again being flushed, after the remainder of the facility had been dealt with. The female facility was not closed at any time, but was subject to similar cleaning operations each morning, including Sundays, the pan receiving the extra flush and bucket of water in this case being W.C.3. To recap, then, cleaning operations accounted for two flushes each of W.C.s 1,2,4 and 6, and three flushes each of W.C.s 3 and 5, for each day of the week as regards W.C.s 1,2,3, and 4, and excluding Sundays for W.C.s 5 and 6. This information was required so as to enable the data collected, concerning frequency of W.C. operations, to be adjusted as necessary to determine user operations.

9.3.4 Regulatory Assessment of Facilities.

Neither of the facilities were adjacent to any external wall, and there was therefore no possibility of natural ventilation. The Building Regulations, England and Wales (1972), require that such being the case, mechanical means of ventilation, effecting not less than three air changes per hour, and discharging directly into the external air, must be provided. Extract grilles were in evidence in each facility, and were observed to be in continuous operation.

The Byelaws of the Greater London Council require that no W.C.;

"be situated within, nor entered from, any room used for..... sale of food or drink for man".

It is required that an entrance lobby be provided in such a case, the lobby being constructed so as;

"to secure aerial disconnection between such water closet and any room specified.....and such lobby shall be provided with close-fitting and self-closing doors".

Neither of the facilities in question were provided with any entrance lobby, both opening directly into the area specified. This was possibly due to the fact that Crown Properties are exempted from all statutory regulations. Automatic door closers were provided, but did not function satisfactorily, the closing actions being relatively slow, and the doors not closing completely without assistance. Screening in the female facility interrupted the visual line between the facility and the area serviced reasonably adequately. This facility, opening into a circulatory part of the area in question, and being at some distance from the dining section of the area, was considered acceptable. Due to insufficient screening, visibility from the cafeteria area into the male facility was unavoidable. As there were dining tables within two metres of the entrance to the male facility, and having regard to the lack of a suitable lobby this arrangement was considered inadequate as regards both hygiene and social acceptability, and this would still have been the conclusion had adequate screening been provided.

9.3.5 Scales of Provision of Sanitary Appliances.

As previously stated, a considerable amount of data was to be collected concerning the levels of usage of the monitored facilities, and it was intended to attempt to assess, from these data, the degrees of success displayed by the facilities in coping with demand. In order to achieve this, it was necessary first to assess the original design estimation of area population, and to re-assess the validity of this estimate from present day observations of area population, as the number of possible facility users is the base from which the numbers of particular sanitary appliances required are decided upon. The scales of provision of sanitary appliances may be subject to statutory and / or authoritative regulations, depending upon the particular premises under consideration and its required usage.

However, as already mentioned, Crown Properties are exempted from all such regulations, but it was considered reasonable to assume that the relevant regulations were employed as a guide.

The Hospital Building Notes (as available from H.M.S.O.), recommend levels of provision of sanitary appliances for specified hospital locations, but none of the areas dealt with could be considered to reflect this particular location. The only area covered, which could in any way be taken to correspond to the area studied, is classified as waiting space. By this standard, the level of sanitary provision in the male and female facilities suggests a design population of 60 males and 120 females. Since it could only have been assumed that, in the area under consideration, there would be equal numbers of males and females, this standard could not have been the criteria by which levels of sanitary provision were calculated.

According to C.P.3 (1950) as regards restaurants, the Greater London Council 'Places of Public Entertainment Technical Regulations' as regards restaurants and public houses, the Public Health Acts, of 1936 and 1961, as regards,

"any building in which food or drink is sold to and consumed by the public",

and C.P.305(1974) as regards restaurants public houses and canteens, the provision of two male and four female W.C.s suggests a population of 101 - 200 of each sex. From observations it was considered that an area population of over 200 people was, on occasion, a definite possibility, but that it would be highly unlikely to ever reach 400 persons. The level of W.C. provision then, seemed suitable to requirements, and according to the relevant regulations, even to have some spare capacity. A design population of 202 - 400 persons, there being equal numbers of males and females, was accepted as realistic. However, it was not forgotten that the area under consideration was not an isolated unit, but merely a small part of an extremely large multi-purpose building. The proximity of various other departments, along with the location and number of other sanitary services provided in those departments, were contributory factors affecting a degree of interaction of area populations as regards lavatory usage.

By all of the previously mentioned regulations , (C.P.3(1950), the G.L.C. Technical Regulations, the Public Health Acts (1936 and 1961) and C.P.305.(1974)),urinal provision is recommended at the rate of one per 25 males. Considering that only two urinals were provided, and that the estimated area population included 101 - 200 males, according to accepted standards the level of provision of urinals was inadequate. In calculating the corresponding number of washbasins required, the regulations are not in agreement. Code of Practice C.P.3 (1950), recommends from 5 to 7 washbasins for each of the male and female facilities, depending on whether each facility population be nearer 101 or 200 persons. However,C.P. 305 (1974) recommends only two washbasins for the female facility, this being based upon the number of W.C.s provided, and suggests for the male facility one washbasin per W.C., plus one extra washbasin for each five installed urinals. If the numberof urinals provided had been according to recommended levels this would suggest that four washbasins should have been provided in the male facility, whereas according to existing levels of urinal provision, three washbasins should have been provided.

According to accepted standards, then, and based upon adequate W.C. provision for the estimated population, there appears to have been inadequate provision of urinals and washbasins in the male facility. The adequacy of provision of washbasins in the female facility is open to some question, the regulations not being in complete agreement. Having, thus, attempted to evaluate the levels of provision of sanitary services in terms of regulatory requirements, it was intended that the validity and suitability of such regulations be evaluated from observations and measurements of facility and W.C. usage patterns collected during the proposed monitoring procedures.

9.4 Installation of U.P.V.C. Pipework and Monitoring Equipment.

Figures 9/8 and 9/9 detail, respectively, the routes of the sanitation services to the monitored facilities as originally installed, and as subsequently adapted for this study.

9.4.1 Standard of Workmanship.

Having observed plumbers installing U.P.V.C. pipework, under site conditions, it had been concluded that insufficient care and attention was not uncommon in the construction of pipe joints. From laboratory experiment it was abundantly clear that bad jointing was a direct cause of premature waste solid deposition. Pipes cut to length on site are required to be cut squarely, the cut spigot ends being chamfered and smoothed so as to eliminate unnecessary restriction to waste flow. To this end, also, socket penetration requires to be at a maximum, the insertion depth being that which allows 10 mm. only between the pipe and the bottom of the socket, this being required for expansion purposes.

It was considered doubly important that pipe joints be adequately made, as the installations to be constructed were to be tested at particularly flat gradients. It was, thus equally essential that the pipe gradients themselves be accurately set up, as described in section 8.2, by precise and careful adjustment. All pipework was therefore constructed and installed with assistance from laboratory technician staff only, hospital plumbers being employed to cut away previously existing C.I. pipework.

9.4.2 Method of Installation.

It was intended that interference to the normal working of the hospital be avoided as far as was reasonably possible. To this end, it was required that the male and female facilities be closed to the public, during alterations to the service pipework, for as short a period as possible. The method of installation, of the new U.P.V.C. service pipework, was organised so as to achieve this.

The hospital plumbers were called in, for each facility in turn, to cut into the main C.I. soilpipe at the required position, and to insert a Glynwed GTO6 135° branch, as shown in Figure 8/4 and discussed in Section 8.1, the branch connection then being temporarily capped off. In order to achieve this it was necessary to arrange that all facilities, discharging into the relevant main soil pipe upstream of the particular branch connection point, be closed down for approximately a half an hour. However, in practice, and possibly due to the 'hospital' nature of the sanitary services involved, this proved to be unobtainable, discharges arriving through the main during procedures to install the new junctions. Precautions had been taken for such an eventuality, but these rogue discharges considerably hampered operations. The U.P.V.C. service systems were then constructed and installed, backwards from their respective junctions, each installed length of pipe being temporarily capped off until the next length was ready to be connected. Details of the fittings used, to achieve satisfactory construction, are given in Section 8.1. Each system having been installed to within a few feet of the relevant W.C.s, the male and female facilities were closed down, each in turn for approximately a half an hour, while the existing C.I. service pipes were cut away, and the newly constructed U.P.V.C. systems were connected.

The proposed pipe routes had to be adjusted to the particular site situations, the proximity of such obstructions as structural beams and columns, other building service systems, and 'void' access routes having to be taken into account. On routing the transparent U.P.V.C. pipe through particularly dense areas, it was essential that there be sufficient accommodation, above and below the installed pipework, to allow for the adjustment of gradient required. Figure 9/10 illustrates one such area, through which the service soilpipe from the female facility had to pass. Some problems were encountered when attempting to install the frames, described in Section 8.2, from which the U.P.V.C. pipework was to be suspended. It proved impractical to preconstruct these frames in total, as had been intended, as they often had to be installed amid, and around, existing services. Two such support frames can be seen in Figure 9/11.

It was found that a frame could best be installed, in a difficult location, by first positioning the pre-constructed vertical legs separately and independently, then cutting to length and fixing a suitable horizontal connecting bar, the four 'adjustable feet' lastly being extended to firmly wedge the frame in position.

The introduction of waste flows into the monitored pipework, from urinals or basins, could only have served to confuse the issue of waste solid transport, such flows being unknown and random variables. As it was required to examine the 'worst possible case' situation, and as the introduction of such urinal or washbasin outflows could only have improved waste solid transport, it was decided to leave these wastes connected into the existing C.I. soil system. To avoid having to cut away and re-route these waste pipes, the existing 100 mm. I.D. C.I. soil pipes, serving the W.C.s chosen to be re-routed, could only be cut back as far as the point of connection of the first such pipe. The U.P.V.C. pipework had to be routed, as illustrated in Figure 9/11, so as to avoid these remaining service pipes.

The monitoring instrumentation was installed without particular difficulty. The holes through the floor, from the monitored facilities into the floor void, through which it was required to pass the wiring to the cistern float switches, as discussed in Section 8.5, were drilled out by the hospital engineering staff. The holes were placed so as to be as close to the W.C.s and as unobtrusive as possible, the only constraint to positioning being the avoidance of structural members. The facilities were closed down, each in turn for a short period, while these holes were drilled float switches were fixed inside the cisterns, the overflow pipework to conceal the wiring was cut to fit and fixed in place, and the wiring was connected up and threaded through the relevant pipework to thus pass into the void. Figure 8/12 illustrates one such completed arrangement.

9.4.3 Effects of Limited Space.

As outlined, due to the particular restrictions encountered on site, the proposed transparent U.P.V.C. services had to be adapted during installation. The problems encountered were successfully overcome, as regards the pipework constructed to serve the female facility, a totally acceptable pipe route being achieved. Figure 9/12 shows the longest section, which could be viewed from one location, of the completed U.P.V.C. service to the female facility. However, as regards the male facility, the 'on site' difficulties were less easily dealt with. The accommodation required could simply not be found, despite much consideration, sufficient to allow a service system to be installed of comparable straight length to that constructed for the female facility. It was, therefore, necessary to incorporate a bend into the service pipework. It had been intended to investigate the effect of bends in a 'live' installation, but it would have been preferred that this be dealt with separately. The choice of facilities to be monitored had been based over-ridingly on level of system usage, as discussed in Section 8.2, and another male facility receiving sufficiently high usage was not available. The best possible use had to be made of the difficult environment encountered. The congested nature of the space available is illustrated in Figures 9/11 and 9/13, which each show a part of the installed U.P.V.C. service to the male facility.

Two extract ducts dropped into the floor void between the outlets from the two male W.C.s. No matter which, of the two W.C.s, were to be connected to the straight length of U.P.V.C. discharge pipe, the connecting branch from the second W.C. had to pass between these two ducts. No pipe route could be arranged to allow for an unobstructed branch connection at the 135° angle required, the extract duct seen nearest the camera in Figure 8/2 being the offending obstruction. It was not possible to arrange for this duct to be re-positioned.

The connecting branch had to pass to the side of the duct, at an approximate angle of 122° to the main straight length of U.P.V.C. discharge pipe, an adjustable bend being employed to align to the 135° branch connection. This arrangement is detailed concisely in Figure 9/14, the configuration adopted at the equivalent junction on the female facility being presented in Figure 9/15 for comparison.

9.5 Monitoring Procedures and Operating Difficulties.

It was necessary, before monitoring could be initiated, to accurately adjust the lengths of U.P.V.C. pipework to the gradient required for the particular series of tests. The method by which this was achieved is outlined in Section 8.2. It was also necessary to adjust each cistern, discharging into the monitored pipework, to the desired flush volume. Section 9.5.4 details this procedure.

9.5.1 Daily Monitoring Period

The Cafeteria, in the area served by the facilities under observation, was open daily from 9 a.m. until 4 p.m.. It was therefore decided that this would be the best period during which to carry out monitoring activities, having in mind the collection of the maximum possible data in the time available. However, there were other factors influencing this decision. Investigation of the viability of daily travel, to and from the site, via public transport, suggested that the time involved would have been excessive. Various items of equipment, from the base laboratory, needed to be transported to the site as and when required. Items of instrumentation, normally installed on site, had on occasion to be returned to the laboratory for repair. Having considered these facts, it was decided that private transport was the only feasible travel medium. By staggering the time spent on site to avoid 'rush hour' traffic, it was possible, firstly to keep travel times to a minimum, and secondly to return to the base laboratory each day, prior to its closure, to prepare for the following day on site. Thus, monitoring was carried out between 8 a.m. and 3 p.m. daily, this period having been decided upon as much by force of circumstance as by choice.

9.5.2 Regulations Concerning Floor Void Working.

It was discovered, at the outset of 'on site' operations, that the hospital working regulations required that no man work alone in the hospital floor voids. It was extremely difficult to manouvre from one area of the floor voids to another, due to the multitude of building service systems housed therein. Some areas of the voids were on relatively busy access routes, but others were extremely isolated and seldom visited. Thus the likelihood of a workman being quickly discovered, on having suffered illness or injury while in the voids, was extremely poor. It was with these facts in mind that the 'two man working' rule was enforced. It had been intended that one operator only perform all the necessary activities, and the need to employ a technician assistant, throughout all 'on site' monitoring, was considered an added complication. However, once having initiated site experiment the assistant was usefully employed, it being discovered that one man could not satisfactorily perform all the required operations alone.

The second rule governing floor void working was that void passes were required. Such a pass had to be applied for, at the Works Department, on arrival at the site each morning. On leaving the site at the end of a day, the void pass had to be returned to the Works Department. This rule was intended partly to assure floor void security, and partly for safety reasons. By registering all passes issued, in the manner described, the Hospital Engineer could check floor void occupancy, as required, in case of fire.

9.5.3 Void Security.

On having obtained a pass for the day, it was necessary to enlist the assistance of a member of the hospital engineering staff to unlock the door to the appropriate service shaft, thus allowing admittance to the voids. All void access doors were self closing, and self-locking on closure, keys being issued to certain grades of hospital maintenance staff only.

All valuable items of instrumentation, under advice from the Hospital Engineer, were stored in specially provided security lockers at the end of each day's testing. This presented no particular problem, excepting that extra time had to be allowed, before and after the required daily monitoring period, to assemble and dismantle the instrumentation.

9.5.4 Setting Cistern Discharge Volumes.

Normally it is required, by regulation, that the discharging or flushing capacity of a cistern shall be not less than 9.1 litres of water. In practice this usually results in the actual water storage capacity of a cistern being set to 9.1 litres, and consequently the flushing capacity, depending upon the pressure of water and the size of the supply pipe, is as much as 10. or 11. litres. However, for this study it was intended that the actual discharge be 9.1 litres, thus conforming to the 'worst possible case' approach. The method, by which cistern discharge capacity was adjusted to requirements, is outlined below.

An inflatable drain plug, connected to an ordinary bicycle pump by a length of rubber tube, was placed down into the trap of the W.C.. The plug was then inflated to totally seal the trap, and the contents of a measuring cylinder, holding exactly 9.1 litres of water, was carefully emptied into the W.C. pan. The inside of the pan was then marked carefully, at several points around the circumference, exactly at the level of the water line. The drain plug was then removed, and the whole procedure repeated twice more to ensure that the bowl had been marked correctly. This having been done, the drain plug was again inserted and inflated, and the cistern was flushed. The resultant water level inside the bowl was noted in comparison to the previously marked level, and according to the degree of divergence between the two, the ball valve in the cistern was adjusted as necessary. This procedure was repeated until the cistern discharge water level, inside the W.C. pan, consistently coincided with the previously marked level. Particular care was taken, on inserting the inflatable drain plug into the trap of the W.C., to ensure that the trap water level was disturbed as little as possible.

Obviously, on insertion of the plug, trap water was displaced, in proportion to the volume of the plug, and was dropped out over the back of the trap. However, by ensuring that the plug was totally deflated, and did not at any time, during it's placement, become a 'full bore' obstruction, no discernible alteration in trap water level occurred. A limited rise in trap water level may have occurred during inflation of the plug, but due to the repeatable manner in which the plug was inserted on each occasion, a consistent trap water level, prior to each measurement, was assured.

This method was employed, after initiation of monitoring activities, to periodically check the discharge volumes from the relative cisterns, and was developed so as to avoid the possible health hazard involved in having to continually break into the discharge pipework to take these same measurements. However, having set cistern volumes by the previously outlined method, and in order to double check that the method was accurate, cistern discharges were caught and measured, by breaking into the discharge pipework, on one occasion at the outset of 'on-site' activities. This check confirmed that the method developed was indeed accurate, which method was therefore adopted for the duration of 'on site' activities.

9.5.5 Cistern Operation Monitoring

Having, thus, assured that pipe gradients and cistern flush volumes had been satisfactorily adjusted to requirements, monitoring activities were initiated. The counter clocks on the cistern operation monitoring consoles, as described in section 8.5, were set to zero, and the consoles were then activated, the exact time and date being simultaneously recorded. These consoles remained in continuous operation, 24 hours a day and 7 days a week, for the remainder of the study period. On each of the days when waste solid velocity monitoring was undertaken, and throughout the study period of from 8 a.m. to 3 p.m., the number of cistern operations for each W.C., recorded by the counter clocks, were noted at half hourly intervals, as was the date and day of the week on which these results were obtained. At all times, when no operator was present on site, it

was necessary to secure the cistern monitoring consoles in the lockers provided. Notches were cut into the locker lids, to allow passage of wiring as required from the power supply and float switches, so as not to necessitate disconnection of the consoles at any time. To ensure that no overheating could occur of the transformers, associated with the consoles and reducing the supply from 240.V, to 24. V. as required, ventilation holes were also drilled into the locker lids. The consoles were removed from the lockers, during solid velocity monitoring periods, and placed so as to be easily visible to the operator, thus ensuring that cistern operation warning lights were not overlooked.

9.5.6 Waste Solid Velocity Monitoring

The instrumentation employed, during waste solid velocity monitoring, is outlined in section 8.4. On having gained access to the voids at the start of a day on site, and having assembled the instrumentation, the power supplies to the photocells and light sources were engaged, slightly before 8 a.m., and were not disengaged until the end of the monitoring period. No other action was taken until one of the cistern operation warning lights indicated an impending flush, at which time the pen recorder was switched on. As the discharge proceeded through the monitored length of pipework, the passage of any waste solids therein, past each photocell, was automatically registered on the pen-recorder trace out. During this process it was necessary to ensure that all photocells and pen-recorder pens were functioning correctly, that an operator continually watch the operation of the pen-recorder. The pens were liable to blockage, partly due to the long periods between usage, and were a continual source of aggravation. If just one pen ceased to function, even momentarily, this rendered the complete trace out, recorded for that particular flush, untranslatable and therefore invalid. However, if ink was pumped manually, immediately upon a pen's failure to perform, a valid trace out could still be achieved. From the moment the discharge entered the monitored pipework, until the pen-recorder was switched off, the second operator carefully observed the flush for details of waste solid content.

On all solids, involved in the discharge, having either cleared the length of monitored pipework, or been deposited prior to the possibility of clearance, the first operator was informed of the fact and the pen recorder was disengaged. The pen recorder was disengaged, if in the discharge under observation there were no solids, as soon as this fact became apparent.

The start and finish points for each discharge were marked on the pen recorder trace out, as was the allocated run identification number. The following details were recorded in the site survey notebook, under the heading of the same run number: the W.C. of origin of the discharge; the number of solids involved; a complete description of each solid, from visual observation, such as material, geometry, and apparent specific gravity, i.e. floating or not floating; stoppage position of any solids deposited. Any special or unusual details observed were also recorded. The operator, stationed at the instrumentation table, had continually to be aware of the cistern operation warning lights, so as to initiate monitoring as required, and so as to be aware of any overlap of discharges in the monitored pipework.

9.5.7 Instrumentation Difficulties

A second difficulty experienced with the pen recorder, the first being that of pen blockage discussed in Section 9.5.6, was that the re-wound spool of used trace paper was never rolled as tightly as the original roll. Complete paper rolls, and not part rolls, needed to be re-wound. The pen recorder could not satisfactorily house a large re-wound roll. This continually resulted in disturbance to the smooth running of the chart paper, and to solve this problem once and for all, it was decided to rewind all pen recorder output manually.

Apart from such minor, but irritating, obstructions to smooth running, intermittent breakdowns of the instrumentation system were also experienced.

The only real difficulty, on failure of a particular photo cell / light source channel, was in pinpointing the fault, each link in the channel having to be isolated and tested. However, some faults resulted in more extensive system failure. A reasonably comprehensive range, of those parts considered liable to failure, was kept on hand at all times. If a fault could not be isolated more precisely than just to a particular instrument, or if a fault could be isolated but the required replacement part was not available on site, it then became necessary to return to the base laboratory for assistance.

9.5.8 Problems of Cistern Operation and Usage.

It was extremely important that no significant variation in cistern discharge volumes be allowed to occur. As it had been found that, over a period of some weeks, some variation did occur, flush volumes were checked at regular intervals, and re-adjusted as and when necessary by the method outlined in Section 9.5.4. The variations observed may have been due, partly to changes in cistern water supply pressure, and partly to human interference, but the main cause was an inadequacy in cistern design. The vertical stand of water supply to the valve, inside the cistern, was not sufficiently rigid. This stand tended to warp or bend, thus altering the ball adjustment.

Cistern operation warning lights normally remained on for approximately 90 seconds after cistern operation. On one occasion, it was noticed that a particular warning light remained on for a considerably longer period. On inspection of the facility concerned, which was the male, it was discovered that the water supply to each of the sanitary appliances was greatly reduced, water being delivered in intermittent bursts. This phenomenon, obviously caused by some obstruction, continued for approximately a half an hour, during which time monitoring activities were suspended. This was necessary as the low supply rate would have adversely affected cistern discharge volumes.

The cisterns provided in the monitored facilities, as mentioned in Section 9.3.2, were of the dual flush type. Conversion, to full flush delivery only, had been carried out prior to this survey. However, the dual flush instructions, which read 'short flush press and let go, full flush press and hold', were still displayed on each cistern. The dual flush cistern is dependent for its operation on the presence of an air vent at the top of the piston housing. The piston is held at the top of its cylinder, when the cistern lever is held down, the air vent is thus sealed by the piston and a full flush is delivered. If the piston is not held up, when the cistern water has dropped to the level of the air vent, air enters through the vent breaking the siphon and resulting in a short flush. Figure 9/16 details a dual flush cistern. Adaptation, to deliver full flush only, had been achieved simply by sealing the air vent to each cistern. Nonetheless, on several occasions during this survey, one or other of the cisterns reverted to dual flush operation. Such occurrence was obviously apparent from observations of W.C. discharge, and the appropriate remedial action was taken. However, on one occasion repair was postponed for two hours while observations were made of the relevant discharges. All flushes during that period were 'short flushes', irrespective of waste solid content. It was concluded that, either all system users were aware of the supposed conversion to 'full flush', only, which is extremely unlikely, or that misuse of 'dual flush' cisterns is widespread.

There were two other problems concerning cistern operation monitoring. Firstly, on occasion, a W.C. was flushed prior to the cistern being allowed to refill. That this had occurred was apparent, provided an operator was present on site, as a second discharge arrived in the pipework prior to the relevant cistern operation warning light being extinguished. Unfortunately such a flush could not be detected by the cistern float switch, and therefore the monitoring equipment tended to underestimate the number of cistern operations.

The second problem was that, on occasion, and due to wave action in the cistern, a float switch would oscillate vertically immediately after having opened its circuit, thereby closing and re-opening its circuit unnecessarily. Such action resulted in an extra, and non-existent, flush being counted, and thus the instrumentation tended to overestimate the number of cistern operations. It is clear that the method of monitoring cistern operations was subject to some error. However, such occurrences as have been described were by no means frequent, and as the first action caused underestimation, and the second overestimation, the two tend to cancel out.

9.5.9 Human Interference.

Human interference to monitoring activities may be divided into two classes, unavoidable and unintentional disturbances due to hospital maintenance work, and intentional and purposeful vandalism.

The U.P.V.C. pipework, constructed to serve the male facility, had unavoidably to pass over a busy void access route. This resulted in photo cells being knocked, and instrumentation cables being pulled out or broken, as workmen moving along the access route had to duck beneath the pipework. Hospital maintenance staff, on occasion, required to work in close proximity to the monitored pipework. To facilitate this, area space lighting needed to be switched on. To reduce interference to the solid velocity monitoring equipment, as discussed in Section 8.6, it was normally required that space lighting be disengaged. Thus, during such other void activities, monitoring procedures had to be postponed.

As explained in Section 9.3.3, due to the unacceptable level of vandalism experienced prior to this survey, the male facility was closed for a 42 hour period each weekend. Vandalism was not limited either to this facility, or to the period mentioned, but large scale destruction was limited to the male facility. The male facility suffered considerable damage, on one occasion during this survey, when the trap of one washbasin was removed by force, and the greater part of the facility partitioning was pulled down. The facility was closed to the public, for over three weeks, while the appropriate remedial action was taken.

The concealed wires in the female facility, from the cistern float switches to below floor as described in Section 8.5, were frequently interfered with. Cables were broken, on several occasions, thereby causing cistern operation counters to cease functioning. In this way a certain amount of facility usage data was lost. Counters were left in operation, for long periods, during which time no operator visited the site. When damage occurred during such a period, the resultant loss of data was not inconsiderable. It is interesting to note, that no vandalism of this nature was experienced with the male facility.

There was, also, a certain amount of trivial vandalism. For instance, all of the cistern lids, in both the male and female facilities, were completely covered with cigarette burns.

The question arises as to whether any other instrumentation system might better have avoided the vandalism outlined, but given the prevailing environment, the desire for 'non-interference' to normal hospital routine (i.e. no major adjustments to facilities), and the natural curiosity of idle minds (during cubicle occupation), no significant improvement could be devised.

10. DISCUSSION OF 'SITE-WORK' RESULTS.

10. DISCUSSION OF 'SITE-WORK' RESULTS.

10.1 Facility Usage Patterns.

Facility usage was evaluated, as far as possible using the data available, in order to promote a better understanding of the observed waste flows.

10.1.1 The Female Facility.

As mentioned in Section 9.5.9, due to vandalism to concealed wiring in the female facility, cistern operation monitoring was interrupted on several occasions. As the exact times of such interference, being the times at which the counter clocks stopped, could not be known, all data recorded, since the previous reading of counter clocks, were lost. However, uninterrupted data was collected over 26 complete weeks, thus the figure of 2,174.6 W.C. operations in total per average week was obtained. Apart from these data obtained over a considerable period, as half hourly readings were taken of cistern operation counters during 'on site' solid velocity monitoring, a considerable amount of short term data was also available. This data was reduced to average half-hourly usage figures, for each W.C., for the period between 8 a.m. and 3 p.m. for each weekday.

10.1.1.1 Average Usage During 'On Site' Periods.

Figure 10/1 illustrates the average half-hourly combined usage, of all 4 W.C.s, for the average weekday. From this it can be seen, that a morning peak usage occurred at, or, slightly before, 11 a.m., there being a lull between noon and 12.30 p.m., and an afternoon and daily peak at, or, about 2.30 p.m.. It must be stressed that this data applies for the average weekday, and not for weekend usage. Apart from flushes originating from cleaning operations, as detailed in Section 9.3.3, usage prior to 8 a.m. was virtually non-existent. Although no regular observations were made after 3 p.m., from the few days on which observations were continued beyond this time, it was clear that usage levels were reducing, confirming that approximately 2.30 p.m. was indeed a peak.

10.1.1.2 Comparative Usage of Individual W.C.s.

Usage varied somewhat, from the average pattern presented in Figure 10/1, according to the particular day of the week, and there was also some variation for individual W.C.s. Figure 10/2 presents the average half-hourly usage data, in such a way as to allow scrutiny in respect of comparative W.C. usage, and Figure 10/3 illustrates this data, for an average weekday, graphically. Figure 10/4 includes details of the percentages of total usage received by particular W.C.s, based upon the overall 26 week data, compared to similar figures originating from the average half-hourly usage data, and Figure 10/5 presents this same data graphically.

Obviously the different W.C.s received different proportions of usage. As the sample size, of the 26 week 'around the clock' data, was sufficiently large, the differences in usage were indeed significant. However, the half-hourly data was compiled over a much shorter period, approximately 28 periods on site (each of 7 hours duration), in the case of the female facility. Thus, there was some question as to the statistical validity of this data. Unfortunately, an added complication to this question was, that the periods spent on site were not equally spaced over the days of the week. It was not possible to arrange to visit the site as and when required, the over-riding complication being the availability of a technician assistant. More data was therefore collected on Tuesdays, and less on Wednesdays, the remaining site time being equally split over the other three weekdays. None the less, from Figures 10/4 and 10/5, it can be seen that, although not in complete agreement, even the average Wednesday 8 a.m. to 3 p.m. data basically reflects the more reliable data concerning proportional usage between W.C.s.

It can be seen, from Figures 10/2 and 10/3, that although the proportions of usage received by individual W.C.s varied, all the W.C.s conformed within limits, to the basic pattern of overall usage as illustrated in Figure 10/1, W.C.4 diverging most from the 'norm'. Figures 10/4 and 10/5 clearly show, that W.C.3 received by far the highest proportion of total usage, that W.C.2 received the next highest proportion, and that W.C.4 was the least used. However, from the 8 a.m. to 3 p.m. data, averaged for a normal weekday, it appears that, during 'on site' monitoring periods, usage of W.C.s 3 and 4 was roughly equal.

These variations in W.C. usage were thought to be due to a combination of room layout, ease of access to cubicles, the general level of hygiene in any particular cubicle at any particular time, and individual and personal behavioural idiosyncrasies. Fortunately W.C.2 and W.C.3, which had been selected and re-routed for solid velocity monitoring, were the two appliances which received the highest proportions of usage. It is noteworthy, that W.C.4, having an extra-large cubicle in order to accommodate the disabled, was the least used overall. It had been thought, that the extra accommodation, provided here, would be viewed as preferential by ordinary users, and not just the disabled, but obviously this was not the case. However, as previously stated, usage of W.C.4 did vary somewhat from the normal pattern. Consider the following proportions of usage received by W.C.4 during particular periods;

Over 26 weeks 'around the clock'	20.7%
Between 8 a.m. and 3 p.m., per average weekday	23.0%
Over the average weekday peak, between 2 p.m. and 3 p.m.	20.5%
Over the average morning peak, between 10.30 a.m. and 11.30 a.m.	23.3%
Over the average noon lull, between noon and 12.30 p.m.	24.3%

The first two figures seem to suggest, that W.C.4 received a greater proportion of usage during busy periods, but the last three seem to suggest, that during peak periods W.C.4 received a reduced proportion. Without further information the situation remains unclear.

10.1.1.3 Comparative Usage on Individual Weekdays.

As previously mentioned, usage also varied somewhat, from the average pattern presented in Figure 10/1, according to the particular day of the week. Figure 10/6 presents the average half-hourly usage data, in such a way as to allow scrutiny in respect of comparative daily usage, and Figure 10/7 illustrates this data graphically.

Figure 10/8 includes details of the percentages, of average total 8 a.m. to 3 p.m. weekday usage, received per day of the week, and Figure 10/9 presents this data graphically. Considering the close approximation shown, in respect of comparative W.C. usage, between the results of the 'half-hourly' data analysis and those of the '26 week' data analysis, it was accepted that the half-hourly data was reasonably reliable.

Figures 10/6 and 10/7 illustrate that, although the proportion of 'weekday' usage, received on each particular weekday, varied, usage on each weekday conformed within limits to the pattern of overall usage as illustrated in Figure 10/1. Figures 10/8 and 10/9 show, that Tuesdays received the highest proportion of usage, that Fridays received by far the smallest proportion of usage, and that the remaining three weekdays received roughly equal usage. However, it must be stressed, that this data relates only to the period between 8 a.m. and 3 p.m. for the five weekdays.

10.1.1.4 Comparative Weekend Usage.

Excepting flushes originating from cleaning operations, as detailed in Section 9.3.3, there was virtually no usage prior to 8 a.m.. Also, on many occasions, data was collected on at least two different days within the space of the same week, sometimes on consecutive days. These two facts enabled a further analysis of facility usage. As cleaning operations were identical each weekday morning, by taking readings of W.C. usage at 8 a.m. one morning, and then again at 8 a.m. the following morning, the difference could be assumed to approximate the first days usage. This allowed for the total 24 hour usage per weekday to be estimated. However, it was not possible to estimate Friday usage in this way. No Saturday site attendance was possible, therefore the necessary 8 a.m. Saturday readings could not be obtained. Also, there were only a few occasions when site attendance occurred on consecutive days, but on many occasions attendance occurred on both a Monday and a Friday in the same week. Thus, using the 8 a.m. Monday readings and the 8 a.m. Friday readings, total usage from Monday to Thursday inclusive could be calculated.

By averaging out all such data, a figure of 1570.1 flushes, between and including Monday to Friday, was arrived at. It was necessary to assume, in order to extrapolate this data further, that the variations in usage per weekday, observed during the 8 a.m. to 3 p.m. study period, applied also to total daily usage. By applying the variations mentioned, and given in Figure 10/8, the figure of 1570.1 W.C. operations suggests the following;

Monday (24 hour usage)	381.6 operations	(20.1%)	} 1570.1 operations (82.7%)	} 1898.6 operations 100%
Tuesday (" " ")	410.1	" (21.6%)		
Wednesday (" " ")	387.3	" (20.4%)		
Thursday (" " ")	391.1	" (20.6%)		
Friday (" " ")	328.5	" (17.3%)		

From the 26 week 'around the clock' data., an average weekly total of 2174.6 W.C. operations had been arrived at. Accepting the extrapolation as outlined, this suggests an average weekend usage of 276 W.C. operations, Saturday and Sunday inclusive. Thus, assuming equal usage on Saturday and Sunday, a weekend daily usage of 138.0 W.C. operations is suggested, as compared to an average weekday usage of 379.7 W.C. operations.

Converting to percentages, these figures become 6.4% of total usage per average weekend day, the equivalent average weekday figure being 17.5%. The assumption, upon which these figures were arrived at, if not exact, must result in a reasonable approximation. Clearly, then, usage levels were considerably reduced at weekends.

10.1.1.5 Area Population and Peak Demand.

From the figures of, 1898.6 W.C. operations in total during the average working week, and 1141.4 W.C. operations between the hours of 8 a.m. and 3 p.m. during the working week, it appears that 60.1% of total weekday usage occurred between the hours of 8 a.m. and 3 p.m.. However, adjusting these figures to eliminate W.C. operations originating from cleaning operations, the total number of W.C. operations from Monday to Friday is reduced to 1853.6, and the figure of 1141.4 operations remains unchanged.

This suggests that 61.58% of total weekday usage occurred between the hours of 8 a.m. and 3 p.m.. The facility received usage until late evening, resulting in a daily usage period of at least 14 hours. It was considered reasonable to assume, as over 60% of usage occurred in the first half of the usage period, that the peak of usage, observed between the hours of 2 p.m. and 3 p.m., was indeed the daily peak.

A certain amount of information is available on the usage of sanitary accommodation in occupied buildings. Figures 10/10, 10/11 and 10/12, present data collected from observations of lavatory usage in seven offices and in a shopping centre, by Davidson and Courtney (1976) and Flenning (1977) respectively.

Davidson and Courtney (1976) found that 87% of arrivals at a female facility, during peak periods, wished to use a W.C.. Although the area served, by the facility under observation in this study, was of a different category to the office area served by the facility observed to produce Figure 10/11, it was assumed that the resultant data was applicable to this facility also. It was accepted that building usage must of necessity effect demand rates, but excepting special situations such as public houses, no reason could be found why relative usage of sanitary appliances should vary significantly according to building category.

Considering that, during the average weekday peak hour of usage, 50.6 W.C. operations were recorded, and assuming this to represent 87% of arrivals at the facility, a mean number of 4.85 arrivals in any five minute interval, during the peak hour, is suggested. However, it must be noted that this is based upon the number of people who actually used a W.C., and not upon the number of people who wished to use a W.C.. It is probable that some arrivals, during a peak period, found no W.C. vacant and therefore went away, either returning later or employing some other facility. The estimated mean, of 4.85 arrivals, is therefore a slight underestimation.

The area population, as discussed in Section 9.3.5, had been estimated at 101 - 200 females. Davidson and Courtney (1976) found the proportion of the population arriving during an average five minute interval, during the peak hour in office buildings, to be 3.5%. This proportion would suggest the area population to be 139 females in the situation under consideration. However, Flenning (1977) found that only 1% of the female population, in a shopping centre, used the sanitary facilities in this same period. It would not be unreasonable to assume, considering the differences in area usage between the office based study and the shopping centre study, that the equivalent figure for this study ought to lie somewhere between those arrived at in these two other studies. Assuming the maximum population of the area under consideration to be 200 females, as estimated in Section 9.3.5, a proportion of 2.43% of the population is suggested as arriving at the facility per average five minute interval during the peak hour.

10.1.1.6 Success Displayed in Meeting Demand.

An acceptable level of provision, it is suggested by Davidson and Courtney (1976), would result in all the appliances, of the type required to be used by an arrival, being occupied on only 1% of the occasions that he might wish to use them during a peak period. It is therefore desirable to calculate the probability that all four cubicles were occupied, at any particular moment, during the peak hour of usage. To do this, it is necessary to know something of cubicle occupation times, as well as details of the average number of W.C. operations during the relevant period. Figure 10/10 suggests two different values for mean W.C. occupation time in a female facility. Considering that the shopping centre survey was carried out in Canada, and may thus be open to cultural differences, and that an office situation would better parallel the environment under study, the figure of 80 seconds suggested by the B.R.E. survey was adopted.

Assuming that usage of each W.C. were totally independent, knowing the average number of uses of each particular W.C., and using the mean occupation time of 80 seconds, the figure of 0.006 is arrived at, as the probability of all 4 cubicles being occupied at any moment during the average weekday peak hour of usage, by employing basic probability theory.

This translates as an estimated 0.6% of arrivals during the peak period finding no vacant cubicle. However, this method of calculation is not appropriate, as the usage of cubicles was not independent, but rather inter-dependent, and the method takes no account of the distributions of either user arrival times or cubicle occupation times.

Davidson and Courtney (1976) found that arrivals at a cloakroom followed a Poisson distribution, whose mean did not vary significantly either within the hour or from one day to another. Thus the probability, 'P(n)', that 'n' users arrive in any given interval, can be calculated by the formula:

$$P(n) = \frac{m^n \cdot e^{-m}}{n!}$$

where; m = mean number of arrivals per interval.

It can be assumed, that the arrival pattern, of that proportion of arrivals wishing to use a W.C., also follows a Poisson distribution. A better estimation of the probability of all 4 W.C.s being occupied, at any moment during the average weekday peak hour, can now be made taking account of the distribution of arrival times. Again taking the mean occupation time as 80 seconds, the probability of four or more people wishing to use a W.C., arriving within an 80 second interval, is an approximation to the probability of all 4 W.C.s being occupied. In this way the probability of 0.028 was arrived at. This translates as an estimated 2.8% of arrivals, during the peak period, finding no vacant cubicle. However, to perform this calculation, it was necessary to assume, that the average number of W.C. operations recorded in the appropriate period, was identical to the average number of arrivals wishing to use a W.C.. This assumption tends to underestimate the number of arrivals wishing to use a W.C., and therefore to marginally underestimate 'P(n)', as some arrivals, on finding all four cubicles engaged, may not have waited for service. This is a better estimate than the one previously outlined, but still takes no account of cubicle occupation time distribution.

The problem under consideration here is really one of queueing theory. To solve any particular queueing problems mathematically, it is necessary to know details of the input process, the service mechanism and the queue discipline. In this case the input process, namely the distribution of arrival times, is known to be of the Poisson type. The service mechanism, namely the distribution of occupation times for Womens W.C.s, is reproduced in Figure 10/13 as compiled by Davidson and Courtney (1976). This distribution appears to be of the 'Chi'squared type. The queue discipline can reasonably well be estimated from observations. Each particular combination of input process, service mechanism and queue discipline, requires to be mathematically solved from basic principles for that specific arrangement. Unfortunately this is a complicated process, and no treatise could be found to comply exactly with the case in point. However, a method is available, known as the M/M/s queue, which approximates this situation, excepting that the associated service mechanism is a negative exponential distribution. This method is fully explained by Cox and Smith (1961) and by Cooper (1972). The exponential distribution is a reasonable one to consider when there are a large number of customers requiring fairly short service, and a smaller number of customers requiring longer service. This is true of the distribution outlined in Figure 10/13, excepting that in this case there is a definite minimum service time of 20 seconds. The resulting calculation is, then, an approximation;-

$$P(n) = S^{-1} \left(\frac{m^m}{m!} \right) \rho^n \quad (\text{where; } n > m)$$

where; $\rho = \frac{\alpha}{m \cdot \sigma}$ and $S = 1 + \frac{(m \cdot \rho)}{2!} + \dots + \frac{(m \cdot \rho)^{m-1}}{(m-1)!} + \frac{(m \cdot \rho)^m}{m! (1-\rho)}$

and where; P(n) = The probability of 'n' customers requiring to use a W.C., being in the system.

m = The mean number of cubicles.

α = mean arrival rate of W.C. users.

σ = mean service rate.

ρ = traffic density.

Thus, the probability of 4 or more people, wishing to use a W.C., being in the cloakroom at any moment during an average weekday peak hour of usage, was calculated to be 0.030. This translates as an estimated 3.0% of arrivals during the period finding no vacant cubicle. It must be noted that, again in this case, the mean arrival rate of people wishing to use a W.C., ' λ ', was calculated from the actual number of people who used a W.C., and takes no account of people who did not wait for service. The queue discipline upon which the previous calculation is based is as follows; customers who find all cubicles busy join a queue and wait as long as necessary for service, that is, blocked customers delayed (B.C.D.); no cubicle can be idle if a customer is waiting; the number of waiting positions in the queue is assumed to be infinite. These conditions approximate to cloakroom conditions only so long as queue size and waiting times are very small, as indeed they are in this case by definition of acceptable levels of provision.

To test the accuracy of the M/M/s queueing theory, for the situation under consideration, a check was made against the results of Davidson and Courtney's (1976) computer simulation of facility usage. Davidson and Courtney (1976) recommend, for women's W.C.s in offices, that a population; not greater than 25, requires 2 W.C.s; not greater than 50, requires 3 W.C.s; not greater than 100, requires 4 W.C.s. Obviously an amount of adjustment has been performed to produce convenient incremental points, but Davidson and Courtney (1976) state that such alterations were minor. The criterion, upon which these recommendations were based, was that all W.C.s provided would be simultaneously in use on only 1% of occasions during the hour of peak demand. As the mean cubicle occupation time was known from Figure 10/10, the proportion of arrivals wishing to use a W.C. was known from Figure 10/11, and the average proportion of the population arriving in a given interval was known from Figure 10/12, the traffic density, ' ρ ', could be calculated for each of the recommendations previously mentioned. In each case, as the population sizes quoted are recommended maximums, the resulting probability of simultaneous use should be 0.01 (1.0%), or slightly less. It was considered unlikely that Davidson and Courtney would have adjusted the recommended populations, in order to provide convenient incremental points, so as to cause the probability to exceed 1.0%. However, by applying the M/M/s theory, to the recommendations, the following results were obtained:-

Number of W.C.s.	Limiting Population as recommended (1).	Probability of no vacant cubicle.
2	25	1.9%
3	50	0.9%
4	100	1.0%

The large divergence, from the expected '1.0%' figure for 2 W.C.s, is explained by the fact that Davidson and Courtney (1976) modified their standard for acceptability for small populations, thus their recommendations for one or two appliances, of any given type, would not be based solely on the '1%' criterion. By the M/M/s theory, and applying only the '1%' standard, the limiting populations for the same situations would be:-

Number of W.C.s.	M/M/s Limiting Population.
2	19
3	52
4	100

It seems reasonable to assume, that the limit population, recommended for 3 W.C.s, was the result of adjustment to a convenient incremental point. Scrutiny of other of Davidson and Courtney's (1976) recommendations, by application of the M/M/s theory, gave similar results. The figures arrived at were both slightly greater than, and slightly smaller than, the expected '1.0%' figure, but Davidson and Courtney's (1976) results were always removed in the direction of an incremental point. The exception to this was, that all values arrived at, for less than 3 appliances, were greater than 1.0%. This was the result of the previously mentioned extra criteria for small populations.

It appears that the M/M/s theory is indeed a reasonably good method for approximating the acceptability of levels of sanitary provision, both quickly and easily, without recourse to lengthy simulation techniques. Having ascertained this fact, and considering the result, of 3.0%, obtained for the situation under study, it is clear that the provision of W.C.s here results in greater congestion than the standard so far discussed would suggest to be acceptable. None the less, it needs to be stated, that Davidson and Courtney's (1976) recommendation, of a '1.0%' limiting standard, must result in an extremely good service level, especially on recalling that all relevant calculations are based upon the 'peak hour of demand'. It might be suggested, that this standard was chosen to more closely approximate existing regulatory requirements, although even with such a high standard of service availability, at larger population values, less W.C.s are required per given population than the existing regulations would suggest.

Using the M/M/s theory, it is also possible to assess the level of provision of washbasins in the facility. Figure 10/10 gives the average washbasin occupation time, as found by Davidson and Courtney (1976), to be 19 seconds. The mean number of facility users arriving in any five minute interval, during the peak hour, was calculated to be 4.85 in Section 10.1.1.5. Thus, all the information required to apply the theory is available. Although Davidson and Courtney (1976) did not present details of the distribution of washbasin occupation times, it is only reasonable to assume that the distribution would more closely approximate a negative exponential than did the distribution for W.C. occupation times. The M/M/s theory should therefore be more applicable to this situation. It was considered desirable to assume, that all facility users wished to use a washbasin. Incorporating this assumption into the figures, the calculation estimates, that on 4.1% of the occasions that an arrival might wish to use a washbasin, during the mean weekday peak hour of demand, both of those provided would be in use. The provision of an extra wash basin would reduce this probability, of simultaneous use, to 0.4%.

By the '1.0%' standard the existing provision appears to be inadequate, but the assumption, that all facility users require a washbasin, though desirable, is probably a gross overestimation. Some basic research of this subject, possibly from observation, might prove fruitful.

10.1.2 The Male Facility.

Vandalism to cistern operation monitoring equipment, as experienced with the female facility and discussed in Section 9.5.9, did not occur in the case of the male facility. Data could therefore have been collected over an extremely long period. However, it was decided to record cistern operations only over the period of intense 'on site' activities at the male facility. This was done so as to ensure, that no interruptions to smooth running, such as a particular W.C. being blocked for a time, could pass unnoticed. Although the operator, during this period, was only present on site for two or three days each week, regular discussion, with cleaning staff and hospital plumbers, ensured that no irregularities went undetected. Such action had also been taken during monitoring of the female facility. Data was therefore collected over a period of 12 complete weeks, during which time there were no unusual occurrences which could have distorted results, and thus the figure of 244.7 W.C. operations in total per average week was obtained. As in the case of the female facility, half-hourly readings of cistern operation counters were taken throughout all 'on site' periods, and therefore a considerable amount of short term data was also available. However, due to difficulties of technician assistant availability, it happened that time 'on site' was restricted to Tuesdays, Wednesdays, and Fridays. Thus, the usefulness of the short term data was somewhat limited in this case.

10.1.2.1 Average Usage During 'On Site' Periods.

Figure 10/14 illustrates the average half-hourly combined usage, of both W.C.s, for the average 'on site' weekday. The data upon which this figure is based, being effected by the restriction outlined in 10.1.2 above, was collected between the hours of 8 a.m. and 3 p.m.. It can be seen, that general levels of usage, as expected, were considerably lower than those observed for the female facility.

Although this figure is based upon 25 days of 'on site' monitoring, and probably due to the extremely low levels of usage, the average pattern of weekday usage appears rather erratic. Peaks and troughs of usage are much less easy to distinguish, than was the case with the female facility, usage being more evenly spread over the day. However, extra high usage seems to have occurred between the hours of 11 a.m. and 11.30 a.m., and again between 2 p.m. and 2.30 p.m, the morning peak being the highest. It is interesting to note that, in this case, the durations of increased activity appear to be limited to half-hourly or shorter intervals, but this could merely be a product of distortion, resulting from the low numbers of operations being counted. As was the case with the female facility, apart from discharges originating from cleaning operations, as detailed in Section 9.3.3, usage prior to 8 a.m. was virtually non existent.

10.1.2.2 Comparative Usage of Individual W.C.s.

The base data, in terms of half-hourly usage per individual W.C., per particular day of the week, is presented in Figure 10/15. Figure 10/16 presents this data in such a way as to allow scrutiny in respect of comparative W.C. usage. Figure 10/18 includes details of the percentages of total usage received by particular W.C.s, based upon the continuous monitored 12 week data, compared to similar figures originating from the average half-hourly usage data. Figure 10/20 presents this same data graphically.

It can be seen, from Figures 10/18 and 10/20, that, irrespective of the particular day of the week, the data consistently indicates the proportions of total usage received by each W.C. during on site monitoring periods, and indeed over the whole study period, to be disproportionate, W.C.6 receiving preferential use. Figures 10/15 and 10/16 illustrate that over an average weekday, with minor fluctuations, W.C.6 received fairly constant levels of usage throughout the greater part of the study period. W.C.5 also received fairly constant, but lower, levels of usage over the same period, except during the period of peak usage between 11 a.m. and 11.30 a.m.. During this peak demand, both W.C.s received similar levels of usage.

It is reasonably apparent, that a marked preference was shown for W.C.6, and the more equal usage displayed during peak periods merely indicates, that W.C.5 was used, contrary to preference, when W.C.6 was engaged. Although the possible reasons for customer preferences are many, as discussed in Section 10.1.1.2, in this case an obvious reason is apparent. As discussed in Section 9.3.4, an automatic door closer was provided at the entrance to this facility, but it did not function satisfactorily. The closing action was slow, and the door did not close completely without assistance. W.C.5 was directly opposite the facility entrance, see Figure 9/4. Due to insufficient screening and the lack of a suitable lobby, direct visibility of W.C.5 from the cafeteria area was at times unavoidable. Considering that there were dining tables within two metres of the entrance, and as the cubicle partitioning was not fully from floor to ceiling, the social unacceptability of the situation is apparent. It is obvious, from the avoidance of W.C.5 by facility users, that this unacceptability was felt as much by facility users as it must have been by cafeteria customers dining nearby.

10.1.2.3 Comparative Usage on Individual Weekdays.

Figure 10/17 presents the average half-hourly usage data in such a way as to allow scrutiny in respect of comparative daily usage. Figure 10/19 includes details of the percentages of average total 8 a.m. to 3 p.m. weekday usage, received per day of the week, and Figure 10/21 presents this data graphically.

As mentioned in Section 10.1.2, time 'on site' was restricted to Tuesdays, Wednesdays, and Fridays, and consequently, analysis of usage per day of the week was restricted. From Figures 10/19 and 10/21, it is apparent that Tuesdays were busier than Fridays, and that the least usage over the three days occurred on Wednesdays. A certain amount of extrapolation was possible to further illuminate the pattern of overall weekly usage. Cleaning operations were identical each weekday morning, and as virtually no other usage occurred prior to 8 a.m., the difference between the readings of W.C. usage recorded at 8 a.m. one morning, and similar readings recorded the following morning at the same time, could be assumed to approximate the total 24 hour usage for the first of the two days.

As site visits occurred on Tuesdays and Wednesdays, the mean total 24 hour usage for Tuesdays could be calculated. Knowing the relative usage received between Tuesdays, Wednesdays and Fridays, during 'on site' monitoring periods, and assuming these proportions to apply for total daily usage also, the total 24 hour mean usage for Wednesdays and Fridays could be calculated. By performing a comparison, between the 8 a.m. Wednesday readings and the 8 a.m. Friday readings, the mean total 48 hour usage, for Wednesday and Thursday together, could be calculated. Knowing the mean total 24 hour usage for Wednesday, the similar figure for Thursday could be calculated. These extrapolations gave the following results:

Tuesday	(24 hour usage)	49.9	W.C. operations	(27.0%)	} 184.9 operations (100%)
Wednesday	(" " ")	40.2	"	" (21.7%)	
Thursday	(" " ")	50.5	"	" (27.3%)	
Friday	(" " ")	44.3	"	" (24.0%)	

Assuming Mondays to have received exactly one fifth of weekday usage, a comparison can be made to the 24 hour usage data for the female facility presented in Section 10.1.1.4.

Monday	(24 hour usage)	46.2	W.C. operations	(20.0%)	} 231.1 operations (100%)
Tuesday	(" " ")	49.9	"	" (21.6%)	
Wednesday	(" " ")	40.2	"	" (17.4%)	
Thursday	(" " ")	50.5	"	" (21.8%)	
Friday	(" " ")	44.3	"	" (19.2%)	

Tuesdays and Thursdays received the highest levels of usage, the proportion of weekday usage received on Tuesdays being exactly the same as was the case for the female facility, and that for Thursdays being slightly higher than was the case for the female facility. The most notable difference, between this facility and the female facility, was that Wednesdays received markedly lower usage than other weekdays in this case, whereas Fridays received similarly low usage at the female facility.

From Figure 10/17, it is clear that the pattern of usage, throughout the day, varied somewhat according to the day of the week. However, this erratic variation is explained simply, the quantum effect of counting low numbers of operations seeming to cause distortion. Monitoring would have had to have been extended considerably to gain enough data to negate this effect.

10.1.2.4 Comparative Weekend Usage

As previously mentioned, in Section 9.3.3, the male facility was closed each Saturday at noon, and reopened first thing on the following Monday morning. Thus, weekend usage was unnaturally restricted. By comparing readings of W.C. operations recorded at 8 a.m. on Fridays against those recorded at 8 a.m. on the following Tuesdays, a value for mean total usage over the period Friday, Saturday morning and Monday, was estimated to be 110.7 operations. Having estimated total Friday usage in Section 10.1.2.3, and assuming total Monday usage to have been exactly one fifth of total weekday usage, the figure of 20.1 W.C. operations per average Saturday morning was arrived at. However, this estimation was based on data taken over six weekends only, and as such could be subject to some variability. Having estimated mean Tuesday to Friday usage, in Section 10.1.2.3, and again assuming total Monday usage to have been exactly one fifth of total weekday usage, the figure of 231.1 was arrived at for total weekday usage. Knowing, from Section 10.1.2, that the mean weekly number of operations was 244.7, the figure of 13.6 was arrived at for mean Saturday morning operations, including flushes originating from cleaning activities. Adjusting this value, to 8.6 W.C. operations, by excluding cleaners' flushes, and comparing it to the respective value for mean weekday morning usage of 13.5 W.C. operations, it appears that the Saturday morning usage was 63.7% of mean weekday morning usage.

The mean weekend usage over Saturday and Sunday was found, in Section 10.1.1.4, to be 276.0 W.C. operations at the female facility, compared to an average weekday usage of 379.7 W.C. operations. Adjusting these values, to exclude flushes originating from cleaning activities, they become 258.0 and 370.7 respectively. Thus, the weekend usage level at the female facility was found to be 34.8% $((258.0/2)/370.7)$, of mean weekday usage.

It would not be unreasonable to assume that, proportionally and with respect to time, major variations in usage levels of the two facilities would not have been dissimilar. Thus, from the values of 63.7%, as the proportion of mean weekday morning usage received on the average Saturday morning at the male facility, and 34.8%, as the proportional level of mean weekend day usage as compared to mean weekday usage, it is suggested that the female facility must have received proportionally more usage on Saturday morning than over the remainder of the weekend, and that demand for the male facility, were it not for closure, would have been considerably reduced during Saturday afternoon and Sunday.

10.1.2.5 Area Population and Peak Demand.

The proportion of usage received by the facility during the average weekday monitoring period, of from 8 a.m. to 3 p.m., was 53.1% of the 24 hour average weekday usage. Adjusting the figures to eliminate use of W.C.s originating from cleaning operations, which occurred daily prior to 8 a.m., the proportion becomes 59.5%. However, as monitoring activities, at the male facility, were only conducted on Tuesdays, Wednesdays and Fridays, a more acceptable estimation, of the proportion of 24 hour usage received during the monitoring period, would take into account mean daily usage over these three days only. In this way the proportion of daily usage received during the monitoring period was calculated to be 54.7% of mean 'on site' weekday usage, and after adjustment to exclude all W.C. operations originating from cleaning activities this value becomes 61.60%. This value of 61.60% compares well with the respective figure of 61.58%, as calculated in Section 10.1.1.5, which was the proportion of female facility usage received during the same period. This indicates that the assumption made in Section 10.1.2.4, that proportionally major variations in usage levels of the two facilities, with respect to time, would not have been dissimilar, is indeed correct. Considering that daily usage of the male facility was spread over at least 14 hours, and that over 60% of usage occurred in the 7 hours of the monitoring period, it was thought reasonable to assume that the daily peak of demand occurred during the monitoring period.

Figure 10/11 presents details of the relative usage of sanitary appliances, during peak periods in office accommodation, for male and female facilities, and Figure 10/12 indicates that the number of facility users as a proportion of the respective total population was less, for a male facility, than for a female facility during peak periods. Considering total usage, and not just peak period usage, it would seem reasonable to assume that the relative proportions of particular populations requiring either to urinate or defecate would be identical for males and females. This suggests that the varying proportions of facility usage received by particular appliances at male and female facilities, as presented in Figure 10/11, may be the result of an extra proportion of females requiring to use a washbasin only, an indication of a higher standard of personal hygiene amongst females. This seems reasonable, as women might be expected to utilise a cloakroom simply to adjust their personal presentation.

From Figure 10/22, it can be seen that 9.0% of monitored flushes at the female facility contained faecal material, thus it was assumed that all other monitored flushes, 91.0%, were the result of urination.

Using these proportions, accepting the proportions of arrivals requiring only to use a washbasin to be as presented in Figure 10/11, and assuming the relative proportions of particular populations requiring to urinate or defecate to be identical for males and females, the following figures were arrived at concerning the relative usage of sanitary appliances in the situation under study;

	Male	Female
Arrivals using washbasin only	10.0%	13.0%
Arrivals requiring to urinate	81.9%	79.2%
Arrivals requiring to defecate	8.1%	7.8%

This suggests the proportion of arrivals at a male facility, during a given period, to be 96.7% of arrivals at a female facility over the same period, assuming identical population size and assuming the number of arrivals requiring to urinate or defecate to be the same in each case. This model, then, allows solely for extra washbasin usage at female facilities.

Using the values of 3.0% and 3.5%, for the male and female facilities respectively, as the proportions of the relative populations arriving at facilities during an average 5 minute interval during the hour of peak demand, as is given in Figure 10/12 for office buildings, the figure of 85.7% is arrived at as the proportion of male arrivals as compared to female arrivals for identical populations. However, this situation is complicated somewhat. The values of 3.0% and 3.5%, as quoted, are not the exact averages of the measured data for the seven locations as presented in Figure 10/12. By taking exact averages of Davidson and Courtney's (1976) results, the value of 96.6% (3.14%/3.25%), is arrived at as the proportion of male arrivals as compared to female arrivals during peak periods. Obviously the data presented in Figure 10/12 have been rounded off to convenient values, and without access to Davidson and Courtney's (1976) base data the reasons for adoption of the figures 3.0% and 3.5% are unclear. The value of 96.6%, as calculated from Davidson and Courtney's (1976) results, compares well with the value of 96.7% calculated solely to allow for extra washbasin use at female facilities.

It is evident, then, that Davidson and Courtney's (1976) results confirm the assumption that, over a given period, the relative proportions of particular populations requiring to urinate or defecate are identical for males and females. This must be viewed in context with the assumption, confirmed earlier in this section from the results of this study, that proportionally major variations in usage levels at male and female facilities, with respect to time and provided no special circumstances exist, are the same. This last assertion can be rechecked by calculating the proportions of 24 hour mean weekday usage received by each of the facilities during the hour of peak demand. Excluding W.C. operations originating from cleaning activities, it was found that, at the male facility, 12.7% of mean weekday usage was received during the hour of peak demand. However, as previously mentioned, due to the fact, that monitoring activities at the male facility were only conducted on Tuesdays, Wednesdays and Fridays, a more acceptable estimate, of the proportion of 24 hour usage received during the hour of peak demand, would take into account mean daily usage over these three days only.

In this way, the proportion of daily usage received during the hour of peak demand, at the male facility, was calculated to be 13.1%, again excluding all W.C. operations originating from cleaning activities. The comparative value for the female facility was 13.7%. These values are reasonably similar, but highlight the fact that, the shorter the period under study, the greater the effect of minor variations with respect to time. It must also be remembered, that some variations in system usage are known to have occurred (for instance, peak demand occurred between 2 p.m. and 3 p.m. at the female facility, and between 10.30 a.m. and 11.30 a.m. at the male facility).

As 50.6 W.C. operations occurred during the hour of peak demand on the average weekday at the female facility, and using the figure of 9.0% quoted earlier in this section as the proportion of W.C. operations containing faecal material, it is suggested that 4.6 flushes, during this period, contained faecal material. As population size was estimated to be identical for males and females, in section 9.3.5, it would be expected that 4.6 'faecal' flushes occurred at the male facility during the hour of peak demand. The expected number of defecations, between 8 a.m. and 3 p.m. on the average weekday, was similarly calculated to be 20.6. In fact there were 5.2 W.C. operations during the hour of peak demand, and 24.5 W.C. operations between 8 a.m. and 3 p.m. on the average weekday. It appears that the male facility received greater use than had been expected. However, Figure 10/22 indicates that only 41.3% of monitored flushes, at the male facility, contained faecal material. Thus, during the hour of peak demand, it follows that there were only 2.2 defecations on average at the male facility. From the figures calculated earlier in this section, concerning requirements of arrivals at a male facility, this suggests that there were 26.6 arrivals during the hour of peak demand. The expected value was 56.3 (96.7% of 58.2). Clearly, then, other factors were at work here. The number of W.C. operations recorded included many water only and paper only flushes. This is an indication that W.C.s were frequently used as urinals, and this topic is discussed further in Section 10.1.2.6.

The number of W.C. operations recorded, therefore, included a proportion of what would normally be expected as urinal uses. Excluding these flushes, the number of faecal flushes remaining was unexpectedly low. It follows, that the number of people using the male facility must have been much smaller than expected. This is not an indication of reduced proportions of the male population requiring to use appliances, but merely an indication that a significant proportion of prospective users employed alternative facilities. A second male facility did exist, in an adjacent department, within reasonably close proximity. Thus, the effective male population was smaller than had been estimated in Section 9.3.5.

In Section 10.1.1.6, it was estimated that 2.43% of the female population arrived at the female facility per average 5 minute interval during the mean weekday peak hour of demand. Employing the figure of 96.7% calculated earlier in this section, as the proportion of male arrivals, as compared to female arrivals, for identical populations, it is estimated that 2.34% of the male population arrived at the male facility per average five minute interval during the hour of peak demand. Bearing in mind, that 26.6 arrivals were estimated over the mean peak hour, this suggests a male population of 95 persons. This compares to the estimated female population of 200 persons.

10.1.2.6 Success Displayed in Meeting Demand.

Prior to numerical analysis of male facility usage, as regards relative demand for appliances and the ability of the appliances provided to satisfactorily meet such demand, some clarification is necessary.

On considering flush content at evacuation from the W.C. at the female facility, taking no account of other solids, encountered as stoppages from the previous flushes, which had been deposited in the service pipework, it seemed reasonable to assume, that only those discharges which contained faecal material were the result of defecation. All other flushes might be considered as the result of urination, whether they contained no solids at all, or non-faecal solids only.

It would then be expected, that the proportion of 'faecal' to 'non-faecal' discharges, at the female facility, would closely approximate the proportion of W.C. uses to urinal uses at the male facility. Thus, the number of W.C. operations, recorded at the male facility, would approximate the number of discharges at the female facility which contained faecal material, as the respective populations had been estimated, in Section 9.3.5, to be equal, and as calculations presented in Section 10.1.2.5, and based on Davidson and Courtney's (1976) results, had indicated that differences in arrival rates, between male and female facilities, were due solely to different demand rates at washbasins.

However, a more realistic view is as follows. Even considering a facility with ample and socially acceptable urinal provision, it is extremely probable, that some arrivals at a male facility, requiring only to urinate, will use a W.C. to this end and not a urinal. It is also probable, that some arrivals will employ a W.C., not merely to urinate, but will not defecate. This last group may include people intending to defecate, but who are constipated; people performing some other personal hygiene activity who require the privacy of a W.C. cubicle, and who may or may not dispose of some non-faecal material via the W.C.. It would therefore have been expected, given adequate urinal provision, that the number of W.C. operations, at the male facility, would reflect the number of 'faecal' flushes monitored at the female facility, and include an extra amount of 'non-faecal' flushes attributable to these other activities as previously outlined. However, the recorded results indicate, that usage of the facility under study did not conform to this simple pattern.

In Section 10.1.2.5, it was shown that Davidson and Courtney's (1976) results are consistent with the assumption, that the total numbers of people requiring either to urinate or defecate, or use a W.C. for some other purpose, given identical population sizes, are identical for male and female facilities over a given period.

This does not confirm, that the numbers requiring to perform any one of the given activities are identical in each case, merely that the total numbers over all these activities are the same. However, this former contention is a natural extension from the proven hypothesis, and appears to be a reasonable assumption.

The number of W.C. operations, at the female facility, must have included all urinations, defecations, and uses of W.C.s for other activities. Figure 10/22 indicates the proportion of female W.C. operations containing faecal material to have been 9.0%. Thus, it can be assumed, that 9.0% of combined urinal and W.C. use, at the male facility, was the result of defecation. Davidson and Courtney's (1976) results, as presented in Figure 10/11, indicate that 12.2% (11%/(11%+79%)), of those arrivals employing either a urinal or a W.C., used a W.C.. A reasonable approximation, therefore, of the number of males using a W.C. for purposes other than defecation, assuming adequate urinal provision, is suggested to be 3.2% (12.2%-9.0%), of those arrivals requiring either to use a urinal or a W.C.. Employing these proportions, and accepting the proportions of total arrivals at facilities, requiring to use a washbasin only, to be as found by Davidson and Courtney (1976), see Figure 10/11, an update of the table presented in Section 10.1.2.5, concerning relative demand for particular sanitary appliances at male and female facilities, can be compiled in respect of total arrivals at each facility;

	Male	Female												
Arrivals using washbasin only	10.0%	13.0%												
Arrivals using a urinal	79.0%	-												
Arrivals using a W.C. pan	<table border="0"> <tr> <td rowspan="2" style="font-size: 3em; vertical-align: middle;">{</td> <td>for defecation</td> <td>8.1%</td> <td rowspan="2" style="font-size: 3em; vertical-align: middle;">}</td> <td rowspan="2" style="vertical-align: middle;">11.0%</td> </tr> <tr> <td>for some other purpose</td> <td>2.9%</td> </tr> </table>	{	for defecation	8.1%	}	11.0%	for some other purpose	2.9%	<table border="0"> <tr> <td rowspan="2" style="font-size: 3em; vertical-align: middle;">}</td> <td>7.8%</td> <td rowspan="2" style="font-size: 3em; vertical-align: middle;">}</td> <td rowspan="2" style="vertical-align: middle;">87.0%</td> </tr> <tr> <td>79.2%</td> </tr> </table>	}	7.8%	}	87.0%	79.2%
{	for defecation		8.1%	}			11.0%							
	for some other purpose	2.9%												
}	7.8%	}	87.0%											
	79.2%													

However, it must be borne in mind, that Davidson and Courtney's (1976) values, concerning relative demand for appliances, were arrived at from study of office buildings, and it is possible, that the respective proportions for this case study may not have been identical.

It had been intended, that the observed proportion of 'non-faecal' flushes, at the male facility, be compared to the value presented in the table above, to either confirm or disprove that these relative demand rates are widely applicable for dissimilar locations.

Unfortunately, use of W.C.s for urination, due to inadequate urinal provision, rendered such comparison invalid. Not only was urinal provision inadequate in terms of the number of appliances, but it was also found, by observation, that those provided were considered socially unacceptable by a significant proportion of the population. A definite trend was noted, that prospective urinal users were loathe to use a urinal if the other was already in use.

As previously outlined, in Section 9.3.2, two urinals were provided at 640 mm. centres, and with no individual screening, at the male facility. These urinals were of the individual bowl type, each close coupled to, and contained within the same vitreous china housing with, its own automatic flushing cistern. It appears that, at this time, there is no British Standard which sufficiently defines an acceptable standard of urinal installation. B.S. 4880 (1973) deals with the standard of manufacture of stainless steel slab urinals, and B.S. 5520 (1977) covers the standard of manufacture of vitreous china bowl urinals. The British Standard Code of Practice, C.P. 305 (1974) purports to outline the selection, installation and special requirements of urinals, but is without doubt inadequate insofar as social acceptability is concerned, if not as regards technical acceptability of appliances. Manufacturers recommend from between 610 mm. to 690 mm. as the separation distance, centre to centre, for installation of bowl urinals. The scope of this work was insufficient to result in recommendations concerning an acceptable separation distance for urinals. However, it must be recommended that, if it be desired that urinals be used whenever possible, much more attention must be directed toward the social acceptability of urinals, such as sufficient spacing and the provision of adequate divisions between urinals.

As urinal provision had been considered inadequate from the outset of this study, the exact time of each flush monitored at the male facility was recorded. With this data, a breakdown of flush content, at evacuation from the W.C., was compiled with respect to time of day. Figures 10/23, 10/24, 10/25 and 10/26, present this data in relation to successively decreasing demand rates, in tabulated and graphic forms respectively, for half hourly intervals and hourly intervals respectively. It was suspected, that these figures would show an increased proportion of 'non-faecal' flushes at peak periods, indicating a greater amount of diversion from urinals with increased congestion at the facility. However, it appears that no distinct relationship existed between the proportion of 'non-faecal' flushes and the level of facility usage. Nonetheless, bearing in mind the previously mentioned observation, that with only one arrival employing one urinal, subsequent arrivals were loathe to use the second urinal, significant diversion from urinals at all times, and not just during peak periods, might well have been expected.

Figure 10/22 indicates that 58.7% of male W.C. discharges contained no faecal material, as opposed to the predicted proportion of 26.3% (3.2%/12.2%), estimated from calculations presented earlier in this Section, which pre-supposed adequate urinal provision. This indicates that approximately 21.8% $((9.0\%/41.3\%) \times 100)$, of arrivals wishing to either use a urinal or a W.C., actually used a W.C., as opposed to the predicted value of 12.2% which again pre-supposed adequate urinal provision. Thus, it is suggested that 10.9% $((21.8\% - 12.2\%) / (79.0\% / 90.0\%))$, of arrivals who would normally have used a urinal, were diverted to a W.C due to inadequate urinal provision.

This is the only reasonable explanation of the observed high proportion of non-faecal discharges at the male facility. The divergence from the expected is too great to be attributable merely to non-standard user requirements. That the given explanation were indeed the case would have been absolutely undeniable, were it not for the fact that, as discussed in Section 10.1.2.5, the effective male population for this facility proved to be considerably lower than expected. This tended to cause a reduction, whereas the fact of inadequate urinal provision tended to cause an increase, in the number of W.C. operations which occurred.

Thus, the partial balance between these two factors resulted in the overall number of male W.C. operations being not too dissimilar from the number which would have been predicted had neither of these factors arisen. Even so, the explanation so far outlined is believed to be sufficiently proven.

The criteria, for an acceptable level of provision of sanitary appliances, was taken to be that level which would result in all the appliances, of the type required to be used by an arrival, being occupied on only 1.0% of occasions during the hour of peak demand. This standard is suggested to be appropriate in Section 10.1.1.6, where the best available method of approximating the probability of simultaneous use of appliances mathematically, and without recourse to lengthy simulation techniques, is indicated to be via use of the M/M/s queueing theory. It was estimated in Section 10.1.2.5 that, on the average weekday during the hour of peak demand, there were 26.6 arrivals at the male facility. This value, in conjunction with the details presented earlier in this section, concerning the proportional demand for, and actual usage of, particular appliances, allowed the following two tables to be compiled. The first estimates the numbers of people who required to employ, and the second the numbers who actually employed, particular types of appliances during the mean weekday peak hour of demand;

Appliance required to be employed	No. of arrivals	Proportion as of total arrivals.
Washbasin only.	2.66	10.0%
Urinal.	20.99	79.0%
W.C. for purpose of defecation.	2.15	8.1%
W.C. for some other purpose.	0.77	2.9%
		} 11.0%

Appliance actually employed.	No. of arrivals	Proportion of total arrivals.
Washbasin only.	2.66	10.0%
Urinal.	18.69	70.4%
W.C. for purpose of urination.	2.29	8.6%
W.C. for purpose of defecation.	2.15	8.1%
W.C. for some other purpose.	0.77	2.9%
		} 19.6%

These values, along with the data concerning the mean occupation times for sanitary fittings, presented in Figure 10/10, as found by Davidson and Courtney (1976), allowed for the M/M/s queueing theory to be applied to each type of appliance in turn.

Taking no account of the observed extra diversion to W.C.s from urinals, but allowing that 2.9% of total arrivals at the facility used a W.C. for purposes other than defecation, it was calculated, that on 2.3% of occasions, during the hour of peak demand, both urinals would have been simultaneously in use. Although this indicates a higher level of congestion than might be advisable, closer examination allows for this value to be viewed in context. The formula presented in Section 10.1.1.6, and referred to as the M/M/s theory, is only valid where 'n', the number of customers requiring to use an appliance of the type being examined, is greater than or equal to the number of those appliances provided. In other words, it is not valid, by application of this formula, to calculate the probabilities of either zero customers, or one customer, requiring to use such an appliance, if only two of those appliances were provided. However, the formula presented below, also a part of the M/M/s queueing theory (and for which all notation is as defined in Section 10.1.1.6), is valid only if such be the case;

$$P(n) = S^{-1} \cdot \frac{(m \cdot \rho)^n}{n!} \quad (\text{where; } n < m).$$

Thus, the following results were arrived at concerning the 20.99 people who, during the mean weekday peak hour of demand, required to use a urinal;

P (0)	=	0.796	∴	16.70	people found both urinals vacant.
P (1)	=	0.181	∴	3.80	" " one urinal only in use.
P (2 or more)	=	0.023	∴	0.49	" " both urinals in use.
		<hr/>			
TOTAL		1.000	TOTAL	20.99	people.

Diversion to a W.C., of those people who found both urinals in use, would have had an insignificant effect on the number of W.C. operations recorded. However, calculations earlier in this section indicated that, of those arrivals who, at an installation with adequate and socially acceptable urinal provision, would normally have employed a urinal, 10.9% were diverted to a W.C.. Thus, 2.29 people diverted to a W.C. during the mean peak hour of demand. It may be assumed that, of the prospective users, those who found both urinals occupied diverted to a W.C., and those who found neither in use proceeded to employ a urinal. It follows that 60.4% ($2.29/3.80$), of the prospective users who found one urinal only in use, diverted to a W.C. instead of employing the second urinal.

The M/M/s theory was also applied to assess the level of provision of W.C.s. If there had been adequate urinal provision, and therefore no extra use of W.C.s due to diversion from urinals, but allowing that 2.9% of total arrivals at the facility used a W.C. for purposes other than defecation, it was estimated, that on 2.1% of occasions, during the hour of peak demand, both W.C.s would have been simultaneously in use. In order to extend the calculation to model the actual situation, and thereby take account of the diversion to W.C.s from urinals, some minor calculations were required concerning W.C. occupation times. For the 11.0% of arrivals who required to use a W.C., Figure 10/10 indicates the appropriate mean occupation time to be 267 seconds. The same figure indicates the appropriate mean urinal occupation time to be 39 seconds. Thus, on the information available, the mean occupation time appropriate to this situation was calculated to be 167 seconds ($((11.0 \times 267) + (8.6 \times 39)) / 19.6$). The M/M/s theory, employing this value and based upon the actual number of W.C. operations recorded, estimated that on 2.6% of occasions, during the peak hour of demand, both W.C.s were simultaneously in use.

It appears from this result that, although the population at the male facility was estimated in Section 10.1.2.5 to be 95 persons only, the degree of success displayed in meeting demand for W.C.s was less acceptable than might initially have been expected.

That this was the case, it seems, was due very little to the amount of usage received by diversion from urinals, as urination times were relatively short. However, employing the assumption that, of those people wishing either to urinate, defecate, or use a W.C. for some other purpose, the proportions of each would be identical for male and female facilities, some further calculations are possible. Taking the mean W.C. occupation time, of W.Cs at the female facility, overall, to have been 80 seconds, and for those arrivals either defecating or using a W.C. for purposes other than urination to have been 267 seconds as at the male facility, see Figure 10/10, then the mean occupation time for females using a W.C. for urination transpires to have been 54 seconds $((80 \times 90) - (11 \times 267)) / 79$. In all previous calculations, appliance occupation times adopted, as presented in Figure 10/10, were as found by Davidson and Courtney (1976) for office based studies. Never the less, data is also presented, in Figure 10/10, from the results of a study at a shopping centre. These results suggest the mean occupation time, for those males employing a W.C. for urination only, to have been 54 seconds, whereas the office based study presented no comparable value. This compares well with the respective value of 54 seconds estimated above for the female installation. It would seem reasonable that urination at a W.C. would consume slightly more time than at a urinal. Thus, a re-evaluation of the degree of congestion at the male W.C.s is suggested. The mean occupation times were taken to be, 267 seconds for the 11% of arrivals who would normally have used a W.C., and 54 seconds for those arrivals diverted from urinals. This suggested an overall occupation time of 173 seconds $((11 \times 267) + (8.6 \times 54)) / 19.6$. Application of the M/M/s theory indicates that, if this had been the case, both W.C.s would have been in use, simultaneously, on 2.8% of occasions during the hour of peak demand.

To summarise congestion at male W.C.s, if there had been no diversion from urinals, the value accepted as a measure of demand, the probability of simultaneous use of appliances, would have been 2.1%. Although there is some doubt as to the mean occupation time of males employing a W.C. for urination only, on taking account of all diversion from urinals to W.C.s, it appears that the measure of congestion lies somewhere between 2.6% and 2.8%.

The value of 2.1% suggests inadequate W.C. provision even for normal use, but the extra uses, received as the result of urination, caused relatively little increase in congestion. A more important effect of such usage is the unnecessary discharge of extra flushes through the drainage system. The question for designers, of whether or not to invest in more socially acceptable urinal provision, becomes a matter of priorities. Extra flow through the service pipework can only assist in clearing solids deposited by other flushes, but an adequately designed system would not require such assistance. The initial outlay, for more socially acceptable and spacious urinal provision, must be balanced against the continuous and unnecessary use of water. It was estimated that, in this case, 17.6 discharges per average weekday, amounting to 160 litres of flush water, were the result of diversion from urinals. This must be viewed in context with the facts, that 2.9% of arrivals were assumed to use a W.C. for purposes other than defecation, irrespective of urinal provision, and that diversion from urinals, of those arrivals only who found both urinals in use, would have had negligible effect.

Application of the M/M/s theory to the standard of washbasin provision, having assumed that all arrivals at the facility wished to use a washbasin, indicated that there would have been no vacant washbasin on only 0.8% of occasions during the hour of peak demand. As stated in Section 10.1.1.6, the assumption that all facility users require a washbasin, although desirable, is most doubtful. However, even if this were the case, washbasin provision could satisfactorily cope with the demand. It is interesting to recall that, at the male and female facilities, two washbasins were provided in each case. This, despite the fact that the female population was more than twice the size of the male population.

10.2 Flush Content and Solid Deposition.

Although, to reassess the efficiency of above ground hospital drainage systems, measurements of waste solid velocity were to provide the backbone of the information required, such information alone could not sufficiently define a 'typical' site situation.

An assessment was made, in Section 10.1, as to the 'normality' of usage patterns at the monitored facilities. Having pinpointed the peculiarities of the particular facilities studied, estimates of what might be expected at a 'normal' facility could be made. Basic measured information, concerning the proportional rate of occurrence of particular flush types, was an essential pre-requisite of such examination.

Comparisons between waste solid velocities recorded under different test conditions were required. For example, for similar flush types monitored at different drain layouts, or for similar flush types and drain layout but monitored at different facilities, or at similar drain layout and facility but for different types of flush. In each case it was necessary to evaluate the 'normality' of the mean flush content, or divergence from the same, for each 'test body' of results. Obviously, only those flushes which were recorded under similar conditions could be included in one 'test body', and, as a result, the number of constituent flushes was limited in each case. Some flushes had encountered stoppages, from previous flushes, deposited in the monitored length of pipework. Such flushes were variously and adversely affected, and could not be included in comparative velocity analyses. This further limited the number of flushes per test group. It was unavoidable that the waste material content, of those flushes classified to be of similar type, would vary from flush to flush as regards number, geometry and composition of constituent solids. As the number of flushes in any one velocity 'test body' was strictly limited, it could not be expected that mean flush content would be sufficiently similar for different tests of the same flush type. To overcome this problem, it was considered that a best approach would use all the descriptive data recorded over all monitored single flushes, as regards flush content, irrespective of the W.C. of origin, the pipe gradient or any stoppages met, to arrive at as comprehensive a definition as possible of the mean waste solid content of each flush type at each facility.

Having achieved this , the mean waste solid content of any individual tests could be compared to the 'master' definition of the particular flush type involved. Thus, a better understanding of the waste solid velocity results might be attained.

Study of waste solid deposition was considered useful, outside the specific context of velocity monitoring, in that it could assist in identifying relative characteristics of particular solid types, and also allow some understanding of the interaction of flushes which could less easily be acquired from solid velocity data.

10.2.1 Simultaneous Discharges.

The term 'simultaneous discharge' is used to describe those flushes which, within the appropriate length of monitored pipework, overlapped with another flush. Solids contained within such flushes displayed considerably greater velocities than would otherwise have been the case. Of all such flushes observed, irrespective of previous stoppages encountered, not one deposited any solid in the monitored length of soilpipe. It was considered acceptable, as all discharges were of random solid content, to preclude simultaneous discharges from analyses in respect of flush content. In statistical terms, the sample of all 'single flushes' was simply a different estimate of the same parent population. This approach was desirable as on occasion it proved impossible, given overlapping discharges, to determine the W.C. of origin of each solid. As regards solid transport, and therefore solid deposition, it was required to consider the 'worst case' situation. Exclusion of simultaneous discharges from analyses achieved this, and rendered results applicable to single W.C. branch pipes.

At gradients of 1:150 and 1:200, 2,163 flushes were monitored at the female facility. Of these 7.6% were involved in simultaneous discharge of the two W.C.s. At the male facility, and at a gradient of 1:150, 50 flushes were monitored. Of these 1.2% were involved in simultaneous discharges. The fact of fewer simultaneous discharges at the male facility was simply due to the lower level of W.C. usage at this facility, see Section 10.1.

It was on the 'single flush' data remaining, 1,004 discharges at a gradient of 1:150 at the female facility, 955 discharges at a gradient of 1:200 at the female facility, and 499 discharges at a gradient of 1:150 at the male facility, that analyses of flush content, solid transport, and solid deposition were based.

10.2.2 Flush Content.

Analyses, in respect of flush content, were based on content at evacuation from the particular W.C. concerned. That is, no account was taken of solids encountered as stoppages, deposited in the service pipework, from previous discharges. The results, therefore, closely reflect individual user solid disposal, the arrangement of the service soilpipe being irrelevant in this respect, and thus allow for comparison between facilities. The details of flush content presented only closely reflect, and do not exactly reflect, actual solid disposal at any one W.C. use, as some solids may not have cleared the W.C. with the flush immediately following placement in the pan. This phenomenon would be expected to occur, to a very limited degree, at all facilities. The results, therefore, allow qualitative and limited quantitative understanding of the pattern of W.C. usage, at male and female facilities, as regards the types and proportions of types of loads placed in the W.C.s.

10.2.2.1 Classification of Solids.

As outlined in Section 9.6, a solid identification code was developed to more easily record and store information concerning solid geometry and material. This type of information was obtained by observation, and as such is of limited value. Nonetheless, certain conclusions may be drawn from analyses of these data, but first it is necessary to outline some particular details concerning the method of classification of solids.

On many occasions faecal material was observed, not in the form of either a single and reasonably sized solid, or in the form of several such solids, but in the form of a multitude of small spherical solids travelling in one 'body'. Such a group was recorded as one solid having one solid identification code, although the code included details of the exact conglomeration.

This was only done if the group in question was considered to be acting as one solid. If, on the other hand, such stools were widely spaced, they were then recorded as separate solids. In the same vein, any waste material moving in one body was considered to be a single solid. Thus, what may have been several separate solids, interwoven and moving together, would have been classified as one solid. In some cases faecal material was combined with toilet/tissue-paper in this way. Such solids are referred to hereafter as faecal/tissue solids. The occurrence of a dense cloud of diarrhoea was recorded as a single and separate solid, unless the cloud merely engulfed some other solid, in which case it was recorded as part and parcel of that other solid.

As previously mentioned, a visual description was recorded of each and every solid discharged in all monitored single flushes. The six number code was developed, as presented in Figure 8/13, to reduce each solid description to a standard form, translatable at a glance and manageable to a computer. The material composition of each solid was obviously the easiest data to collect, but an attempt was made to record as comprehensive a description of each solid as possible in the manner outlined below:

The length and diameter were recorded for each faecal solid, except when such a solid consisted of numerous small and separate solids in close proximity to one another, being transported broadly speaking as one solid, in which case estimates of the number and average size of the constituent segments were made. For such 'cluster' faecal solids, the constituent segments were considered to be spherical, a three dimensional diameter being recorded in place of a length and two dimensional diameter. It had been noted, during initial observations, that a proportion of faecal solids were transported high in the carrying water, virtually avoiding all contact with pipe walls. Despite the reasonable possibility that this phenomenon was a function of flush content and drain geometry, rather than the result of a distinct property of the particular solid, such occurrences were recorded for later analysis.

Obviously, variations in length of toilet/tissue-paper solids could reasonably well be estimated, as with faecal solids, although not to any great accuracy, at least sufficient to identify significant differences between solids. As regards the width of toilet/tissue-paper solids, variations between solids were extremely small in proportion to the basic solid width, and could therefore not be distinguished simply by observation. Such solids, by and large, took up the width available between pipe walls as restricted by the depth of carrying water. Variations in the thickness of toilet/tissue-paper solids were also relatively small in strictly dimensional terms, but in proportion to mean solid thickness were quite considerable. Some solids consisted merely of a single sheet of paper, others of tens of sheets. Some measure of thickness was therefore highly desirable. However, the toilet/tissue-paper solids observed displayed widely varying degrees of 'compaction', thus rendering a purely linear measurement of thickness invalid. Toilet/tissue-paper solids were therefore evaluated for thickness subjectively by observation, and classed as one of five possible alternatives ranging from very thin to very thick. Despite this subjective assessment, as all such observations were performed and recorded by the same operator, the data collected was considered acceptable for comparative purposes.

Various other descriptive categories were incorporated into the code to deal with other solid types, such as tampons, sanitary towels, and composite 'faecal/tissue' solids. These additions are self-explanatory, as included in Figure 8/13, and need no further clarification here. It should be noted that all visual estimates of solid length and diameter were recorded in imperial units. This was contrary to S.I. unit requirements, but essential to avoid unnecessary error, the 'on site' assistant- a retired technician- not being practiced in metric estimation.

Analyses of the proportions of various material types of solids which occurred, either in particular flush types or at particular drain geometries, are based upon accurate information; a solid either was or was not of a certain material. Presentation of such information to two or three decimal places is therefore not unacceptable.

However, analyses having regard to solid dimensions are a different matter; solid widths were estimated to the nearest quarter of an inch; solid lengths were estimated to the nearest inch, if less than 10" long, or to the nearest three inch interval if larger. That precise measurements could not be taken obviously resulted in considerable loss of accuracy, compounded by the fact that, even with such broad groupings, errors in classification were inevitable. Analyses showed that, in all cases, there were markedly more observations recorded as 4", 6", or 8" lengths, as opposed to 3", 5", 7" or 9" lengths. That this was actually the case is inconceivable, but rather shows the subconscious preference of the operator for even numbers, and indicates that these lengths should have been estimated to the nearest 2" interval under the prevailing difficult conditions. In order to compare typical dimensions between different groups of solids, either in different types of flush or under different drain geometry layouts (for purposes of either evaluating different types of loads, or ensuring that loads were sufficiently similar between tests to warrant that measured deviations, in transport characteristics, were due to differences in drain geometry), analyses of such dimensional information, despite unquestionable inaccuracies, was essential. It was considered acceptable to calculate means and standard deviations to two or three decimal places simply for purposes of comparison, although the errors involved precluded acceptance of such data as numerically accurate.

10.2.2.2 Distinctive Flush Types.

Monitored discharges were considered, as regards flush content and therefore user activity, to fall into three distinct and separate groups;

- a) Flushes containing no solids whatsoever,
(referred to hereafter as 'water only' flushes).
- b) Flushes containing non-faecal material only,
(referred to hereafter as 'non-faecal' flushes).
- c) Flushes containing at least some faecal material,
(referred to hereafter as 'faecal' flushes).

Water only flushes were assumed to be the result of urination. Flushes containing non-faecal material only were assumed to have originated either from urination, or from some other personal hygiene activity. Flushes containing faecal material were obviously the result of defecation. With respect to the number of solids discharged in each flush, Figure 10/22 presents data concerning the proportions of each category of flush observed.

It can be seen from Figure 10/22, that only 9.0% of monitored 'single' flushes at the female facility contained any faecal material. 'Water only' flushes, which can only improve the self-cleansing ability of a system, accounted for 32.7% of the monitored discharges, and the remaining 58.3% contained non-faecal material only. Of those women using a W.C. for purposes other than defecation, it would appear that 64.1% employed toilet tissue paper, presumably either to clean the appliance seat or for bodily cleansing purposes. Thus, only 67.3% of flushes were 'loaded', and of these 'loaded' flushes 86.6% contained non-faecal material only.

In comparison, and also as shown in Figure 10/22, 41.3% of monitored single flushes at the male facility were 'faecal', 22.6% were 'non-faecal', and 36.1% were 'water only'. However, as discussed in Sections 10.1.2.5 and 10.1.2.6, considerably more males employed a W.C. for the purpose of urination, at this particular facility, than would have been the case at an installation which included adequate and socially acceptable urinal provision. It is suggested, in Section 10.1.2.6, that at an adequately designed male facility 73.7% of W.C. usage would result in defecation. The remaining 26.3%, it is suggested, would be the result of activities other than defecation, these possible activities being assessed as follows: some arrivals, requiring only to urinate, will use a W.C. to this end irrespective of the standard of urinal provision; some arrivals will neither urinate or defecate, but will use a W.C. cubicle for some other personal hygiene activity; some arrivals may intend to defecate but may prove to be constipated.

It is not possible, however, from the results of this work, to predict what proportion of those 26.3% of flushes, resulting from activities other than defecation, would be 'non-faecal', as opposed to 'water only', at a 'normal' male facility. Of the flushes monitored, only 56.0% would have occurred had there been adequate urinal provision, yet 63.9% contained either faecal and/or non-faecal solids. Thus, it is possible, that all normal W.C. usage resulted in the deposition of solid material, and that 18.0%, $((63.9-56.0)/(100.0-56.0))$, of the flushes resulting from diversion from urinals contained non-faecal material. On the other hand, it is also possible that all those flushes resulting from normal usage, which did not contain faecal material, were 'water only', and that 51.5% $(22.6/44.0)$, of the flushes resulting by diversion from urinals contained non-faecal material. Any balance, between these two extreme possibilities, could have been the case.

Consideration as to the possible activities which could have resulted in the occurrence of 'non-faecal' flushes does not clarify this situation. It is not unreasonable that a proportion, of those W.C. users diverted from urinals, disposed of some non-faecal material via the W.C.. It remains a matter for conjecture as to the exact usage to which such tissues were applied, but there are many possibilities; to avoid personal contact in lifting the seat; for bodily cleansing purposes; in place of a handkerchief; retained since some earlier usage and simply disposed of at this convenient point, (pockets emptied etc.). It is also not unreasonable that a proportion of the 26.3% of normal usage which did not result in defecation, did result in the disposal of some non-faecal material. Again, there are many possibilities as to the exact usage to which such 'tissues' may have been applied; for bodily cleansing purposes, either after urination or after attempted defecation; to clean the seat prior to any sedentary activity.

One suggestion for the occurrence of 'non faecal' flushes was that some people, intending to defecate, first cleaned the appliance seat with toilet/tissue-paper, which paper was then flushed away prior to defecation.

If this pattern of behaviour had been significantly widespread, serious doubts would have been raised as to the validity of previous calculations concerning the amount of diversion from urinals at this particular facility. However, of all those flushes which occurred immediately prior to 'faecal' flushes from the same W.C., the proportion which were 'non-faecal' was no greater than the proportion of all monitored male flushes which were non-faecal. This pattern of behaviour could not, therefore, have been a significant factor.

In the light of the above, the estimate is upheld that, at a male facility incorporating adequate and socially acceptable urinal provision, 73.7% of flushes would normally contain faecal material. However, due to the non-typical usage, of this particular facility, caused by inadequate urinal provision, it was not possible to evaluate the proportion of 'water only' to 'non-faecal' flushes which might be expected at such a 'normal' facility. It can therefore only be recommended, for a worst case analysis, that it be assumed no 'water only' flushes occur. Figure 10/27 presents a graphical summary of the proportional rate of occurrence of distinctive flush types, as monitored at the male and female facilities, and as predicted for a 'normal' male facility.

10.2.2.3 Constituent Solids - Number and Material Type.

Figure 10/28 presents a summary of the mean numbers of particular and total solids per flush, for the different types of flush at the different facilities and gradients. This table shows that, on average and at each facility and gradient, 'faecal' flushes contained more than twice as many solids as 'non-faecal' flushes. It also shows that for similar types of flush, on average and at the same gradient, those at the male facility, contained more solids than those at the female facility. At a gradient of 1:150, the average 'faecal' flush at the male facility contained 30.0% more solids, (32.5% more faecal solids, 31.8% more faecal/tissue solids, and 25.6% more non-faecal solids), and the average 'non-faecal' flush contained 31.2% more solids, than did the comparable female flushes at the same gradient. However, the most surprising aspect, of Figure 10/28, is that it suggests gradient as having affected the number of solids per flush, at least as regards 'faecal' flushes. Since this is obviously not possible, it can only be concluded that the method of data collection was in some way at fault.

This result is more fully discussed later in this section. Accepting that results gained at different gradients must be considered separately, the table below presents data concerning the proportional rate of occurrence of distinctive solid types as constituents in 'faecal' flushes.

		Female facility		Male facility
		Gradient 1:150	Gradient 1:200	Gradient 1:150
Proportional number of distinctive solid types as constituents in 'faecal' flushes.	Faecal solids.	59.73%	60.60%	60.89%
	Faecal/tissue solids.	4.36%	3.64%	4.43%
	Non-faecal solids	35.91%	35.76%	34.68%

Clearly, although the actual number of solids varied according to facility and gradient, the proportional rate of occurrence of particular solid types remained relatively constant. However, the results presented in Figures 10/29 and 10/30 suggest, that, irrespective of facility or gradient, the proportional rate of occurrence of particular solid types, in 'faecal' flushes, varied according to the total number of solids per flush. Graphical presentation of this data, in Figures 10/31, 10/32 and 10/33, confirmed such a relationship, the proportion of faecal solids per flush increasing with increase in the total number of solids per flush, although considerable deviations seem to have occurred from the relationship for those flushes containing the most solids. Nonetheless, scrutiny of Figures 10/29 and 10/30 shows that extremely few flushes were recorded containing more than six separate solids, too few to represent sufficient sample size for such analyses.

It had been presupposed, that the number and type of particular solids, in particular flush types, would vary according to customer behavioural patterns and W.C. discharge characteristics, the former determining the amount and composition of waste deposits, and the latter re-arranging the material into separate solids. However, as previously stated, Figure 10/28 suggests gradient to have affected the average number of particular solid types per flush, at least as regards 'faecal' flushes.

A basic statistical test, based upon the mean, variance and size of each sample, was employed to compare the mean number of solids discharged per 'faecal' flush, firstly between the different facilities but at the same gradient, and secondly between the different gradients tested at the female facility. Both comparisons concluded the differences to be 'definitely significant'. Thus, the observed differences must be taken as real differences, and not as the result of random variation. In fact, gradient could not have altered the number of solids per flush, it is only possible that, due to the effects of varying gradient, solids were classified differently. In order to examine this possibility further, the different material types of waste solid must be considered separately.

At the male facility, observations of flush content were conducted immediately adjacent to the W.C. outlets. At the female facility, due to the particularly dense arrangement of other building service hardware in the area beneath the associated W.C.s, observations were conducted at some distance from the point of entry to the pipework. It is therefore possible that, at the female facility and at the flatter gradient, solids tended to remain separate during transportation, but that at gradient 1:150 solids tended more often to 'close together' and travel as one solid. The remote observation point would have allowed sufficient time for this to have occurred prior to inspection, and if the particular solids adjacent to one another were both toilet/tissue-paper solids, due to the very nature of the material, the fact of their being separate would not always have been detectable. Thus, at the steeper gradient, the number of non-faecal solids recorded would have been proportionally less, but this would have resulted in a direct relationship between the mean number of toilet/tissue-paper solids per flush and the mean length of such solids. In examining toilet/tissue paper solid geometry, in Section 10.2.2.4, data is therefore presented in terms of the mean length of such material per average flush, being the product of the mean number of solids per flush multiplied by the mean length of such solids, thus eliminating the inconsistency outlined in the method of classification. It is interesting to note that the phenomenon outlined appears not to have affected the mean number of solids per 'non-faecal' flush, the means recorded being virtually identical for the different gradients at the female facility.

This is only as would have been expected, as over 80% of such 'non-faecal' flushes contained one solid only, and could therefore not have been susceptible to solid 'combination'.

In consideration of the difference in the mean number of faecal solids recorded, at the different gradients at the female facility, although it follows, from the previous argument, that these solids also would have tended to 'close together' at the steeper gradient, this would not have resulted in two such solids being considered as one to any significant degree. Faecal solids tended to retain their own shape and form, being much less malleable under hydraulic forces than toilet/tissue-paper solids, and would have been recognised as separate even when in close contact with other such solids. However, as previously outlined in Section 10.2.2.1, when many small faecal solids were considered to be acting in one 'body', they were classified as one solid. This being the case, as well as less faecal solids per 'faecal' flush being recorded at the steeper gradient, it would be expected that a greater proportion of these would have been 'cluster' solids, and that for the remaining individual faecal solids the average size would be larger, as only small solids were classified in 'clusters'. It can be seen from Figures 10/28 and 10/35, that the recorded data did indeed conform to each of these expected conditions. In order to evaluate real differences between facilities, as regards the faecal content of flushes, data is therefore presented, in Section 10.2.2.4, in terms of the volume of faecal material per flush.

Of the solids previously referred to as non-faecal, the vast majority, 96.3% at the female facility and 96.5% at the male facility, consisted of toilet/tissue-paper. Figure 10/34 details the exact material composition of all observed solids, in terms of the number of each observed as separate solids, and as such includes details of those non-faecal solids which were not toilet/tissue-paper, these being referred to hereafter as 'rogue' solids. As regards the female facility, 'rogue' solids constituted 0.5% of total solid content in 'faecal' flushes, and 4.0% of total solid content in 'non-faecal' flushes, the corresponding figures for the male facility being 0.4% and 7.2% respectively. From this, and the data presented in Figure 10/28, it can be seen that rogue solids were much less of a problem in 'faecal' flushes.

Considering the total number of 'rogue' solids observed, in relation to the total number of flushes received at each facility, it transpires that one 'rogue' solid was disposed of per 33.3 flushes at the female facility, and per 31.2 flushes at the male facility.

All 'rogue' solids must be considered as the result of misuse of facilities, general waste bins, sanitary towel disposal bags and specific bins for receipt of the same, having been provided, see Section 9.3.2. It can be seen, from Figure 10/34, that half of the 'rogue' solids disposed of at the female facility were sanitary towels, the next largest component being tampons and their associated packaging. At the male facility, 87.5% of 'rogue' solids were handtowels, as far as it was possible to determine, identical to those dispensed at the facility, see Section 9.3.2. Such solids as sanitary towels, tampons and handtowels, more consistently retained their original shape during transportation, being less malleable under the prevailing hydraulic forces, than for instance did toilet/tissue-paper waste solids. Other articles such as wrappers, whether confectionery, cellophane or brown paper, displayed poor travel characteristics due to adhesion with the pipe walls. However, such wrappers were all of insignificant size, and therefore caused no discernable impediment to successive waste solids.

The introduction of various obscure and abnormal solids to drainage systems is widely considered as a major cause of blockage formation. However, as can be seen, the proportion of abnormal solids encountered during this study was relatively small, and of these none were such as to cause particular problems. It can only be concluded, that the introduction of unmanageable 'rogue' solids into the drainage system, via the W.C., is a relatively rare occurrence. The only measure available, of the abnormality of such an occurrence, is that the total number of flushes observed in detail in this study, not one of which contained such an unmanageable 'rogue' solid, would equate to 1.8 weeks of continuous 'around the clock' usage at the female facility, plus 2.4 weeks of continuous 'around the clock' usage at the male facility, see Section 10.1.

As already mentioned, of those solids previously referred to as non-faecal, the vast majority consisted of toilet/tissue-paper. The paper provided was of the greaseproof type, but a significant proportion of the toilet/tissue-paper solids observed in the service pipework were not white, but were variously coloured. Obviously, some W.C. users were providing their own toilet/tissue-paper. As it was not possible to distinguish between the greaseproof and other white paper when in transit, a true estimate of the extent of this behaviour was not attainable. However, 6.1% of toilet/tissue-paper solids at the female facility were identified as being variously coloured, but not white, as were 1.1% of such solids at the male facility, and this provides some measure of the phenomenon. It must be concluded, that objection to the use of 'greaseproof' paper is widespread, particularly amongst women. Checks were regularly conducted, during all site monitoring periods, to ensure sufficient provision of toilet/tissue-paper at each appliance. On no occasion was the supply found to be inadequate, thus precluding the possibility, that inadequate provision was a contributory factor in the use of other papers.

10.2.2.4 Constituent Solids - Load Assessment.

The data concerning waste solid shape and geometry, in conjunction with the data regarding the number and material type of such solids, was originally intended to allow comparison of average waste loads, between both the different flush types and the different facilities. Such an assessment as presented below for the faecal and toilet/tissue-paper components of flush loads, which together accounted for 97.5% of all observed solids, insufficient numbers of other material types of solid having been observed to render comparisons for other such components statistically significant.

As previously explained in Section 10.2.2.3, due to solid combination and the resulting misclassification, it was not considered valid to investigate either the number of toilet/tissue-paper solids per flush, or the length of such solids, independently of one another.

Such solids are therefore considered in terms of the mean length of material per flush, being the product of the two variables discussed, as in the table below compiled from Figures 10/28 and 10/36. The mean number of toilet/tissue-paper solids per flush, as presented in this table, also includes those such solids which carried faecal material, (faecal/tissue solids).

			Toilet/tissue-paper waste.		
			Mean length of individual solids (mm)	Mean number of solids per flush	Mean length of material per flush (mm)
'faecal' flushes	female	1:150	235	1.178	277
	facility	1:200	191	1.481	283
	male facility (1:150)		191	1.485	284
'non-faecal' flushes.	female	1:150	184	1.152	212
	facility	1:200	199	1.196	238
	male facility (1:150)		171	1.487	254

In attempting to identify any real differences in flush content, from the data presented in this table, it is assumed, for the moment, that all other dimensionable variables were equal overall. Thus qualified, the table clearly indicates that, in all cases, the average 'faecal' flush contained more toilet/tissue material than did the average 'non-faecal' flush, although the proportional difference was smaller at the male facility. Consideration of the female facility shows that, on average and for both 'faecal' and 'non-faecal' flushes, the total length of toilet/tissue material per flush was greater at the flatter gradient. Obviously, as many more solids were observed than statistical analysis would require to obtain a close approximation to the true mean flush content, there could not have been any real difference, for similar flush types at the same facility, in the average amount of toilet/tissue material per flush between tests.

It must therefore be concluded that, at the steeper gradient, toilet/tissue-paper solids travelled in a more compacted state, but that, with flatter gradient, these solids expanded in response to a reduction in the hydraulic forces by which they were transported. This having been the case, comparisons between the different facilities can only be valid for those tests conducted at similar gradient. Also, as the dimensional adjustment of such solids must have been gradual, the descriptive data recorded must have varied with the distance of the observation point from the point of entry to the pipework. As previously stated, in Section 10.2.2.3, the observation point, for tests at the male facility, was much closer to the point of entry to the pipework than was the observation point at the female facility. Thus, the results from the different facilities are not truly comparable. However, for tests at the same gradient, the recorded results suggest the amount of toilet/tissue material per 'non-faecal' flush to be considerably greater at the male facility than at the female, and although the proportional difference recorded may have been distorted due to the phenomenon discussed, it could not solely be the result of this phenomenon. The table also suggests 'faecal' flushes to have contained more toilet/tissue material at the male facility than at the female for similar gradient, but in this case the observed difference was considerably smaller, and can only be considered as suggesting, as opposed to proving, a real difference.

Evaluation of the mean length of toilet/tissue-paper material per flush, as outlined above, has pre-supposed the observed differences to reflect variations in the amount of material present in each case, thus assuming other dimensional variables to have been equal between tests. As previously stated in Section 10.2.2.1, width variations of toilet/tissue-paper solids were extremely small in proportion to basic solid width. Although it may or may not have been the case, that small variations in solid width were vital as regards the resulting transport characteristics, the fact of very small variations must suggest width to be relatively unimportant in estimating variations in the amount of the material present per flush. As regards the thickness of toilet/tissue-paper solids, it had not been expected that any real difference would occur between tests, for although considerable variations were observed from one solid to the next, it was expected that these would average out, and that any real increase in the mean quantity of material present per test would be solely detectable by an overall increase in the length of such solids.

However, estimates were made as to the thickness of toilet/tissue-paper solids, but, as mentioned in Section 10.2.2.1, these were subjective rather than purely linear estimates. This approach was adopted in an attempt to better assess the true thickness of the material, the intention having been to eliminate the degree of solid compaction from the estimation. Figure 10/37 presents a summary of the information recorded, but, due to the non-linear assessment, this does not easily lend itself to comparative analysis. Purely in order to achieve such a comparative analysis, scalar values were applied, of from one to five respectively, to represent the five classifications, i.e. very thin = 1, thin = 2, medium = 3, etc. In this way, scalar and non-dimensional values were calculated, for the means and standard deviations of thickness, as in the table below;

			Mean thickness	Standard deviation
'faecal' flushes	female	1:150	3.210	0.768
	facility	1:200	3.320	0.519
	male facility	(1:150)	3.086	0.564
'non-faecal' flushes	female	1:150	3.197	0.759
	facility	1:200	3.303	0.751
	male facility	(1:150)	3.042	0.807

The variations between samples, as displayed in the table, may seem random and rather small. However, comparisons of the mean toilet/tissue-paper solid thickness, between 'faecal' and 'non-faecal' flushes, and for tests at the same facility and gradient, display much closer levels of agreement than do similar comparisons between tests at different facilities and gradients. In fact, statistical analysis confirmed the type of carrying flush not to have been a significant factor, but as expected, suggested 'probable significance' in the variations displayed with changes of facility and gradient. It is again apparent, that the information recorded was not independent of gradient. Consideration of the female facility shows that, the same for thickness as already found for length, at the flatter gradient toilet/tissue-paper solids expanded in response to the reduced hydraulic forces prevailing.

That the mean thickness recorded at the male facility, at gradient 1:150, was smaller than that recorded at the female facility, at the same gradient, was again due to the more remote observation point at the female facility. It is suggested, that toilet/tissue-paper solids were most compact at evacuation from the W.C., and that they expanded during transit, the rate of expansion having been limited according to the particular gradient.

Thus, the variations in observed thickness appear to reflect, not differences in the amount of material present, but the response of this malleable material to the prevailing environment, and this despite the fact, that subjective estimation had been adopted in order to eliminate such factors. It follows, from this explanation, that if the mean quantity of toilet/tissue-paper material per flush had been identical at both facilities, then at the male facility the recorded mean length would have been smaller, due to the less remote observation point here, for tests at the same gradient. Although earlier results suggested male flushes, on average, to have contained greater lengths of toilet/tissue material than female flushes, due to more expansion having occurred prior to the observation point at the female facility, it now appears that these differences were underestimated. Assuming the proportional differences displayed, between the estimates of mean solid thickness for different tests, solely to represent varying degrees of compaction, then correction factors calculated from this data can be applied, to the data concerning toilet/tissue material lengths, to equalise the effects of different gradients and observation points. Continuing to assume increased quantities of material present to have only resulted in greater mean lengths of material per flush, the table below presents two estimates of the proportional quantities of toilet/tissue-paper material contained, on average, in the different flush types and at the different facilities. The first estimate takes no account of the remoteness of the observation points, from the points of entry to the pipework, nor, therefore, of the different states of solid compaction.

The second estimate was arrived at by the application of correction factors to the first estimate, these factors having been calculated from the solid thickness data as discussed above.

		Quantity of toilet/tissue material per average flush, (expressed as a proportion of the greatest mean quantity)	
		1st Estimate	2nd Estimate (corrected)
'faecal' flushes	female facility	0.976	0.945
	male facility	1.000	1.000
'non-faecal' flushes	female facility	0.749	0.618
	male facility	0.897	0.897

However, such corrective calculations assume, either no limit to the degree of compaction or expansion possible, or at least that any such limits were not reached. A further inconsistency was that no difference was displayed in the expansion rates for thickness between the different flush types, whereas the expansion rates for length varied considerably, that for toilet/tissue solids in 'non-faecal' flushes being the greater. The corrected results, are, therefore, only a rough estimate.

It has become apparent, that toilet/tissue paper solids adjusted their geometric form, or state of compaction, inversely to the prevailing level of hydraulic forces. As these forces reduced, with distance from the point of entry to the pipework, such shape adjustment must have been continuous within certain limits. Thus, as previously outlined, gradient also directly affected the shape of these solids. Solid geometry is known to affect solid transport characteristics, and as the solid transport equation formulated by Wakelin (1978) was based upon solids of fixed geometric form, the recorded velocities may be expected to diverge somewhat from this relationship. Before moving on from discussion of toilet/tissue-paper solids, the information presented in Figure 10/38 merits some attention.

Although sanitary towels, in laboratory tests, tended to become 'wedge shaped' during transit, this was obviously not the case for toilet/tissue-paper solids observed 'on site'. Approximately 75% of all such solids were flat. However, from consideration of the data presented in Figure 10/38, and bearing in mind the different observation points and gradients, it is apparent that shape varied according to the state of compaction of the observed solid. The tendency was for solids to appear flat when most compacted, to become more irregular after limited expansion, but with further expansion again to appear flat. That this was the case does not seem unreasonable, as the process could be likened to the extension of a concertina.

As previously explained in Section 10.2.2.3, due to inconsistencies in the method of solid classification, resulting from changes of gradient, it was considered necessary to assess faecal loads in terms of the mean volume of such material contained per 'faecal' flush. Although faecal solids may have been susceptible to 'break up' or limited reshaping, due to the prevailing hydraulic forces, the nature of the material ensures the total volume to have remained unchanged by gradient or distance travelled. However, having calculated the volume of faecal material contained in each and every 'faecal' flush, from the geometric estimates gained by observation, it appeared that, on average, flushes at the female facility contained less faecal material at gradient 1:150 than at gradient 1:200. Statistical analysis confirmed a 'definitely' significant difference between these two samples. As more than sufficient flushes had been monitored to attain a good approximation to the true mean flush content, it was not possible that the difference displayed could reflect reality.

To further investigate possible causes of this inconsistency, 'faecal' flushes were examined, in groups containing approximately twenty flushes each, according to the order in which they were monitored. The mean and standard deviation of volume faecal content per flush, were calculated for each group, and these results are presented in Figure 10/39.

From this information, and the graphical presentation of the means of each group in Figure 10/40, a clear pattern emerges. From an initial low volume, the means recorded steadily increased, with successive flushes, until a more consistent 'plateau' was reached. It is suggested, that this pattern represents a 'learning curve', which steadied only when the assisting operator had become practiced at such estimation. Thus, virtually all of the faecal volume data, collected at gradient 1.150 at the female facility, had to be considered invalid for comparative purposes. The remaining data indicates the average 'faecal' flush at the female facility to have contained 157.1 c.c. of faecal material, the comparative figure for the male facility being 166.6 c.c.. Although these values seem to suggest male 'faecal' flushes on average to have contained a 6% greater load than was the case at the female facility, statistical analysis of the means, standard deviations and sizes of each sample, showed the apparent difference not to be significant. No difference has therefore been proven, between the average volumes of male and female faecal loads, although the possibility remains that male loads could have been slightly greater.

As mentioned in Section 10.2.2.1, that precise measurements of solid geometry could not be taken ensured a certain loss of accuracy, thereby rendering results truly valid only for comparative purposes. However, it is interesting to note, that the estimates of mean faecal volume per flush, outlined above, correspond closely to the consensus findings of other researchers, as discussed in Section 5.1.2, concerning the faecal output of the normal healthy U.K./U.S. adult per 24 hour period. It is not meant to suggest, that these two variables should necessarily equate with one another, as the mean frequency of user defecation can not be assumed to be 24 hours, but, while lacking precise information, such an estimate would seem the most obvious possibility.

Although subject to minor inconsistencies in the method of solid classification, due to changes of gradient (as discussed in Section 10.2.2.3), Figure 10/35 presents details of the observed faecal material in terms of the size, shape and form of solids travelling independently.

It can be seen, from the data concerning the proportion of solids noted as, 'tending to float', bearing in mind the relative remoteness of observation points and the different gradients, that this did not relate to solid density, but merely reflected solid velocities, solids tending to ride higher in the water stream at the higher velocities. Figure 10/35 also suggests from 66 to 77% of faecal solids to have been separate and sizeable, as opposed to diarrheic or in 'clusters', according to facility and gradient, whereas the corresponding values, in terms of volume, ranged from 78% to 81%. One final point of interest, from the faecal volume calculations, is that 4.7% of all faecal material was carried in 'faecal/tissue' solids.

10.2.3 Solid Deposition.

A complete analysis of solid deposition, based upon the exact position of each stoppage, would only be truly valid if, within the available length of monitored pipework, each and every solid had been deposited. Clearly, as the facilities studied were integral to a 'live' service, it was not feasible to reduce their efficiencies to such a low level. Thus, the usefulness of a complete study was severely limited. However, from a more basic study of solid deposition data, which takes no account of exact stoppage positions, comparisons can be made between various flushes as to their relative efficiency. This is achieved, for any particular arrangement of facility and pipe layout, by classifying the clearance of a solid through the associated length of monitored pipework as a success, and the deposition of a solid at any point within that same length as a failure. The proportion of failures, as compared to total solid content, provides the measure. Comparisons between such results gained at different facilities and gradients provide little useful information, as pipe geometry differed in each case, except to confirm the significance of conclusions which can separately be drawn from each arrangement of facility and gradient. The data presented for the female facility, at gradient 1:150, is less reliable than that presented for the other two arrangements. Due to the fact, that far fewer solids failed to clear the pipework at this layout, the results are more susceptible to random variations. This approach to solid deposition, although providing only limited quantitative information, allows good qualitative understanding of the interaction of flushes.

Figures 10/41 to 10/52 inclusive present the base data, concerning solid deposition, in terms of: the proportions of various types of flush which encountered and/or deposited stoppages; the proportions of various material types of solid which were deposited. The information is presented, in each case, in relation to the particular facility, gradient and total number of solids contained per flush at evacuation from the W.C.. The summary of waste solid deposition, as given in Figure 10/53, presents the data, concerning those flushes which encountered previous deposits, separately from that concerning those which did not. Also, solids contained per flush at evacuation are considered separately from previous deposits encountered.

As was only to be expected, at the female facility, a greater proportion of solids were deposited at gradient 1:200 than at gradient 1:150. However, that a greater proportion of solids were deposited at the male facility, at gradient 1:150, than at the female facility at the same gradient, despite the fact that the monitored pipework was somewhat shorter at the male facility, must in part be due to the larger individual loads at the male facility. The 92½° bend which was incorporated into the monitored pipework at the male facility, may also have been partly responsible.

Of those flushes which did not encounter previous stoppages, 'faecal' flushes deposited proportionally more of their waste content, in terms of number of solids, than did 'non-faecal' flushes. However, with regard to 'faecal' flushes only, the proportion of faecal solids deposited was much smaller than that of non-faecal solids deposited, which proportion was itself smaller, in the majority of cases, than that of faecal/tissue solids deposited. The overall level of deposition must reflect the average load per flush, but that faecal solids were less often deposited reflects the fact that such solids tended to the fore in all multi-solid flushes. As solids did not bypass one another, it was guaranteed that the first solid to enter the pipework, in any particular flush, would travel the greatest distance.

However, as the proportion of solids deposited, by those flushes which contained faecal material only, was less than the proportion of faecal solids deposited as contained in all 'faecal' flushes, it cannot be simply assumed that faecal solids were 'pushed along' by non-faecal solids. That faecal/tissue solids were most often deposited must reflect the large individual size of most such solids, each one in reality being a combination of at least two solids. The proportion of non-faecal solids deposited, as contained in 'faecal' flushes, was much greater than that of similar solids as contained in 'non-faecal' flushes. That this was so must reflect the considerable differences in mean load between the two types of flush, rather than simply the differences between the respective individual solids.

It can be seen that, on average and for comparative flushes recorded under identical conditions, those which encountered previous stoppages did themselves deposit a greater proportion of their own solid content than those which met no such impediment. The proportional increase in the number of deposits varied from case to case, as was only to be expected, this method of assessment serving rather as an indicator than a measure. Nonetheless, as can be seen from Figure 10/53, the differences were considerable in all cases. This phenomenon was compounded by the fact that, of the stoppages encountered, not all were cleared by the following flush. Although less likely to be deposited in the first place, faecal solids, once deposited, proved more difficult to clear than non-faecal solids. The explanation, for this apparent inconsistency, was obvious from 'on site' observations. The majority of solids in normal transit were partly 'pulled along' via 'shear' contact with the passing water. However, such forces alone were not normally sufficient to initiate motion in deposits encountered. Non-faecal solids, which in transit adjusted their width to the available space, on deposition, tended to 'dam' the pipe section against following water. With the arrival of a following flush, such deposits were literally 'pushed' back into action. Faecal solids, which better retained their original shape and form during transit, did not, on deposition, form any such impediment to following water.

Shear forces from the following flush were often insufficient to re-introduce motion, and such deposits were then bypassed. On the other hand, provided that such a faecal deposit were not too remote from the W.C., and that attenuation had not significantly eroded the momentum of the following flush, the impact of the leading wave considerably assisted the return to motion.

As the ability of a flush, to transport its own waste content, has been shown to deteriorate with increase in total load, so the efficiency of a flush, as regards the removal of deposits encountered, was inversely related to the size of the original load. On average 'water-only' flushes were most efficient, and 'faecal' flushes least efficient, at removing deposits.

The most significant information, to have emerged from this study of waste solid deposition, was that the occurrence of one stoppage increases the probability of a second, and thus, it must be assumed, increases the probability of escalation to a blockage. It follows, that above ground drainage should be designed to prevent the occurrence of stoppages above an agreed 'safe limit', the level of which must be determined. However, as each type of flush transported its own content, and removed solids encountered, with varying levels of efficiency, the proportional rate of occurrence of the different flush types must be a prime consideration in any such calculation.

10.3 Transport of 'Live' Waste Solids.

This work was intended to achieve three main aims; to confirm or negate the relevance of 'model solid' transport equations to 'in situ' waste loads; to allow for the calibration of future sterile 'model solid' experiments; to indicate an improved method for building drainage system design.

Facility usage patterns were evaluated, in some detail, in order to assess the normality of the facilities under consideration. In other words, to evaluate possible differences, concerning waste solid disposal, between these and other facilities. Basic information, concerning the proportional rate of occurrence of particular flush types, was an essential pre-requisite of such examination. Detailed examination of flush content achieved several goals; defined those 'waste loads' to which recorded velocities apply, thus allowing that, given some deviation between two 'test bodies' of results, the possibility of non-typical flush content could be assessed; identified certain differences between facilities, as regards average flush content, which would be expected to affect velocity results; allowed some insight into user behavioural patterns; served to clarify the causes of certain observed flow mechanisms. Solid deposition data was useful, in that it allowed some understanding of the interaction between separate flushes.

Those studies outlined in the preceding paragraph, although an essential part of this work, merely provide a solid base for the investigation. However, waste solid velocity data, viewed from this base, provides the key to successful achievement of the projects three main aims.

10.3.1 Flow Observations.

10.3.1.1 Positional Advantage of Faecal Solids.

That faecal solids tended to the fore, in mixed content 'faecal' flushes, has been mentioned on several previous occasions. This proved to be a significant factor, as detailed in sections 10.3.1.3 and 10.3.1.4, in the examination of faecal solid transport. Verification, of this positional advantage held by faecal solids, is therefore presented in figures 10/54 and 10/55. Simply in terms of the first and last solids discharged, per relevant flush, the table overleaf

gives a brief summary:

		Proportion of 'First solids' which were faecal.	Proportion of 'Last solids' which were faecal.
Mixed content 'faecal' flushes	Male Facility	91.8%	6.8%
	Female Facility	91.2%	17.9%
	Overall	91.5%	12.0%

10.3.1.2 Modulative Nature of 'Zone 2' Deceleration.

The effective shape of a waste solid varies during transport, in response to the particular forces prevailing, due to the flexible nature of the materials involved. From this fact, and the fact that solids are expelled from the W.C. in a fairly random fashion, it follows that the resultant transport will vary somewhat between different, but basically identical, solids. It was for this reason that, for each type of solid tested in the laboratory, approximately thirty flushes were monitored, and a statistically acceptable average characteristic was obtained. Other researchers, such as Marriott (1979), Swaffield (1975), Uujamhan (1978), Wakelin (1978) and Westaby (1979), also adopted this approach.

Velocity results representing the 'zone 2' flow regime, when averaged for a particular solid type and plotted against $\sqrt{L/G}$, suggest a reasonably uniform linear relationship. The impression is created that solid deceleration, in this zone, occurs under 'steady state' conditions. However, similar presentation, of a range of individual solid travel characteristics, demonstrates that this is not the case. Such individual characteristics are detailed in figures 10/56 and 10/57, for Fastidia Mini-pads and Johnson and Johnson Panty-shields respectively, as obtained from laboratory tests at a gradient of 1:80. As opposed to deceleration being 'steady', it appears that velocities oscillate both above and below the suggested linear relationship. Wave action through the carrying water, which can be attributed to the turbulent nature of W.C. discharge, is the only

reasonable explanation for this phenomenon. At gradient 1:80, for the particular towels mentioned, the oscillations vary in both direction and position. Thus, on computing average velocities, the oscillations tend to cancel one another, and linear profiles result.

Those Figures which display individual solid profiles, for any particular type of sanitary protection product, include examples of the extremes of performance monitored, both as regards the size and position of oscillations, and as regards the absolute values of velocity. Thus, each such Figure is intended to reflect the overall range of performance for a particular solid type. With this in mind, it can be seen that Johnson & Johnson Panty-shields were subject to much greater variation, one to another as regards absolute values of velocity, than were Fastidia Mini-pads, and as such are less appropriate for system calibration purposes.

Individual solid profiles, as recorded at gradient 1:150 at the male 'in-line' facility 'on-site', are presented in Figures 10/58 and 10/59 for Fastidia Mini-pads and Johnson & Johnson Panty-shields respectively. Similar results, as recorded at gradient 1:200 at the female 'in-line' facility 'on-site', are presented in Figures 10/60 and 10/61 respectively. The 'on-site' and laboratory installations were not identical, and velocity profiles for particular solid types varied accordingly. Calibration between systems is discussed in Section 10.3.2, but for the purpose in hand such variations are unimportant.

Oscillations, similar to those observed at gradient 1:80, can be seen to have occurred also at gradients 1:150 and 1:200. As was the case at gradient 1:80, oscillations decayed with distance from the W.C. and the modulative velocity profiles, displayed by different, but basically identical, solids, became further out of phase with one another as distance from the W.C. increased. However, the modulative velocity profiles, of different, but basically identical, solids in response to flattening gradient, tended to be less out of phase with one another than might otherwise have been the case. It is for this reason that, on computing average profiles, oscillations cancel one another less well at the shallower gradients. This is particularly noticeable for the initial, and more sizeable, oscillations. The

relevant averaged velocity profiles are presented in figures 10/105 and 10/106. The described phenomenon is less obvious from the velocity profiles of Johnson & Johnson Panty-shields, due to the fact that the performance of these towels, as previously mentioned, is generally less consistent.

Having determined the limits of the 'zone 2' flow regime for any particular test solid, those researchers mentioned earlier in this Section, who similarly computed 'average' velocity profiles, employed the method of 'least squares' to attain a line of 'best fit' through the relevant data points. It is in respect of this procedure, that the fact of oscillating deceleration raises the most significant question. On considering results gained at shallower gradients, where, on computation of average velocity profiles, initial oscillations in particular tend to reinforce rather than cancel one another, the method of 'least squares' is no longer appropriate. Deviations from the linear relationship are not random in such cases, but are strictly ordered in both direction and size. A certain amount of discretion is required in fitting a line through such data points.

The service pipework from W.C.3, at the female facility, provided the longest straight length of the in-situ test installations. It was therefore considered that observations, as to the mode of 'live' waste solid transport, could best be made from study of this arrangement. Individual solid velocity profiles are therefore presented in figures 10/62 and 10/63, as recorded at gradients 1:150 and 1:200 respectively, for a sample of toilet/tissue-paper solids, each of which was disposed of as the sole content of a 'single' flush from W.C.3. Absolute values of velocity, at any particular point, varied considerably between solids. This reflects the fact that the solids concerned varied widely as regards shape and size, the velocity profiles being commensurate to what might be expected for a range of variously sized sanitary towels. The more efficient toilet/tissue-paper solids most clearly display 'oscillating' deceleration in 'zone 2', the slower solids being less, if at all, effected. That this was the case is interesting, as maternity pads tested by Wakelin (1978) in the laboratory, which by comparison to such toilet/tissue-paper solids performed quite poorly, individually displayed pronounced 'oscillating'

deceleration, see Figure 10/64. Although awkward shape will considerably hamper solid transport, by and large the slower solids will be those of greater than average mass. Thus, as regards 'oscillating' deceleration in the 'zone 2' flow regime, it appears that lighter solids readily respond to wave action through the carrying water, but that for solids of greater mass such momentum transfers do not significantly effect velocity. However, solids of even greater mass, such as the maternity pad, begin to approach the limit discharge capability of the W.C.. This serves to increase the turbulent and random nature of W.C. discharge, and it is for this reason that, individually, such solids display very random 'oscillations' in deceleration.

As composition varied significantly from one 'live' waste solid to another, as did the resultant transport characteristics, 'oscillations' during 'zone 2' deceleration would be expected to cancel one another reasonably well, despite the shallow gradients involved, on computation of average velocity profiles. However, the very fact of such varied transport introduces other complications. At any particular gradient, as can be seen from Figures 10/62 and 10/63, the onset of 'zone 3' flow conditions occurred at less distance from the w.c. for the slower travelling solids. All zone limits similarly occurred at different points for different solids, the greater the variation in solid conformation, over the range of solids being considered together, the greater the positional variation of zone limits. In the laboratory experiments, as only identical solids were considered in any one test group, this phenomenon had insignificant effect. However, on computing average transport characteristics from site results, some point values of velocity must be calculated from the use of data representing more than one flow condition. Thus, average velocity profiles of 'on site' solids do not truly reflect the mode of individual solid transport, but confuse transitional areas between different flow regimes by suggesting them to be more gradual than is truly the case. The extent of such distortion will vary according to the particular group of solids concerned. This problem emphasises the need for careful consideration, when attempting to obtain the best linear 'fit' to such averaged 'zone 2' data points.

10.3.1.3 The Multi-Solid Flush - Interactive Mechanisms.

To this point, discussion of waste solid transport has been limited to the 'lone solid' situation. However, as outlined in some detail in Section 10.2, 'on-site' as many as nine separate and substantial solids were observed in a single flush. In this respect, a cluster of small solids travelling in close proximity to one another, the individual components of which could not separately be distinguished by the velocity monitoring equipment, was considered as one solid. When more than one solid occurred in a single flush, although the 'zone 2' flow regime associated with single solid transport prevailed, oscillations occurred around this basic profile due to the interaction of solids. For selected flushes, each of which contained two off toilet/tissue-paper solids, figures 10/65, 10/66 and 10/67, present individual solid velocity profiles. Some insight can be attained, from study of these, as to the numerous possible interactive occurrences.

The first example is of two comparable, and smaller than average, solids. Interaction was initiated when, in the early stages of solid travel, the trailing solid began to close on the leading solid. The depth of the intervening water stream increased, as the distance between the two solids decreased, thereby raising the head of water across the leading solid, and lowering that across the trailing solid. In this way the leading solid received extra propulsion, while the thrust of the trailing solid was momentarily checked. The depth of the intervening water stream then reduced, as the two solids moved further apart, at this point causing the head of water across the leading solid to be reduced, while that across the trailing solid was increased. Thus, as the trailing solid once more began to close on the leading solid, the cycle was renewed. This mechanism, referred to as the 'push me-pull you' effect, is classically displayed in example 1. It can be seen that, as regards the position and direction of 'oscillations' during 'zone 2' deceleration, the resultant velocity profiles mirror one another. Although this was not always the case, being a function of the overall distance between solids, it was the 'norm'. It can be seen that 'push me-pull you' oscillations, as compared to those associated with single solid deceleration, decayed much less rapidly. It is also apparent that, in absolute terms, the leading solid was most susceptible to velocity variations. For 'push me-pull you' oscillations, as for oscillations associated with single solid deceleration, it can only be concluded that the initiating wave actions were themselves the product of turbulent W.C. discharge.

The second example is of two larger than average solids, which, again in this case, were comparable as regards both shape and size. Reflecting the mass of these solids, the turbulence of w.c. discharge was insufficient to initiate the 'push me-pull you' effect, and as each solid decelerated at much the same rate, virtually no interaction occurred. Moving on to consider the case of a large solid preceded by a small solid, as in Example 3, initiation of the 'push me-pull you' effect cannot solely be attributed to the turbulence of w.c. discharge. In this situation the small solid decelerates less quickly than the large solid, and thereby increases the separation between solids. The depth of the intervening water stream is reduced, and the 'push me-pull you' cycle has commenced. Thus, the imbalance between solids initiates the effect. Due to its size, and relative position within the flush, the leading solid displays significant oscillations. The same factors cause the trailing solid to be hardly, if at all, effected. The opposite situation, of a small solid preceded by a large solid, is illustrated in Example 5. Under these circumstances both turbulent discharge, and the imbalance between the solids, ensure that oscillations are initiated. The leading solid is less susceptible to 'push me-pull you' forces, due to its considerable mass, but its relative position within the flush encourages a reaction. Similarly, although the trailing solid is more likely to react due to its smaller mass, its relative position within the flush dampens its response. Thus, both solids respond, but each to a limited degree only.

Example 4, in Figure 10/67, parallels Example 3 as regards the order and size of constituent solids. However, in Example 4 the trailing solid was deposited, due to its considerable mass, thus breaking the 'push me-pull you' cycle. The smaller leading solid continued for a short while, increasing the distance between the two solids, but causing the depth of the intervening water stream to be considerably reduced. The resultant water head adjustment across the trailing solid was insufficient to reintroduce motion, and yet not enough water by-passed this solid to prevent complete loss of head across the leading solid. The small solid, therefore, was also deposited. The opposite situation, illustrated by Example 6, reflects Example 5 as regards the order and relative size of constituent solids. In this case the larger leading solid, due to its size, was reduced to extremely slow progress and deposition was imminent. The trailing and smaller solid began to decelerate more quickly,

due to the increasing depth of the intervening water stream, as it closed on the leading solid. The increased depth did not stop the trailing solid on this occasion, but propelled the leading solid forward. No longer having the hindrance of deep water downstream, the trailing solid also increased its speed. However, the leading solid again slowed considerably, but this time the momentum of the trailing solid was insufficient to prevent deposition. Thus, the trailing solid was also deposited.

These examples of the 'push me-pull you' effect, as outlined above for flushes containing toilet/tissue-paper solids, were carefully chosen to demonstrate 'classic' situations. Although interaction occurred to some extent in all multi-solid flushes, not all were so completely ruled by the phenomenon. Factors determining the level and particular form of interaction, over and above those variables which govern single solid transport, include: number of solids per flush; initial solid separation distances; amounts of water ahead of, between, and behind solids at W.C. discharge; relative solid mass; relative solid blockage factors; relative solid deceleration rates. It can be seen, that the number of possible interactive occurrences are infinite. It can only be concluded that the transport of an individual solid, in any multi-solid flush, is dependent upon the character of the total waste load, both as regards the particular solids involved and the manner of their introduction to the discharge pipe.

With increased numbers of solids per flush, although the mode of interaction was identical to that outlined for two solid flushes, the resultant velocity profiles were further complicated. Profiles for a typical multi-solid 'non-faecal' flush are presented in Figure 10/68.

As the performance of an individual solid, in any multi-solid flush, was dependent upon the character of the total waste load, and as relatively few flushes occurred which contained faecal material only, an in-depth and separate examination of the mode of faecal solid transport was not an available option. However, it does seem that faecal solids responded to the 'push me-pull you' effect much as did toilet/tissue-paper solids. Lone faecal 'clusters' displayed particularly large velocity oscillations, as did small individual faeces, but amplitudes were reduced with increased solid mass. Figure 10/69 presents the solid velocity profiles of a multi-solid flush, which contained four substantial faecal solids,

and it can be seen that interaction occurred much as would have been expected had the four solids consisted of toilet/tissue-paper. Thus, interaction between faecal solids seems to compare well, at least in effect, with interaction between toilet/tissue-paper solids. However, values of blockage factor and mass, both of which factors are fundamental to the 'push me-pull you' effect, were on average widely at variance between faecal and toilet/tissue-paper solids. The values of both were generally much smaller for faecal solids. It was therefore inevitable that, between faecal and toilet/tissue-paper solids, the manifestation of interaction would vary somewhat from that observed between like solids.

Faecal solids, in the great majority of cases, occurred to the fore of mixed content 'faecal' flushes. As such they were positionally more prone to display interactive velocity variations. That individual faecal solids were generally of less mass, than individual toilet/tissue-paper solids, caused this response to be exaggerated. Solid velocity profiles, for the contents of one such 'faecal' flush, are presented in Figure 10/70. However, the extremes displayed in this case did not always occur, as is witnessed by the example presented in Figure 10/71, of four faeces followed by a single, and relatively small, toilet/tissue-paper solid. The relatively small blockage factor, presented by the average faecal solid, gave rise to one important distinction: water more easily by-passed such a solid. That this was the case considerably affected the interactive process between faecal and toilet/tissue-paper solids.

Due to their usual positional advantage, within mixed content 'faecal' flushes, faecal solids were less likely to be deposited than other solid types. Despite this, once having been deposited, faecal solids were less easily reintroduced to motion. Section 10.2.3 verifies these facts. All deposits, on the arrival of the leading wave of a following flush, received energy by momentum transfer at impact, although such forces were significantly reduced, by attenuation, with distance from the W.C.. Toilet/tissue-paper deposits, due both to significant blockage factor and non-rigid shape, tended physically to form barriers to prevent the bypass of water. In this way their reintroduction to motion was virtually assured. Faecal solids, in similar situation, tended simply to be bypassed. Although 'shear' contact with the passing water imparted some energy to such deposits, this was often insufficient to reintroduce motion. Other interactive occurrences, involving faecal solids, are

similarly explained. Interactive velocity variations displayed by faecal solids, excepting those resultant from direct impact with other solids, were caused largely by momentum transfers to or from, and 'shear' contact with, the surrounding water. Interactive effects between toilet/tissue-paper solids, on the other hand, were largely the result of water head potentials. Incidentally, as effective water-head potentials were not normally set up across faecal solids, collisions between faecal and other solids were not uncommon. Direct impact, between two toilet/tissue-paper solids, was an uncommon occurrence.

Consider the case, of a toilet/tissue-paper solid preceded by a faecal solid. As the trailing solid reaches the point of deposition, continuance of the faecal solid does not set up the water head required to 'pull' the trailing solid. Deposition of the trailing solid is therefore inevitable. After deposition, whereas a toilet/tissue-paper leading solid, which had set up a water head adjustment, would so have impeded its own progress, the faecal leading solid continues relatively unhindered by the preceding water.

The preceding example is, in fact, rather too clear cut. In reality, most faecal solids would have effected limited water head adjustments. But, by and large, and in comparison to those adjustments effected by toilet/tissue-paper solids, these would have been minimal. Solid velocity profiles, for the contents of a flush which, in principle, parallels the hypothetical example outlined, are presented in Figure 10/72, although in this case three faecal solids preceded the toilet/tissue-paper solid. All three faecal solids decelerated drastically, held by the 'push me-pull you' effect, as the trailing solid approached 'zone 3' flow conditions. It is arguable as to whether an effective 'pull' was exerted upon the trailing solid, as its steady progress for a short distance could be attributed to normal 'zone 3' flow mechanisms. The largest faecal solid, which immediately preceded the toilet/tissue-paper solid, proved unable to break from the 'push me-pull you' cycle, and therefore, shortly after deposition of the trailing solid, was itself deposited. However, after their initial deceleration, the leading two faecal solids were able to break from the 'cycle'. These solids having been freed from the influence of the trailing solids, achieved considerable velocity regain. It is arguable that their progress, thenceforth, was more successful than it would have been had the depositions not occurred. Obviously, in

this respect, the ability of trailing water to by-pass the toilet/tissue-paper deposit was not unimportant.

An example of exactly the opposite situation, a flush containing one toilet/tissue-paper solid followed by three faecal solids, is presented in Figure 10/73. In this case the trailing faecal solid was deposited, but its link to the 'push me-pull you' cycle was easily broken. Progress of the leading three solids continued, to all intents and purposes, unaffected by the deposition.

In summation of solid interaction, due to distinctive differences, as regards the importance of particular flow mechanisms to the interactive behaviour of different solid types, faecal solids are less strongly tied to the 'push me-pull you' cycle than are toilet/tissue-paper solids. None the less, on being transported along with, or in close proximity to, one or more averagely sized toilet/tissue-paper solids, the average faecal solid displays pronounced interactive velocity variations. At the same time, deceleration of the average toilet/tissue-paper solid remains relatively unaffected by faecal influence.

10.3.1.4 Re-evaluation of the 'Zone 3' Condition.

That the 'zone 2' flow regime, identified as fundamental to the transport of sterile 'model solids' in the laboratory environment, applies also to the mode of 'live' waste solid transport, can clearly be seen from the variety of velocity profiles presented earlier in this Section. This, despite the fact that individual solid velocity profiles display oscillations, both above and below the suggested linear relationship, due either to the turbulence of W.C. discharge, in the case of lone solids, or to interactive forces, in multi-solid flushes. As no solid velocity measurements were recorded, in the immediate vicinity of W.C. discharge, no conclusions could be drawn, from 'site' observations, as to the relevance of 'zone 1' flow conditions. However, in light of the observations regarding 'zone 2' flow conditions, as outlined in Section 10.3.1.2, a re-evaluation of 'zone 1' sterile solid data, as recorded by Uujamhan (1978) in his study of W.C. discharge geometry, raises serious question as to whether, or not, 'zone 1' exists at all, as a separate and distinct zone, (see section 10.3.2.3.2). With regard to the 'zone 3' flow condition, and its relevance to in situ waste loads, some clarification is required.

The velocity profiles, of four toilet/tissue-paper solids, are presented in Figure 10/74. Each of these solids was discharged from W.C.3 at the female facility, as the sole content of its own flush, during tests at gradient 1:200. The majority of such solids, prior to reaching the point of transition to 'zone 3' flow conditions, had cleared the available length of monitored pipework. However, the profiles presented are for solids which proved the exception to this rule. As can be seen, two of the solids survived the transition, and continued into typical 'zone 3' flow. The other two solids passed through no such transition, and simply continued to decelerate, in the manner of their 'zone 2' deceleration, to the point of deposition. In the length of monitored pipework available, and as previously mentioned, few such solids reached the transition point in question. It was therefore not possible, from such limited data, to obtain a reliable estimate of the proportional rate of occurrence of the latter described phenomenon. However, that several examples were recorded, in this 'zone 2' orientated study, must suggest such occurrences to be relatively frequent.

This failure to progress to the 'zone 3' condition, as displayed by some 'live' waste solids, could also have been displayed by some 'sterile' solids in the laboratory. To determine this point, Wakelin's (1978) results were carefully re-examined. One set of results proved to be of particular interest, as, within the available length of monitored pipework, each and every solid was deposited. This test, conducted at gradient 1:150, was comprised of thirty flushes. Each flush contained a single maternity pad. The resultant average velocity profile, as presented in Figure 10/75, displays a section of 'zone 3' dominated flow. However, from separate presentation of the individual component velocity profiles, a few of which are also given in Figure 10/75, it can be seen that two thirds of the solids involved were deposited prior to the onset of 'zone 3' flow conditions. In this respect, the average velocity profile is misleading. Thus, observations in the 'site' environment, concerning the 'zone 3' flow regime, do not contradict laboratory results. Rather, that particular study of the 'zone 3' regime was not the prime objective of earlier laboratory studies, led to some misconception of the motivating forces in this area.

During 'zone 2' deceleration, hydrostatic pressure, weight component and positive shear forces, all of which are continuously applied, serve to promote solid travel. However, the high velocity displayed by a solid, on entry to 'zone 2', which cannot simply be attributed to these continuous forces, is largely the result of the input process and previous momentum transfers from following water. 'Zone 2' comes to an end, only when this 'stored' energy, held by the solid, has been completely dispelled. The solid velocity has been so reduced, at this point, that it approaches that appropriate to the action of the continuously applied forces. The point overlooked by Wakelin (1978), is that these forces, alone, may prove insufficient to overcome the frictional resistance to motion, and that the 'appropriate velocity' mentioned could therefore be zero. Thus, those factors which affect the particular levels of either hydrostatic pressure, weight component, positive shear force, or resistance to motion, are all determinants in the possible promotion, and subsequent level, of 'zone 3' flow. The amount of water remaining to the rear of the solid, along with the mass and blockage factor of the particular solid, would be considered the most influential of these. The amount of water remaining to the rear of the solid, at the end of 'zone 2' flow, must itself be largely dependent upon the original position of the solid within the flush.

That blockage factor must now be considered fundamental, to the promotion of 'zone 3' flow conditions, must raise serious question as to the pertinence of the 'zone 3' flow regime to faecal solid transport. In comparison to the blockage factor of the average toilet/tissue-paper solid, that of the average faecal solid was considerably reduced. Thus, hydrostatic pressure, and therefore the total sum of forces acting to promote 'zone 3' flow, must also have been considerably reduced for faecal solids. This seems to suggest that, for the majority of faecal solids, deposition would occur at the point of termination of the 'zone 2' flow condition. However, that this was the case must remain supposition, as the results of this work were insufficient to allow categoric determination of the matter.

It would have been necessary, in order to arrive at such a determination, to examine flushes which contained single faecal solids only. To ensure that such solids progressed beyond the 'zone 2' condition, either a

longer section of pipework, or an even flatter gradient, would also have been required. As such flushes were extremely uncommon, and given the particular 'site' environment, this approach was not an available option. Of those few flushes which contained faecal material only, at the female facility, not one resulted in a deposit within the length of pipework available, nor did any of the solids contained therein progress beyond the 'zone 2' condition. Results from the male facility were of little use, in this respect, as the monitored pipework, as well as being relatively short, included a 92½° bend. As previously stated, the performance of an individual solid, in any multi-solid flush, was dependent upon the character of the total waste load. Information concerning mixed content 'faecal' flushes, for this reason, assisted little in the determination of this question. However, some such flushes were recorded, in which the trailing solid consisted solely of faecal material, which have partial relevance to this matter. Velocity profiles, for a selection of such trailing faecal solids, are presented in Figure 10/76. These profiles display straight-forward 'zone 2' deceleration, including the normal interactive velocity oscillations, although in each case the available pipework was completely traversed prior to the onset of 'zone 3' flow conditions. Most faecal solids, in this position, performed in similar fashion. The only four exceptions to this, out of all the recorded female flushes, are detailed in Figure 10/77. Each of these solids would have cleared the available pipework, prior to completion of the 'zone 2' condition, had it not been for the influence of preceding solids. Due to retrograde interactive mechanisms, which probably included direct collision, each of these solids was prematurely deprived of its 'stored' energy. Once having been reduced to dependence upon the 'zone 3' condition for continued transportation, albeit by such abnormal 'interference', each and every solid was deposited. Thus, the theoretical expectation, that the 'zone 3' flow condition would not normally be displayed by faecal solids, seems to be confirmed by the available data. However, relevant data was extremely limited, and can not therefore be considered conclusive.

That a significant proportion of toilet/tissue-paper solids were deposited, prior to the onset of 'zone 3' flow, emphasises the fundamental importance of the 'zone 2' condition to system design. That an even larger proportion of faecal solids may also have failed to progress beyond the 'zone 2' condition, is relatively less important. This is

the case, firstly because of the comparatively efficient travel characteristic displayed by the average faecal solid, and secondly because of the normal positional advantage held by the average faecal solid. This second point needs further explanation. As regards solid interaction, due both to generally greater mass, and increased blockage factor, toilet/tissue-paper solids were dominant over faecal solids. As solids did not by-pass one another, a dominant trailing solid ensured the progress of preceding solids. As the last solid of the flush, in approximately 88% of mixed content 'faecal' flushes, was of toilet/tissue-paper material, the importance of faecal transport was considerably reduced.

10.3.2 System Calibration.

The aims of this work relate primarily to the assessment of 'live' waste solids, as compared to the sterile model solids employed by earlier researchers. In this respect the problem had been viewed as one of 'solid' calibration, as opposed to one of 'system' calibration. In order to arrive at an empirical equation, which would allow for numerical assessment of the velocity variations resultant with change of gradient, Wakelin (1978) performed an extensive experimental program in a laboratory environment. To allow for numerical assessment of other velocity variations, resulting from other particular types of adjustment to system geometry, would require that other similar, complete and separate, appropriate investigations be performed.

The predetermined limits of this work, as regards both time and resources, in conjunction with the sheer magnitude of the task, precluded any possibility of extension to consider such geometric aspects. Thus, to allow for comparison between solid velocity measurements gained at the different installations, whether on site or in the laboratory, it was imperative that all variables, not specifically under investigation, be held constant throughout. The one planned exception to this, specifically the inclusion of a single gradient adjustment, was intended only to confirm or deny the applicability, to 'live' waste solids, of Wakelin's (1978) empirical equation for gradient. Unfortunately, as the laboratory based investigations were initiated well in advance of the site investigations, and as not one of the 'site' environments, which later became available, satisfactorily met with all of the necessary conditions, the desired continuity between installations proved unattainable.

As certain inconsistencies, with regard to system geometry, were unavoidable, and as this work could not be extended to allow for sufficiently detailed investigation of the parameters concerned, it was pre-determined that solid velocity results, gained at different installations, would not be directly comparable. However, the achievement of valuable qualitative information, despite this unfortunate predicament, remained a possible outcome of such comparison. Also, from detailed presentation of the relevant inconsistencies, it was intended that future researchers, having investigated the relevant parameters in sufficient detail, could employ the results of this work in the following ways; to re-evaluate the

applicability of their own theories; to extend the comparison between the male and female facilities; to match specific types of sanitary protection product, from the numerous variety tested in the laboratory, to specific 'live' waste loads.

With these facts in mind, this section details the particular discontinuities involved, attempts to assess the significance of each with respect to resultant velocity response, discusses previous studies relating to the relevant parameters, and describes an attempt at an empirical calibration between 'complete' installations (both 'on-site', and laboratory based).

10.3.2.1 Pipe Gradient.

Earlier research had suggested that solid deposition occurred at any point during 'zone 3' flow. Thus, accurate assessment, of the point of termination of 'zone 2' flow, was considered the primary concern of any waste solid transport investigation. The re-evaluation of 'zone 3' flow, as detailed in Section 10.3.1.4, suggests this conclusion to be considerably more valid than initially appreciated. To best achieve such an assessment, deposition of each and every solid, within the length of pipe-work available, would be required. Thus, gradient would be reduced to a minimum. However, as the 'in-site' installations had to function efficiently, being part of a 'live' system, this approach was not acceptable 'on-site'. Gradients of 1:150 and 1:200 were therefore employed, being as flat as possible, to maximise the proportion of 'zone 2' deceleration monitored, yet steep enough to avoid excessive solid deposition. The sheer amount of time required 'on-site', to gain a sufficient test body of results at any one gradient, precluded the possibility of more extensive gradient adjustment.

As outlined in Section 6, the transport characteristics, of a range of sanitary protection products, were investigated in the laboratory prior to the in-situ study. Due to the considerable number of different products involved, and the circumstances of funding, it was only possible to examine each product at a single gradient. Furthermore, to avoid the added complication of establishing a new gradient, prior to each product test, a gradient of 1:80 was maintained throughout. This particular gradient was selected, as it ensured reasonable travel distance for even the largest products, and yet still allowed that lighter solids complete the greater

portion of their transport cycle prior to system clearance. The intention had been, from the use of these various performance characteristics, to later select those products which best approximated to specific 'live waste' performances.

Thus it was not possible, either to employ the same gradients during all investigations, whether 'on-site' or in the laboratory, or to repeat each individual test at several different gradients. Although, theoretically, these discontinuities could be accounted for, at least as regards sterile 'model' solids, by the use of Wakelin's (1978) empirical equation for gradient, such an approach was not considered completely satisfactory. To illustrate this point, detailed examination of previous studies is required.

Figures 10/78, 10/79, 10/80 and 10/84, present average velocity profiles, achieved by other researchers which relate to sterile 'model' solids. These Figures are not directly comparable with one another, as each relates to its own specific test series. However, within each series, the only variable was the gradient at which results were achieved. The relevant researcher, in each case, calculated a linear estimate of 'zone 2' deceleration, based upon the results of the complete series of gradient tests, by the method of 'least squares'. Since this method was found not to be appropriate for such a purpose, as fully explained in Section 10.3.1.2, these estimates have not been graphically presented. In place of each, a re-evaluation of linear deceleration characteristic, arrived at from consideration of the modulative patterns displayed at each gradient, has been presented in each relevant Figure.

An estimate of linear deceleration characteristic, for any particular test arrangement, can be achieved from the averaged results of a single gradient test. However, such estimates vary somewhat, according to gradient employed, not only from one to another, but also from that characteristic which becomes apparent from superimposition of a complete series of gradient results. That this is the case can clearly be seen from each of the four Figures previously mentioned. Thus, it might be suggested that Wakelin's (1978) empirical equation for gradient is not truly applicable, but there is no real evidence to support such a position.

A more logical explanation is that the situation arises from insufficient data collection, and from the modulative nature of 'zone 2' deceleration.

The modulative deceleration patterns, displayed by individual solids, are not necessarily cancelled out in calculation of average velocity data points. In consequence, averaged data points do themselves display modulative variations around a linear characteristic. However, the number of points, at which individual solid performance was monitored, was strictly limited. Thus, in order to achieve an estimate of overall performance, whether for an individual solid, or for the average of a set of solids, an inter-connecting profile was intuitively constructed to superimpose upon the actual measured data points. As the various modulative deceleration patterns quite clearly vary according to situation, in respect of amplitude, frequency and rate of decay, such estimation must be subject to error from misinterpretation of data points. That individual 'on-site' measurements were of 'average velocity' over a one metre length, as opposed to being of 'point velocity' at a given location, must further serve to veil true modulative performance. As successful estimation, of a linear deceleration characteristic, is almost wholly dependent upon an appreciation of the overriding modulative pattern, and as this is less likely to be fully achieved when system clearance occurs prior to termination of 'zone 2' flow conditions, it becomes almost inevitable that individual gradient tests will suggest slightly different linear characteristics.

However, even assuming that realistic appreciation of overriding modulative patterns can be achieved, the accuracy, to which estimates of linear deceleration characteristic can be made, must deteriorate as modulative patterns become more pronounced. For any particular test arrangement, 'zone 2' modulative frequency tends to fluctuate during the course of solid travel. In consequence, the modulative velocity profiles displayed by different solids, discharged independently, become further out of step with one another as distance from the W.C. increases. This is the case whether or not solids under comparison are identical. As a result, in calculation of average velocity data-points, modulations tend to cancel one another much more effectively with increased distance from the W.C.. Thus, the typical average velocity profile displays sizeable modulations over the initial region, and almost insignificant modulations toward the later region, of 'zone 2'

deceleration. Modulative decay is suggested to be much more rapid than is actually the case for the component profiles. In attempting to fit a linear characteristic to such a modulative profile, it is therefore inevitable that the estimate of 'C3', (the theoretical value of $\sqrt{L/G}$, on the 'zone 2' linear characteristic, coincidental with velocity equal to zero), will be considerably more accurate than that of 'C1', (the theoretical velocity, on the 'zone 2' linear characteristic, coincidental with $\sqrt{L/G}$ equal to zero). This situation is particularly relevant to the results of this work, given the unavoidable discontinuities previously outlined.

Thus, a reasonable estimate of 'C3' may be obtained from the results of a single gradient test, provided, of course, that a sufficient length of 'zone 2' dominated pipework was monitored. However, even assuming correct interpretation of modulative performance, the achievement of as reliable an estimate of 'C1', and thereby the achievement of a similarly reliable estimate of 'C2', (the negative gradient of the 'zone 2' linear characteristic), can only be realised through the performance of a series of gradient tests.

In light of current understanding, and given that the external limits and restrictions, which applied to this study, could be avoided, the following proposals would be strongly recommended, for any future work of similar nature, to ensure accurate assessment of solid performance:

1. Solid performance should be measured in terms of 'point velocity', at a given location, and not in terms of 'average velocity', over an extended length. In practice, this means that velocity should be measured over as short a distance as possible. This would serve to clarify modulative deceleration patterns.
2. A number of moveable velocity measurement points should be employed. These should be interspersed, between the fixed measurement points, over that length of pipework which, for any specific test, corresponds to the initial half of 'zone 2' dominated flow. This would serve to further clarify performance over those areas subject to pronounced modulative flow.

3. Accepting that the length of straight pipe which can be achieved in any experimental environment must be subject to definite limits, the very maximum length practicable should be constructed. Thus, the number of different gradient tests which may be conducted, without crucial loss of 'zone 2' data, is itself increased to a maximum.
4. At least three separate gradient tests should be performed, in any one series of tests, for a particular combination of either solid type, or flush type, and system geometry. The accuracy of estimation, for 'C1', may, in this way, be assured.
5. The gradient, for at least one of each series of tests, should be so reduced as to ensure that all solids are either deposited, or closely approaching the point of deposition, prior to system clearance. The accuracy of estimation, for 'C3', may in this way be assured.

10.3.2.2 W.C. Design.

The best approach, to preserve continuity, would have been to employ W.C.s of the same type and manufacture throughout all investigations. However, force of circumstance and the need to comply with other basic requirements rendered this impractical. As previously stated, in Section 4.1, two different types of P-trap W.C. pan were employed during laboratory experiments. The situation was further complicated by the fact that, on-site, and as detailed in Section 9.3.2, the installed W.C.s were of an S-trap variety.

During initial laboratory investigations, designed to assess the suitability, as substitutes for faecal matter, of various different materials, an Armitage Shanks V1206, P-trap, back inlet, (B.S.3402) W.C. pan was employed. Enquiries had suggested the aforementioned pan, being Ministry of Health approved, to be widely installed in the hospital environments with which this study was primarily concerned. Due to the lack of published information concerning the physical properties of faecal material, these investigations had eventually to be abandoned. It was concluded that a best approach, to ensure the

practical value of future laboratory investigations, was simply to assess the performance of various sterile model solids in comparison to actual 'live-waste' results.

By this time, an extensive range of sanitary towels, baby diapers and tampon products, had been tested on a consultancy basis for the U.K. Association of Sanitary Protection Manufacturers, (A.S.P.M.), who had required to ascertain the 'flushability' of their products. The results of these tests were made available by A.S.P.M., and were considered invaluable, in that they provided a 'bank' of various transport characteristics, from study of which, those products could be selected which best assimilated to 'live waste' results. However, the A.S.P.M. work had been concerned with the broader sphere of domestic and commercial environments, and as such had utilised an appropriate W.C. pan. A survey conducted by the Council of British Ceramic Sanitaryware Manufacturers, (C.B.C.S.M.), concerning the market penetration of various W.C. types in the U.K., had suggested the Twyford's P-trap, back-inlet, (B.S.1213), W.C. pan to be widely installed. This type of pan had therefore been employed for the A.S.P.M. flushability tests.

The 'site' location, later selected as the most suitable of those available, did not satisfactorily meet with all of the required conditions. One of the factors considered unfortunate was that the installed W.C.s were Armitage Shanks V1207 S-trap (B.S.3402) pans. These were similar to the V1206 W.C. pans, as employed during the initial laboratory investigations, except that each included a top flush pipe inlet, as opposed to a back inlet, and an S-trap outlet, as opposed to a P-trap outlet. A pre-condition of the 'on-site' monitoring programme was that interference to normal hospital routine would be kept to an absolute minimum. Replacement of the installed W.C.s was therefore not considered an acceptable course of action.

The different transport characteristics displayed by sanitary towels, resulting from the use of various different W.C.s as the input device, were investigated by Wakelin (1978). It was found that S-trap W.C.s gave consistently higher solid discharge velocities than comparable P-trap W.C.s, but it was also suggested that, although S-trap W.C.s discharged solids later in the flush, P-trap W.C.s allowed greater

leakage past solids in transit. Wakelin (1978) suggested that the inter-relationship, between discharge velocity, depth of flow and percentage of flush ahead of solid at discharge, was not definable. However, from analysis of the variation of 'C3', it was concluded that S-trap W.C.s afforded more efficient solid transport than P-trap W.C.s, as did Armitage Shanks W.C. pans in comparison to Twyfords W.C. pans.

The solid velocity profiles, presented in Figures 10/80 to 10/87 inclusive, were recorded by Wakelin (1978) in his study of comparative W.C. performance. As outlined in Section 10.3.2.1, specifically in reference to Figures 10/78, 10/79, 10/80 and 10/84, each of these Figures relates to its own particular test series. Within each series, the only variable was the gradient at which results were achieved, but for each particular series a different combination of W.C. type and model solid was employed. As explained in Sections 10.3.1.2 and 10.3.2.1, the method of 'least squares', as employed by Wakelin to calculate linear estimates of 'zone 2' deceleration, was not considered appropriate for such a purpose. Thus, for each series of tests, a re-assessment of linear deceleration has been performed.

Wakelin examined the performance of four different types of W.C. pan, each in turn, with three different types of sterile 'waste-load'. The four types of W.C. pan were:

1. Armitage Shanks, V1206 P-trap (Back inlet) B.S.3402.
2. Armitage Shanks, V1206 S-trap (Back inlet) B.S.3402.
3. Twyfords, 11006 P-trap (Back inlet).
4. Twyfords, 11006 S-trap (Back inlet).

The three different types of sterile 'waste-load' were:

1. Single Maternity Pad.

2. Maternity Pad and three Kleenex paper towels.

3. Maternity Pad and three Bowater paper towels.

The results achieved from the use of the Maternity pad and Bowater towel combination have not been presented here, as they mirror the results of the Maternity pad and Kleenex towel combination extremely closely.

Figure 10/80 shows that sufficient data was collected, for the case of a single Maternity pad discharged via an Armitage Shanks P-trap W.C. pan, to allow a reasonably accurate estimate of linear deceleration characteristic. The same is true of Figure 10/84, for the case of a Maternity pad and three Kleenex towels discharged via the same type of W.C. pan. However, during examination of the three other types of W.C. pan employed, much less data was collected (see Figures 10/81, 10/82 and 10/83, for the case of a single Maternity pad, and Figures 10/85, 10/86 and 10/87, for the case of a Maternity pad and three paper towels). Only two different gradients were examined per test series, and due to particular combinations of gradient and solid type, far too few velocity measurement points were suitably placed to coincide with 'zone 2' flow conditions. In addition, several of the averaged velocity profiles presented were compiled from as few as ten individual flushes. In view of the facts presented in Section 10.3.2.1, concerning the experimental approach required to assure accurate assessment of 'zone 2' linear deceleration, it can only be concluded that, for the work under discussion, the approach was somewhat less than adequate.

Wakelin (1978) had suggested each of the inter-dependent constants, 'C1' (the theoretical velocity, on the 'zone 2' linear characteristic, coincidental with $\sqrt{L/G}$ equal to zero), 'C2' (the negative gradient of the 'zone 2' linear characteristic), and 'C3' (the theoretical value of $\sqrt{L/G}$, on the 'zone 2' linear characteristic, coincidental with velocity equal to zero). to be a function of the input device. However, during initial observations, aimed at the reassessment of each linear deceleration characteristic, as previously mentioned, it seemed by no means obvious that any change in the value of 'C2' had occurred, for either particular

flush load, with change of input device. As only those tests conducted with the Armitage Shanks P-trap W.C. pan, in conjunction with each of the two different flush loads, were considered sufficiently comprehensive to allow accurate assessment of linear deceleration, the following approach was taken to determine this point; the constant 'C2' was assumed not to be a function of the input device; the value of 'C2', for each particular type of flush load, was assumed to be that suggested by those tests which employed the Armitage Shanks P-trap W.C. pan; in attempting to fit linear characteristics to the remaining data, obtained from use of the other three types of W.C. pan, precognition of 'C2' was assumed.

From graphical presentation of the resultant linear characteristics, each superimposed upon the relevant velocity profiles, it can be seen that; for those examples where the velocity profiles achieved at different gradients strongly reinforce one another, no significantly different value of 'C2' could possibly fit the data; for those examples where some discrepancy is displayed between velocity profiles achieved at different gradients, although other values of 'C2' might equally well fit the data, none could better fit the data. See Figures 10/81, 10/82 and 10/83, for the case of a single maternity pad, and Figures 10/85, 10/86 and 10/87, for the case of a maternity pad in combination with three Kleenex paper towels.

Thus, no evidence is apparent, from Wakelin's (1978) data, to refute the assumption that, for any particular type of flush load, the value of 'C2' is independent of input device. That Wakelin (1978) concluded otherwise, can only be attributed to a misinterpretation of the data. However, as much of Wakelin's (1978) data was considered less than adequate to enable accurate assessment of linear deceleration, it could be suggested that a more comprehensive investigation, in-line with the recommendations outlined in Section 10.3.2.1, might have detected some inter-dependence between 'C2' and the input device. It so happens that Marriott (1979) performed just such other relatively comprehensive investigations, into the performance of two other types of W.C. pan, using single maternity pads as the flush load, and under identical conditions to those employed by Wakelin (1978), see Figures 10/78 and 10/79. It can be seen that the estimate of 'C2', arrived at

from Wakelin's (1978) maternity pad data, provides as good a 'fit' to this data as it is realistically possible to achieve.

In his study of the effects upon waste solid transport of reduced flush volumes, Marriott (1979) proved beyond question that, for any particular solid type, 'C2' is a function of flush volume (with reduction in flush volume, the scalar value of 'C2' increased). That different types of W.C. pan, when primed with identical loads and set to discharge identical amounts of flush water, result in different proportions of that flush water being discharged ahead of the solid load, must suggest the amount of water, effective to solid transport, to vary from one type of W.C. pan to the next. Thus, from a theoretical standpoint, it is suggested that 'C2' must be a function of the input device.

It can only be concluded, that variations in the value of 'C2', resulting from the use of different W.C.s as the input device, are small in comparison to the level of accuracy with which the value of 'C2' can be determined, at least as regards the types of W.C. pan so far investigated.

That, for a particular waste load, 'C2' may be considered, for all intents and purposes, as independent of the input device, allows that the effects upon waste solid transport, resulting from the use of different W.C.s as the input device, may be defined simply in terms of either 'C1', or 'C3', (as $C1/C3 = C2$). With regard to the four different W.C. pans employed by Wakelin (1978), the changes in 'C1', (or 'C3'), can be tabulated for the two different waste load examples:

	Proportional change in 'Cl' (as compared to 'Cl' achieved with Armitage Shanks V1206 P-trap).		Absolute change in 'Cl' (m/s), (as compared to 'Cl' achieved with Armitage Shanks V1206 P-trap).	
	Single Maternity Pad.	Mat. Pad + 3 Kleenex towels.	Single Maternity Pad.	Mat. Pad + 3 Kleenex towels.
Armitage Shanks V1206 P-trap.	1.000	1.000	0.000	0.000
Armitage Shanks V1206 S-trap.	1.052	1.046	+0.081	+0.090
Twyfords 11006 P-trap.	0.919	0.846	-0.128	-0.300
Twyfords 11006 S-trap.	1.033	1.015	+0.052	+0.030

Similarities can be seen between the variations which occurred with the different types of waste load, but even though the 'proportional' comparison displays somewhat better agreement, it remains by no means obvious as to whether assessment in either proportional terms, or absolute terms, is most appropriate. As previously mentioned, much of Wakelin's (1978) data was not considered sufficiently comprehensive, and that this was the case could have served to veil any clear similarities which might otherwise have been apparent. However, even had such a straightforward relationship been apparent in this case, it could not have been concluded that all other types of wasteload would be similarly affected. In fact, it would only be

expected that variations in solid transport, resulting from the use of different types of W.C. pan, would reflect, to some degree, the particular type of waste solid employed.

The only route, to a full appreciation of comparative W.C. performance, must involve comprehensive examination of selected W.C. pans, each in combination with a wide range of different waste loads.

As discussed in Section 10.3.1.2, the method of 'least squares' as employed by Wakelin (1978) to calculate linear estimates of 'zone 2' deceleration, was not appropriate for such a purpose. In consequence, only random variations were displayed, with change of W.C. pan, by Wakelin's (1978) estimates of 'C1' and 'C2'. In face of this, Wakelin (1978) drew conclusions as to the comparative performance of the W.C. pans examined on the basis of variations in 'C3'. These conclusions were qualitatively correct, due to the fact that, as discussed in Section 10.3.2.1, 'C3' may quite accurately be estimated from rather less than fully comprehensive data. The considerable differences between those estimates of linear deceleration achieved by the method of 'least squares', as compared to those achieved in the manner prescribed in the study, can be seen from the values of 'C1', 'C2' and 'C3', presented in Figure 10/88, which relate to the various W.C. performance tests.

In reference to Wakelin's (1978) conclusions, regarding the slightly improved waste solid performance achieved by use of an S-trap W.C. pan, as compared to a comparable P-trap W.C. pan, there is a final point worthy of mention. All solid velocity measurements have been quoted in relation to distance from the W.C. pan. The zero datum, for all such distance measurement, was the centreline of the vertical inlet to the discharge pipework. However, according to its particular make and type, the relative position of the W.C. pan varied, see Figures 4/6 and 9/6. This was also the case for the experiments conducted by Wakelin (1978). The P-trap W.C. pans were some 340 m.m. further removed from the vertical inlet pipe than either of the S-trap W.C. pans, and the piperoute, prior to the vertical inlet pipe, was slightly less direct in the case of the P-trap W.C. pans. At least a part of the observed improvement, displayed by S-trap W.C. pans, can therefore be attributed to these factors.

Uujamhan (1981) conducted an extremely comprehensive investigation, into Water Conservation W.C. Design, which involved study of the design parameters affecting W.C. performance. However, this work relates primarily to the comparative assessment of W.C. pan efficiency, and although one method of assessment involved the discharge, and subsequent velocity monitoring, of various sanitary protection products, this section of the work employed, rather than extended, the current understanding of this topic.

10.3.2.3 W.C. Discharge Geometry.

Two variables, concerning discharge geometry, proved uncontrollable in the site environment. These were, the orientation of W.C. pan, in relation to horizontal discharge pipe, and the distance of the vertical drop, between W.C. pan and horizontal discharge pipe.

10.3.2.3.1 W.C. Orientation.

In all of the laboratory investigations, tests were conducted with the W.C. pan aligned to the discharge pipe, the back of the W.C. pan facing the direction of flow, see Figure 4/6. However, the only possibility for W.C.3., at the female 'on-site' facility, was to run the discharge pipe in exactly the opposite direction, see Figures 9/6 and 9/15, the W.C. pan aligned to the discharge pipe, but with the front of the W.C. pan facing the direction of flow. As is also illustrated in Figure 9/15, the orientation of W.C.2. at the female 'on-site' facility, in relation to the initial length of its associated discharge pipe, was approximately 45° offset from the aligned position employed at W.C.3. The orientation of each W.C. at the male 'on-site' facility, in relation to its associated discharge pipe, compared roughly to that of its counterpart at the female facility. The exact details are presented in Figure 9/14. That the male facility did not compare exactly to the female facility, in this respect, was a result of there being insufficient clear space in the area of interfloor service void beneath the male facility, as outlined in Section 9.4.3.

Consider a solid, discharged from a P-trap W.C. pan, entering that vertical pipe section prior to the horizontal discharge pipe. Uujamhan (1978) reported that such solids were observed to fall vertically

downward, either centrally, or in that half sector of the pipe cross-section opposite to the W.C. Pan. Although no quantitative evidence was presented to support the observation, it seems only logical that this should indeed be the case. With the W.C. pan aligned to the discharge pipe, its back-end facing the direction of flow, the solid will therefore be more likely to hit the $92\frac{1}{2}^{\circ}$ elbow at the bottom of the vertical pipe section, somewhere between points 'Y' and 'Z' as detailed in Figure 10/89A, rather than between points 'X' and 'Y'. Again with the W.C. pan aligned to the discharge pipe, but with its front-end facing the direction of flow, as detailed in Figure 10/89B, the solid will be more likely to hit the $92\frac{1}{2}^{\circ}$ elbow between points 'X' and 'Y' rather than between points 'Y' and 'Z'.

The nearer to point 'Z' that impact occurs, the greater will be the resultant losses, and the smaller will be the component of solid velocity directed horizontally. Thus, for the particular combination of fittings employed, the arrangements detailed in Figures 10/89B and 10/89A should, in theory, represent the best and worst possible, respectively, as regards W.C. orientation. It would also be expected that, for W.C. orientations other than the two extremes mentioned, relative performance would vary in proportion to some function of the angular displacement from each. Although no comprehensive study specifically concerned with this aspect of performance has, to date, been published, two W.C. discharge arrangements, of those considered by Uujamhan (1978), are of some interest. For the first of these, the discharge arrangement was identical to that of Figure 10/89A, for the second, the W.C. pan was rotated through 90° , (the W.C. outlet being at right-angles to the discharge pipe). In-line with the previously outlined theory, and as regards resultant waste solid transport, the latter arrangement proved the better of the two. However, the solid velocity data recorded by Uujamhan, relating to these discharge arrangements, was by no means sufficient to allow accurate numerical assessment of 'zone 2' deceleration. The improvement observed must, therefore, remain a qualitative assessment.

The effects of W.C. orientation, up to this point, have been viewed in relation to the use of P-trap W.C. pans. It is considered that, although in proportional terms the effects may be less pronounced, the conclusions drawn would apply equally well to the use of S-trap W.C. pans. Assuming this to be the case, it can be seen, from Figures 9/14 and 9/15, that W.C.3. had an advantage, as regards W.C. orientation, over W.C.2., as did W.C.5. over W.C.6.. However, it also follows that W.C.3. had a slight advantage over its counterpart at the male facility (W.C.5.), as did W.C.2. over its counterpart at the male facility (W.C.6.).

10.3.2.3.2 Vertical 'Pipe-drop', (And Re-evaluation Of The 'Zone 1' Condition).

Vertical 'pipe-drop', for the purposes of this work, was defined as the distance between base level of W.C. pan and centreline of horizontal discharge pipe. This dimension was set to 300 mm., during all laboratory investigations, as this had been the approach adopted by most previous researchers. However, during construction of the new U.P.V.C. service pipework, to the female 'on-site' facility, it was found that a 'pipe-drop' of 300 mm. could not be achieved.

As outlined in Section 8.1, the C.I. pipework, serving each W.C. to be monitored, was cut off at a point slightly beneath the ceiling level of the floor void. The protruding C.I. stub, beneath each W.C., was then connected to a short vertical length of transparent U.P.V.C. pipe, which was itself connected to the horizontal discharge pipe by a 92½° bend. In other words, it was first necessary to connect from C.I. to U.P.V.C. pipework, and then to turn to the horizontal plane. A certain minimum vertical height was required to achieve this, while employing good jointing techniques, and given that the floor slab was approximately 203 mm. thick, (including screed), there was absolutely no possibility of achieving a 300 mm. 'pipe-drop'.

The 'pipe-drop' achieved, for the 'in-line' W.C. at the female facility (W.C.3.), was estimated to be 423 mm. This, and all other such dimensions, could only be estimated, as it was not possible to measure floor slab

thickness at any particular point, but only to assume compliance with design specifications. The estimated 'pipe-drop' at W.C.2., at the female facility, was 405 mm. That 'pipe-drop' was not identical for each female W.C., was the result of difficulties experienced in attempting to achieve clean and square cut edges, to the remaining C. I. stub pipes, so closely beneath the service void ceiling level. The situation was further complicated, on later installation of the male U.P.V.C. pipework, as it was found that the horizontal discharge pipe had to pass beneath certain other immovable building service pipes, if other requirements of the installation were to be successfully achieved, thus setting a maximum height to which the discharge pipe could be raised. In consequence, the estimated values of 'pipe-drop' for W.C.5. and W.C.6. were 471 mm. and 458 mm. respectively.

Simply from consideration of the greater energy transfer, from 'potential' to 'kinetic', resultant with increase in 'pipe-drop', it would only be expected that the component of solid velocity directed horizontally, after impact with the fitting at the bottom of the vertical 'pipe-drop', would vary in proportion to some function of 'pipe-drop'. Uujamhan (1978), in his investigation of W.C. discharge geometry, found an inverse proportionality of water ahead of solid with 'pipe-drop'. Solids were observed to 'overtake' leading flush water, not only in the vertical 'pipe-drop', but also in the initial length of horizontal discharge pipe. Obviously, any such increase in the amount of water behind a solid, resultant with increase in 'pipe-drop', must improve subsequent waste solid transport. It was also found that solid deformation, from the typical flat shape associated with high 'pipe-drops', became more frequent with reduction of 'pipe-drop'. Such 'deformation', it was suggested, reduced the efficiency of solid transport. The solids employed were various sterile sanitary protection products. Thus, it would seem inevitable that waste solid transport must improve as 'pipe-drop' is increased. However, there are certain other considerations involved. There is the possibility that, with increasing 'pipe-drop', a point may be reached beyond which any gain, to subsequent waste solid transport, would be counter-balanced by adverse effects of adhesion,

between waste solid and pipe-fitting, and of compaction, to the solid, on impact at the bottom of the 'pipe-drop'. Also, there is a theoretical 'pipe-drop' above which a solid will overtake all of the initial water discharge, and hence gain the maximum possible impulsion from the available flush volume, but the resulting loss of friction reduction effect (pipe lubrication), would then adversely effect waste solid transport.

Although Uujamhan (1978) conducted a fairly detailed study (of the effects upon waste solid transport of variation in 'pipe-drop'), for a number of reasons, this contributes little to useful quantitative understanding. The most serious 'drawback' was that, rather than focussing attention to the 'zone 2' flow condition, Uujamhan confined all detailed investigation to areas of 'zone 1' dominated pipework. Wakelin (1978) had described 'zone 1' as that initial condition, where:

"Velocity (of solid) was predominantly determined by centrifugal and impact forces, rather than by fluid frictional forces." *

The manifestation of this condition was described as follows:

"over the first 2-3 metres of pipe - velocity (of solid) was reduced considerably (from an initial high input value). Due to this initial deceleration, - water tended to dam up behind the - solid. This build up of water - provided an impulse to the solid, accelerating it - so that, by the 3-5 m. mark, a velocity of approximately 1m/s had been regained, (beyond which maximum, 'zone 2' flow conditions were considered to prevail)." *

It must be remembered, at this point, that the values quoted by Wakelin (1978) would vary according to solid type and system geometry. Uujamhan (1978) later concluded that 'zone 1' was not, in fact, a single zone, but was rather the aggregate of two distinct sub-zones; a 'deceleration' sub-zone, followed by a 'velocity regain' sub-zone. However, in light of observations regarding the 'zone 2' flow condition, as outlined in Section 10.3.1.2, re-evaluation of Uujamhan's (1978) 'zone 1'

* Author's inserts in parentheses.

data raises serious question as to whether or not 'zone 1' exists at all, as a separate and distinct flow condition.

One of the few tests conducted by Uujamhan (1978), in which some velocity measurements were recorded beyond that area considered to be 'zone 1', by chance employed exactly the same type of solid, and mirrored exactly the W.C. and system geometry, of a comprehensive 'zone 2' orientated study conducted by Marriott (1979). This data, recorded by Marriott, is presented in Figure 10/79, as is the associated equation for 'zone 2' deceleration, resultant from re-evaluation in-line with the new approach to estimation of 'linear deceleration', (as outlined in Sections 10.3.1.2 and 10.3.2.1). Thus, despite the fact that Uujamhan's data was by no means sufficient to allow accurate assessment of 'zone 2' deceleration, the appropriate assessment was achieved from Marriott's data, and the resultant characteristic has been superimposed, in Figure 10/90, upon Uujamhan's 'zone 1' data. It can be seen, that the manner in which individual solid velocity profiles are dispersed, about the linear characteristic, is exactly as would have been expected, had it been assumed that 'zone 1' was not a separate and distinct regime, but was simply the initial section of that regime so far referred to as 'zone 2'. The modulations displayed are of greater amplitude initially, than would have been expected at points more distant from the input device, but as previously mentioned in Section 10.3.1.2, specifically in reference to that area formerly considered as 'zone 2', such oscillations decay with distance from the W.C..

That 'zone 1' was ever considered a distinct and separate flow condition, can be similarly attributed to that misconception, through which earlier researchers failed to appreciate both, the 'modulative' nature of 'zone 2' deceleration, (Section 10.3.1.2), and the fact that the 'zone 3' flow condition is not an inevitable progression, (Section 10.3.1.4). The misconception was, that solid performance could be classified solely from consideration of 'average' velocity profiles. In fact, it is only from consideration of individual component solid velocity profiles that a true appreciation of performance can be achieved.

The assumption, that either random impact of the solid on the pipe walls, and/or the action of centrifugal forces (resultant on solid passage through the 92½° elbow, at the bottom of the vertical 'pipe-drop'), are responsible for the establishment of a distinct and separate initial flow condition, now seems improbable. A more logical explanation is as follows:

Due jointly to the mode of W.C. discharge, and to the combined effects of the vertical 'pipe-drop', a waste solid enters the discharge pipe with considerable momentum. From this point on, the 'stored' energy of the solid is gradually dispelled, as is that of the surrounding water, and the respective velocities are reduced in consequence. As 'static' forces delay this loss of energy, the solid decelerates in proportion to $\sqrt{L/G}$. The point at which all 'stored' energy has been dispelled, and at which solid transportation becomes totally dependent upon 'static' forces, marks the end of that flow condition formerly described as 'zone 2'. However, due again to both the mode of W.C. discharge and the combined effects of the vertical 'pipe-drop', a substantial disparity is normally set up, in the initial length of horizontal discharge pipe, between the velocities of waste solid and surrounding water. Thus, from the outset of horizontal transportation, a 'push me-pull you' effect is set up, between the solid and its surrounding water. Throughout the course of solid deceleration, consecutive momentum transfers occur, both to and from the surrounding water, which, of necessity, result in waste solid velocity fluctuations. These fluctuations are initially of considerable amplitude, as initial momentum transfers are extremely 'violent', but they remain simple modulations about the 'linear' deceleration characteristic. When comparing velocity profiles achieved for different, but basically identical, solids, initial modulations are more closely 'in-phase' with one another, than are subsequent modulations. Therefore, in calculating 'average' velocity profiles, initial oscillations tend to reinforce, rather than cancel, one another. In this way, the misconception was born, that 'zones 1 and 2', as formerly referred to, were distinct and separate flow conditions.

To avoid confusion, over the remainder of this work, the three 'zone' terminology will be continued, although it must be borne in mind that there is no real distinction between 'zone 1' and 'zone 2'.

Returning to consider Uujamhan's (1978) study (of the effects upon waste solid transport of variation in 'pipe-drop'), and bearing in mind both the above refutation of the 'zone 1' flow condition, and the prerequisites to accurate assessment of 'zone 2' deceleration (as listed in Section 10.3.2.1), it can be seen that determination of solid performance, from 'zone 1' data alone, is virtually impossible. Uujamhan (1978), in formulating an equation to predict initial solid deceleration, (which he suggested to be the first of two sub-sections to 'zone 1'), was simply providing a measure of the initial amplitude, frequency and wavelength, of the initial oscillation about the basic 'zone 2' deceleration characteristic, which characteristic could not be accurately determined on the data available.

That Uujamhan (1978) failed to investigate sufficient lengths of 'zone 2' dominated pipework, and that he also performed all tests at a single gradient, of 1:80, must render invalid any attempt to evaluate 'pipe-drop' numerically, in relation to 'zone 2' deceleration, by re-assessment of the basic data collected.

It must not be forgotten that, by the definition of 'pipe-drop' previously outlined, (the vertical distance between base of W.C. pan and centreline of horizontal discharge pipe), no account is taken as to whether a W.C. pan is of P-trap or S-trap design. Uujamhan (1978) employed a horizontal outlet P-trap W.C. pan, and was therefore able to define 'pipe-drop' as; the vertical distance between centreline of W.C. outlet and centreline of horizontal discharge pipe. However, such definition could not be transposed to other types of W.C. pan, and despite the fact that, in respect of 'pipe-drop', W.C. pans of different design are not truly comparable, a universal definition is required. Nonetheless, in view of both the previous discussion of 'pipe-drop', and Wakelin's (1978) study of W.C. design, (as outlined in Section 10.3.2.2, and in which 'pipe-drop', as defined in this work, was held constant), it can safely be concluded that the 'on-site' arrangements

held an advantage, as regards 'pipe-drop', over the laboratory arrangement. It can also be concluded that, in the same respect, W.C.5 held an advantage over W.C.6, as did W.C.6 over W.C.3, as did W.C.3 over W.C.2.

10.3.2.4 Cistern/Flush Pipe Geometry.

Connection, between flush pipe and W.C. pan, for both types of P-trap W.C. pan employed in the laboratory, was via a 'back-inlet' to the W.C. pan. For each, of the Armitage Shanks V1207 S-trap W.C. pans employed 'on-site', connection was via a 'top-inlet' to the W.C. pan. Thus, the geometry of flush pipe, between each cistern and its respective W.C. pan, could not be maintained throughout, see Figures 4/6 and 9/6. Both the Armitage Shanks V1206 P-trap 'back-inlet' W.C. pan, as used for the initial laboratory tests, and the Armitage Shanks V1207 S-trap 'top-inlet' W.C. pan, as installed 'on-site', being Ministry of Health Selected Designs, were covered by Ministry of Health Assembly Codes. In accordance with these codes, which give recommendations as to relative position of cistern to W.C. pan, the vertical distance between base of cistern and base of W.C. pan, for that cistern feeding the P-trap 'back-inlet' V1206 W.C. pan, was set to 745 mm.. The assembly codes do not recommend an exact distance for the horizontal position of cistern in relation to this particular type of W.C. pan. However, a 'back-inlet' W.C. pan would normally only be used when the cistern was to be separated from the W.C. pan by a partition. The horizontal distance, from the centreline of the vertical section of flush pipe to the back face of the W.C. pan, was therefore arbitrarily set, to simulate a fairly thick partition, at 320 mm.

Although a best approach, to preserve continuity, would have involved replacement of the V1207 'top-inlet' S-trap W.C. pans installed 'on-site', with V1206 'back-inlet' P-trap W.C. pans, as a precondition of the 'on-site' investigations, laid down by Hospital Management, was that interference to normal hospital routine would be kept to an absolute minimum, this was not an acceptable course of action. For the same reason, it was not even possible to re-adjust the positions of the associated cisterns. The relative position of cistern to W.C. pan,

as installed 'on-site', is illustrated in Figure 9/6. It is worthy of mention that, although the Ministry of Health Assembly Codes recommend the vertical distance, between base of W.C. pan and base of cistern, to be 1060 mm. for this particular arrangement, the dimension was found to be 1145 mm. for the installed equipment.

The flush pipes used in conjunction with Armitage Shanks W.C. pans, both in the laboratory and 'on-site', were of 38 mm. (1½") internal diameter, as recommended by the assembly codes.

The cistern to W.C. arrangement employed in the laboratory, for the Twyford's B.S. 1213 P-trap 'back-inlet' W.C. pan, was identical to that used for the Armitage Shanks V1-206 P-trap 'back-inlet' W.C. pan. This Twyford's W.C. pan was not a Ministry of Health Selected Design, and was therefore not specifically covered by the assembly codes.

In his investigation of W.C. discharge characteristics, Wakelin (1978) examined the changes in solid discharge velocity, and in percentage flush ahead of solid, % F.A.S. (measured at W.C. discharge), resultant with adjustment of cistern mounting, (from low to high level, as defined by Ministry of Health Assembly Codes). For the case of high level cistern mounting, tests were performed both with and without flush pipe restrictors. The % F.A.S. was found to be unaffected by cistern height adjustment, unless flush pipe restrictors were employed, in which case the % F.A.S. increased. Solid discharge velocity, which increased with increase in height of cistern mounting, was found to be variously effected by the introduction of flush pipe restrictors, the particular size and type of restrictor seeming to be the 'key' factor.

However, the two parameters monitored by Wakelin (1978), namely solid velocity and % F.A.S. at W.C. discharge, are not, alone, sufficient to define an hydraulic advantage, or disadvantage, to a solid in transit. Such factors as the absolute discharge velocity of the surrounding flush water, and the volume flow rate of that water, are also vital indicators of likely solid performance. The suggestion that a considerable disparity is normally set up, at the outset of 'horizontal' flow, between the velocities of solid and surrounding flush water,

was advanced and discussed in Section 10.3.2.3.2. None the less , even had sufficient discharge characteristics been monitored, without specific investigations, to relate the various parameters involved to subsequent solid performance, it would have been extremely difficult to predict the significance of any observed variations. Thus, the possibility remains that increased height of cistern mounting may improve subsequent solid transportation, but far more extensive investigations would be required to determine this point. In any event, within the limits of adjustment possible, such variations could only be very limited.

A preliminary investigation was conducted of the effects, upon 'sterile' solid transport, of varying both the internal diameter of flush pipe and the horizontal length of flush pipe (measured as the horizontal distance between centreline of vertical section of flush pipe and back face of W.C. pan), for which the input device was an Armitage Shanks V1206 P-trap 'back-inlet' W.C. pan. This work was presented in an appendix to a report, issued in November 1978, compiled by the author in conjunction with Swaffield (1978). The aim of this work was to determine the relevance of flush pipe geometry, to the study of waste solid transport, and thereby, to gauge the importance, to other investigations, of continuity in this respect.

Three separate tests were conducted: the first as a 'control'; the second to incorporate a step reduction of 200 mm. (62.5%) in horizontal flush pipe length, otherwise being identical to the 'control'; the third to incorporate a step increase of approximately 3 mm. (9.1%) in bore (internal diameter) of flush pipe, otherwise being identical to the 'control'. The pipe gradient was held at 1:80 throughout and thirty separate runs were recorded for each test. The 'model' solids, employed throughout, were single maternity pads, each of which was introduced to the W.C. unfolded, and allowed to soak thoroughly prior to discharge, in order to obtain maximum repeatability. Statistical analyses were conducted, employing the methods of 'Snedecor's 'f' test' and 'Students 't' test', to evaluate the significance of resultant variations in solid velocity sample variance and solid velocity sample mean respectively, as

recorded at each of six equidistant velocity measurement points, which were dispersed over the 14 metres of horizontal discharge pipe. It was concluded that each, of the two adjustments to cistern/flush pipe geometry, had definitely altered solid transport, although the differences were considered, in each case, to be minimal. However, in light of the revised estimation, as to the mode of waste solid transport, resulting from study of 'on-site' data, it was necessary to re-examine this work.

The average velocity profiles achieved from the three cistern/flush-pipe geometry tests outlined, are presented in Figure 10/91. It can be seen that all three profiles are extremely similar, and it was for this reason that resort was made to statistical analyses, in order to determine whether real differences were being displayed, or whether the three profiles were simply different estimates of the same result. Figures 10/92, 10/93 and 10/94, each present an envelope of the individual solid velocity profiles, component to the 'control', 'horizontal length' and 'bore' tests respectively. The individual profiles presented were selected to illustrate the complete range of performance in each test. The same linear deceleration characteristic has been superimposed upon each of these figures, simply to provide a common base for comparison. It is not suggested that this characteristic is an accurate estimate of linear deceleration, for any one of the three average velocity profiles, as the data collected was far from sufficient to secure such an estimate (see Section 10.3.2.1). Due to the fact that solids were introduced to the W.C. pan in the unique manner previously outlined, resultant transport could not be compared to that, of the earlier study performed by Wakelin (1978), which would otherwise have provided a relevant deceleration characteristic (as detailed in Figure 10/88).

It can be seen that, apart from a single 'rogue' flush, which occurred during the test of increased flush pipe 'bore', each set of results appears to be similarly centred about the common linear deceleration characteristic. It is also apparent that the predominant modulative patterns, about the common characteristic, displayed by individual solid velocity profiles, are somewhat different for each test. Thus,

the statistical analyses previously performed, which seemed to suggest that there were real differences between the results of the different tests, had merely reflected differences in amplitude, wavelength, frequency and phase, at the particular points of velocity measurement, between the predominant modulative deceleration profiles associated with the different tests. As to whether or not any real differences exist between the results of the different tests, in respect of the linear deceleration characteristic about which modulations occur, such statistical analyses can not conclude.

Despite the fact that no obvious differences were discernable, relating to linear deceleration characteristic, much was apparent from study of both standard deviation of velocity, and percentage of flush ahead of solid, % F.A.S. (as measured at discharge from the monitored length of pipework).

The reduction in horizontal flush pipe length, of 62.5%, resulted in an increase of approximately 8.2% in the amount of water ahead of the average solid, (% F.A.S. increasing from 15.7% to 17.0%), while the standard deviation in the amount of water ahead of the average solid was reduced by approximately 18.1% (from 0.262 litres to 0.215 litres). The standard deviation in solid velocity, over the six different velocity measurement points, increased by an average of 11.7%. The increase in flush pipe bore, of 9.1%, resulted in an increase of approximately 23.3% in the amount of water ahead of the average solid (% F.A.S. increasing from 15.7% to 19.4%), while the standard deviation in the amount of water ahead of the average solid increased by 44.7% (from 0.262 litres to 0.379 litres). The standard deviation in solid velocity, over the six different velocity measurement points, increased significantly by an average of approximately 115%.

Thus, it appears that each, of the two adjustments to cistern/flush pipe geometry, gave rise to similar results; increased % F.A.S.; increased variability of solid transport (accentuation of modulative deceleration patterns). As discussed in Section 10.3.2.2, a reduction in the amount of useful water, namely that discharged behind the solid, must, on average, detract from subsequent solid transport. From the information

presented, it can be seen that the relevant reductions (in useful flush water), were approximately 1.5% and 4.4% for the 'horizontal length' and 'bore' tests respectively. Assuming that the resulting reductions in solid performance would have been of similar order, and bearing in mind, first of all, that the tests under discussion were somewhat less than sufficiently comprehensive to ensure accurate assessment of linear deceleration (see Section 10.3.2.1), and secondly, that each of the relevant linear characteristics was camouflaged by its own particular predominant modulative pattern, it could only have been expected that adjustments of this order, to average solid performance, would remain undetected.

That, in each case, the variability of solid performance was increased, reflects two separate occurrences. Firstly, an accentuation of modulative deceleration patterns, but also, a widening of absolute velocity variations, between individual deceleration profiles of otherwise similar modulative performance (re: amplitude, wavelength, frequency and phase, at any particular point). From comparison of the range of velocity profiles achieved in the 'control' test, to those achieved in the 'bore' test (Figures 10/92 and 10/94 respectively), both such occurrences are particularly noticeable. Assuming no absolute change in average linear deceleration characteristic, it might be argued that increased variability is of little consequence, but this is not considered to be the case. As outlined in Section 10.2.3, any acceptable method for above ground drainage design must be linked to the avoidance of solid deposition above an agreed safe limit, the exact level of which remains open to discussion. Such a design must, therefore, be based upon a linear deceleration characteristic, removed, from the relevant average linear deceleration characteristic, in proportion to some chosen multiple of standard deviation in velocity, thus representing that level of performance exceeded by the desired proportion of solids (which proportion would undoubtedly be the great majority). Thus, the variability of solid performance is an important consideration, and any adjustment to system geometry which could reduce variability, without reducing average solid performance, would be an advantage.

The effects, as outlined, upon solid transport, of the two adjustments to cistern/flush pipe geometry, although similar in principle were by no means similar in scale. The 9.1% (3 mm.) increase in flush pipe 'bore', as compared to the 62.5% (200 mm.) reduction in 'horizontal length' of flush pipe, caused almost three times the increase in % F.A.S., and almost ten times the increase in standard deviation of velocity, (averaged over the six different velocity measurement points). It can only be concluded that flush pipe 'bore' is by far the more sensitive of the two parameters.

It is possible to advance some explanation, from the information presented to this point, of the mechanisms by which the observed effects were initiated. It would be suggested that water turned from the vertical section of flush pipe, into the horizontal section, is initially very turbulent. By allowing a certain distance to be travelled horizontally, prior to the W.C. inlet, the flow becomes more uniform. Such a uniform delivery of water to the W.C. pan results in more efficient and more consistent W.C. pan performance. It follows, from this argument, that there is an optimum length of horizontal flush pipe, for any particular cistern/W.C. (back-inlet) design arrangement, at which flow is sufficiently uniform at W.C. inlet, and above which no extra advantage is to be gained. A similar argument would be advanced to explain the results of the 'bore' test. Increased internal diameter of flush pipe must result in two occurrences; increased volume flow rate; increased turbulence in the bowl of the W.C. pan. Assuming no loss of efficiency, increased rate of delivery to the W.C. pan, by increasing discharge momentum, can only serve to improve subsequent waste solid transport. However, increased turbulence in the pan can only result in W.C. performance becoming both less efficient and less consistent. It is therefore suggested, that for each particular combination of cistern, W.C. pan and flush pipe geometry, there is an optimum value of flush pipe 'bore'.

In conclusion, although the various tests conducted to date, involving adjustments to cistern/flush pipe geometry, have not been sufficient to allow the effects upon the efficiency of W.C. discharge to be quantified, (in relation to the resulting linear deceleration characteristics),

the recorded variations in % F.A.S. (measured at discharge from the 'horizontal' length of pipework), strongly suggest that such effects, although relatively minor, are none the less real. The attendant modifications to variability of solid performance, being much more significant, were obviously apparent. It is therefore suggested that, for any particular design and manufacture of W.C. pan and cistern, there are optimum arrangements of cistern/flush pipe geometry, to best promote waste solid transport, at which the correct balance is achieved, between the rate of delivery to the W.C. pan and the turbulence of that delivery.

10.3.2.5 W.C. Venting.

During all laboratory investigations, for which either an Armitage Shanks V1206 'back-inlet' P-trap W.C. pan (B.S. 3402), or a Twyford's 'back-inlet' P-trap W.C. pan (B.S. 1213), was employed, the relevant W.C. discharge was vented (as illustrated in Figure 4/6).

For each 'on-site' investigation, in which Armitage Shanks V1207 'top-inlet' S-trap W.C. pans (B.S. 3402) were employed, it had been intended that both 'vented' and 'un-vented' tests would be conducted. As no 'vent' system had previously existed at the relevant 'site' locations, tests were initiated without 'venting'. However, once the rate of data collection had been assessed, from study of 'site-operation' records collected over a period of several weeks, it became clear that insufficient time was available to allow repetition of work with 'vented' W.C. discharge.

Two separate investigations were conducted by Wakelin (1978), each of which was directed toward identification of W.C. discharge 'venting' effects. The first study was concerned with the examination of W.C. discharge characteristics, and the second was based upon examination of solid transport over a 14 metre length of discharge pipework. From the results of these investigations, Wakelin (1978) could only suggest that the observed variations were "not of sufficient significance" to allow definite conclusions to be drawn.

The solid velocity profiles, presented in Figures 10/95 to 10/102 inclusive, were recorded by Wakelin (1978). Each of these Figures relates to its own particular test series. Within each series, the only variable was the gradient at which results were achieved, but for each particular series, a different combination of W.C. type and model solid was employed. In each and every case, the W.C. discharge was vented. In fact, the eight Figures mentioned present data recorded under identical conditions to those results, presented in Figures 10/80 to 10/87, respectively, which were previously discussed in section 10.3.2.2, except that, in this former case, no W.C. discharge had been 'vented'. As explained in Sections 10.3.1.2 and 10.3.2.1, the method of 'least squares', as employed by Wakelin to calculate linear estimates of 'zone 2' deceleration, was not considered appropriate for such a purpose. Thus, for each series of 'vented' tests, as for each series of 'un-vented' tests, a reassessment of linear deceleration has been performed.

The 'vented' discharge tests were subject to the same shortcomings as were outlined, in Section 10.3.2.2, in respect of the 'un-vented' discharge tests. Thus, the linear deceleration characteristics, appropriate to the 'vented discharge' tests, were achieved by the same approach as that outlined in Section 10.3.2.2. Each, of the resulting linear characteristics, has been graphically superimposed upon the relevant average velocity profiles (Figures 10/95 to 10/102 inclusive).

The values of 'C1' (the theoretical velocity, on the 'zone 2' linear characteristic, coincidental with $\sqrt{L/G}$ equal to zero), 'C2' (the negative gradient of the 'zone 2' linear characteristic), and 'C3' (the theoretical value of $\sqrt{L/G}$, on the 'zone 2' linear characteristic, coincidental with velocity equal to zero), for both the 'vented' and 'un-vented' characteristics, are presented in Figure 10/88 for comparison.

As was the case with regard to the type of input device (Section 10.3.2.2), no evidence is apparent, from the available solid velocity data, to refute the assumption that, for any particular type of flush load, the value of 'C2' is independent of the 'vent' condition. It can only be concluded, that any variations in the value of 'C2' which may have occurred, with adjustment of the 'vent' condition, must be small in comparison to the

level of accuracy with which the value of 'C2' can be determined. That, for a particular waste load, 'C2' may be considered, to all intents and purposes, as independent of the 'vent' condition, allows the effects upon waste solid transport, resulting with adjustment of the 'vent' condition, to be defined simply in terms of either 'C1' or 'C3' (as $C1/C3=C2$).

Proportional variations in the re-assessed values of 'C3', resulting as a consequence of venting W.C. discharges, and as pertinent to the four different types of W.C. pan employed by Wakelin (1978), (each in combination with two different types of solid load), are presented in Figure 10/103. The simultaneous variations in both the amount of useful flush water (that remaining behind the solid at the point of outlet from the 'horizontal' discharge pipe), and the standard deviation of solid velocity (averaged over the six different velocity measurement points associated with each test), as calculated from Wakelin's (1978) original data, are also presented in Figure 10/103.

It is apparent, from Figure 10/103, that variations in both the amount of 'useful' flush water, and the standard deviation of solid velocity, follow no visible pattern. It can only be concluded, that the observed variations in these two parameters, some of which would individually seem quite significant, can not be attributed to the 'vent' condition of W.C. discharges. It may well be that these variations were purely random. In fact, from theoretical consideration of the possible effects of adjustment to W.C. discharge 'vent' condition, there is no reason to suggest that any variation in solid performance would be reflected by any simultaneous variation in either of the two parameters mentioned. Adjustment to the 'vent' condition might be expected to cause some change in either, or both, of the parameters; volume flow rate of flush water; absolute velocity of flush water. Such an eventuality would certainly cause a sympathetic response from any waste solid in transit, but may well not effect, to any noticeable degree, either the amount of water initially to the fore of any solid, or the rate at which water bypasses any particular solid.

Wakelin (1978) computed an average value for the variation in 'C3', resulting as a consequence of venting the W.C. discharge, based upon all of the 'paired' test results (vented and unvented), and irrespective of input device or solid type. As this 'mean' value was extremely small, Wakelin (1978) suggested that, "the result was not of sufficient significance" to allow definite conclusions to be drawn. A comparative overall 'mean', based upon the estimates of 'C3' presented in Figure 10/88, would suggest 'C3' to be reduced, by approximately 0.3%, as a consequence of 'venting' the W.C. discharge. This value might well be considered 'insignificant'. However, it can be seen, from Figure 10/103, that such an overall 'mean' only serves to distort the actual results, as the effect of 'discharge venting' was apparently dependent upon the particular type of input device employed.

A significant observation, concerning the variations in 'C3', is that, despite the fact that each type of W.C. pan displayed a different effect, the results obtained for any particular type of W.C. pan, with the 'maternity pad and three towel' solid load, in each case very closely resemble those obtained with the 'single maternity pad' solid load. That this was the case, and that each value of 'C3' was arrived at from at least two separate gradient tests, must suggest the variations to be real, and not merely random.

Variations in 'C3', resultant with 'venting' each of the 'S-trap' types of W.C. pan, were so small as to be less than the possible margin of error in estimation of 'C3'. 'Venting' the discharge of the Armitage Shanks P-trap W.C. pan caused values of 'C3' to be somewhat reduced, (by approximately 4%), whereas, with the Twyfords P-trap W.C. pan under the same circumstances, values of 'C3' were somewhat increased (by approximately 3%). That, as far as it was possible to determine, the S-trap types of W.C. pan remained unaffected by 'vent' condition, while this was not the case for the P-trap types of W.C. pan, can possibly be attributed to the fact that, as illustrated in Figure 10/104, the 'venting' techniques employed by Wakelin (1978), for the two different types of W.C. trap arrangement, were not identical.

As to why the two different types of P-trap W.C. pan, upon being 'vented', displayed opposite effect, this work can not conclude. However, it would be suggested that the answer lies with the internal design of each particular W.C. pan.

10.3.2.6 Calibration Tests.

Those details of system geometry which, through force of circumstance, could not be identically reproduced at each of the monitored installations (and which have, to this point, been referred to as 'discontinuities'), are outlined in Sections 10.3.2.1 to 10.3.2.5 inclusive. Particular details are outlined and discussed, and current knowledge, relating to the various parameters concerned, is summarised. Were the relationships between each of these parameters and solid transport sufficiently well understood, then numerical adjustments could be applied to the measured solid velocity results, enabling direct comparison between results collected at different installations. However, as this level of understanding has yet to be achieved, it was inevitable that the different solid velocity results, collected at the different 'on-site' facilities, would not be directly comparable, either with one another, or with 'sterile' solid velocity results collected at the laboratory installation.

The only alternative, to calibration through quantitative understanding of the effects of individual 'discontinuities', which could allow for direct comparison between results collected at the different installations, was to attempt an empirical calibration between complete installations. From that time, at the outset of 'on-site' investigations, when it became apparent that certain 'discontinuities' were unavoidable, it was accepted that such an empirical calibration was also unavoidable. Thus, it was intended, firstly, that any real differences between the various 'live' waste loads, as discharged via the different W.C. pans, might be identified, and secondly, that the body of 'live' waste performance results might be compared to that body of 'model' solid performance results recorded in the laboratory.

In order to achieve such a calibration, the average performance, of at least two different types of sterile 'model' solid, had to be determined

in relation to each of the various 'site' and 'laboratory' installations. In accordance with the understanding of solid transport prevailing at that time, it was considered that a single gradient test would be sufficient, for any particular arrangement of 'system geometry', to allow accurate estimation of the linear deceleration characteristic associated with any particular type of 'model' solid. Although, by this time, a complete range of sanitary protection products had been tested in the laboratory, each at gradient 1:80, a far greater body of work had been conducted, by various other researchers, with single 'maternity pad' model solids. For this reason, the maternity pad was chosen as the first of the 'models' required for calibration purposes, and tests were initiated 'on-site'.

These first calibration tests were performed at the male facility, which was temporarily closed to the public, while the monitored length of transparent U.P.V.C. pipework was set at gradient 1:150. 'Loaded' flushes were discharged alternately from W.C.s 5 and 6. Although the probability of maternity pad solid deposition, within the monitored length of U.P.V.C. pipework, was not expected to be significantly, if at all, greater than that of normal 'live' waste solids, it was accepted that the introduction of a considerable number of maternity pads to the system, over a relatively short period, could cause problems in the C.I. service pipework further downstream. This connecting 'horizontal' C.I. pipework, downstream of the male facility, also served facilities other than those with which this study was concerned. In accordance with the initial permission for 'on-site' investigations, granted by Hospital management, it was vital that any interference to normal Hospital routine be minimal. The avoidance of any disruption to the wider network of above ground drainage was therefore a paramount consideration. To this end, after each successive 'loaded' flush, two separate 'water only' flushes were discharged. However, this basic safety procedure, which had been thought more than sufficient to ensure the avoidance of any problem 'downstream', proved to be inadequate. After a mere handful of maternity pad flushes had been successfully monitored, a blockage developed at some unidentified point downstream of the transparent U.P.V.C. pipework.

That individual maternity pad solids cleared the length of U.P.V.C pipework without difficulty, despite the gradient of 1:150, and yet, even with assistance from extra 'water only' flushes, were not able to clear the remaining 'horizontal' C.I. system (see Figure 9/9), which would not have been installed at any gradient flatter than 1:80 (regarded as the reasonable practical minimum gradient for pipes, of 100 mm. and 150 mm. internal diameters, in horizontal installations, Wise (1979)), is yet another clear indication of the importance of both good design, and precise construction, to efficient drain performance. It is worthy of mention at this point, that, once the blockage had developed, each flush of either W.C.5 or W.C.6 caused both self-siphonage of that W.C. pan, and locally induced siphonage of its sister appliance. Such siphonage would not have occurred had ancillary venting not been completely absent. However, that no other case was observed of either self-siphonage or induced siphonage of W.C. pans, during the complete course of this study, suggests that Wise's (1979) assertion, relating to 'horizontal' above ground drainage systems, that "the seals of W.C.s, about 50 mm. deep, could not usually be significantly affected even with ancillary venting completely absent", is quite correct for all normal system operation.

At this point, calibration tests were temporarily suspended, firstly, in order that the C.I. pipework might be expeditiously reinstated, but also, to allow that a review of the approach to system calibration might be conducted. In view of the requirement for 'non-interference to normal Hospital routine', it was imperative that a second blockage not be allowed to develop. As the problem had occurred in the immobile C.I. section of pipework, there was absolutely no guarantee that an increase of gradient, on the U.P.V.C. length of pipework, would substantially assist in the avoidance of a further blockage. This was especially true as, due to environmental difficulties, there were definite limits to the range of possible gradient adjustment. Similarly, there was no guarantee that an increase in the number of 'water only' flushes, discharged into the drainage system between successive 'loaded' flushes, would, alone, constitute a more effective safety procedure, particularly in view of the fact that only a handful of maternity pads

had been passed into the system, prior to the blockage being formed, whereas a minimum of 80 such solids would have had to be introduced to complete the intended calibration procedure (20 via each W.C. pan). It was decided that, from this point onward, it would only be acceptable for the very smallest of the available sanitary protection products to be employed for calibration purposes.

That it was not possible to continue calibration procedures, with the maternity pad solid, was considered unfortunate, as far less information was available relating to any other particular solid type. Although tests on as many as four or five different types of 'model' solid may have been required to ensure successful 'system calibration', in-line with original intentions, it was decided that, pending assessment of the initial results, tests should be restricted to the use of two different types of 'model' solid. The two products selected, on the basis of results achieved from the A.S.P.M. laboratory tests (see Section 6), were the 'Johnson and Johnson Carefree Panty Shield' and the 'Southall's Fastidia Mini-pad'. When calibration tests were re-initiated 'on-site', these products were employed, and the rate of introduction of 'water only' flushes, for system clearance purposes, was maintained at its former level.

The results of these calibration procedures, conducted with the panty-shield and mini-pad types of 'model' solid, are presented, in Figures 10/105 and 10/106 respectively, in the form of average velocity profiles. The differences between these profiles, resulting as a consequence of the differences in system geometry, between installations, will subsequently be discussed. However, some explanation of the unforeseen nature of these results must first be presented.

Although, at the time that these results were achieved, some early 'live' waste results had also been reduced to graphical form, the phenomenon of 'modulative deceleration', as discussed in Section 10.3.1.2, had not, as yet, been appreciated. Thus, the average velocity profiles, relating to those 'model' solid tests conducted 'on-site', in no way conformed to expectation. Despite the fact that, in retrospect, the modulative nature of these profiles is clearly apparent, at that time,

the results simply appeared to reflect some inaccuracy, the main cause of contention being the initial modulation, on each average velocity profile achieved at the female facility, which was blatantly apparent. To that point in time, slightly non-linear profiles had been attributed to the inaccuracies of solid velocity measurement, but the large 'dip', in each average profile achieved at the female facility, could not be so attributed. That the phenomenon was initially viewed as 'non uniform' deceleration, over a limited section of pipework, and at the one facility only, suggested some particular detail of system geometry, or some inaccuracy of construction, to be the root cause.

However, neither theoretical consideration, within the limits of the then current understanding of the mode of waste solid transport, nor examination and observation of the actual installation, with regard to gradient, pipework and fittings, could identify any such detail or inaccuracy. None the less, before any advance could be made, in the direction of 'system calibration', it was essential that the cause of this apparent 'non-uniform' deceleration be identified. It was at this point that recourse was made, not only to those 'live' waste results which had so far been collected, but also to the works of Wakelin (1978), Marriott (1979) and Uujamhan (1978), in order that all available data might be examined in sufficient detail to identify any previous instance, of similar nature, which may have been overlooked. From this investigation, the theory of 'modulative deceleration', as discussed in Section 10.3.1.2, and as further developed in subsequent Sections, was to emerge.

Within the 'modulative deceleration' theory, of the mode of waste solid transport, it is possible to explain those details, of the 'model' solid calibration test results, which could not be explained within the context of previous theories relating to waste solid transport. The large 'dip', toward the fore of each average velocity profile achieved at the female installation, represents those initial modulations, on each of the component individual solid velocity profiles, which were 'in-phase' with one another, and which, therefore, in calculation of an average velocity profile, tended to reinforce, rather than cancel, one another. That this phenomenon was far less apparent from results acquired at the male facility, was simply due to the 92½° bend incorporated into this system.

The length of straight discharge pipework, prior to the bend, was insufficient to allow realistic appreciation of recorded velocity data. That modulative deceleration was also less apparent, from the 'average' velocity profiles of 'live' waste solids, can be attributed to the fact that such solids were far from being identical. Each 'live' waste solid, discharged as the sole content of a flush, decelerated in accordance with its own particular deceleration characteristic, and modulated about this to its own particular pattern, whereas identical 'model' solids, discharged individually, all decelerated in accordance with roughly the same deceleration characteristic, and each displayed a similar modulative pattern. Thus, in calculation of average velocity profiles, the modulations of individual 'live' solids, being further out of 'phase' with one another than those of 'model' solids, were much more effectively cancelled out.

Earlier researchers, who conducted 'model' solid tests in a laboratory environment, failed to appreciate the 'bias' created in calculation of 'average' velocity profiles. For this reason, they also failed to identify the phenomenon of 'modulative' deceleration. However, the phenomenon was identified, during this study, largely due to the fact that, during 'model' solid 'calibration' tests conducted 'on-site', the process was unusually apparent. It is suggested, that this situation arose in response to a number of independent factors. Firstly, as the 'model' solids employed were unusually small, they were more susceptible to momentum transfers from the surrounding water, and therefore displayed greater velocity variations (see Section 10.3.1.2). Secondly, due to the fact that vertical 'pipe drops' employed 'on-site', at inlet to the discharge pipework, were larger than those employed previously in laboratory studies, the initial disparity, between the velocities of solid and surrounding water, tended to be unusually large, and therefore encouraged modulative interaction (see Section 10.3.2.3). Thirdly, as only particularly flat gradients were employed 'on-site', solid velocities were proportionally less than would otherwise have been the case. Thus, random turbulence was reduced, leaving ordered velocity variations less obscured, and modulative wavelength was reduced (in relation to pipe length), so that a greater number of complete modulations occurred, within the length of monitored pipework, and these provided a more noticeable feature.

Having formulated the theory of 'modulative' deceleration, and, with this in mind, re-examined the validity of the experimental approach previously employed (to determine the deceleration characteristic of any particular type of waste solid), it was concluded that, to ensure accurate estimation of solid performance, a far more rigorous and extensive experimental programme was required. The additional requirements, essential to such a programme, are listed in Section 10.3.2.1. Thus, it became apparent that a further review of the approach to 'system' calibration was required.

It now appeared necessary, not only to 'test' at least four different types of solid, through each of the relevant appliances, but also to test each solid type at a very minimum of three different gradient settings. The implementation of such a programme, in the 'site' environment, posed a number of substantial difficulties.

The two main reasons, for the performance of any particular test over a range of different gradients, are to obtain average deceleration characteristics of different predominant modulative patterns, and to obtain solid velocity data appropriate to as wide a range of ' $\sqrt{L/G}$ ' values as possible. To meet the second of these requirements, it is essential that gradients employed be specifically selected, in each case, to suit the particular solid under investigation. Thus, a wide range of different gradients would have had to be employed in order to successfully investigate the performance of a sufficient range of different solid types. However, despite the fact that, in order to maximise the range of possible gradient adjustment, the pipework for each of the 'on-site' U.P.V.C. service systems had been carefully selected (see Section 9.4), due to the congested environment at each of the relevant locations, the possible range achieved was strictly limited. Even had this not been the case, a 'catch-22' situation had arisen. In order to ensure accurate estimation of each deceleration characteristic, as associated with each of the range of different types of 'model' solid, it was imperative that the flattest gradient employed, for each particular solid type, be such as to reduce solid velocities considerably, almost to the point of deposition, within the appropriate length of monitored pipework. However, due to the risk of blockage

development downstream of the monitored pipework, as previously discussed, no such arrangement could be allowed 'on-site'.

That all 'calibration' tests had now to be performed at each of three different gradient settings, meant that a very minimum of 960 individual 'model' solids would have had to be introduced, into the 'live' system, in order to complete the test series, (4 appliances x 4 types of 'model' x 3 gradients x 20 flushes per test). Irrespective of either the particular gradient to which monitored pipework was adjusted, or the conformation of the particular 'models' selected, the introduction of this number of sanitary protection products, over a relatively short period, would inevitably have caused havoc in the 'live' service system downstream. Also, in view of the time required, firstly, to readjust pipe gradients (which would have involved 'breaking' into the system) and, secondly, to perform the actual tests, it would have been necessary for each of the facilities under investigation to be closed to the public for unacceptably long periods.

Thus, it can be seen that the initial 'calibration' tests were both extremely useful, and yet, unsuccessful. Extremely useful, in that they directed attention toward aspects of the mode of waste solid transport which had hitherto not been appreciated, and thereby allowed the development of a much more reliable method for the estimation of waste solid deceleration characteristics. Unsuccessful, in that, having identified the inadequacies of the intended 'calibration' test series, and due to overwhelming extraneous limitations to the performance of 'site' operations, it was not possible to implement more appropriate procedures.

The results of the calibration tests conducted, as previously mentioned, and as presented in Figures 10/105 and 10/106, are therefore not sufficiently comprehensive to allow accurate estimation of the associated solid deceleration characteristics. For this reason, it would serve little purpose to attempt such estimation. However, certain observations can usefully be made, although it should be borne in mind that, as discussed in Section 10.3.1.2, the Panty-Shield 'model' solids displayed much greater variability of performance, in any given situation, than did the Mini-pad 'model' solids, and as such, must be considered a less

reliable indicator of real difference between systems. Taking the average, of the proportional difference at each of the nine velocity measurement 'points', values of standard deviation of velocity were from 70% to 120% larger, according to situation, for the Panty-shield 'model' solid.

It is immediately apparent, from Figures 10/105 and 10/106, that, for any particular arrangement of system geometry, the average velocity profiles of the two different types of 'model' solid are extremely similar. That this was the case was considered unfortunate, as the two 'models' were specifically selected with the intention that, in any particular situation, each type should perform somewhat differently. This provides a clear example of the substantial errors possible in assessment of solid deceleration when overriding modulative performance is not taken into account, the true mode of waste solid transport not having been appreciated at the time of 'model' selection. Simple differences between the predominant modulative patterns, displayed by those average velocity profiles achieved during laboratory based A.S.P.M. tests, were taken for real differences between deceleration characteristics.

From comparison between results achieved in the laboratory and results achieved from each of the 'on-site', 'main-line' (as opposed to 'branch-line'), test arrangements (W.C.3. at the female facility and W.C.5. at the male facility), it is apparent that the 'on-site' installations gave rise to substantially more efficient solid transport. This conforms to expectation, as previous analyses of 'W.C. design', 'W.C. orientation' and 'pipe-drop' (Sections 10.3.2.2., 10.3.2.3.1 and 10.3.2.3.2, respectively), all of which parameters were at variance between the 'site' and 'laboratory' installations, had suggested the particular differences, in each of the three parameters, to better promote solid transport at the 'on-site' facilities.

The question then arises, as to whether or not, any real difference can be detected between results collected at each of the two different 'main-line', 'on-site' installations, (while only considering that straight length of male facility pipework prior to the incorporated 92½° bend).

In respect of 'W.C. Orientation', and as outlined in Section 10.3.2.3.1, the female installation (W.C.3.) is thought to have held a very minor advantage over the male installation (W.C.5). Although a directly proportional relationship would not be expected, between orientational displacement of W.C., from the 'line' of connecting 'horizontal' discharge pipework, and the resulting variation in waste solid performance, some measure of this advantage can be taken from the fact that, while the orientation of W.C.3 is thought to have been ideal, the orientation of W.C.5 was only 5° at variance to that of W.C.3. In respect of 'pipe-drop', and as outlined in Section 10.3.2.3.2, a reverse advantage is thought to have existed , the 'pipe-drop' associated with W.C.5. being 11.3 % greater than that associated with W.C.3. Bearing in mind both the nature of the two parameters concerned, and the particular differences existing in this case, although no quantitative evidence is available to support this position, it is suggested that the 'pipe-drop' advantage of W.C.5 would have outweighed, probably by a proportionally significant amount, the 'W.C. Orientation' advantage of W.C.3. None the less, it would not be expected that variations in solid performance, resulting directly in consequence of either particular difference in system geometry, would be anything other than very small, when viewed in relation to absolute values of solid velocity.

The results of the 'Panty-shield' calibration tests, as presented in Figure 10/105, seem to suggest the possibility that, of the 'models' discharged via W.C.s 3 and 5, those from W.C.3 were more efficiently transported. This result would contradict theoretical expectation. On the other hand, the results of the 'Mini-pad' calibration tests, as presented in Figure 10/106, which, as previously discussed, were considered the more reliable, raise no intimation of the two installations being anything other than directly comparable. However, as previously outlined, the calibration tests actually performed were somewhat less than sufficient to allow accurate estimation of the associated deceleration characteristics. As this was the case, and in view of the theoretical analyses outlined, it is not suggested that these two installations, in respect of solid performance, may be considered directly comparable. It is suggested that, since the particular geometric differences, between the two installations under discussion, were relatively minor, the resulting variations in solid performance were also minor, and in consequence, given the limitations

of the available data, could not be detected. Thus, in comparison of 'live' waste solid velocity data between these two different installations, relatively minor variations in performance may not be attributed to anything other than differences of 'system' geometry. However, such geometric differences could not be held responsible for any significant disparity between results.

It can also be seen, from Figures 10/105 and 10/106, that those 'on-site' appliances which were connected, to the relevant main straight length of discharge pipework, via a 135° 'horizontal' entry branch inlet (W.C.2. at the female facility and W.C.6. at the male facility), gave rise to substantially less efficient solid transport than did those appliances connected directly to the relevant main straight pipework (W.C.3. and W.C.5.).

Prior to more detailed examination of this phenomenon, it should be mentioned that, since individual 'pipe-drops' in the 'site' environment were not adjustable (Section 10.3.2.3.2), and since the vertical position of each 135° connector was totally dependent upon that gradient set up on the associated main straight length of discharge pipework, the gradient of that short 'leg' of pipework between each 'branch' W.C. pan (W.C.2: and W.C.6.), and its associated main straight length of pipework, could not be controlled. This gradient, in each case, was somewhat steeper than that set up on the associated main length of pipework. The relevant solid velocity 'profiles', relating to both 'live' and 'model' loads, have been adjusted accordingly. This adjustment was achieved simply by replacing the term ' $\sqrt{L/G}$ ', in the equation ' $V = C1 - C2\sqrt{L/G}$ ', by the term:

$$\sqrt{(L1/G1) + (L2/G2)}$$

where:

L1 = that length of pipework adjusted to gradient 'G1'.

L2 = " " " " " " 'G2'.

L1 + L2 = total distance from W.C..

G1 = initial gradient.

G2 = subsequent gradient.

Returning to consider the relatively less efficient performance of solids discharged via 'branch-line' W.C.s, as compared to that of solids discharged via directly connected 'main-line' W.C.s, it is suggested that each of three different parameters may be held partially responsible. In respect of 'W.C. Orientation', and as outlined in Section 10.3.2.3.1, the 'main-line' W.C., at the female facility, held a 45° advantage over its 'branch-line' counterpart. A similar 'main-line' advantage, of 48° , existed at the male facility. In respect of 'pipe-drop', and as outlined in Section 10.3.2.3.2, each 'main-line' W.C. held a further advantage over its associated 'branch-line' W.C., main-line pipe-drops being the greater (by 4.4% at the female facility, and by 2.8% at the male facility). The two variables mentioned, namely 'W.C. Orientation' and 'pipe-drop', have each been discussed, in Section 10.3.2.3, in relation to their respective effects upon waste solid transport. However, despite the fact that the particular differences between 'main-line' and associated 'branch-line' installations, in respect of each of these variables, served to impart cumulative advantage to the former, from consideration of both the nature of the two parameters concerned, and the particular differences in each, it was not thought possible that these factors alone could have been responsible for the considerable disparity observed at each facility. A third contributory factor, being a rather obvious one, and one which has not yet been fully considered, is thought to have been the 45° change of direction, at the 135° junction, in each 'branch-line' installation.

That a third factor, other than 'W.C. Orientation' and 'pipe-drop', served significantly to retard 'branch-line' waste solid transport, can be illustrated through a simple comparison. As previously outlined, calibration tests were also conducted at the A.S.P.M. laboratory installation, and the results of these are included in Figures 10/105 and 10/106. It can be seen that the overriding modulative pattern, on the average 'Mini-pad' velocity profile, is one of considerable amplitude and extended wavelength. For this reason, it would be extremely difficult to hazard a guess at the associated deceleration characteristic.

However, even assuming the worst possible interpretation of this data to be correct, the efficiency of waste solid transport, at the laboratory installation, could only be judged to approximate that at the 'on-site' 'branch-line' male facility installation (while only considering that length of male facility pipework prior to the incorporated 92½° bend). In fact, from evaluation of 'Panty-shield' performance, it would seem highly probably that, of the two, the laboratory installation served to promote the more efficient solid transport. On the other hand, while discounting the possibility that the junction could have any lasting effect, beyond its own immediate vicinity, upon 'branch-line' waste solid performance, evaluation of the remaining differences in 'system-geometry' between these two installations would suggest that, of the two, the 'on-site' 'branch-line' male installation should have served to promote by far the more efficient solid transport. This 'branch-line' installation employed a more efficient type of W.C. pan (an un-vented V1206 S-trap W.C. pan, as compared to a vented B.S.1213 P-trap W.C. pan), as can be seen from Figure 10/88, which itself held a 127° advantage, in respect of 'W.C. Orientation' (Section 10.3.2.3.1), over that employed at the laboratory installation, as can also be seen from Figures 4/6 and 9/14. Furthermore, a significant advantage was held in respect of 'pipe-drop' (Section 10.3.2.3.2), which was 52.7% greater at the 'branch-line' installation (458 mm./300 mm.). Although there were further differences in respect of 'cistern/flush-pipe geometry', it can be seen, from Section 10.3.2.4, that these could not possibly have effected mean solid velocity results by anything but the most insignificant amount.

Thus, while discounting the possibility that the junction could have any lasting effect, beyond its own immediate vicinity, upon 'branch-line' waste solid performance, all indications are, that the male 'branch-line' installation should have promoted far more efficient solid transport than the laboratory installation. Taking this even further, from consideration of the particular differences in 'system-geometry' between these two installations and the 'main-line' installations, it could logically be concluded that the advantage displayed by the male 'branch-line' installation, over the laboratory

installation, should have been considerably greater than that displayed by each 'main-line' installation over its associated 'branch-line' installation. However, as the male 'branch-line' installation actually proved to promote no more efficient solid transport than did the laboratory installation, it can only be concluded that the sole remaining difference in 'system-geometry', namely the change of direction at the 135° junction, caused 'branch-line' solid transport, at all points downstream of the junction, to be significantly less efficient than would otherwise have been the case. Thus, the greater part of the difference in solid performance, observed between each 'main-line' and associated 'branch-line' installation, can be attributed to the associated 135° junction, which, in each case, served to inhibit the passage of 'branch-line' flows. This finding is in direct contradiction to the conclusions of previous research work.

In his study of the effects of bends and junctions upon 'model' waste solid transport (Section 2.2.2), Wakelin (1978) concluded that any such fitting caused rapid solid deceleration immediately downstream of the fitting, followed by a period of velocity regain. It was also suggested that, after this period of regain, solid velocity was once more at that level which would have been attained had the bend or junction not been traversed (that level predicted by the equivalent straight pipe 'linear' deceleration characteristic). The typical length of pipework, downstream of the fitting, over which solid velocity deviated significantly from the appropriate straight pipe deceleration characteristic, was estimated to be less than five metres for the majority of the range of different bends and junctions tested. Thus, it was further concluded, that only when a bend or junction was situated within that five metre length of pipework (or some other specific distance, as appropriate to the particular fitting), immediately prior to the point at which the equivalent straight pipe deceleration characteristic would suggest 'zone 2' flow conditions to terminate, would restoration of the efficiency of solid transport, to that of an equivalent installation incorporating no such bend or junction, not be assured.

To clarify the situation in respect of bends and junctions, some theoretical consideration of the matter is required. It is only reasonable to

assume that, in traversing a bend or junction, and as a direct result of the resistance of the fitting to continuation of the linear course, waste water loses a proportion of its 'stored' energy. Irrespective of whether or not a waste solid, being transported via such a route, suffers any similar direct loss of energy at the fitting, its overall performance must inevitably prove less efficient than would have been the case had no fitting been traversed. Any disparity which might be set up between the velocities of waste solid and surrounding water, subsequent to a bend or junction, could only result in there being a momentum transfer, to or from the solid, which would be the initial step in a new pattern of 'modulative' interaction (between the solid and surrounding water), which would itself decay, and thereby serve gradually to erode the disparity. Thus, even if a waste solid were to suffer no direct loss of energy at a particular fitting, due to the net loss of energy from the 'total' system, it would subsequently lose energy to the surrounding water as the natural balance of the 'total' energy system were restored. As previously outlined, in Section 10.3.2.3.2, the point at which all stored energy has been dispelled, and at which solid transportation becomes totally dependent upon 'static' forces, marks the end of that flow condition formerly described as 'zone 2'. Thus, it can be seen that, as there is a direct balance between the 'stored' energy of a waste solid and that of its surrounding water, the inevitable loss from the 'total' energy system, at a bend or junction, must result in premature termination of the 'zone 2' flow condition.

That solids display rapid deceleration immediately downstream of a fitting, followed by a period of velocity regain, is a clear indication that a considerable disparity is normally set up, in response to the fitting, between the velocities of solid and surrounding water. Were solids less susceptible than surrounding water to direct energy loss at a bend or junction, the initial solid deceleration would be far less rapid than was observed to be the case, each solid gradually decelerating as it encroached upon the preceding water. The observed rapid deceleration is, in fact, symptomatic of the greater susceptibility of solids as compared to surrounding water, to direct energy loss at a bend or junction. As flow observations, both 'on-site' and in the laboratory, had earlier identified the dramatic and inhibiting effects of direct contact between solid and pipewall, which contact could not be easily avoided in traversing a bend or junction, such a result was not unexpected.

That Wakelin (1978) identified no reduction in the efficiency of solid transport, during tests which incorporated a bend or junction, can easily be explained within the theory of 'modulative deceleration' (as initially outlined in Section 10.3.1.2, and as further developed in subsequent Sections). As has already been mentioned, the fluctuations in solid velocity, immediately downstream of a bend or junction, occur in response to a substantial disparity, caused by the fitting, between the velocities of solid and surrounding water. The modulative pattern of solid deceleration, from such a fitting onward, is therefore one of considerable initial amplitude. Thus, the value of velocity, at that point where the first subsequent modulation peaks, is far greater than that which would fall on the associated deceleration characteristic, about which these post-fitting modulations are centred. Wakelin (1978) found the initial peak value of velocity, downstream of a bend or junction, to be of the same order as that predicted by the equivalent straight pipe deceleration characteristic, but did not appreciate that this was merely a local peak value. As can be seen from Figure 10/107, (which presents a typical selection of the results achieved by Wakelin (1978) in his study of bends and junctions), no velocity measurements were taken at any point further downstream of the fitting than that at which the initial modulative peak occurred. Had a greater length of pipework been monitored, subsequent complete modulations would have become apparent, and the reduced efficiency of solid transport would have been obvious.

Were such energy losses, as occur at a bend or junction, in direct proportion to the mean velocity, at the bend or junction, of each of the traversing waste substances (whether solid or liquid), and therefore inversely proportional to the associated value of $\sqrt{L/G}$, it could only be concluded that, all other factors being equal, losses would increase (and the value of $\sqrt{L/G}$, at which the 'zone 2' flow regime terminates, would be reduced), as either gradient was increased or the fitting was moved closer to the W.C. discharge. However, it may reasonably be assumed that such energy losses are much more closely in proportion to the square of the mean velocity, at the bend or junction, of each of the traversing waste substances. Thus, the value of $\sqrt{L/G}$, at which the 'zone 2' flow regime terminates, is even more highly

dependent upon both gradient and position of fitting. That this was indeed the case, would account for the much greater than expected reduction in solid performance, at each 'branch-line' 'on-site' installation as compared to its associated 'main-line' installation, the high values of waste flow velocity in close proximity to the W.C. discharge, combined with the very short distance between each 'branch-line' W.C. pan and its associated 135° junction, causing more substantial losses at the junction than would have been the case had this separation been increased.

The differences in system geometry between the male and female 'branch-line' installations (in respect of 'W.C. Orientation' and 'pipe-drop'), were of the same order as those between the male and female 'main-line' installations. However, whereas no obvious difference was apparent between model solid performance as recorded at each of the two 'main-line' installations, the information presented, in Figures 10/105 and 10/106, seems much more strongly to suggest that the male 'branch-line' installation did indeed promote slightly less efficient solid transport than its female counterpart. In light of the previous assessment in respect of 'bends and junctions', three other factors can now be identified which would each have served to further reduce the efficiency of solid transport at the male 'branch-line' installation. Firstly, and as outlined in Section 9.4.3, due to limited 'floor-void' accommodation, it was necessary to incorporate a 13° change of direction (167° bend) prior to the 135° junction at the male 'branch-line' installation. Although this was only a minor change of direction, it must, none the less, have formed some impediment to waste flows. Secondly, the 135° junction, at the male facility, was approximately 160 mm, closer to the associated 'branch-line' W.C. pan than was the case at the female facility (see Figures 9/14 and 9/15), and must therefore have given rise to greater energy loss. Thirdly, male facility calibration tests were conducted at gradient 1:150, while comparative female facility tests were conducted at gradient 1:200. The steeper gradient, at the male facility, must therefore have given rise to greater energy loss at the 135° junction.

In respect of solid performance downstream of the 92½° bend, as incorporated into the male 'on-site' installation, it can only be reported that this conformed to expectation. In light of current understanding, with regard to the mode of waste solid transport, and the adjustments to this which ensue beyond any bend or junction, it is retrospectively apparent that the limited data recorded downstream of this 92½° bend, relating to both 'model' and 'live' waste solids, is of little practical use. The bend was initially installed in an attempt to maximise upon the length of male facility pipework available for scrutiny, as the congested local environment precluded the possibility of installing a comparative length of straight pipework. Had Wakelin's (1978) analysis of bends and junctions been correct, velocity data, recorded at some distance downstream of the bend, could have been considered to approximate that which would have been achieved had no bend been traversed. As this analysis is no longer thought to be correct, the data recorded beyond the bend may not be considered an indicator of equivalent straight pipe deceleration, nor is it sufficiently comprehensive to allow numerical analyses of performance subsequent to a bend.

As was outlined in Section 10.3.2.1, it is necessary to perform at least three different gradient tests, in any one series (with otherwise identical system geometry and solid type), in order to attain an accurate estimate of the associated 'linear' deceleration characteristic. Ideally, four or five different gradients would be employed. However, as has already been discussed, all indications are that, for a particular installation incorporating a particular bend or junction (at a fixed distance from the W.C. discharge), the 'post-fitting' deceleration characteristic (that associated with performance subsequent to the fitting), for any particular solid type, will vary according to gradient. Each different gradient test performed at such an installation would be attempting to estimate a different 'post-fitting' deceleration characteristic. Thus, any series of tests which might be performed, in order to assess the effect of a particular bend or junction upon the performance of a particular solid type, would have to be carefully arranged. The need to conduct several different gradient tests could not be avoided, and in fact, as the length of pipework available for scrutiny would be particularly limited (since it would only be valid to consider

solid performance between the fitting and the point of termination of the 'zone 2' flow regime), it might prove necessary to conduct a very minimum of four or five different gradient tests in any one series.

A best approach, to ensure that the 'post-fitting' deceleration characteristics were the same at each gradient (in other words, to ensure that the mean loss of energy from the 'total' system, at the bend or junction under investigation, were held constant throughout the different gradient tests), would require that the mean velocity of waste flows (both solid and liquid), at the point of the fitting, be maintained at a selected value throughout. This could be achieved by repositioning the fitting prior to each different gradient test, to maintain the value of ' $\sqrt{L/G}$ ', associated with the position of the fitting, at the appropriate constant value throughout. Having estimated the deceleration characteristic associated with a particular fitting, and a particular mean waste velocity at the fitting, this could be compared to the equivalent straight pipe deceleration characteristic. It would then be necessary to investigate the effects of the fitting when positioned at several different values of ' $\sqrt{L/G}$ ', and for each different value a complete series of similar tests would have to be performed. To complete a full study of bends and junctions, not only would a range of different fittings have to be investigated, but each would have to be tested with a range of different solid types.

10.3.3. Deceleration Characteristics.

In order to fully appreciate the mode of 'live' waste solid transport, and in particular the prevailing interactive mechanisms between associated solids in multi-solid flushes, (Section 10.3.1.3), it was necessary to monitor the performance of each individual solid, in each multi-solid flush, irrespective of either its particular type (re: material composition, dimensions etc.), or its relative position (re: the order of arrival of solids into the discharge pipework). However, as discussed in Section 10.2.3, any logical approach to the design of above ground drainage systems must be geared to the avoidance of solid deposition above an agreed 'safe-limit', (the level of which has yet to be determined). Thus, in the assessment of multi-solid flushes, it

is the performance of each trailing solid which, for all practical purposes, must be considered of prime importance. Furthermore, in order to reflect user activity, any good system design, for any particular facility, must take into account the proportional rate of occurrence of the different distinctive types of flush (Section 10.2.2). For this reason, in estimation of those deceleration characteristics associated with 'live' waste loads, the performance of solids discharged in 'faecal' flushes has been considered separately from that of solids discharged in 'non-faecal' flushes. Although the number of solids per flush varied considerably within each grouping, it was the performance of the trailing solid of each multi-solid flush, and that of the sole content of each single solid flush, which was considered to define the performance, for design purposes, of each total flush load.

10.3.3.1 Accuracy of Estimation.

As discussed in Section 10.3.2.1, it is apparent, from consideration of the modulative nature of solid deceleration, that an accurate estimate of 'linear' deceleration characteristic, as associated with a particular combination of 'model' solid and system geometry, can only be achieved from the results of several different gradient tests performed in otherwise identical circumstances. That this was the case, had not been appreciated prior to the 'on-site' investigations. The 'live' waste monitoring programme was therefore conducted with only a single change of gradient at the female installation (1:150 to 1:200); and no change of gradient at the male installation (1:150 throughout). None the less, even had the modulative nature of waste solid deceleration been appreciated, from the outset, it would not have been possible, in the time available, to incorporate a wider range of different gradient tests into the programme. As it was only to be expected that there would be considerable variation between the contents of different flushes (in respect of the number of solids discharged, the order of arrival of solids into the pipework, the material composition of each solid, the particular shape and size of each solid etc.), it was considered of paramount importance that a sufficient number of 'live' flushes be monitored, at each particular arrangement of system geometry (and for each particular connecting appliance), to ensure the achievement of a

representative sample of the 'parent population' of all possible different flushes. Of the 'on-site' facilities available for investigation, those employed displayed the highest levels of system usage (see Sections 9.1 and 9.2), and therefore, in order to allow investigation of 'live' waste performance over a wider range of gradients, the number of flushes monitored per test group would have had to be reduced, and the 'representative' nature of each sample would then have been brought into question.

As the modulative nature of solid deceleration became apparent, it was initially feared that the lack of a range of different gradient results, in respect of 'live' waste load performance, at each of the different 'on-site' installations, would seriously jeopardise successful assessment of that data which had been collected. However, as can be seen from the results presented in Figures 10/108 and 10/109, the modulative nature of solid deceleration had far less disruptive an effect, than might have been expected, upon the calculated mean velocity profiles of trailing 'live' waste solids. That result may be attributed to two different factors. Firstly, as it had been the wide variation in individual flush content which had made it necessary for each 'on-site' test to envelop a large sample of different flushes, so the achievement of a wide variation in sample flush content resulted in there being a similarly wide variation in associated 'live' waste transport performance, not only in respect of the particular 'linear' deceleration characteristic associated with each trailing solid, but also in respect of the pattern of modulative velocity variation about each such characteristic. Given the differences in amplitude, frequency, phase and rate of decay, between the modulative patterns displayed by individual trailing solids, in calculation of average velocity profiles, all such modulations were much more effectively cancelled out than would have been the case had less variation been displayed between the contents of different 'live' flushes. It must not be forgotten that, with different but identical 'model' waste solids, there is normally only limited variation between the modulative patterns displayed by different solids, and the 'linear' deceleration characteristic associated with each such solid is virtually unchanging. Secondly, and as outlined in Section 10.3.1.3, trailing solids were far less susceptible, than other solids in multi-solid

flushes, to the forces which promote modulative performance. Thus, as the modulations of individual trailing solids were relatively modest, the consequent interference to mean velocity profiles was not pronounced.

A reasonable if not precise estimate, of the mean 'linear' deceleration characteristic defining the transport of any particular sample of 'live' waste load trailing solids, could therefore be achieved from the results of a single gradient test, provided of course that a sufficient length of pipework had been monitored, and that the particular gradient was suitably chosen to maximise upon the proportion of 'zone 2' flow completed prior to system clearance. That this had proven to be the case was considered particularly fortunate as, from the results presented in Figures 10/108 and 10/109, it was also apparent that Wakelin's (1978) empirical equation for gradient (from use of which, the results of different 'model' solid transport tests, acquired at different gradient settings but in otherwise identical circumstances, may be rendered directly comparable), is not wholly applicable to 'live' waste solid transport (Section 10.3.3.3).

10.3.3.2 Dominance of Toilet/Tissue-Paper Solids.

As outlined, in the introduction to Section 10.3.3, the performance of 'faecal flush' waste loads (those which incorporated some recognisable faecal material, irrespective of amount, and which may or may not also have contained non-faecal material), was assessed separately from that of 'non-faecal flush' waste loads (those which incorporated no faecal material whatsoever, but which were composed entirely of non-faecal material). Although this approach was primarily adopted, in order to allow that the proportional rate of occurrence, of the different types of flush, could be taken into account in any future system design method (Section 10.3.3.5), there was the further advantage that 'non-faecal flush' results could be used as a control, in comparison against 'faecal flush' results, thereby allowing assessment of the effects upon overall waste load performance of the faecal component of 'faecal flush' waste loads.

For each of the six different 'on-site' test combinations of appliance and system geometry, Figures 10/108, and 10/109 respectively, present the average velocity profiles associated with the trailing solids of all successfully monitored 'non-faecal', and 'faecal', single flushes (as opposed to simultaneous discharges, defined in Section 10.2.1). From study of these Figures, overwhelming similarities are immediately apparent between the results achieved for both 'faecal' and 'non-faecal' flush waste loads. The only real difference, between these two sets of results, seems to be, that each mean 'faecal' flush velocity profile displays a somewhat steeper associated deceleration characteristic than does its comparative mean 'non-faecal' flush velocity profile. The inter-relationships displayed, between the various mean 'faecal' flush profiles, are almost exactly the same as those displayed between the comparative mean 'non-faecal' flush profiles. Further more, the modulative pattern (order of velocity variations about the associated 'linear' deceleration characteristic), displayed by each mean 'non-faecal' flush profile, is almost exactly reproduced, in every case, by the comparative mean 'faecal' flush profile.

Assessment of the toilet/tissue-paper component of 'live' waste loads, as outlined in Section 10.2.2.4, suggested that, irrespective of facility, the quantity of such material contained in the average 'faecal' flush exceeded that contained in the average 'non-faecal' flush. Also, and by definition, 'faecal' flushes each contained faecal material, whereas 'non-faecal' flushes did not. Thus, the total mass, of the average 'faecal' flush waste load, exceeded that of the average 'non-faecal' flush waste load. As has already been discussed in Section 6, it was found from laboratory investigations, which employed a sterile 'sanitary protection product' type of 'model' solid, that first and foremost, solid mass is fundamental to transport performance, overriding to a great extent the parameters of shape and size. It was therefore only to be expected, that the average 'faecal' flush waste load performance would be somewhat less efficient than that of the average 'non-faecal' flush waste load. The steeper deceleration characteristic displayed by each mean 'faecal' flush profile, as compared to that of its associated mean 'non-faecal' flush profile,

confirms that this was indeed the case.

That, apart from the lesser efficiency of mean 'faecal' flush waste load transport, no other significant variations in relative performance were apparent, is an extremely significant result from which several useful conclusions may be drawn. The almost identical inter-relationships displayed between the various mean 'faecal' flush profiles, as compared to those displayed between the comparative mean 'non-faecal' flush profiles, along with the near precise reproduction, on each mean 'faecal' flush profile, of the modulative variations manifested by the comparative mean 'non-faecal' flush profile, suggest that the faecal material component, of the average 'faecal' flush waste load, was of no real significance in determination of the 'mode' of total waste load transport (had this not been the case, the faecal component, at the very least, would have caused some variation in modulative performance). It follows, as a natural progression from the previous conclusion, that 'faecal' flush waste loads responded in exactly the same manner, to the particular variations in gradient and system geometry (between different test arrangements), as did 'non-faecal' flush waste loads, and that the proportional variation in mass, between the waste loads of the average 'faecal' and 'non-faecal' flushes, was of very much the same order at both male and female facilities (had this not been the case, then the inter-relationships displayed, between particular male and female mean velocity profiles, would not have been identical for both 'faecal' flush, and 'non-faecal' flush, waste loads.)

A further useful conclusion is that, although the achievement of a representative sample, for each test, of the particular 'parent' population of all possible different flushes, by no means pre-ordained that such similarities in performance, as have been outlined, would result, the very fact that, in all cases, such close correlation did result, may be taken as a clear indication, that any slight difference which may have existed, between the average load (of any particular sample), and the typical such flush load, had insignificant effect upon the resulting transport performance.

Examination of individual 'faecal' flush waste load performances, conducted to allow identification of the various interactive flow mechanisms prevalent in multi-solid waste flows (Section 10.3.1.3), had shown that, due both to generally greater mass, and substantially increased blockage factor, toilet/tissue-paper solids were dominant over faecal solids. The 'mode' of transport displayed by the average toilet/tissue-paper solid, discharged as part of a 'faecal' flush waste load, seemed almost totally uninfluenced by interaction with faecal solids, while the mode of transport displayed by the average faecal solid was obviously greatly influenced by such interaction. As solids virtually never bypassed one another, a dominant trailing solid ensured the progress of preceding solids. As it was the trailing solid of each flush which was considered of prime importance to practical definition of overall waste load performance, (which trailing solid was found to be of toilet/tissue-paper material in 88% of all mixed content 'faecal' flushes), it was expected that faecal influence, upon the 'mode' of overall 'faecal' flush waste load performance, would be minimal. However, the average 'live' waste velocity profiles, as previously mentioned, not only confirmed this as the general case, (faecal material serving merely as 'ballast', and thereby causing a reduction, in some proportion to the mass of total material, in overall levels of performance), but much more than this, suggested that no particular 'manner' of response, displayed by 'faecal' flush waste loads, to any specific detail of system geometry, could be attributed, in any way, to the presence of faecal material.

10.3.3.3 Mobile Nature of Toilet/Tissue-paper Solids.

To this point, all solid transport has been viewed in relation to Wakelin's (1978) empirical equation for gradient (as initially outlined in Section 2.2.2, and as discussed and developed throughout this work), which purports to define the relationship between pipe gradient and 'zone 2' solid deceleration, for any particular combination of solid type and system geometry. Although modulative velocity variations were found to occur (Section 10.3.1.2), about the 'linear' deceleration characteristic defined by Wakelin (1978), it can only be concluded, from study of all the available information, that, in respect of 'model' solid transport performance, Wakelin's (1978) equation is truly

applicable. However, from each of Figures 10/108 and 10/109 (which, for 'non-faecal' and 'faecal' flushes respectively, present the six different average 'live' waste 'trailing' solid velocity profiles, as associated with each of the six different 'site' combinations of appliance, system geometry and gradient), it is obviously apparent that, while the two average female 'branch-line' velocity profiles (which represent performance at each of gradients 1:150 and 1:200), display an inter-relationship of the type predicted by Wakelin's (1978) equation, the two comparable average female 'main-line' velocity profiles (which also represent performance at each of gradients 1:150 and 1:200), clearly display marked divergence from such an inter-relationship.

There could be no question that the unusual divergence from the expected relationship for gradient, observed in connection with the female 'main-line' installation, was anything other than both real and significant, as exactly the same situation was apparent from the average velocity profiles of both 'faecal' flush and 'non-faecal' flush wasteloads. Thus, the possibility was eliminated, that 'non-typical' mean flush content, over any particular test sample of flushes, could, in any way, have been either partially or totally responsible for this unexpected result (see Section 10.3.3.2). Similarly, since the phenomenon was equally apparent from 'non-faecal' flush waste load performance, the possibility that the root cause was in some way related to the presence of faecal material could also be eliminated (again, see Section 10.3.3.2). The only remaining possibility was that the marked divergence, away from the type of inter-relationship predicted by Wakelin's (1978) equation, was in some way caused by the toilet/tissue-paper component of waste loads, specifically, by some particular detail or property of that material not common to the sanitary protection product type of 'model' solid. Furthermore, as female 'branch-line' waste flows displayed total conformity to Wakelin's (1978) equation, it could only be concluded that some change or variation in the basic form or structure of the average toilet/tissue-paper solid, which occurred in response to variation in externally applied hydraulic forces (synonymous with variation in gradient), was either triggered by some particular detail of 'main-line' system

geometry, or suppressed by some particular detail of 'branch-line' system geometry.

In fact, the only property of the toilet/tissue-paper solid, which could possibly be held to account for this unusual aspect of transport performance, was first identified, as outlined in Section 10.2.2.4, during analysis of the subjectively assessed data relating to solid conformation. It was found that, in response to changes in the prevailing hydraulic forces, individual toilet/tissue-paper solids, having no definite structure, were subject to variations in both geometric form and 'state of compaction'. As both of the parameters, distance from input device, and pipe gradient, were instrumental in the determination of the prevailing levels of hydraulic forces, they must also have been instrumental to such variations in toilet/tissue-paper solid 'form.'

The 'mobility' of solid form, as outlined above, was identified from the results of a complete descriptive survey of average waste loads, as is presented in Figures 10/28 to 10/40 inclusive, which was compiled from observation of all monitored 'single' flushes (irrespective of whether or not individual flushes encountered previous stoppages already deposited in the discharge pipework), and which, although classified according to facility and gradient, took no account of the particular pipe-routes traversed. As outlined in Section 10.2.2, this comprehensive approach was adopted, primarily, to ensure the precise definition of the mean waste load associated with each particular combination of facility and flush type. Having obtained such a 'master' definition, it was intended that similar descriptive data be compiled for the constituent flush loads of each individual test 'sample' (of successfully monitored (re: solid velocity) 'single' flushes, of the same type ('faecal'/'non-faecal'), which did not encounter any previous deposits, and which traversed a particular pipe-route at a particular gradient setting). It was further intended that, through comparison of each 'sample' definition against its associated 'master' definition, identification of any particular instance of 'non-typical' mean 'sample' waste load could be achieved, thereby allowing a better appreciation of

mean 'sample' velocity profiles. However, as already discussed in Section 10.3.3.2, the mean 'sample' velocity profiles achieved, in the event, were to deny the possibility that any particular sample was anything other than truly representative of the relevant 'parent' population (of all possible 'single' flushes of the same type). It was therefore no longer necessary, for the purposes outlined, to evaluate the average descriptive definition of each individual test sample. That this proved to be the case was considered extremely fortunate, as the 'mobile' nature of toilet/tissue-paper solid 'form' would have rendered any such comparison as has been outlined (intended to assess the relative amounts of such material contained in different flushes), extraordinarily difficult, if not impossible. Nonetheless, given the fact of 'mobile' toilet/tissue-paper solid 'form', the only route to a better appreciation of the phenomenon was through comparative assessment, one to another, of the exact same descriptive definitions of individual 'sample' waste loads, as had originally been intended to allow investigation of the 'representative' standing of 'samples', as are presented in Figure 10/110.

As already discussed in Section 6, it was found from laboratory investigations, which employed sterile 'sanitary protection product' types of 'model' solid, that, first and foremost, solid mass is fundamental to transport performance, overriding to a great extent the parameters of shape and size. Increase in either length, width or thickness of solid, when combined with a proportional increase in total mass, caused an overall reduction in solid transport efficiency. However, the efficiency of solid transport was found to be far less effected by an increase in mass, manifested as an increase in solid length, than by a similar increase in mass manifested as an increase in either width or thickness of solid. It was further discovered that, for solids of identical mass, a long and thin solid performed better than a short and thick solid (of identical width), as did a long and narrow solid in comparison to a short and broad solid (of identical thickness). Although the objectives of this particular laboratory investigation were not achieved, in that the results attained proved less than sufficient to allow quantitative understanding (of the effects upon waste solid transport of the dimensional parameters of solids),

the qualitative information achieved, as outlined above, provided useful clues to the possible effects of 'mobile' solid form.

As no variations were apparent from observation in respect of toilet/tissue-paper solid width (either between different solids, or for a particular solid during the course of its transportation), it was considered reasonable to assume that, for all intents and purposes, the dimensional parameters responsible for the unusual performance of toilet/tissue-paper solids were those of length and thickness. However, the problem was further complicated by the fact that the toilet/tissue-paper solid, during transportation, was subject, not only to dimensional re-arrangement, but also to variations in its 'state of compaction' (analogous to saturated bulk specific gravity). Thus, it might reasonably be expected, that compaction of a toilet/tissue-paper solid, which might well occur as a direct result of some impact between itself and, for instance, the pipewall (as could happen at a bend or junction), would take the form of a quite obvious reduction in length, accompanied, not by a reduction in thickness, as all compressive forces would have been applied in the 'horizontal' plane ('horizontal', only if, in this respect, gradient is considered to be negligible), but rather, by a less obvious increase in thickness.

The laboratory study, referred to earlier in this Section, would suggest such 'compressive' re-arrangement of dimensional parameters to reduce the efficiency of waste solid transport, and such dimensional re-arrangement, combined with an increase in 'saturated bulk specific gravity', could only result in even greater loss of efficiency. However, the possibility must be considered, that compression by impact might not only 'concertina' the toilet/tissue-paper waste solid, as could well be the sole result of a minor increase in the general level of prevailing hydraulic forces (and from which would, the elastic properties of the solid could feasibly cause reversion, after alleviation of the compressive forces, to that form held prior to the onset of such forces), but might also re-arrange the basic conformation of the loosely-structured 'composite' toilet/tissue-paper solid, thereby precluding the possibility that the solid could be restored to its former condition by means of

elastic expansion. Although a 'sanitary protection product' type of 'model' solid (as used in the laboratory investigation previously referred to), in negotiating a similar fitting, could equally well be somewhat compressed, such a solid, having specific form and structure (being a fixed-construction composite solid, as opposed to a loose-construction composite solid), could only be compressed in a 'concertina' fashion, from which mould, after alleviation of the compressive forces, it could feasibly revert to its previous form.

Expansion of a toilet/tissue-paper solid, which is believed to be the response of such a solid to a reduction in the general level of prevailing hydraulic forces, might reasonably be expected to take the form of an increase in both length and thickness, combined with a reduction in 'saturated bulk specific gravity'. The laboratory study, referred to earlier in this Section, would suggest the efficiency of waste solid transport to be improved, when, for no change in total mass, an increase in length is combined with a reduction, rather than an increase, in thickness. However, such analysis presumes no variation in 'saturated bulk specific gravity'. It would seem only logical that, when, for no change in total mass, an increase in length is combined with an increase in thickness, thereby effecting a reduction in 'saturated bulk specific gravity', improved blockage factor, improved flotation and a reduction in the ratio of solid weight to basal pipe area, must all result. These adjustments to solid form could only serve to improve the efficiency of waste solid transport.

It has been suggested, to this point, that expansion of a toilet/tissue-paper solid occurs in response to alleviation of compressive forces, and by means of the inherent elasticity of the solid. However, this explanation cannot be wholly correct. Shear forces are applied, to any solid in normal 'straight-pipe' deceleration, by means of the gradual 'by-pass' of water over and around the solid, and given the situation of an alleviation of compressive forces, such shear forces could only serve to promote solid expansion. Although the rate of 'bypass' of following water is dependent upon a multitude of parameters, relating to both system geometry and solid form, solid blockage factor must be considered to be of particular relevance. For a solid, such as the toilet/tissue-

paper solid, which forms a substantial obstacle to following water, the rate of 'bypass' is extremely low in all but exceptional circumstances (one such being the occasion of a stationary solid, picked up by a subsequent discharge). Thus, those shear forces, which occur during normal deceleration, can only be considered to be of minor significance. As regards the elasticity of toilet/tissue-paper solids, this must vary somewhat according to the type and manufacture of paper. The toilet/tissue-paper provided was of the grease-proof type, but, as discussed in Section 10.2.2.3, a number of solids were identified as being composed of other types of toilet/tissue-paper, and whereas the grease-proof type of paper displays definite elasticity, many of the 'soft' varieties of paper appear to be almost in-elastic.

As already discussed, the application of significant compressive forces, to a toilet/tissue-paper solid, might not only 'concertina' the solid, but also re-arrange its basic structural conformation. After alleviation of such compressive forces, any inherent elastic properties of the solid would serve to restore the solid, at least in part, from a 'concertina' mould to the rather more extended form previously held, but would not, in any way, serve to assist reversal of any structural re-arrangement effected through compression. The shear forces, resulting from the gradual 'bypass' of water, would assist inherent elasticity in the restoration of an extended form, or, given an in-elastic solid, would alone effect partial restoration. However, were either or both of the forces discussed, to promote full extension from a concertina mould, it is considered most unlikely that continued application of shear forces would achieve any further extension of the solid, as far more significant expansile forces would be required to effect the prerequisite re-arrangement of basic structural conformation.

As, in respect of waste solid transport, no expansile forces other than those outlined exist, it can only be concluded; firstly, that, for any particular toilet/tissue-paper solid, there is a definite limit to the amount of expansion possible (being that point at which, to achieve further expansion, re-arrangement of the component parts of the solid would be required); secondly, that toilet/tissue-paper solids must arrive in the discharge pipework in a somewhat compressed 'concertina' condition (as such solids would not have been capable of expansion if,

on arrival in the discharge pipework, they were already fully extended, and as it has already been shown, in Section 10.2.2.4, that such solids were capable of expansion), which condition must result in response to the resistance to linear transportation encountered in negotiation of both the W.C. pan and the various fittings at inlet to the discharge pipework, and which condition is either maintained, enhanced or alleviated, according to the prevailing hydraulic forces applied during subsequent deceleration; thirdly, that any re-arrangement of the component parts of a toilet/tissue-paper solid, which might occur through the application of compressive forces, could not be reversed by means of any of the forces which could subsequently prevail.

As previously mentioned, information is presented, in Figure 10/110, which relates to the apparent mean size of the toilet/tissue-paper component of each successfully monitored 'sample' of waste loads (as associated with each 'on-site' combination of facility, pipe-route, gradient and flush type), and which includes both mean 'length' data (mm.) and mean 'thickness' data (scalar- see Section 10.2.2.4). However, throughout consideration of this information, it must be borne in mind, that the observation point at the female facility was much further removed from the associated W.C.s than was the case at the male facility. As solid expansion is believed to be dependent upon the general level of prevailing hydraulic forces, and therefore also dependent upon distance travelled, this means that descriptive information, relating to one facility, may not be considered directly comparable to similar data relating to the other facility.

It can be seen, from Figure 10/110, that the four female 'non-faecal flush' test samples, which together comprised only one third of all the different test samples, between them accounted for over 72% of all successfully monitored appropriate flushes, each such sample having been, on average, more than five times larger than each of the other eight samples. For this reason, the descriptive solid data relating to these four female 'non-faecal flush' test samples could only be considered as by far the most 'representative' of all such available data, and therefore, throughout the following comparative assessment of descriptive toilet/tissue-paper data, all discussion, except where specifically stated to the contrary, relates to these four test samples.

With reduction in gradient at the 'main-line' installation, from 1:150 to 1:200, the average length of material per flush increased by 14.1%, while mean solid thickness increased by 6.1%. This appears to confirm theoretical deductions, suggesting that greater or more rapid expansion occurs with reduction in the general level of prevailing hydraulic forces (as induced, in this case, by reduction in gradient). Similar values, suggested by comparative assessment of the associated female 'faecal flush' samples, were a reduction of 6.8% ('length') and an increase of 4.3% ('thickness') respectively. This seems to indicate that, in respect of 'thickness', the smaller flush samples were indeed 'representative', whereas in respect of 'length', they were not. Nonetheless, some question must also be raised as to the 'representative' nature of even large flush sample 'length' data, which question can only be determined on the balance of evidence to emerge from further such comparisons.

At the 'branch-line' installation, and at gradient 1:150, the average length of material per flush was 8.2% smaller, and mean solid thickness was 1.8% greater, than was the case at the 'main-line' installation at the same gradient. It must not be forgotten here that, due to environmental restrictions 'on-site', the short 'leg' of pipework, prior to the 135° junction on each 'branch-line' installation, was, in all cases, at a somewhat steeper gradient than the subsequent straight length of discharge pipework (see Section 10.3.2.6). Assuming expansion to be a continuous process, this would have served both, to reduce the rate of 'branch-line' expansion prior to the 135° junction (thereby reducing the rate of increase of both 'length' and 'thickness' of toilet/tissue-paper material), and to increase compaction at the 135° junction (thereby causing both greater reduction of 'length' and greater increase in 'thickness'), as compared to the situation which would have resulted had the complete 'branch-line' system been at gradient 1:150. Thus, it can only be concluded that, had there been complete continuity of gradient throughout, 'branch-line' results, in comparison against 'main-line' results, might have displayed a reduction in 'length' of something less than 8.2%, and an increase in 'thickness' of something approximating 1.8%. None the less, these results appear to confirm theoretical deductions, suggesting that significant compaction occurred in negotiation of the 135° branch-entry to the main straight length of discharge pipework.

Similar comparisons, of 'branch-line' data as to 'main-line' data at gradient 1:150, for female 'faecal flush' test samples, male 'faecal flush' test samples and male 'non-faecal flush' test samples, suggest variations in 'average length of toilet/tissue-paper material per flush' of +13.2%, +11.0% and -16.0% respectively, and variations in 'mean toilet/tissue-paper solid thickness' of +0.9%, +2.3% and +3.3% respectively. Again it would seem that, although the 'thickness' data of the smaller flush samples roughly reflects that of the larger flush samples, considerable disagreement is displayed, between the different small samples, as to the variations in 'length' which occurred. As the 'length' data of the larger flush samples appears to comply with theoretical expectation, it can only be concluded that variations displayed by the smaller flush samples do, in fact, reflect real variations in the average amount of toilet/tissue-paper material per flush. That this was the case was of particular interest, as no variation in performance was apparent, from the resulting mean sample velocity profiles, which could possibly be attributed to 'non-standard' mean sample flush content (see Section 10.3.3.2).

From the outset, of 'on-site' investigations, it had been foreseen that a possible unfortunate outcome might be that, for one or more of the different sample tests, 'non-standard' trailing solid transport might occur, and be detected, while the fact of 'non-standard' mean sample waste load composition might prove impossible to detect from the associated descriptive information. In the event, at least in respect of the smaller test samples, exactly the opposite situation appears to have occurred. That this proved to be the case, raises a further important question. As average small sample 'trailing solid' velocity profiles conformed almost exactly to expectation (in-line with those of large samples), while associated variations in 'mean length of toilet/tissue-paper material per flush', attributable to real variations in the average amount of material per flush, were of the same order as 'length' variations attributable to either expansion or compaction, why then did expansion and compaction have such significant effect upon transport performance? It can only be concluded, that it is not the actual 'length' adjustment, resulting from expansion or compaction, which is of particular importance to subsequent transportation, but rather, it is the simultaneous variation in either or both of 'thickness' and 'saturated bulk specific gravity.'

With reduction in gradient at the 'branch-line' installation, from 1:150 to 1:200, the average length of toilet/tissue-paper material per flush increased by 12.9%, while mean solid thickness increased by only 0.7%. Assuming negotiation of the 135° branch inlet, to the straight length of discharge pipework, to have had no irreversible effect upon toilet/tissue-paper waste solids (in other words, assuming the rate of expansion, which occurred subsequent to compaction, to have been of the same order as that which would have occurred had no junction been traversed), it might have been expected that the proportional increase in size, resulting with reduction in gradient, would have compared to that observed at the 'main-line' installation (14.1% increase in length, and 6.1% increase in 'thickness'). However, this would assume a similar amount of 'compaction' to have occurred, at the 135° junction, at both of gradients 1:150 and 1:200, whereas, in fact, less compaction would have occurred at the flatter gradient. From the comparison between 'branch-line' and 'main-line' installations, at gradient 1:150, it was suggested that 'branch-line' compaction accounted for an 8.2% reduction in 'length', and a 1.8% increase in 'thickness'. To over-estimate the reduction in compaction, resulting with reduction of 'branch-line' gradient, let it be assumed that, at gradient 1:200, these values would have been 4.1% and 0.9% respectively. Continuing to assume 'compaction' to have had no irreversible effect, these values would suggest that the proportional increase in size, resulting with reduction in gradient at the 'branch-line' installation, should have been of the order of a 19.2% increase in 'length' ($(114.1 \times ((100-4.1)/(100-8.2))) - 100$), and a 5.2% increase in 'thickness' ($(106.1 \times ((100.9)/(101.8))) - 100$).

Thus, it can be seen that, with reduction of gradient at the 'branch-line' installation, an increase in 'length' of at least 14.1%, but of no more than 19.2%, might have been expected, as an increase in 'thickness' of at least 5.2%, but of no more than 6.1%, might also have been expected. As the actual increases, in each of 'length' and 'thickness', proved to be 12.9% and 0.7% respectively, it can only be concluded that, while the rate or amount of 'length' expansion (or the increase in rate, or increase in amount, of 'length' expansion), which occurred in response to reduction in gradient, was only marginally reduced in consequence of

previous 'compaction', the rate or amount of 'thickness' expansion (or the increase in rate, or increase in amount, of 'thickness' expansion), which occurred in response to reduction in gradient, was substantially reduced, if not quite totally eliminated, in consequence of previous 'compaction'.

As has already been discussed, variations displayed, in comparison of 'small' sample 'length' data, are not solely indicative of either expansion or compaction. Thus, any further such comparison would serve no purpose. However, to this point, no reason has emerged to suggest the same to be true of 'small' sample 'thickness' data. Comparison of the 'small' female 'faecal flush' test samples suggests that, with reduction of gradient at the 'branch-line' installation, 'thickness' was reduced by 0.4%, whereas the associated value for the 'main-line' installation was an increase of 4.3%. Considering the minute size of the suggested reduction in 'thickness', this data can only be taken as an indication that no increase in 'thickness' occurred with reduction in 'branch-line' gradient, whereas an obvious such increase occurred with similar reduction of 'main-line' gradient. These results therefore seem to confirm the conclusions drawn from 'large' sample data.

The comparisons, between different flush samples, conducted to this point, of the average dimensional conformation of the toilet/tissue-paper component of sample flush content, being fraught with complications, can only be considered as far from precise. Specific complications were; that all waste solid descriptive data was subjectively achieved (see Section 10.2.2.1); that in each case, observations as to solid conformation were not made at any precise point, but rather, over a general area of pipework; that, as the number of flushes which could be grouped together, into any one sample of 'like' flushes, was strictly limited (despite the fact that, in total, 2,668 individual 'live' W.C. discharges were monitored), there was an ever-present possibility of slightly 'non-standard' (or 'un-representative') mean sample flush content; that values of mean 'thickness', for toilet/tissue-paper solids, could only be achieved on a non-dimensional basis (see Section 10.2.2.4); that, assuming 'representative' mean sample content, an increase (displayed by one 'sample' over another 'sample') in mean toilet/tissue-paper solid

'thickness' may, according to situation, be indicative either of greater expansion or of greater compaction (determination being made as to which has occurred on the basis of the associated mean 'length' variation).

Nonetheless, as can be seen from the comparisons already presented, the descriptive toilet/tissue-paper 'sample' data, in the most part, does confirm theoretical expectation, in respect of both the causal parameters of expansion and compaction, and the manner of solid response to the application of either expansile or compressive forces, and that this proved to be the case can only be considered as most encouraging. This is particularly true as the most apparent and least questionable result, namely the dampening effect of the 135° junction upon 'branch-line' 'thickness' expansion, is one of major significance.

As the 'on-site' experimental programme was not specifically designed to investigate the characteristics of 'mobile' toilet/tissue-paper solid 'form', there are several questions, pertaining to the precise nature of the phenomenon, which can only be answered through rational consideration of the balance of available evidence. For instance, the question remains as to whether the transformation (of a toilet/tissue-paper solid), leading to improved efficiency of waste solid transport (over and above that predicted by Wakelin's (1978) equation for gradient), is a gradual one, or a near instantaneous one. It is only logical that, in normal straight pipe deceleration, solid 'length' will increase continuously, with distance travelled, as the 'concertina' format of the toilet/tissue-paper solid is gradually unfolded (and until complete extension of the 'concertina' has been achieved). However, it is less clear that 'thickness' expansion is also a continuous process. Although the previous analysis of descriptive data might seem to have suggested this to be the case, it must not be forgotten that values of 'thickness' will have increased with both compaction and expansion, and that, with initial 'length' expansion, and the simultaneous removal of 'concertina' form, values of solid 'thickness' would have appeared to decrease (were there no simultaneous 'thickness' expansion). Re-consideration of the reduction in gradient at the female 'branch-line' installation can assist in clarification of this question.

In-line with theoretical analysis of the effects of bends and junctions, as outlined in Section 10.3.2.6, it might have been expected that, with reduction in gradient and due to the consequent reduction in the amount of energy lost in negotiation of the 135° junction, the efficiency of 'branch-line' waste solid transport would be somewhat improved (relative to performance predicted, by Wakelin's (1978) equation for gradient, on the basis of transport at the steeper gradient). However, it can be seen, from Figures 10/108 and 10/109, that no such improvement occurred. In fact, as energy loss, at a bend or junction, is believed to be in proportion to the square of velocity at the bend or junction, it is possible to estimate the proportional reduction in 'loss of energy', occurring in consequence of the reduction of 'branch-line' gradient, simply by estimating the proportional reduction in the square of velocity at the junction. Taking rough estimates as to the values of 'C1', 'C2' and 'C3' (associated with female 'branch-line' 'non-faecal flush' 'trailing solid' deceleration), as 1.556, 0.027 and 57.63 respectively (see Figure 10/108), and given that the junction was positioned 1.428 metres from the female 'branch-line' W.C. (W.C.2.), while the gradients on this short 'leg' of pipework, between the W.C. and junction, transpired to have been 1:58 and 1:62, when the main length of discharge pipework was at gradients 1:150 and 1:200 respectively (see Section 10.3.2.6), it is suggested that the loss of energy at the 135° junction, and at the flatter gradient, would have been fully 98.7% of that at the steeper gradient.

Such a minute difference in the amount of 'energy loss' at the junction, between these two tests conducted at different gradients, could not possibly have led to any detectable divergence from an inter-relationship, between the two resulting deceleration characteristics, of the type predicted by Wakelin's (1978) equation. No single detail of system geometry, apart from gradient, was at variance between these two tests, and the inter-relationship displayed, between the two resulting deceleration characteristics, did in fact prove to be in precise agreement with the prediction of Wakelin's (1978) equation. In other words, the resulting velocity profiles display absolutely no indication that the phenomenon, of 'mobile' toilet/tissue-paper solid 'form', played any part in determination of 'branch-line' performance, and this, despite the fact that mean 'length' increased, by 12.9%, with reduction in gradient.

Thus, it can be seen, that 'length' expansion can occur without simultaneous 'thickness' expansion, and that, when this happens, no improvement in the efficiency of waste solid transport results. It can only be concluded; firstly, that the transformation leading to improved efficiency of waste solid transport is not that of 'length' expansion (removal of 'concertina' form); secondly, that 'thickness' expansion is not a continuous process; thirdly, that the transformation leading to improvement in the efficiency of waste solid transport is not a continuous one. Were it the case, that the transformation, achieved through the 'mobility' of toilet/tissue-paper solid 'form' (and to which, improvement in the efficiency of waste solid transport, over and above that predicted by Wakelin's equation, is attributable), was both gradual and continuous, then, even allowing that negotiation of the 135° junction might have severely dampened the phenomenon, it would have been expected that, given the scale of improvement displayed at the 'main-line' installation with reduction of gradient, at the very least, a minor improvement in efficiency would have occurred with similar reduction in gradient at the 'branch-line' installation. As this proved not to have been the case, it would seem that such transformation is neither gradual nor continuous, but rather, that a point is reached where the prevailing hydraulic forces have been so reduced as to allow the occurrence of a fundamental and almost instantaneous alteration in solid 'form'.

There would seem to be one obvious explanation as to the manner in which such a 'transformation' could occur. It is but logical to assume that each toilet/tissue-paper solid was possessed of a 'laminar' structure, the various layers of paper having been compressed, to all intents and purposes, into a single solid, by means of the action of W.C. discharge. Thus, it is possible that a point is arrived at, in subsequent deceleration, where for some reason the cohesive contact between individual layers is suddenly broken, and where, in consequence of this, thin layers of water are allowed to penetrate the solid between layers of paper. Such water penetration would greatly increase flotation, and could be considered synonymous to a step reduction in the 'saturated bulk specific

gravity' of the 'total' solid. As it can only be assumed that these layers would exist in the horizontal plane, it would seem only logical that, subsequent to water penetration, there would appear to have been a 'step' increase in the 'thickness' of each such solid. This would fall into line with the previous finding that, concurrent with increase in the efficiency of waste solid transport (over and above that predicted by Wakelin's equation), considerable increase in toilet/tissue-paper solid 'thickness' was observed. Furthermore, such disjuncture could only occur if the solid concerned was in an extended form, as, while in a 'concertina' mould, the different layers of paper would be firmly held together. But, as already discussed, toilet/tissue-paper solids arrive in the discharge pipework in a somewhat compressed 'concertina' form, and it is only with distance from the input device, and consequent reduction in the general level of prevailing hydraulic forces, that such solids undergo 'length' expansion (removal of the 'concertina' format). This would account for the fact that, while considerable 'length' expansion occurred, with reduction in 'branch-line' gradient, no improvement in the efficiency of waste solid transport ensued, the amount of length expansion simply having been less than sufficient to completely remove the 'concertina' format.

As to the causal parameters of 'transformation', it is logical that it is the natural flotation of each individual component layer of the toilet/tissue-paper solid which effects the sudden disjuncture. From this it follows; firstly, that an essential prerequisite to 'transformation' must be that there is a certain minimum depth of water surrounding the solid; and secondly, that, given such minimum depth of surrounding water, transformation will not occur only so long as the solid is held in a 'concertina' 'form'. The requirement, for a certain minimum depth of surrounding water, provides the clue as to why 'transformation' did not occur at gradient 1:150, at the female 'main-line' installation, as it did at gradient 1:200. After all, it is clear that, at gradient 1:200, the 'transformation' occurred at no great distance from the input device (as improved transportation is displayed over almost the complete length of each relevant velocity profile), and as the general level of prevailing hydraulic forces, at this distance and gradient, must have been higher than that, at say

twice this distance from the input device, at gradient 1:150, it would have been expected that similar 'transformation' would have occurred at gradient 1:150, but at a point further removed from the input device. However, it can now be concluded that no such transformation occurred, at gradient 1:150, since, at that point from the input device where the prevailing hydraulic forces had been so reduced as to allow complete solid extension (removal of 'concertina' form), the depth of water was less than sufficient to effect solid disjuncture.

From this 'model', of the manner and means of solid disjuncture (step reduction in 'saturated bulk specific gravity'), it can only be concluded; firstly, that the described 'transformation' could only occur at gradients flatter than 1:150 (with the possible exceptions, of an installation of even less complicated 'system geometry' than the straight discharge pipe female 'main-line' installation, and of an installation, similar in 'system geometry' to the female 'main-line', with which larger than average discharge volumes were employed); and secondly, that, at gradients flatter than 1:150, negotiation of any bend, junction, or other detail of system geometry which might serve to compact solids, must certainly delay 'transformation', and may, according to situation, dispel any possibility of 'transformation'. Thus, it would seem that, for all 'practical' installations, Wakelin's equation for gradient may indeed be considered truly valid, and on this basis, a design method may usefully be constructed from the mean 'live-waste' 'trailing solid' velocity profiles achieved at gradient 1:150.

However, although it may be difficult in practice to avoid the use of bends and junctions (and thereby ensure 'transformation' at flat gradients), it may well be that, possibly by use of some particularly simple connection between W.C. pan and main length of discharge pipe-work, installations could be designed to ensure the occurrence of 'transformation' in close proximity to the input device, after which it may be that, even given more complicated subsequent 'system geometry', or variations in gradient, the advantage of 'transformation' may be held. Thus, a laboratory based study, designed to fully investigate this unusual aspect of toilet/tissue-paper solid transportation,

might well disclose some practical advantage to be gained from intelligent use of the phenomenon of 'transformation' within the context of a design method.

10.3.3.4 Comparative Performance of Male and Female Waste Loads.

As discussed in Section 10.2.2.4, initial scrutiny of all available solid descriptive data seemed to suggest that, irrespective of facility, the average 'faecal' flush contained a greater quantity of toilet/tissue-paper material than did the average 'non-faecal' flush, while less strongly suggesting that the average male 'non-faecal' flush contained a greater quantity of such material than did the comparable average female flush, and even less strongly suggesting that the average male 'faecal' flush contained a greater quantity of such material than did the comparable average female flush. However, in this assessment of descriptive data, no account was taken of the particular pipe-route traversed by each individual waste load, which parameter was shown, in Section 10.3.3.3, to have had considerable effect upon toilet/tissue-paper solid 'form'.

The solid descriptive data compiled for each 'sample' of successfully monitored 'single' flushes (which encountered no previous deposits in the discharge pipework), as associated with each of the twelve different test combinations of flush type, pipe-route and gradient, and as summarised in Figure 10/110, would seem at least to confirm the first of these initial findings. For any one combination of gradient and pipe-route (and therefore facility), direct comparison between 'faecal flush' and 'non-faecal flush' waste loads, in respect of toilet/tissue-paper solid 'form', must eliminate the parameter of 'mobile form'. Even so, considerable disparity is displayed between the results of individual such comparisons, and in light of the fact, identified in Section 10.3.3.3, that small 'sample' waste loads were far less 'representative' than large 'sample' waste loads, this could only have been expected. A summary of these comparisons is presented in Figure 10/111.

It can be seen, from Figure 10/111, that the most 'representative' comparison (with respect to the number of flushes per 'sample'), for each of the male and female facilities, displays very close agreement with the average

such result calculated over all six different, but similar, comparisons. Thus, the toilet/tissue-paper component, of both male and female 'faecal flush' waste loads, is suggested to be approximately 21% 'longer', and 1.0%-1.5% 'thicker', than that of the associated 'non-faecal flush' waste loads. These differences can only be taken to represent increased amounts of such material in 'faecal flush' waste loads. However, these results merely suggest, that the proportional difference in the amount of such material per average flush, between 'faecal flush' and 'non-faecal flush' waste loads, was very much of the same order at both of the male and female facilities, but do not rule out the possibility that the average male waste load, of either particular flush type, contained a greater quantity of toilet/tissue-paper material than did the comparable average female waste load.

As discussed in Section 10.2.2.4, although descriptive solid data appears to intimate a very small difference between male and female waste loads in the amount of faecal material contained in the average 'faecal flush', statistical analysis suggested that this result is not significant. Similarly, although descriptive solid data appears to intimate a small difference between male and female waste loads in the average amount of toilet/tissue-paper material contained by either particular type of flush ('faecal' or 'non-faecal'), the available such data is less than sufficient to allow definite determination of this point. Minor differences in 'system geometry', as outlined in Section 10.3.2, existed between otherwise comparable male and female installations, and the observation point (for collection of descriptive solid data), was much further removed from the relevant input device, at the female facility, than was the case at the male facility. Thus, 'mobility' of toilet/tissue-paper solid 'form' could not be eliminated from any comparison between male and female 'samples' of descriptive toilet/tissue-paper solid data. In view of the fact, discussed in Section 10.3.3.3, that such 'mobility of form' is a far more complicated phenomenon than was appreciated at the time of initial descriptive solid data analysis (Section 10.2.2.4), any attempt to overcome this problem, by the application of correction factors, could only be far from precise, particularly since average small 'sample' waste loads could not be considered as truly 'representative.'

Having thus far considered all available descriptive data relating to relative loading of male and female discharges, and having been unable to identify any definite variation from one to the other, it is only from consideration of the six different average 'sample' 'live-waste' 'trailing solid' velocity profiles, as calculated for each of the 'non-faecal' and 'faecal' types of flush (and as presented in Figures 10/108 and 10/109 respectively), that any possible difference might now be identified. However, as male facility discharges were only monitored at gradient 1:150, the two female 1:200 profiles, for each of the 'non-faecal' and 'faecal' types of flush, must be ignored for the purpose in hand, as must both of the male and female 'branch-line' 1:150 profiles, for each of the 'non-faecal' and 'faecal' types of flush, as it was concluded, in Section 10.3.2.6, that detectable difference in the performance of 'like' waste loads could be expected between these two installations, simply as a result of the differences in 'system geometry'. Nonetheless, it was also concluded, in Section 10.3.2.6, that in comparison of 'live' waste load velocity data, between the male and female 'main-line' installations, geometric differences between the installations could not be held responsible for any significant disparity between results.

It can be seen from Figures 10/108 and 10/109 that, although modulative performance about the basic deceleration characteristic varied according to installation (as could only have been expected), no significant difference can be detected, in the basic level of deceleration of either 'faecal flush' or 'non-faecal flush' waste loads, between the male and female 'main-line' installations. Thus, despite the suggestion raised in respect of both 'faecal' and 'non-faecal' waste material, by the relevant descriptive solid data, that male waste loads may, on average, have been marginally heavier than comparable female waste loads, it can only be concluded that any such difference, which may have existed, was of very little significance to waste load transport performance.

However, it must be borne in mind, during consideration of this comparative assessment of male and female waste loads, that the length of uninterrupted straight discharge pipework, at the male facility, was less than would have been desired to ensure accurate assessment of 'modulative' performance. As failure to appreciate modulative performance,

in any particular situation, could result in serious error in assessment of the associated deceleration characteristic, less confidence can be placed, in any assessment of the male facility results, than can be placed in similar assessment of female facility results (see Sections 9.4.3, 10.3.1.2, 10.3.2.1 and 10.3.3.1).

One further point, worthy of mention, can be drawn from the fact, mentioned earlier in this Section, that the increased quantity of toilet/tissue-paper material carried by the average 'faecal flush', as compared to that carried by the average 'non-faecal' flush, was manifested as a 21.0% greater 'length' of material (approximate), and as a 1.0%-1.5% greater 'thickness' of material. The greater part of the increase was obviously taken up in the direction of 'length', and in accordance with the findings of Section 6., it can only be concluded, that this will have effected far less reduction, in the efficiency of 'faecal flush' waste load transport, than would have been the case had any such increase been manifested as an increase in 'thickness'. It may further be concluded, that any variation which may exist between typical male and female waste loads, in respect of the average amount of toilet/tissue-paper material contained by any one particular type of flush, would also manifest itself as a variation in 'length', thus effecting the least possible variation in transport performance.

10.3.3.5 Relevance to the Design of Above Ground Drainage Systems.

The work reported in this thesis was specifically intended to achieve a better understanding of the operation of long 'horizontal' drainage runs, as are mainly to be found in hospitals, but as are also to be found in some other large multi-storey buildings. Such long 'horizontal' drainage runs are a result of the architectural decision, to situate sanitary appliances so as to best meet operational requirements, in the context of total building usage, rather than to situate such appliances, in 'columns' up the building, so as to most easily achieve trouble-free operation of the connecting service pipework. Nonetheless, the results of this work may be considered to apply equally well to any 'horizontal' above ground drainage system installed within the range of normally accepted gradient settings.

As outlined in Section 10.3.3.3, Wakelin's (1978) equation for gradient may be considered truly valid for all 'practical' installations, transporting 'live' waste loads, as well as for all 'model' solid transportation. However, this can only be the case within certain gradient limits, as the relationship must break down as gradient becomes either very steep or very flat. With gradual increase in gradient, a point must occur, beyond which, all solid and liquid waste flows accelerate, rather than decelerate, subsequent to W.C. discharge. As Wakelin's (1978) equation relates only to deceleration, it cannot apply at such steep gradients. Similarly, Wakelin's (1978) equation suggests that, as gradient tends to zero, length of 'zone 2' transportation also tends to zero, while, at the same time, it is obvious that waste solids would travel a finite distance even if pipework was installed absolutely 'horizontally'. Thus, it can only be concluded that, as gradient tends to zero, the relationship breaks down.

It is apparent, from the cumulative findings of both this and Wakelin's (1978) studies, that the equation applies within the gradient range of from 1:40 to 1:150, but it is quite possible that, at least in respect of 'model' solid transport, the relationship holds well beyond this range. Using single maternity pad 'model' solids, discharged, from an un-vented Armitage Shanks 'back-inlet' V1206 P-trap W.C. pan, into a straight length of U.P.V.C. pipework, Wakelin (1978) performed laboratory tests at a gradient of 1:500. For the particular arrangement of 'system geometry' employed, application of Wakelin's (1978) equation to the relevant data (as presented in Figure 10/88), suggests termination of the 'zone 2' flow condition at an approximate distance of 3.1 metres from the inlet to the discharge pipework. In fact, the average point of solid deposition was found to be 4.5 metres from the inlet to the discharge pipework, but as the velocity monitoring equipment employed was unable to function successfully over such a short distance, it was not possible to determine whether or not the last 1.4 metres of solid travel could be attributed to 'zone 3' flow conditions. As outlined in Section 10.3.1.4, the 'zone 3' flow condition is by no means a natural progression beyond the point of termination of 'zone 2' flow conditions. Nonetheless, given that the amount of water to the rear of any solid will be at a maximum in close proximity to the input device, which parameter is of prime importance

to the promotion of 'zone 3' flow conditions, and bearing in mind the significant 'blockage factor' of the maternity pad solid, it would not be unreasonable to assume that 'zone 3' flow conditions would have occurred in such a case as this.

However, despite the fact that Wakelin's (1978) equation is an approximation, in that it only applies within certain gradient limits, and irrespective of what the exact limiting values of gradient might be, it is significant that, outside this gradient range (both above and below), solid performance can only be more efficient than that suggested by Wakelin's (1978) equation. There can be no doubt that this is indeed the case for extremely flat gradients, and the study of solid transport in steep gradient discharge pipes, conducted by Swaffield and Marriott (1977), shows that this is also the 'trend' at the opposite extreme. Similarly, although it was shown in Section 10.3.3.3 that, in certain circumstances, mobility of toilet/tissue-paper solid 'form' can cause 'live' waste load performance to diverge from that predicted by Wakelin's (1978) equation, such divergence can only occur as an improvement in waste load transport efficiency. Thus, for both 'live' waste loads and sterile 'model' solids, transport performance, no matter what the gradient, can be no less efficient than that predicted by Wakelin's (1978) equation. The use of this equation, as the basis for a practical 'worst case' method of design for above ground drainage systems, would therefore seem perfectly acceptable.

It is only possible to formulate the basis for a design method, since a considerable body of essential research, with regard to the effects upon waste solid transport of particular details of 'system geometry', has yet to be conducted. A great deal of information is presented in Section 10.3.2, concerning the effects of such parameters as W.C. Design, W.C. Orientation, Vertical 'pipe-drop', Cistern/Flush-pipe geometry, W.C. Venting, and bends and junctions, but the majority of such information is largely qualitative, relating to the principles governing the manner of response displayed in any given situation, and although an essential background to productive future research, is less than sufficient to allow for the development of a comprehensive design method at this point in time.

The basic 'live-waste' design method, which can be presented, must therefore be related to a specific arrangement of 'system geometry', and may be employed, for either a male or a female facility, to calculate the maximum length of straight U.P.V.C. discharge pipework which can be guaranteed to operate successfully at any particular chosen gradient setting. However, a proviso to this statement must be, that accurate gradient adjustment is an essential prerequisite to successful system operation, as is a good standard of workmanship in construction of the total installation (construction of joints, etc). As the monitored length of uninterrupted straight U.P.V.C. discharge pipework, at the male facility, was less than sufficient to ensure accurate assessment of the predominant 'modulative' performance of waste loads, and as this could possibly result in serious error in assessment of associated deceleration characteristics (see Sections 9.4.3, 10.3.1.2, 10.3.2.1 and 10.3.3.1), the design method presented is based upon the female 'main-line' installation (incorporating W.C.3.), which installation has been fully described, with regard to each different aspect of 'system geometry', in the relevant previous Sections of this report.

As outlined in Section 10.2.3, the ability of a flush to transport its own waste load deteriorated with increase in the size of that load. Similarly, the efficiency of any flush, as regards the removal of deposits encountered, was found to be inversely related to the size of the original load. 'Water only' flushes were found to have been most efficient, and 'faecal' flushes least efficient, at removing deposits encountered. Thus, the proportional rate of occurrence, of the different types of flush, must be a prime consideration in any design method. Similarly, and also as outlined in Section 10.2.3, the occurrence of one stoppage increased the probability of there being a second stoppage, and therefore, it must be assumed, increased the probability of escalation to a blockage. Thus, any design method must be geared to the avoidance of solid deposition above an agreed 'safe' level.

Rather than deal with the proportion, of all individual solids, which would be required not to deposit within the length of any particular installation, it is much easier to deal with the proportion, of all

flushes, which would be required not to deposit any solid within the appropriate length of pipework. As to determination of the most reasonable value, for a recommended 'safe' level of deposition, the available information is less than sufficient to allow a truly scientific approach. The proportion of all flushes which deposited at least one solid, at the female facility at gradient 1:150, at the female facility at gradient 1:200, and at the male facility at gradient 1:150, can be seen (from Figures 10/41, 10/45 and 10/49 respectively) to have been 4.6%, 9.1% and 20.6% respectively. As all of these installations appeared to function successfully, throughout the course of 'on-site' investigations, it might be concluded that a level of 20.0% of flushes depositing one or more solids could be accepted as 'safe'. However, installations must be designed to cope with such an eventuality as several unusually heavy discharges per-chance occurring in succession, which eventuality, though rare, must none the less be certain. Also, as the limiting 'safe' value cannot be determined precisely and scientifically, at this point in time, it is essential that the chosen value fall into line with a 'worst-case' approach, and incorporate a considerable margin to allow for possible error. For the design method presented, a value of 5.0% was therefore adopted, as the proportion of all flushes which may deposit one or more solids within the length of any particular 'horizontal' installation. However, the method can easily be adjusted to incorporate any other particular value which future research might suggest to be more appropriate.

The first step, in formulation of a design method, was to adjust the limiting value, of 5.0% of all flushes allowed to deposit one or more solids, to allow for the number of 'water only' flushes which might be expected to occur. As outlined in Section 10.2.2.2, and as summarised in Figure 10/27, of the flushes occurring at a normal female facility, 32.7% would be expected to be 'water only', 58.3% would be expected to be 'non-faecal' and 9.0% would be expected to be 'faecal'. Thus, of all 'loaded' female flushes ('faecal' and 'non-faecal'), approximately 7.4% ($5.0 / (58.3 + 9.0)$), may be allowed to deposit one or more solids (in order to satisfy the requirement of only 5.0% of all flushes depositing one or more solids). As it was also suggested, in Section

10.2.2.2, that, in view of the lack of available information, a 'worst-case' approach must be taken, with regard to the likely proportional rate of occurrence of the different flush types, in respect of male facilities incorporating adequate and socially acceptable urinal provision, it can only be assumed that, at such a facility, 73.7% of all flushes would be 'faecal', while the total remainder, of 26.3%, would be 'non-faecal'. Thus, only 5.0%, of all 'loaded' flushes, may be allowed to deposit one or more solids at a male facility. In this way, the disproportionate rate of occurrence of 'water only' flushes, between male and female facilities, was incorporated into the overall design method.

Secondly, and for each of the male and female design methods, it was necessary to estimate the mean and standard deviation of velocity, for each velocity measurement point, as would have been expected had the proportional rate of occurrence, of 'faecal' and 'non-faecal' flushes, conformed to that which would be predicted for a normal such facility (and as previously outlined). It must not be forgotten, that the male design method, as well as the female design method, was to be based upon female facility data, it being assumed that, on average, male flushes, of any particular type, perform indentially to female flushes, the only difference between the two design methods being the predicted proportional rate of occurrence of the different flush types. It must also not be forgotten, that the assessment of any particular flush type, for average performance, was based upon only those flushes which were successfully monitored, and which did not encounter any previous deposits already in the pipework. Thus, the proportional rate of occurrence of the different flush types, as encompassed by this definition, did not equate to the overall such proportional rate which would be predicted for either of a male or female normal facility.

This combination of 'faecal' and 'non-faecal' flush data, in the correct proportions for each individual facility design, was achieved through application of the following equations to the results recorded at each particular velocity measurement point;

$$\bar{x}_p = (P_f \cdot \bar{x}_f) + (P_{nf} \cdot \bar{x}_{nf})$$

$$(SD_p)^2 = (P_f \cdot ((\bar{x}_f - \bar{x}_p)^2 + (SD_f)^2)) + (P_{nf} \cdot ((\bar{x}_{nf} - \bar{x}_p)^2 + (SD_{nf})^2))$$

where; \bar{x}_p = Predicted mean 'trailing solid' velocity.

\bar{x}_f = Mean 'faecal flush' 'trailing solid' velocity.

\bar{x}_{nf} = Mean 'non-faecal flush' 'trailing solid' velocity.

P_f = Proportion of 'loaded' flushes which would be expected to be 'faecal' (at the facility in question).

P_{nf} = Proportion of 'loaded' flushes which would be expected to be 'non-faecal' (at the facility in question).

SD_p = Predicted standard deviation of 'trailing solid' velocity.

SD_f = Standard deviation of 'faecal flush' 'trailing solid' velocity.

SD_{nf} = Standard deviation of 'non-faecal' flush' 'trailing solid' velocity.

In order to check the validity of this method of predicting standard deviation, the above equations were employed to calculate means and standard deviations of velocity for the case of 55 'faecal' flushes per 307 'non-faecal' flushes. As these were the exact numbers of such flushes successfully monitored at gradient 1:150 at the female 'main-line' installation (which did not encounter any previous deposits), the results could

be compared to those, produced by the computer program MASTER GREENWICH (see Section 8.7 and Appendix II), which were calculated from the combined base data of all such 'faecal' and 'non-faecal' flushes. The computer output gave results to four decimal places, and to this level of accuracy, results produced by the equations in question were identical.

Having, in this way, arrived at estimates, for each of the male and female design methods, of the mean and standard deviation of velocity, associated with each particular velocity measurement point, as would be expected for the correct proportional rate of occurrence of the different 'loaded' flush types, it was then necessary to calculate an estimate, for each facility design method, of that performance which would be exceeded by the required proportion of 'loaded' flushes (92.6% (100.0 - 7.4) in the case of the female design method, and 95.0% (100.0 - 5.0) in the case of the male design method). An initial attempt, to achieve this end, employed the following equation;

$$V_d = \bar{x}_p - (K.SD_p)$$

where;

V_d = Design velocity (exceeded by the required proportion of 'loaded' flush 'trailing solids'), ($m.s^{-1}$).

\bar{x}_p = Predicted mean 'trailing solid' velocity, ($m.s^{-1}$).

SD_p = Predicted standard deviation of 'trailing solid' velocity ($m.s^{-1}$).

K = 1.445 (when ' V_d ' is to be exceeded by 92.6% of all 'trailing solids', i.e. female facility), or 1.645 (when ' V_d ' is to be exceeded by 95.0% of all 'trailing solids', i.e. male facility).

In calculation of the particular values of 'K' presented, it was assumed that, irrespective of distance travelled, velocities were 'normally' distributed about the relevant mean. However, it can be seen from

Figure 10/112, which illustrates the velocity distribution, at each velocity measurement point, of a sample of 'non-faecal flush' 'trailing solids', that although the 'non-faecal flush' velocity distribution initially closely approximated to a 'normal' distribution, it gradually became more and more 'skewed' (toward zero velocity), with distance travelled. Similarly, it can be seen from Figure 10/113, which illustrates the velocity distribution, at each velocity measurement point, of a sample of 'faecal flush' 'trailing solids', that 'faecal flush' velocity distribution also 'skewed' with distance travelled. As the performance specified, for each design method, had to be that which was exceeded throughout, and not just in the vicinity of the input device, by the required proportion of 'trailing solids', it was therefore necessary to calculate new values of 'K' (as associated with 92.6% and 95.0% respectively), which would better define the unusual velocity distributions displayed by live waste 'trailing solids'.

A numerical illustration, of the divergence from 'normal' of 'trailing solid' velocity distributions with distance travelled, is presented in Figure 10/114. It can be seen, not only that distributions became more 'skewed' with distance travelled, but also that, at any particular point, the distribution, of 'faecal flush' 'trailing solid' velocities, varied considerably from that of 'non-faecal flush' 'trailing solid' velocities. It can only be concluded, from this, that 'faecal flush' and 'non-faecal flush' sample distributions must be separately defined.

It is further apparent, from Figure 10/114, that, at any particular point, the distribution, of the sample containing both 'faecal' and 'non-faecal' flushes, can be estimated from consideration of the separate distributions, of the 'faecal flush' sample and of the 'non-faecal flush' sample, provided that the proportional make up of the combined sample is known (ratio of 'faecal' to 'non-faecal' flushes). For instance, at velocity point 6 (Figure 10/114), 12.7% of the 55 'faecal flush' 'trailing solids' fell below the nominal 95.0% design velocity ($K = 1.645$), while the comparative value for the associated 307 'non-faecal flush' 'trailing solids' was 6.5%, thereby suggesting the comparative value for the combined sample, of 55 'faecal' and 307 'non-faecal' flushes, to be;

$$\frac{(55.0 \times 12.7) + (307.0 \times 6.5)}{(55.0 + 307.0)} = 7.4\%$$

In fact, 7.2% of 'combined' sample 'trailing solids' fell below the nominal design velocity at this point. Some such estimates proved more accurate than the one presented, and some less accurate, but by and large, the method consistently gave results of approximately the correct order. It was therefore evident that, in calculation of 'K' values for any such 'combined' sample, the appropriate values of 'K', for the individual flush type samples, had to be 'weighted' according to the proportional make up of the combined sample.

For each individual sample of flushes, whether 'faecal' or 'non-faecal', that value of 'K' whose associated values of ' V_d ' were exceeded throughout by exactly 95.0% of 'trailing solids', hereinafter referred to as 'K1', was determined from scrutiny of the base velocity data. Similarly, for each sample, that value of 'K' whose associated values of ' V_d ' were exceeded throughout by exactly 92.6% of 'trailing solids', hereinafter referred to as 'K2', was also determined. These values, of 'K1' and 'K2', are presented in Figure 10/115. It can be seen, that the values obtained bear no obvious relationship to such factors as facility, gradient or installation, but that the type of flush concerned was equally obviously a relevant parameter. However, some question remained as to whether values of 'K1' and 'K2', arrived at from small sample data, were less 'representative' than similar large sample values. To test this possibility, and also to test the belief that, for 'combined' samples, values of 'K1' and 'K2' should be 'weighted' according to the ratio of constituent flush types, four different methods of calculating 'combined' sample values, of 'K1' and 'K2', were formulated:

- A. Taking simple mean values of 'K1' and 'K2' (hereinafter referred to as 'K1(A)' and 'K2(A)' respectively), from the data, presented in Figure 10/115, relating to the twelve basic independent flush samples (six off 'faecal' samples, and six off 'non-faecal' samples), thereby taking no account

of either sample size or flush type. The values arrived at in this way were;

$$K1(A) = 2.764 \qquad K2(A) = 2.136$$

B. Taking mean values, of 'K1' and 'K2', which were 'weighted' according to the size of each individual contributory sample (hereinafter referred to as 'K1(B)' and 'K2(B)' respectively), from the data, presented in Figure 10/115, relating to the twelve basic independent flush samples. Thus, account was taken of sample size, but no account was taken of flush type. The values arrived at in this way were;

$$K1(B) = 2.574 \qquad K2(B) = 1.923$$

C. Taking simple mean values, of 'K1' and 'K2', for each of the two different types of 'loaded' flush (hereinafter referred to as 'K1(C)f' and 'K2(C)f' respectively, for the 'faecal flush' sample group, and 'K1(C)nf' and 'K2(C)nf' respectively, for the 'non-faecal flush' sample group), from the data, presented in Figure 10/115, relating to each of the two different flush type sample groups. Thus, no account was taken of sample size, but the values arrived at allowed that account could be taken, in calculation of 'K1' and 'K2' for any particular 'combined' sample, of the ratio of 'faecal' to 'non-faecal' constituent flushes;

$$K1(C) = \frac{(K1(C)_f \cdot N_f) + (K1(C)_{nf} \cdot N_{nf})}{N_f + N_{nf}}$$

- where;
- K1(C) = An estimate of 'K1' for a particular 'combined' sample.
 - N_f = The number of 'faecal' flushes in the particular combined sample.
 - N_{nf} = The number of 'non-faecal' flushes in the particular combined sample.

An estimate of 'K2' for any particular 'combined' sample, 'K2(C)', being similarly calculated. The values arrived at, for use in this way, were;

$$K1(C)_f = 2.838 \quad K2(C)_f = 2.279$$

$$K1(C)_{nf} = 2.690 \quad K2(C)_{nf} = 1.992$$

D. Taking mean values of 'K1' and 'K2', for each of the two different types of 'loaded' flush, which were 'weighted' according to the size of each individual contributory sample (hereinafter referred to as 'K1(D)_f' and 'K2(D)_f' respectively, for the 'faecal flush' sample group, and 'K1(D)_{nf}' and 'K2(D)_{nf}' respectively, for the 'non-faecal flush' sample group), from the data, presented in Figure 10/115, relating to each of the two different flush type sample groups. In this way, account was taken, in calculation of values of 'K1(D)_f', 'K2(D)_f', 'K1(D)_{nf}' and 'K2(D)_{nf}', of relative sample size, and these values allowed that account could be taken, in calculation of 'K1(D)' and 'K2(D)' for any particular 'combined' sample, of the ratio of 'faecal' to 'non-faecal' constituent flushes, by similar calculation to that outlined for 'K1(C)' and 'K2(C)'. The values arrived at, for use in this way, were;

$$K1(D)_f = 2.885 \quad K2(D)_f = 2.256$$

$$K1(D)_{nf} = 2.487 \quad K2(D)_{nf} = 1.829$$

The design performance levels, associated with each different pair of estimates for 'K1' and 'K2', were then calculated for each of the six different 'combined' samples of 'faecal' and 'non-faecal' flushes (see Figure 10/115). For each combination, of design level estimate and sample, the proportion, of all 'trailing solids', which exceeded the specified performance throughout, was determined from scrutiny of the base velocity data. The results, of this assessment of 'combined' sample velocity distribution, are presented in Figure 10/116. It is immediately

apparent, that the two methods, which assumed small sample distribution data to be less 'representative' than similar large sample data (methods (B) and (D)), were the least accurate estimators for 'K1' and 'K2'. Although the differences between the results of the remaining two methods were far less significant, the reduced levels of 'standard difference' (between the design level aimed, at and that achieved), of the results of method (C), were considered to suggest this as the best available estimator for 'K1' and 'K2'.

Since a 5.00% deposition level had been suggested for the male facility design method, which was to be based upon 73.7% of 'loaded' flushes being 'faecal' (and 26.3% being 'non-faecal'), and since a 7.4% depositon level had been suggested for the female facility design method, which was to be based upon 13.4% of 'loaded' flushes being 'faecal' (and 86.6% being 'non-faecal');

$$\begin{aligned} K(\text{Male}) &= K1(\text{C}) = \frac{(2.838 \times 73.67) + (2.690 \times 26.33)}{100} \\ &= \underline{2.799} \end{aligned}$$

$$\begin{aligned} K(\text{Female}) &= K2(\text{C}) = \frac{(2.279 \times 13.37) + (1.992 \times 86.63)}{100} \\ &= \underline{2.030} \end{aligned}$$

Thus, for each design method, the mean, standard deviation and distribution, of 'trailing solid' performance, as would be expected for the correct proportional rate of occurrence of the different 'loaded' flush types, could be estimated. A design performance level, exceeded by the required proportion of all 'trailing solids', could therefore be calculated for each type of facility (male or female).

A complete summation of all 'trailing solid' velocity data, as recorded for those 'single' flushes which encountered no previous deposits already in the monitored pipework, is presented in Figures 10/117, 10/118 and 10/119. For each of the male and female 'normal facility' design methods, Figure 10/120 presents details of predicted mean 'trailing solid'

velocity, predicted standard deviation of 'trailing solid' velocity, and suggested design velocity (estimated to be exceeded by the required proportion of 'loaded' flush 'trailing solids'), as calculated, from the basic female 'main-line' (1:150), 'trailing solid' velocity data, using the various equations discussed to this point.

The performance levels suggested by these data, as associated with each of the female facility and male facility design methods, are graphically presented in Figures 10/122 and 10/123 respectively. It can be seen that, although the predicted mean 'trailing solid' performance, for a 'normal' male facility, was only marginally less efficient than that predicted for a 'normal' female facility (and this, due to the greater proportion of 'loaded' flushes being 'faecal', as opposed to 'non-faecal', at a 'normal' male facility, which flushes, on average, display slightly the less efficient transport performance), the suggested design performance level, for a 'normal' male facility, was considerably less efficient than that for a 'normal' female facility. That this was the case, reflects three further parameters: firstly, the assumed absence of 'water only' flushes at a 'normal' male facility, being a facility having adequate and socially acceptable urinal provision (see Section 10.2.2.2); secondly, the greater standard deviation of performance displayed by 'faecal', as compared to 'non-faecal', flushes (see Figures 10/117, 10/118 and 10/119); thirdly, the rather more significantly 'skewed' distribution of 'faecal flush' velocities, as compared to that of 'non-faecal flush' velocities, about any particular relevant mean (see Figures 10/112 to 10/115 inclusive). It must not be forgotten that, as previously mentioned, both of these male and female recommended design performance levels were calculated on the assumption that, on average, male facility waste loads, of any particular 'flush type', perform identically to comparable female facility waste loads, and that it is on this basis that such significant divergence would be predicted, between 'normal' male and female facilities, in the overall efficiency of system performance.

A final check was made to yet again re-assess the correctness of the assumption that, on average, male and female waste loads, of any particular 'flush type', may be taken to be identical, by calculating a recommended

design performance level, for a 'normal' male facility, from the data collected at the male 'main-line' installation. A summation of the relevant basic 'trailing solid' velocity data is presented in Figure 10/119. Figure 10/121 presents associated details of predicted mean 'trailing solid' velocity, predicted standard deviation of 'trailing solid' velocity, and suggested design velocity (estimated to be exceeded by the required proportion of 'loaded' flush 'trailing solids'), and Figure 10/124 displays this information graphically. The predicted mean and design level deceleration characteristics, calculated, for a 'normal' male facility design, from the female 1:150 'main line' velocity data (as presented in Figure 10/123), are also presented, in Figure 10/124, for comparison.

It can be seen that the velocity data points, calculated from male waste load results, were of the order of size that might have been expected (from consideration of the deceleration characteristics estimated from female waste load velocity data), but that, were lines of 'best fit' to be drawn through these data points, somewhat steeper deceleration characteristics, than those estimated from female waste load data, would be suggested. Nonetheless, to infer that such lines of 'best fit' would be reasonable approximations to the associated true deceleration characteristics would be far from correct. It is beyond question, that the data points presented, for each of the mean and design level velocity profiles, represent but a small section of a profile which, overall, must display modulative velocity variations. As, in each case, the available data points represent less than one complete wavelength of each modulative performance, no determination can be made as to the precise deceleration characteristic central to that profile. Thus, it was again the case, that no definite difference could be detected, between male and female waste loads, in respect of waste load transport performance, and therefore in respect of flush content, although the possibility could not be ruled out, that some such minor difference may exist. It can only be re-stated that, had it been possible to connect a greater length of straight discharge pipework to the male facility appliances, this situation might well have been avoided. However, all indications are, that any such difference which may exist could only be a relatively minor factor in the determination of comparative 'normal' male facility system efficiency (as to that of a 'normal' female facility), piling to insignificance in

comparison to differences in respect of the proportional rate of occurrence of different flush types, and in respect of standard deviation and distribution of performance between flush types.

The 'straight pipe' 'live waste' design method, based upon the 'system geometry' of the female 'main-line' installation (in respect of 'W.C. design', 'vertical pipe-drop', etc.), can be reduced, from the design level deceleration characteristics presented in Figures 10/122 and 10/123, to simple equations;

1. Female Facility Design.

Since; $V = 1.870 - 0.0438 \sqrt{L/G}$,

then; Maximum Pipe Length = 1823(G).
(at specified gradient)

Minimum Gradient = (L)/1823
(for specified pipe length)

where; V = Design level 'trailing solid' velocity, (m.s.⁻¹).
L = Distance from input device (pipe length), (m).
G = Pipe Gradient (non-dimensional).

For example, if it is required that a straight length of 100 mm. I.D. discharge pipework travel 22.0 metres, to connect a female facility W.C. pan to a vertical stack, then;

Minimum Gradient Required = (L)/1823
= 22/1823
= 0.012068
= 1:83

2. Male Facility Design.

Similarly, since;

$V = 1.742 - 0.0521 \sqrt{L/G}$,

$$\begin{aligned} \text{then;} \quad & \text{Maximum Pipe Length} & = & \underline{1116(G)} \\ & \text{(at specified gradient)} & & \end{aligned}$$

$$\begin{aligned} & \text{Minimum Gradient} & = & \underline{(L)/1116} \\ & \text{(for specified pipe length)} & & \end{aligned}$$

where; 'V', 'L' and 'G', are as in '1.' above.

For example, if it is required that a straight length of 100 mm. I.D. discharge pipework travel 22.0 metres, to connect a male facility W.C. pan to a vertical stack, then;

$$\begin{aligned} \text{Minimum Gradient Required} & = (L)/1116 \\ & = 22/1116 \\ & = 0.019713 \\ & = \underline{1:51} \end{aligned}$$

It is obvious, from the design equations presented, that, at any particular specified gradient, the maximum length of straight discharge pipework, acceptable in connection with a male facility appliance, will always be 38.78% $((1823 - 1116)/1823) \cdot 100$, shorter than that maximum length which would be acceptable in connection with a female facility appliance. Similarly, for any particular specified straight pipe length, the value of minimum gradient, acceptable in connection with a male facility appliance, will always be 63.35% $((1823/1116) \cdot 100) - 100$, greater than that value of minimum gradient acceptable in connection with a female facility appliance.

11. CONCLUSIONS AND FURTHER WORK.

11. CONCLUSIONS AND FURTHER WORK.

A data bank of useful information was compiled, in respect of both facility usage patterns and system loading, which, given the current lack of such data, will be of use in future research into many other aspects of drainage/sanitation-service performance. The validity of the M/M/s queueing theory, as a method by which to estimate the standard of service availability provided by any particular sanitary appliance, or group of such appliances, was demonstrated. Facility usage data, in combination with the M/M/s queueing theory, was employed to assess the 'normality' of the 'on-site' facilities observed, thereby allowing that peculiarities of usage could be taken into account in assessment of the 'normality' of system loading data. This area of investigation also served to highlight the dependence of peculiarities of usage upon details of facility layout and design, and it can only be concluded, that much greater thought must be directed to facility design, particularly with regard to the social acceptability of facilities, if subsequent usage is to comply to drainage design criteria.

From analysis of solid deposition data, it was found, not only, that the ability of a flush to transport its own waste content deteriorated with increase in the size of the original load, but also, that the efficiency of a flush, as regards the removal of deposits encountered, was inversely related to the size of the original load. It could only be concluded from this, that the proportional rate of occurrence of the different flush types must be a prime consideration in any drainage design method. It was also to emerge, that the occurrence of one stoppage increased the probability of a further stoppage, and thus, it must be assumed, increased the probability of escalation to a blockage. The premise, that above ground drainage should be designed to avoid the occurrence of solid deposition (above an agreed safe level), was therefore confirmed.

Flow observations indicated that faecal solids tend to the fore in all mixed content 'faecal' flushes, and that waste solids, irrespective of material composition, do not normally bypass one another during transportation (no single such occurrence having been observed throughout the course of 'on-site' investigations).

Detailed analysis, of waste solid velocity data, suggested that previous opinion, in respect of the mechanism of solid transport, was both incomplete and partially misconceived. With regard to 'zone 2' deceleration (see Section 2.2.2), it was found that all solids displayed 'modulative' velocity variations, about the associated deceleration characteristic, in response to continuous momentum transfers to and from surrounding water. Such 'modulations', which were generally of considerable initial amplitude (although precise amplitude was variable, and dependent upon such solid parameters as mass and blockage factor), decayed with distance from the input device. Thus, it could only be concluded, that techniques which take no account of modulative performance, as previously employed in estimation of 'linear' deceleration characteristics (such as the method of 'least squares'), can no longer be considered appropriate for such a purpose, and that an appreciation of 'modulative' performance is an essential prerequisite to successful estimation of 'zone 2' deceleration characteristics.

Examination of performance, in close proximity to the input device, suggested that the flow region, formerly termed 'zone 1', was in no way determined by any forces other than those which predominate throughout 'zone 2' transportation, although, since 'modulative' velocity variations decayed with distance travelled, those displayed in the area formerly considered to be 'zone 1' were of somewhat greater amplitude than 'zone 2' modulations. That 'zone 1' was ever considered a distinct and separate flow condition can be attributed to the misconception, that solid performance can be classified solely from consideration of 'average' velocity profiles.

Appreciation of the continuous nature of solid transportation, over those areas formerly described as 'zone 1' and 'zone 2', allows logical consideration of the dominant causal parameters of the observed 'modulative' deceleration. It is suggested that, due jointly to the mode of W.C. discharge and to the combined effects of the vertical 'pipe-drop', a waste solid enters the discharge pipe with considerable momentum. From this point on, the 'stored' energy of the solid is gradually dispelled, as is that of the surrounding water, and the respective velocities are reduced in consequence. As 'static' forces delay this loss of energy,

the solid decelerates in proportion to $\sqrt{L/G}$. The point at which all 'stored' energy has been dispelled, and at which solid transportation becomes totally dependent upon 'static' forces, marks the end of that flow condition formerly described as 'zone 2'. However, due again to both the mode of W.C. discharge and the combined effects of the vertical 'pipe-drop', a substantial disparity is normally set up, in the initial length of horizontal discharge pipe, between the velocities of waste solid and surrounding water. Thus, from the outset of horizontal transportation, a 'push me-pull you' effect is set up between the solid and its surrounding water. Throughout the course of solid deceleration, consecutive momentum transfers occur, both to and from the surrounding water, which, of necessity, result in waste solid velocity fluctuations. These fluctuations are initially of considerable amplitude, as initial momentum transfers are extremely violent, but they remain, nonetheless, simple modulations about the 'linear' deceleration characteristic.

With regard to the causal parameters of the initial disparity, between the velocities of solid and surrounding water, there are several possibilities. From observations of W.C. discharge, it would seem that solids, particularly larger solids (or those discharged late in the flush), tend to be 'catapulted' from the W.C. at velocities above those of surrounding water flows. Also, in the vertical 'pipe-drop', solids tend to fall in the central airspace, as opposed to in the peripheral water stream, and therefore attain greater momentum than otherwise would have been the case. However, although recorded modulations indicate that, initially, solid velocity normally exceeded that of the surrounding water, the opposite situation was also observed (even in the case of apparently identical 'models'). It can only be concluded, that the initial disparity, although somewhat random, is largely dependent upon the particular combination of input geometry and solid type.

From examination of performance subsequent to the 'zone 2' regime, it was found that significant proportions, of each of the different types of solid observed, were deposited prior to the onset of 'zone 3' flow conditions. It is suggested, that 'zone 2' conditions terminate

at the point at which all stored energy has been dispelled, and at which solid transportation becomes totally dependent upon 'static' forces. However, these 'static' forces (hydrostatic pressure, weight component and positive shear forces), all of which are continuously applied, need not, of necessity, be sufficient to overcome the frictional resistance to motion. Thus, those factors, which affect the levels of either of the 'static' forces, become determinants in the possible promotion, and subsequent level, of 'zone 3' flow. In this respect, solid blockage factor, position within the flush and flush volume, can only be considered to be of major importance. That a significant proportion of toilet/tissue-paper solids were deposited, prior to the onset of 'zone 3' flow conditions, emphasizes the fundamental importance of the 'zone 2' flow condition to system design. Due to the normal positional advantage held by faecal solids, the possibility, that an even larger proportion of such solids may also have failed to progress beyond the 'zone 2' flow condition, is relatively less important.

Analysis of multi-solid flush velocity data clarified the situation in respect of interactive solid transport mechanisms. Such mechanisms can be viewed as an extension of the 'push me-pull you' momentum transfer phenomenon, as associated with the 'modulative' 'zone 2' deceleration displayed by lone solids interacting with surrounding water. In the multi-solid flush, a momentum transfer 'cycle' is set up, between each solid and each of its neighbours, by means of transference through the intervening water streams (as opposed to by means of direct contact). Thus, each solid displays 'modulative' deceleration, but the particular pattern of modulations', displayed by each, is inversely related, with respect to time (as opposed to distance travelled), to that of its neighbours. With regard to the amplitude of multi-solid flush velocity modulations, this was found to be variable and dependent upon relative values of solid mass and blockage factor (as well as upon absolute such values), and relative position within the flush was also found to be a relevant parameter. 'Modulative' decay was observed to be far less rapid than was the case for lone solid discharges.

Since it was found that appreciation of 'modulative' performance is an essential prerequisite to successful estimation of 'zone 2' deceleration,

it can only be concluded, that previous research works, which were based upon Wakelin's (1978) definition of the mechanism of solid transport, and which were concerned with the effects upon waste solid transport of various pipework and input device parameters, must of necessity have involved varying levels of misinterpretation of data. Wakelin's (1978) analysis of the effects of various bends and junctions has been shown to have been particularly subject to such misinterpretation of data. Thus, a considerable body of research must yet be conducted, in respect of such parameters as 'W.C. design', 'W.C. discharge geometry' and 'pipe fittings', in order to allow that installed drainage system solid transport measurements, as reported in this work, can be employed as the basis for a comprehensive empirical design method. In this respect, 'pipe diameter' must also be considered as a detail of system geometry which has yet to be investigated.

A most useful aspect of this work, in relation to the development of a comprehensive empirical design method, is that it allows that future research, in respect of the effects of various pipework and input device parameters, may be conducted in the laboratory environment, and yet may still be linked to 'live' waste load performance. It has been shown, that no particular manner of response, displayed by 'faecal flush' waste loads to any specific detail of system geometry, could be attributed, in any way, to the presence of faecal material. 'Live' waste load performance was totally dominated by the 'mode' of toilet/tissue-paper solid transport, faecal material serving merely as 'ballast', and thereby causing a simple reduction, in some proportion to the total mass of material, in overall levels of performance. Given that the mode of toilet/tissue-paper solid transport may be taken to be identical to that of the range of towel type sanitary protection products, this allows that specific towels may be selected, from consideration of the wide range of performance levels associated with such products, to 'model' the performance of specific 'live' waste loads in a sterile and controlled environment.

However, it has been shown that, in one respect only, the 'mode' of toilet/tissue-paper solid transport does vary from that of towel type sanitary protection products. It is suggested that, under certain circumstances, and as a result of the 'mobility of form' displayed by toilet/tissue-paper solids, a 'transformation' or 'disjuncture' of such

solids can occur, synonymous to a step reduction in saturated bulk specific gravity, which, of necessity, gives rise to a step increase in transport efficiency. The conditions, essential for the promotion of such solid 'disjuncture', were identified as complete extension of 'concertina' form (in the direction of length), and a certain minimum depth of surrounding water, which combination could generally only be achieved at gradients flatter than 1:150, and in close proximity to the input device (since wave attenuation rapidly dispels the required minimum depth of surrounding water), where the intrusion of pipe fittings was at an absolute minimum. It could therefore only be concluded that, for all practical installations, such solid 'disjuncture' could not normally occur. Thus, in future laboratory based research, the mode of toilet/tissue-paper solid transport may be taken to be identical to that of the range of towel type sanitary protection products. Nonetheless, further investigation might well disclose some practical advantage to be gained from intelligent use of the phenomenon, of toilet/tissue-paper solid 'disjuncture', within the context of a design method. Such investigation could best be conducted in a sterile and controlled environment.

Although Wakelin's (1978) equation for 'zone 2' deceleration can only apply within certain gradient limits, and must therefore break down as gradient becomes either very steep or very shallow, and although, in certain unusual circumstances, the phenomenon of toilet/tissue-paper solid 'disjuncture' can effect waste load transport, it can only be concluded that, since all such situations, which do not result in conformation to Wakelin's (1978) equation, can only give rise to an improvement in waste load transport efficiency, Wakelin's (1978) equation is an acceptable base from which to develop a practical 'worst case' method of design for above ground drainage systems. In line with this premise, specific 'live' waste load design performance levels have been presented, for a specific arrangement of 'system geometry' (pipework and input device parameters), and assuming specific estimated 'normal' proportional rates of occurrence of the different flush types ('faecal', 'non-faecal' and 'water only'), based upon the avoidance of solid deposition above a recommended 'safe' level. Such a limiting 'safe' level of solid de-

position could not be precisely and scientifically estimated from the available information, and the level recommended was therefore somewhat arbitrarily determined. However, the performance levels presented can be easily adjusted to incorporate any other particular 'safe' level of deposition which future research might suggest to be more appropriate.

With regard to the relative performance of specific types of male facility and female facility 'live' waste loads, all indications were, that any differences which may exist could only be relatively minor. It could only be concluded that, in the determination of comparative 'normal' male facility system efficiency (as to that of a 'normal' female facility), any such minor differences must pale to insignificance in comparison to differences in respect of the proportional rate of occurrence of the different flush types, and in respect of mean, standard deviation and distribution, of performance between flush types. However, it must be stressed that, in consequence of differences in respect of the proportional rates of occurrence of the different flush types (as estimated for 'normal' male and female facilities), the type of facility to be serviced must become a prime consideration in the design of connecting drainage pipework.

In final clarification of this work, it is intended that the 'live' waste load design performance levels, as presented, be employed, initially, as the basis for a future laboratory based 'calibration' approach to drainage research (in respect of further investigation of the effects upon waste solid transport of various pipework and input device parameters), and subsequently, as the basis for a comprehensive empirical drainage design method linked directly to installed drainage system solid transport measurements.

12. BIBLIOGRAPHY.

12. BIBLIOGRAPHY

- Albritton, E.C., (1953), "Standard Values in Nutrition and Metabolism." W.A.D.C. Technical Report, 52-301, Wright Air Development Centre Wright-Patterson Air Force Base, Ohio. December.
- Babbitt, H.E., (1924) "Tests on the Hydraulics and Pneumatics of House Plumbing". Engineering Expt. Station Bulletin No. 143, University of Illinois.
- Bockus, H.L., (1946), "Gastro-Enterology". Philadelphia, W.B. Saunders Company, Vol.3.
- Boerner, F and Sunderman, F.W., (1949), "Feces, Normal Values in Clinical Medicine". Chap 29, W.B. Saunders Co., Philadelphia, Pa.
- British Standards Institution, (1950), "Engineering and Utility Services". British Standard Code of Practice, C.P.3. Chap. VII.
- British Standards Institution, (1973), "Slab Urinals (Stainless Steel)". British Standard, B.S. 4880, Part 1.
- British Standards Institution, (1974), "Sanitary Appliances; Selection, Installation and Special Requirements". British Standard Code of Practice, C.P. 305, Part 1.
- British Standards Institution, (1977), "Vitreous China Bowl Urinals". British Standard, B.S. 5520.
- Building Regulations, (1972), "Sanitary Conveniences". Part P. (England and Wales), Req. No. P3(4).
- Burberry, P., and Griffiths, T.J., (1962), "Demand and Discharge Pipe Sizing for Sanitary Fittings". Architects' Journal Library, 21 Nov.
- Burberry, P., (1978) "Water Economy and the Hydraulic Design of Underground Drainage". Seminar on Drainage Design, Brunel University. May.
- Burgess, J.A., (1963), "Trichomonas Vaginalis, Infection from Splashing in Water Closets". British J. Vener. Dis., 39, pp(248-250).
- Cantarrow, A., and Shepartz, B., (1957), "Biochemistry", 2nd Edition, W.B. Saunders Co., Philadelphia, Pa., p275.

- Cooper, R.B., (1972), "Introduction to Queueing Theory". Macmillan, New York.
- Courtney, R.G., (1976), "A Multinomial Analysis of Water Demand". Building and Environment, 11(3).
- Cox, D.R., and Smith, W.L., (1961), "Queues". Methuen & Co. Ltd., London.
- Davidson, P.J., and Courtney, R.G., (1976), "Revised Scales for Sanitary Accommodation in Offices". B.R.E. Current Paper. April.
- Dawson, F.M., and Kalinske, A.A., (1937), "Hydraulics and Pneumatics of Plumbing Systems". University of Iowa, Engineering Studies Bulletin, No. 10.
- Dawson, F.M., and Kalinske, A.A., (1939), "Hydraulics and Pneumatics of Plumbing Drainage Systems". Tech. Bulletin Nat. Assoc. of Master Plumbers of U.S.Inc.
- Diem, K., (ed.), (1962), "Documenta Geigy Scientific Tables". 6th Edition. Geigy Pharmaceuticals, Ardsley, New York.
- Fantus, B., Wozasek, O., and Steigmann, F., (1941), Am. J. Digest. Dis., " 8:296.
- Feachem, R.J., (1979), Personal communication, November 1979; part of "Sanitation and Disease", proposed publication 1983, Feachem et.al.
- Feachem, R.J., Bradley, D.J., Garelick, H., Mara, D.D., (prop. publ. 1983), "Sanitation and Disease: Tough Aspects of Excreta and Waste Water Management". J. Wiley and Sons. Inc.
- Flenning, D.N., (1977) "Use of Public Washrooms in an Enclosed Suburban Shopping Plaza." National Research Council of Canada, D13R.714, March.
- Francis, J.R.D., (1956), "The Speed of Drifting Bodies in a Stream", J. of Fluid Mechanics, Vol. 1(5), pp 517-20, November.
- Galwin, L.S., (1979), "Review of HUD/NBS Residential Water Conservation Program". C.I.B. W62 Seminar, November.
- Galwin, L.S., Swaffield, J.A., and Bridge, S.A., (1982), "A Computational Method for Unsteady Partially Filled Pipe Flow and Finite Solid Velocity Transport". Paper for AIAA/ASME Joint Fluids, Plasma, Thermoplastics and Heat Conf., St. Louis, M.O., AIAA-80-0980, June.

- Garg, V.K., and Round, G.F., (1969/70), "Capsule Pipeline Flow - a Theoretical Study" Procs. I. Mech. E. Vol.184, pp 89-100.
- Goldblith, S.A., and Wick, E.L., (1961), "Analysis of Human Faecal Components and Study of Methods for their Recovery in Space Systems". A.S.D. TR 61-419. Aerospace Medical Laboratory, Wright Patterson Air Force Base, Ohio; August.
- Gradwohl, R.B.H, (1956), "Faeces. Clinical Laboratory Methods and Diagnosis". Chap VIII, C.V.Mosby Co., St Louis, Mo., Vol 2 p 1261.
- Greater London Council, Byelaws of., Regulation No 2(2).
- Greater London Council, Places of Public Entertainment Technical Regulations, (Publication No 71680378)
- Hawk, P.B., and Bergheim, O., (1927), "Practical Physiological Chemistry" Philadelphia, Blakiston Co., p.310.
- Hospital Building Notes, No.12. Outpatient Department.
No.18. Administration Department.
No.23. Childrens Ward.
All available from H.M.S.O.
- Howarth, G., Swaffield, J.A., and Wakelin, R.H.M., (1980), "Development of a Flushability Criterion for Sanitary Products." CIBW62 Seminar Brunel University, June 3 and 4.
- Hunter, R.B., (1924), "Minimum Requirements for Plumbing in Dwellings". Plumbing Code Committee Report, U.S. Dept., of Commerce.
- Hunter, R.B., Golden, G.E., and Eaton, H.E., (1938), "Cross Connections in Plumbing Systems". National Bureau of Standards Journal of Research.
- Hunter, R.B., (1940), "Methods of Estimating Loads in Plumbing." U.S. National Bureau of Standards.
- Ivy, A.C., (1945), "Brenneman's Practice of Pediatrics". Hagerstown, Md, W.F. Prior Co., Inc., Vol I.
- Kira, A., (1976), "The Bathroom". Penguin Books Ltd., pp 113-117.
- Knoblauch, H.J., (1980)., "Fakazell, a New Test Medium to Simulate Reality in W.C. System Performance Evaluation" CIBW62 Seminar, Brunel University, June 3 and 4.

- Marriott, B.S.T., (1979), "Transport of Solids with Reduced Flush Volumes." D.Re.G., Brunel University.
- Mendes, M., (1977), "Bricks in the Cistern, Bugs in the Bowl." New Scientist. 24 November.
- Pink, B.J., (1973), "A study of Water Flow in Vertical Stacks by Means of a Probe." B.R.E. Paper CP 36/73 and CIB W62 Symposium, Stockholm.
- Porter, J.R., (1950), "Bacterial Chemistry and Physiology." John Wiley and Sons, Inc., New York, N.Y., p. 352.
- Public Health Act, (1936), Section 89. Power to Require Sanitary Conveniences to be Provided at Inns, Refreshment Houses etc., (also includes places of public entertainment.)
- Public Health Act, (1961), Section 80. Gives meaning of "Refreshment House."
- Robinson, C.S., (1922), J.Biol.Chem., 52:455, 1922; 66:811, 1925.
- Swaffield, J.A., (1975), "A Study of the Transport of Waste Solids in Above Ground Sanitary Drainage Systems." The Public Health Engineer, No 17, Sept.
- Swaffield, J.A., (1980), "A Study of the Effect of Water Conservation on W.C. and Drainage System Performance." J. I.P.H.E. London.
- Swaffield, J.A., (1980), "Building Drainage System Research; Past Influences, Current Efforts and Future Objectives". Construction Papers, Vol. I., No. I., Institute of Building.
- Swaffield, J.A., (1981), "Dependence of Model Solid Transport in Drainage Systems on Solid Geometry, Mass and Pipe System Parameters." NBSIR, 81-2307, U.S Dept. of Commerce.
- Swaffield, J.A., and Bokor, S.D., (1978), "A Preliminary Investigation of the Requirements and Suitability of Solid Models as Substitutes for Excreta in the Study of Above Ground Hospital Drainage Systems." BT/D.Re.G/2., Brunel University.
- Swaffield, J.A., and Bokor, S.D., (1980), "Application of Laboratory Test Techniques to Building Drainage Design." CIB W62 meeting, Brunel University.

- Swaffield, J.A.,
Bridge, S., and Galwin,
L.S., (1980),
"Wave Attenuation in Long Drainage Pipes,
a Numerical Solution of the Unsteady
Partially Filled Pipe Flow Equations."
CIB W62 Meeting, Technische Fachhochschule,
Berlin.
- Swaffield, J.A.,
Bridge, S., and Galwin,
L.S., (1982),
"Unsteady Flow in Building Drainage Systems,
a Numerical Approach to the Prediction of
Wave Attenuation and Solid Transport."
(to be published). C.I.B. Building
Practices Journal.
- Swaffield, J.A., and
Marriott, B.S.T., (1977),
"Hospital Drainage Design; A Study of
Solid Transport in Steep Gradient Discharge
Pipes." D.Re.G., Brunel University.
- Swaffield, J.A., and
Marriott, B.S.T., (1978),
"An Investigation of the Effect of Reduced
Volume W.C. Flush on the Transport of
Solids in Above Ground Drainage Systems."
CIB W62 Meeting, Brussels.
- Swaffield, J.S., and
Wakelin, R.H.M., (1975),
"An Empirical Approach to the Design of
Above Ground Hospital Drainage Systems."
CIB W62 Meeting, Glasgow University.
- Swaffield, J.A., and
Wakelin, R.H.M., (1977),
"Observations and Analysis of the
Parameters Affecting the Transport of
Solids in Building Drainage Systems".
Journal IP.H.E., London; also CIB W62
Meeting, NBRI Oslo.
- Swaffield, J.A., and
Westaby, M., (1978),
"A Preliminary Study of the Operation of,
and Drainage Flow from, Disposable Bedpan
Macerators."
BT/D.Re.G./1, Brunel University.
- Tsukagoshi, N., and
Matsuo, Y., (1975),
"Performance Tests for the Carriage of
Excreta in the Drainage System Connected
to Water Saving Type Closets." CIB W62
Symposium, pp 4/1-4/15.
- Uujamhan, E.J.S., (1978),
"Effect of W.C. Discharge Geometry on the
Transport of Solids in Internal Drainage
Systems". M.Sc. Dissertation, BT/D.Re.G./3.,
Brunel University.
- Uujamhan, E.J.S., (1981),
"Water Conservation W.C. Design: A Study of
the Design Parameters Affecting W.C.
Performance." Ph.D. Thesis, Brunel
University. August.
- Wakelin, R.H.M., (1978),
"A Study of the Transport of Solids in
Hospital Above Ground Drainage Systems."
Ph.D. Thesis, Brunel University.

- Watson, C.J., (1936), Am. J. Clin. Path., 6:458, 1936;
Arch. Int. Med., 59:196, 1937
- Webster, C.J.D., (1972), "An Investigation of the Use of Water Outlets in Multi-storey Flats," Building Services Engineer, 39(1).
- Webster, C.J.D., and Lillywhite, M., (1979), "Investigations of Drain Blockages and their Implications on Design." Journal of I.P.H.E., July.
- Westaby, M., (1979), "The Transport of Solids in 'Live' Horizontal Waste-pipe and Drainage Systems." D.Re.G., Brunel University.
- White, A., Handler, P., Smith, E.L., and Stetten, D.Jnr., (1954), "Principles of Biochemistry". McGraw-Hill Book Co. Inc., New York, N.Y., p.514, p.398.
- Williams, E.J., Eakin, R.E., Beerstecher, E.Jnr., and Shive, W., (1950), "The Biochemistry of B Vitamins" A.C.S. Monograph 110, Reinhold Publishing Co., New York, N.Y., pp 366-368.
- Wise, A.F.E., (1952), "One Pipe Plumbing - Some Recent Experiments at the Building Research Station." Journal I.P.H.E., Vol. 51.
- Wise, A.F.E., (1979), "Water, Sanitary and Waste Services for Buildings." B.T. Batsford Ltd, London.
- Wise, A.F.E., and Croft, J., (1954), "Investigations of Single Stack Drainage for Multi-storey Flats." Journal Royal Sanitary Institute, Vol. 74, No. 9.
- Wozasek, O., and Steigmann, F., (1942), Am. Journal Digest. Dis. 9: 423-425.
- Wyly, R.S., (1964), "Investigation of the Hydraulics of Horizontal Drains in Plumbing Systems." U.S. National Bureau of Standards, Monograph 86, Washington.
- Wyly, R.S., and Eaton, H., (1961), "Capacity of Stacks in Sanitary Drainage Systems for Buildings." National Bureau of Standards Monograph. 31 July.

13. FIGURES.

Pressure-depth profile on solid deviates from hydrostatic.

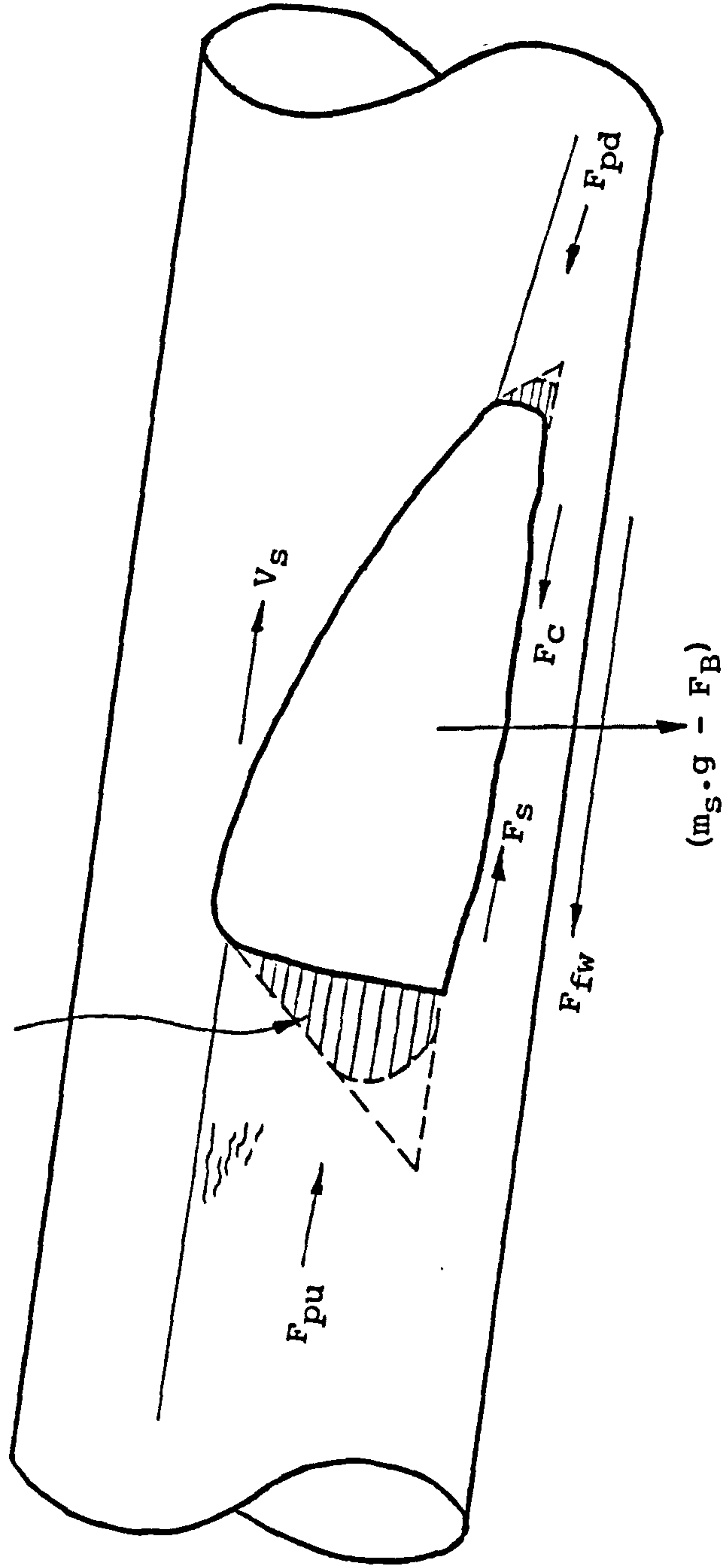
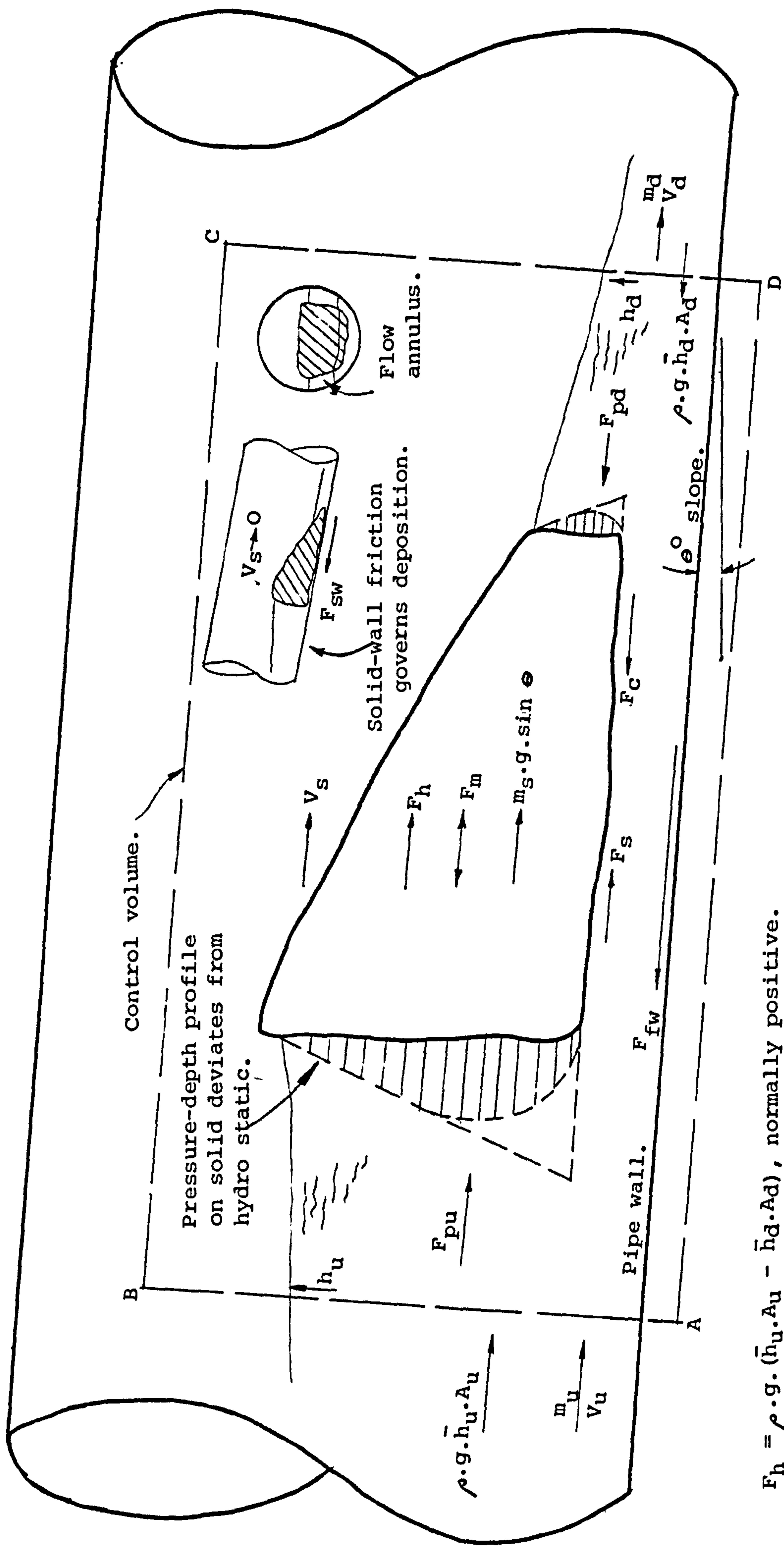

FIGURE 3/1. - Schematic Representation of the Forces Involved in Determining Solid Motion.



$F_h = \rho \cdot g \cdot (\bar{h}_u \cdot A_u - \bar{h}_d \cdot A_d)$, normally positive.

$F_m = m'_u \cdot (V_u - V_s) - m'_d \cdot (V_d - V_s)$, positive or negative depending on flow condition.

FIGURE 3/2. - Schematic Representation of the Forces Acting on the Solid and the Fluid Annulus Within a Control Volume ABCD.

F_{pu}, F_{pd} , Hydrostatic Forces = $\rho \cdot g \cdot \bar{h} \cdot A'$

F_B , Buoyancy Force based on wetted surface.

F_F , Sliding Frictional Force = $\alpha \cdot (m_s \cdot g - F_B) \cdot \cos \theta$.

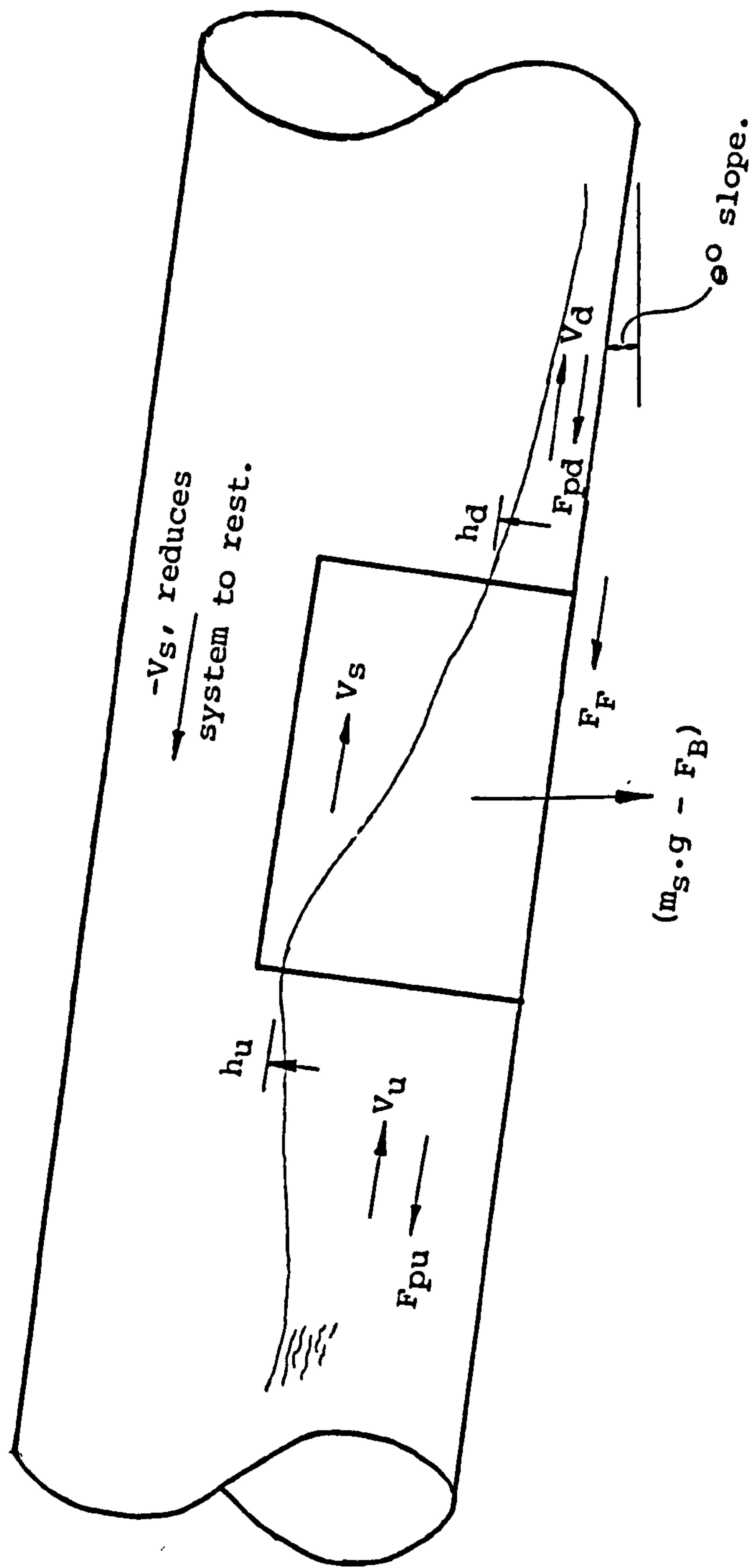

FIGURE 3/3. - Schematic Representation of the Forces Acting on the Solid, Where the Solid Itself Forms the Limits of the Control Volume.

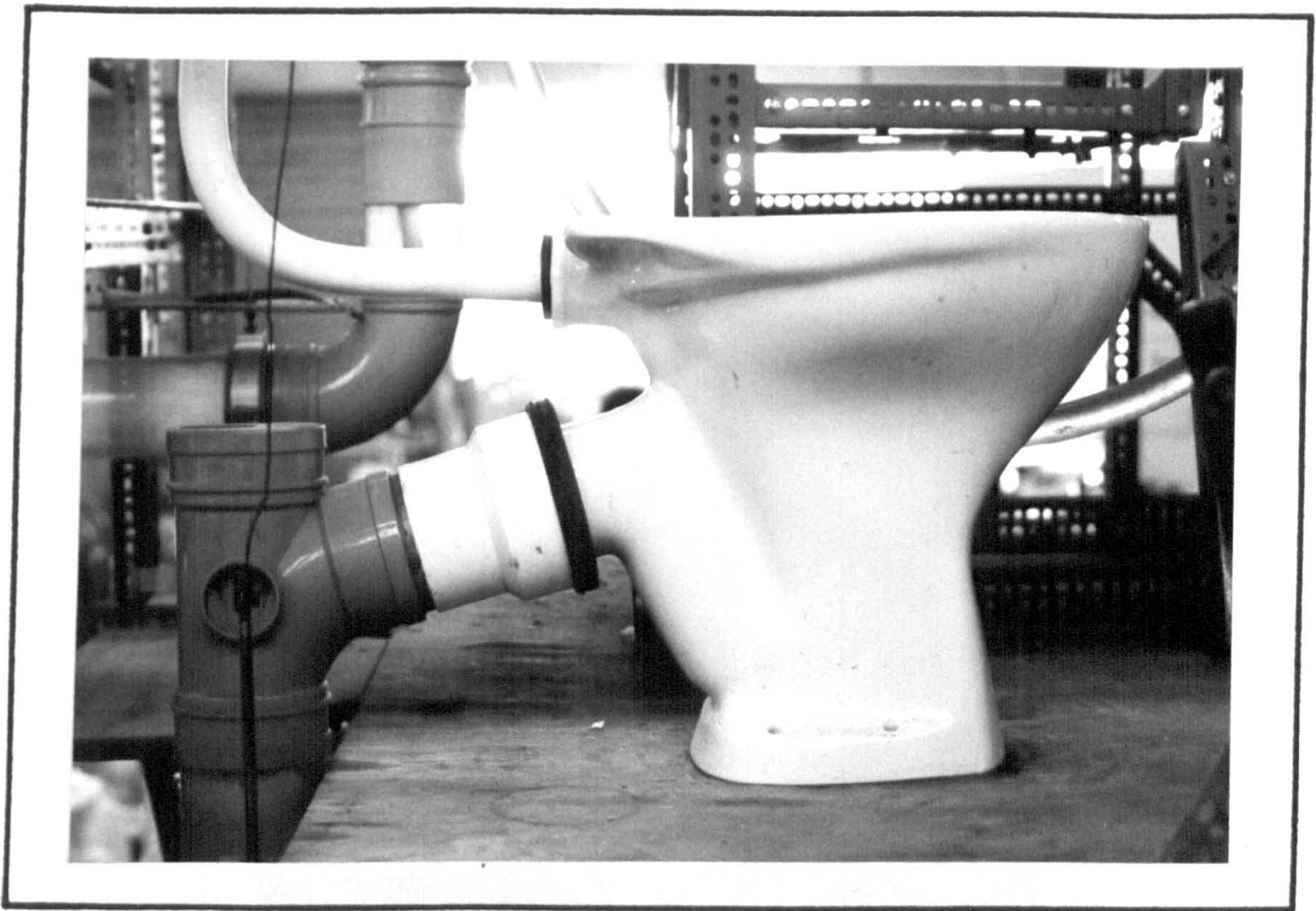

FIGURE 4/1. - Twyfords P-trap, 109° outlet 'back-inlet', W.C. pan, (B.S.1213).

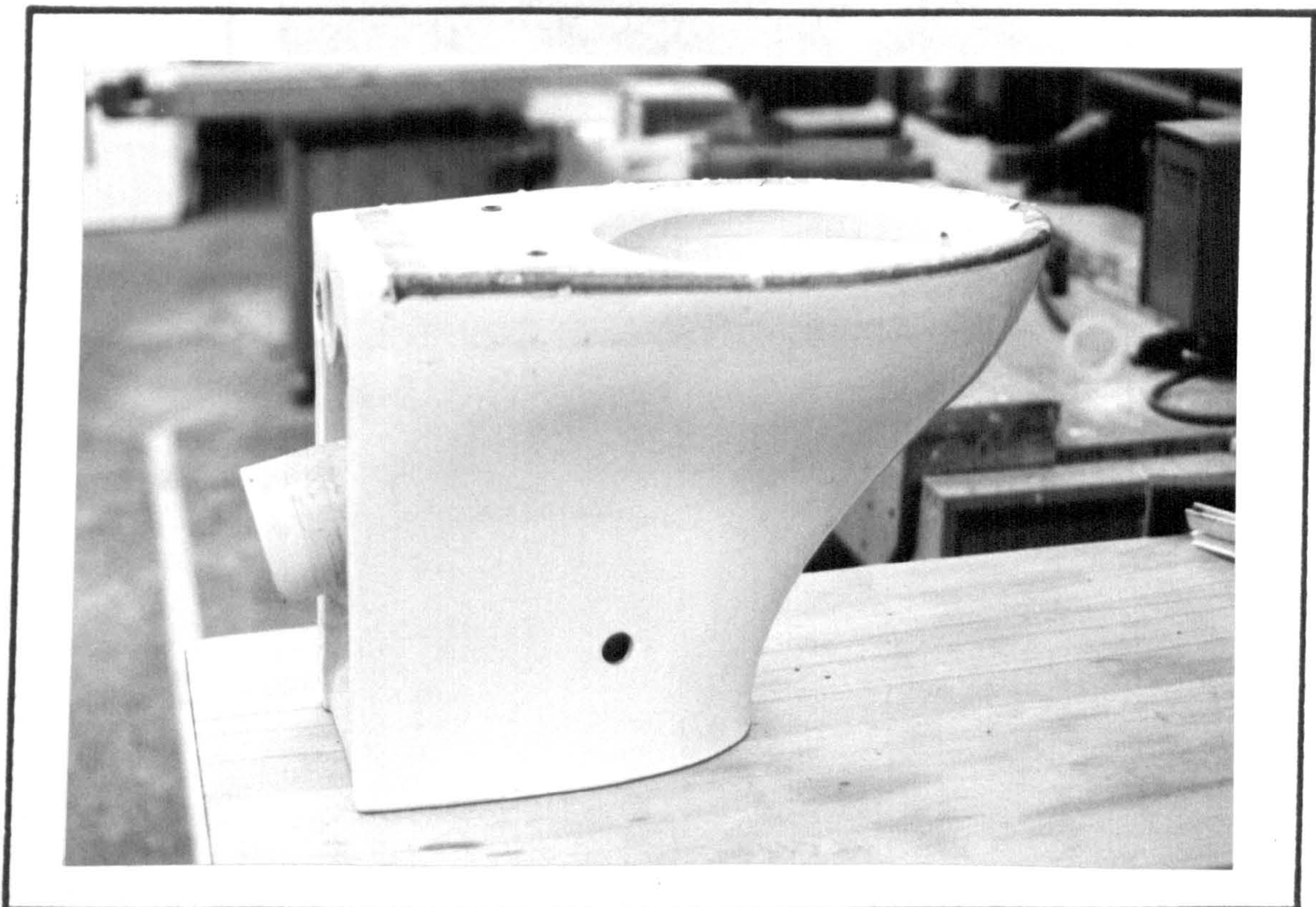

FIGURE 4/2. - Armitage Shanks, V1206 Contour, P-trap, 'back-inlet', W.C. pan, (B.S. 3402).

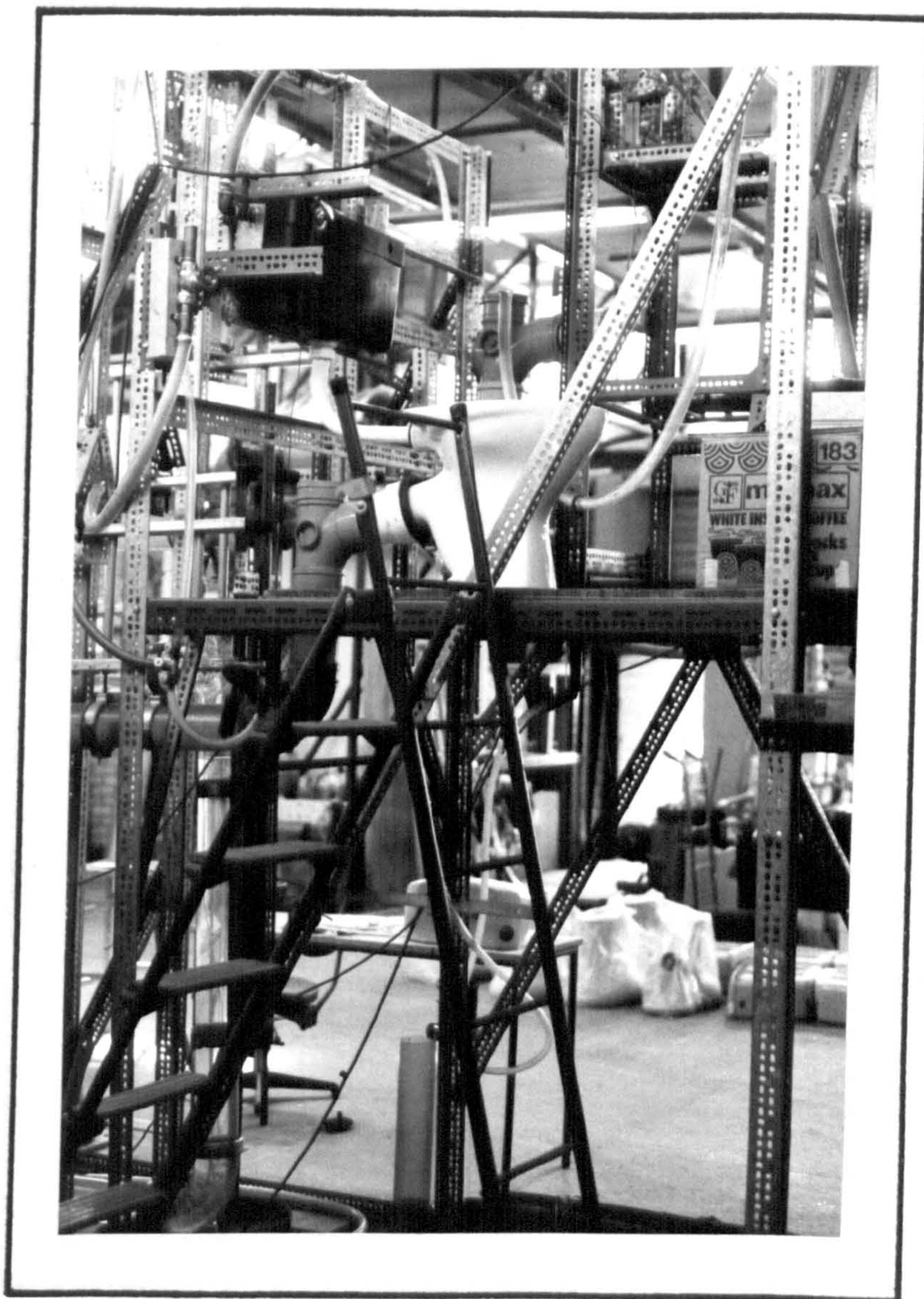

FIGURE 4/3. - W.C. Support Rig,
(Laboratory Study).

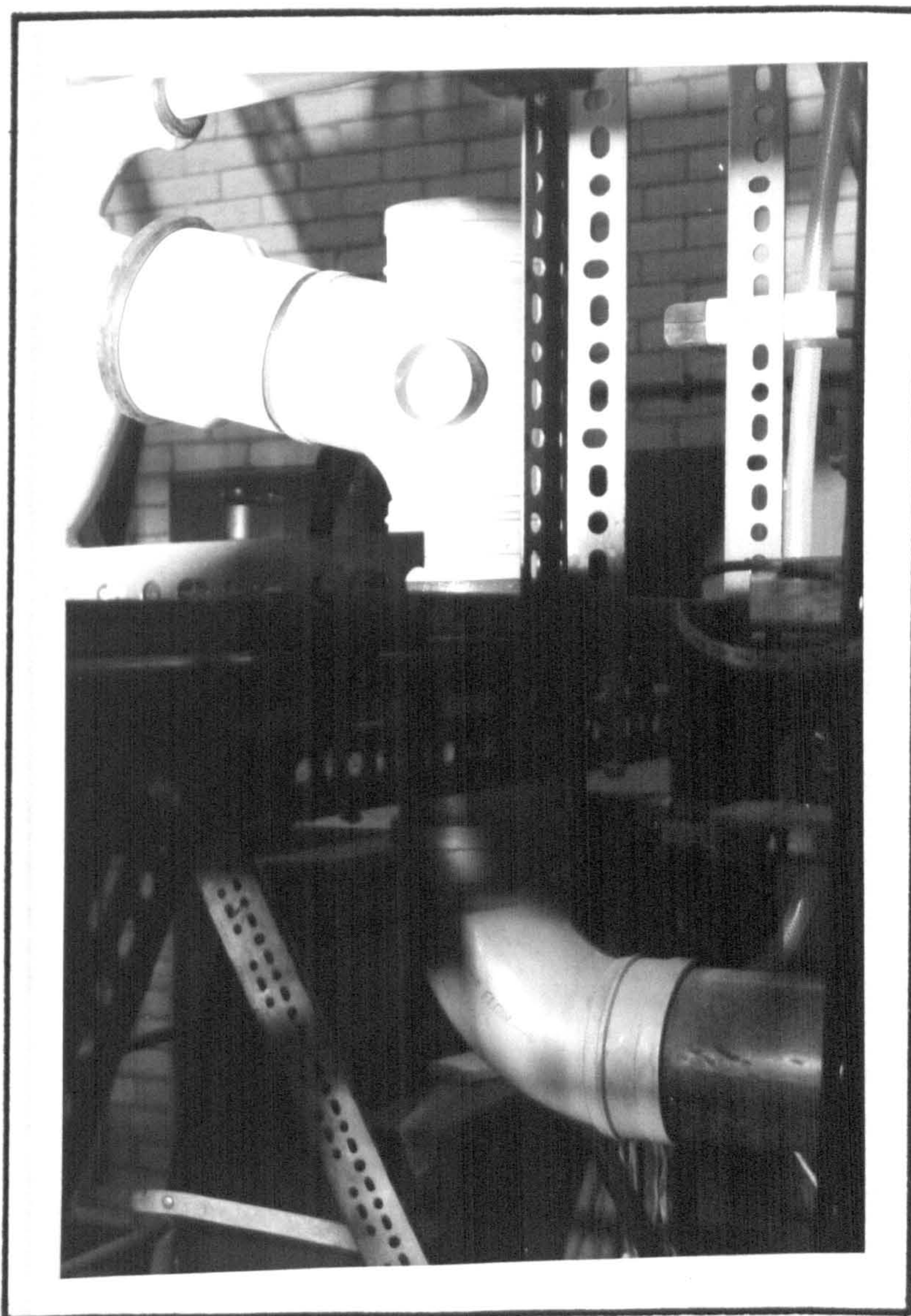

FIGURE 4/4. - Inlet to Discharge Pipe,
(Laboratory Study).

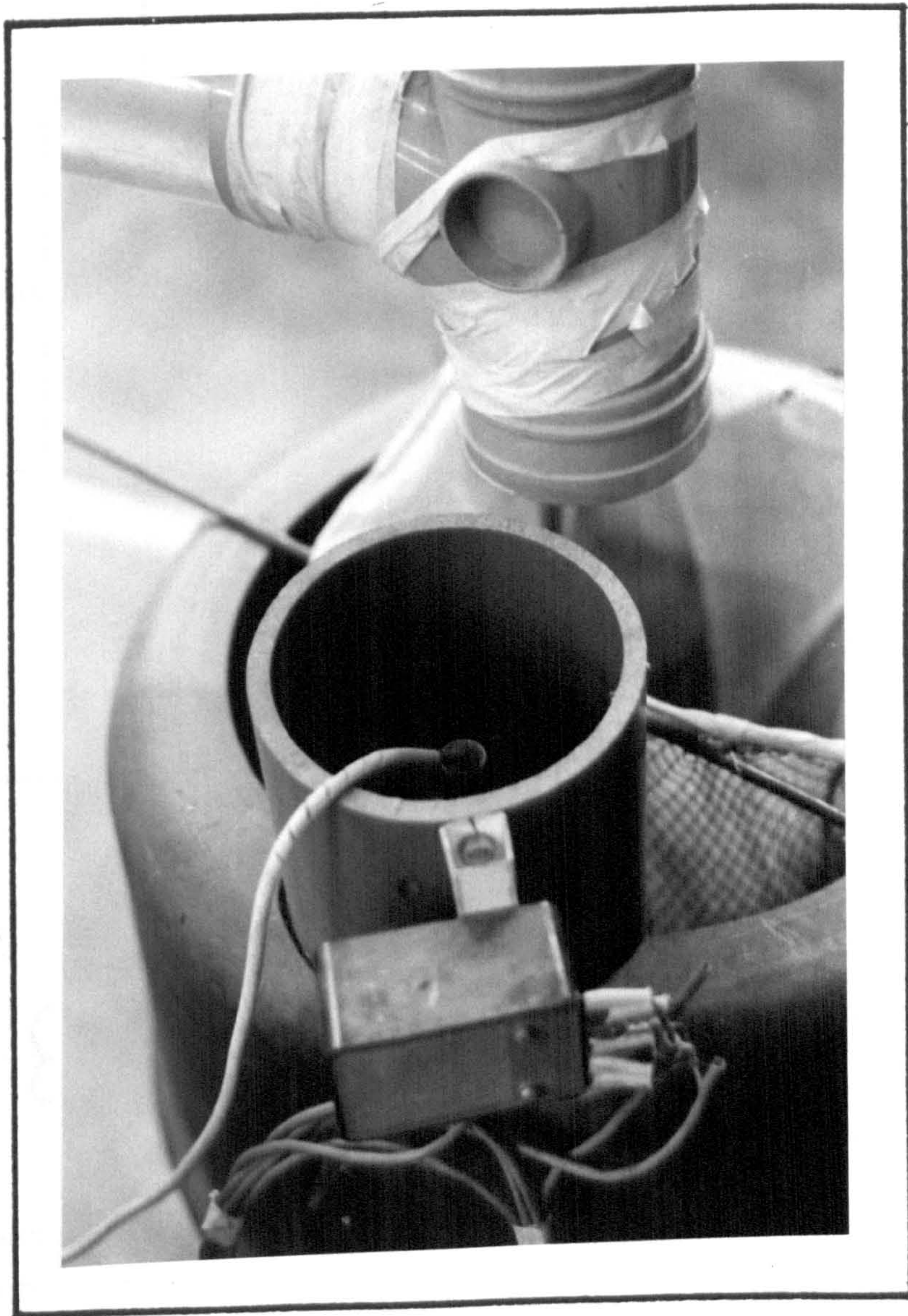

FIGURE 4/5. - Outlet from Discharge Pipe,
(Laboratory Study).

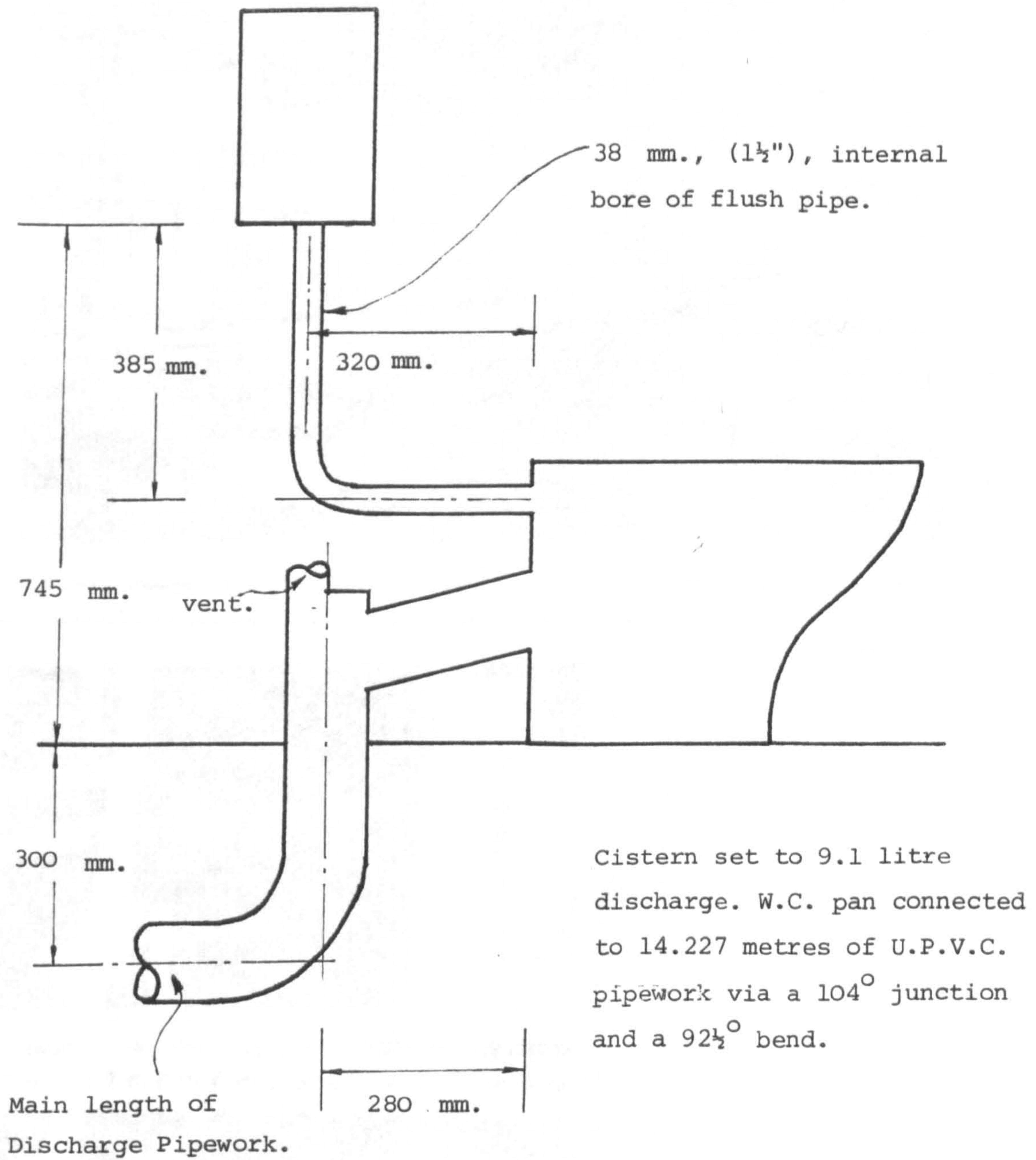

FIGURE 4/6. - W.C./Cistern Configuration, (Laboratory Study).

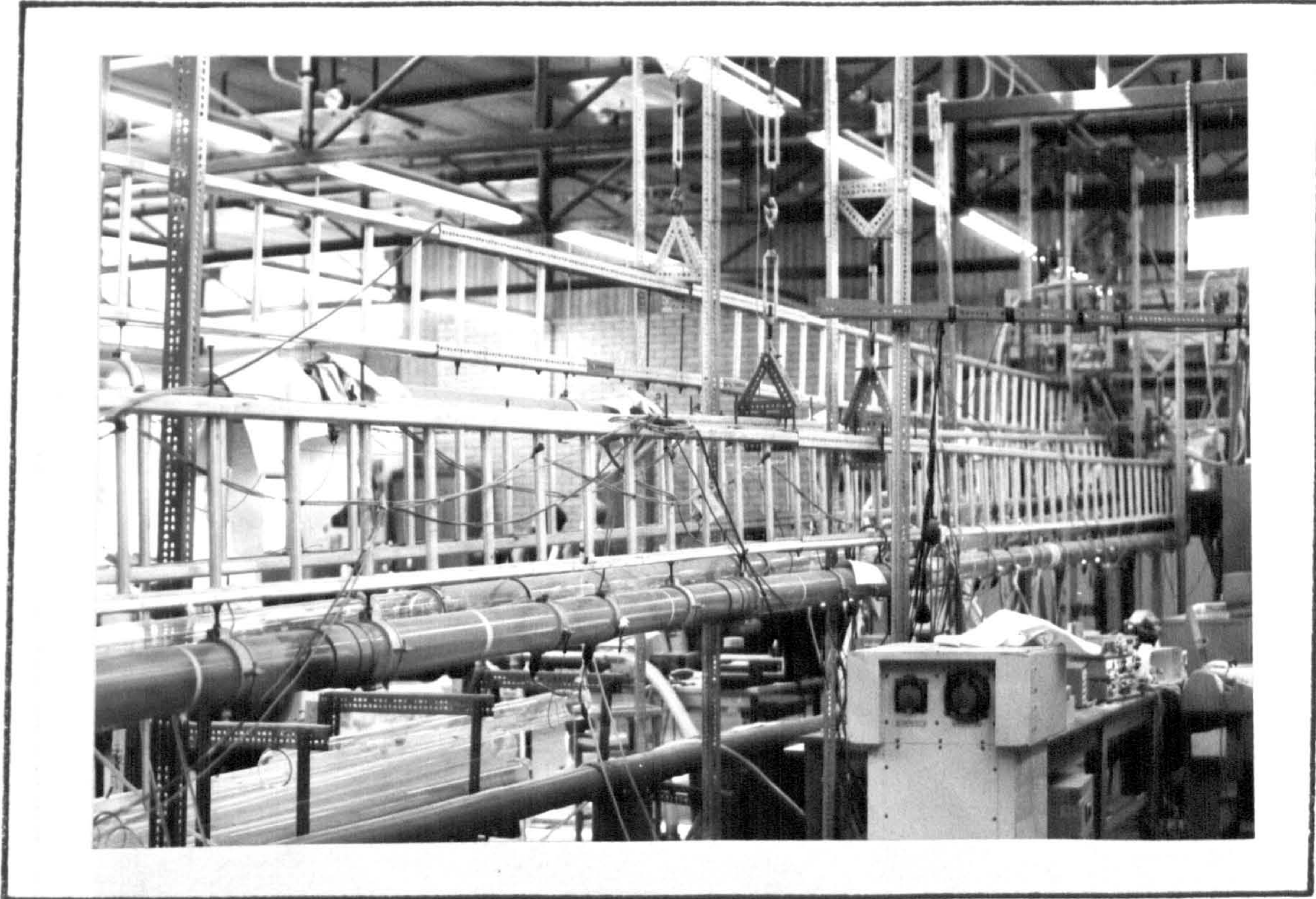

FIGURE 4/7.
Method of Pipe Support,
(Laboratory Study).

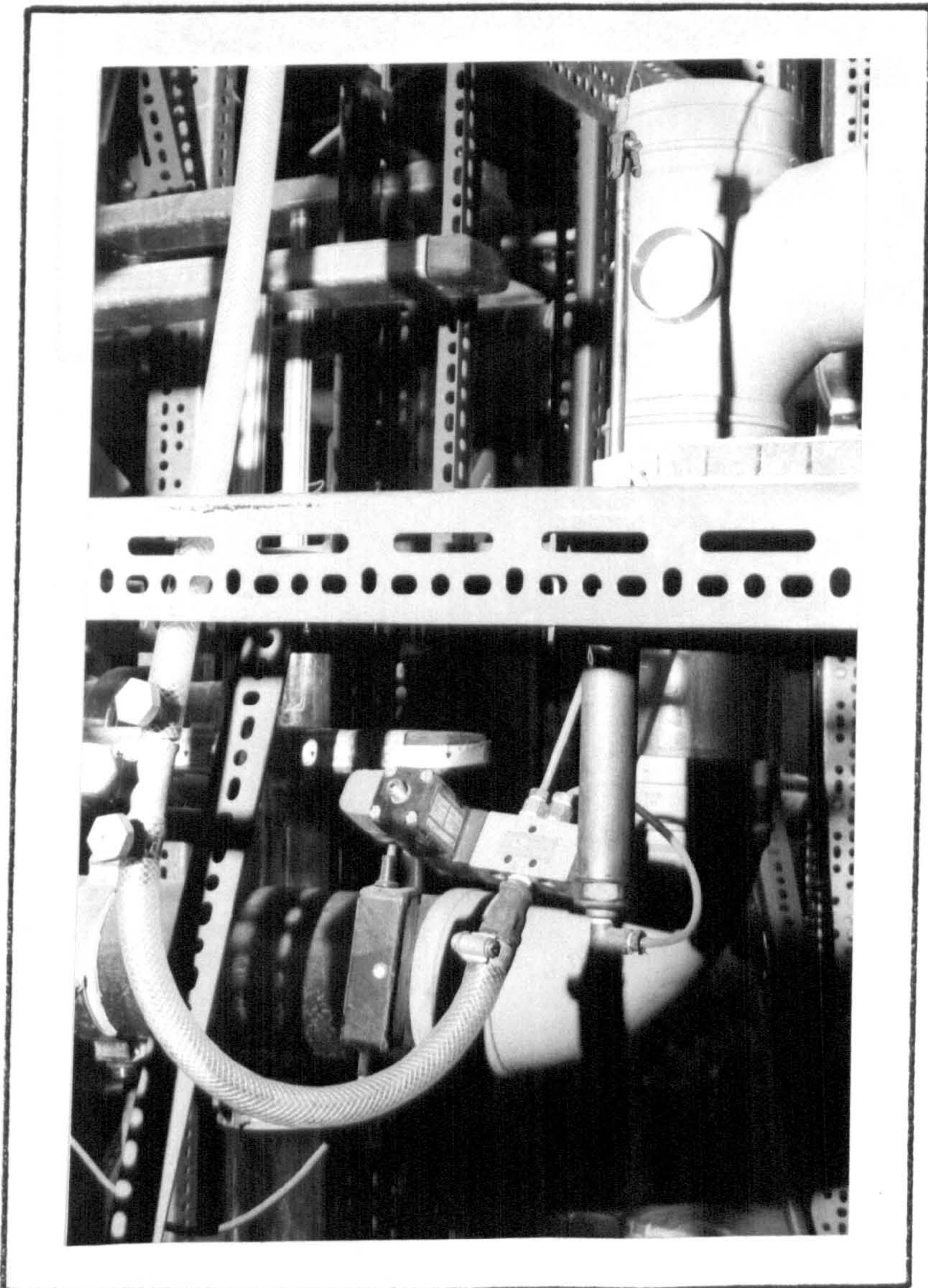

FIGURE 4/8.
Automatic Flushing
Mechanism,
(Laboratory Study).

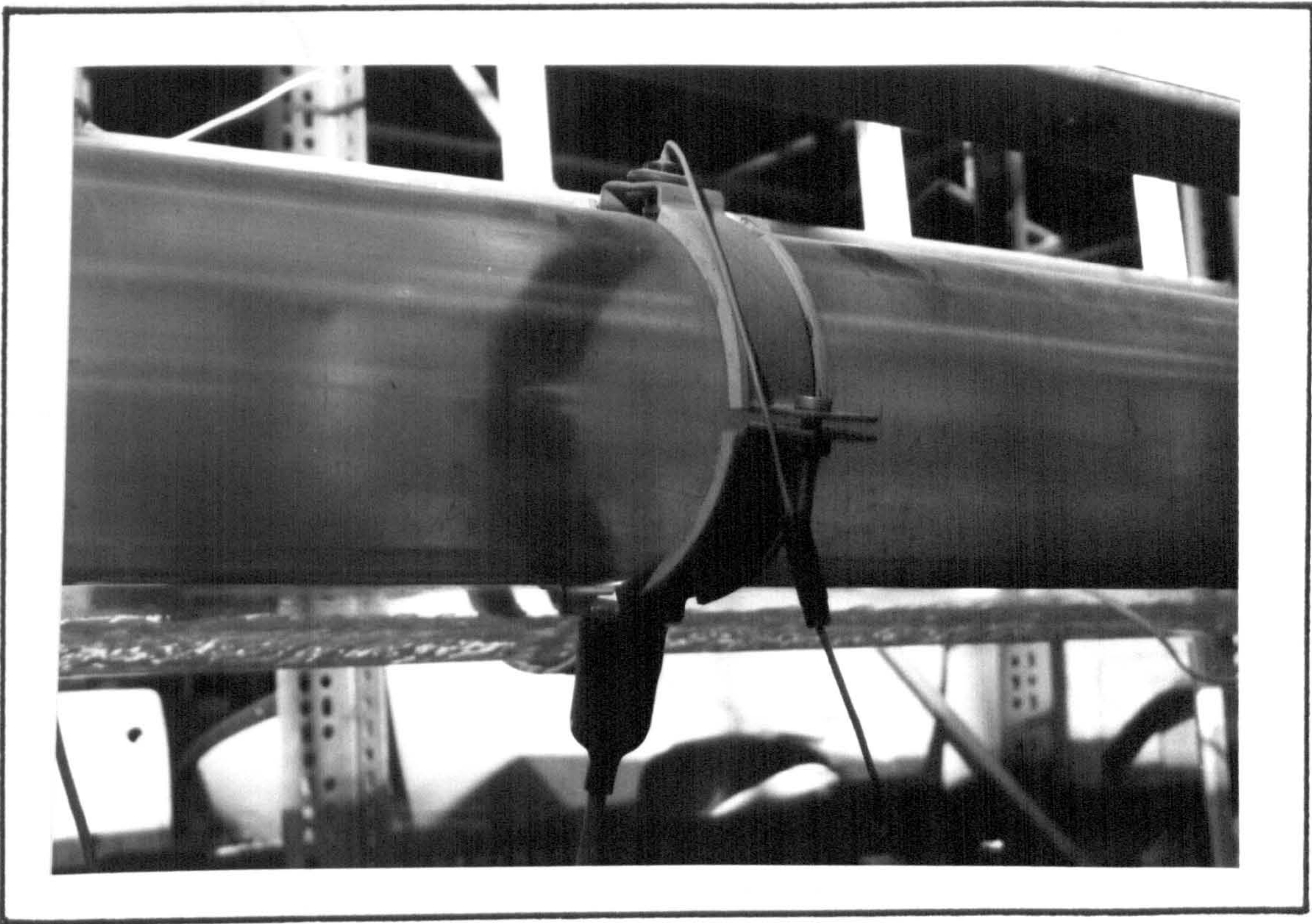

FIGURE 4/9. - Photo cell / Light-source Arrangement,
(Laboratory Study).

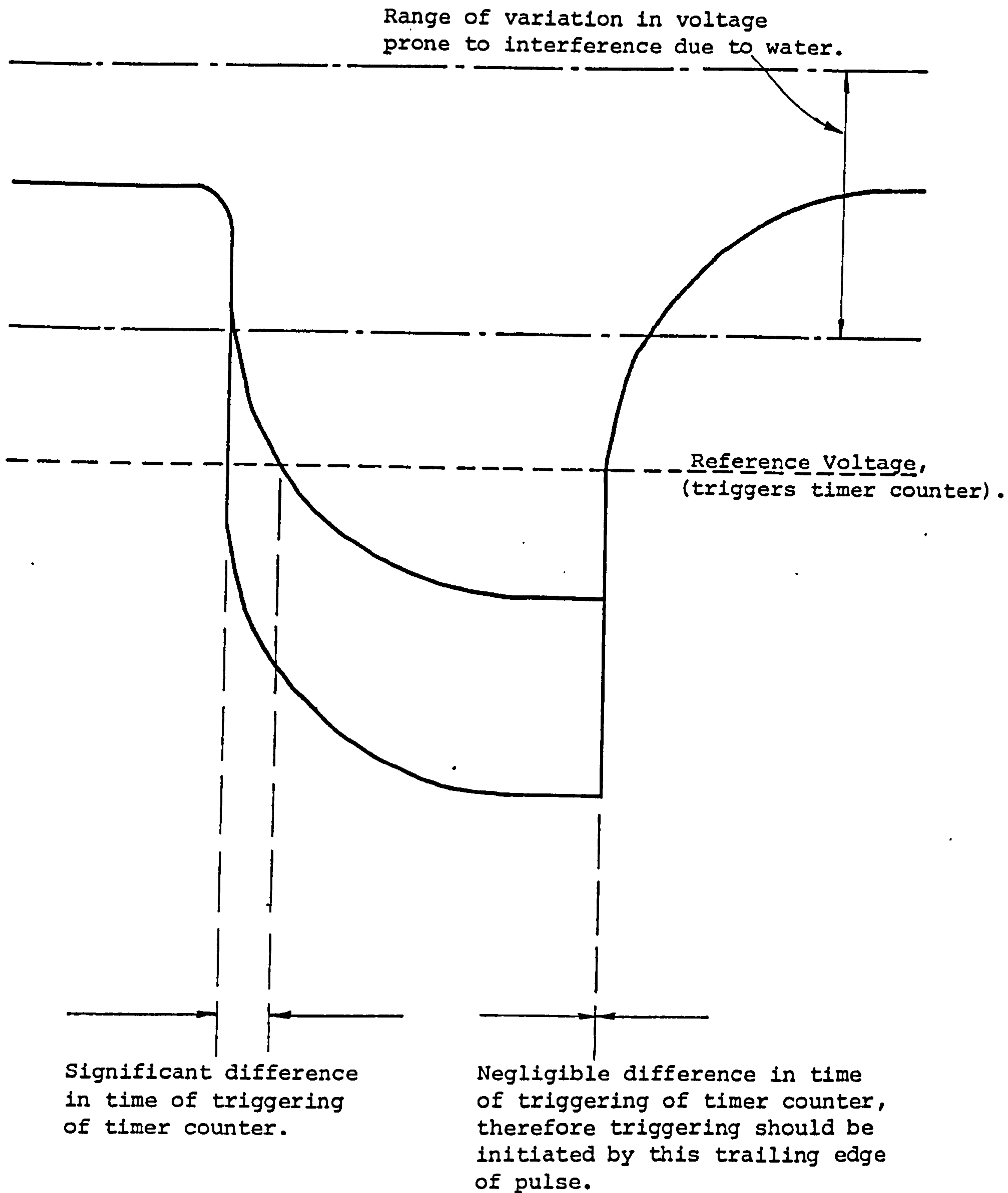

FIGURE 4/10. Variation of 'Change-Over Points', with Pulse Amplitude.

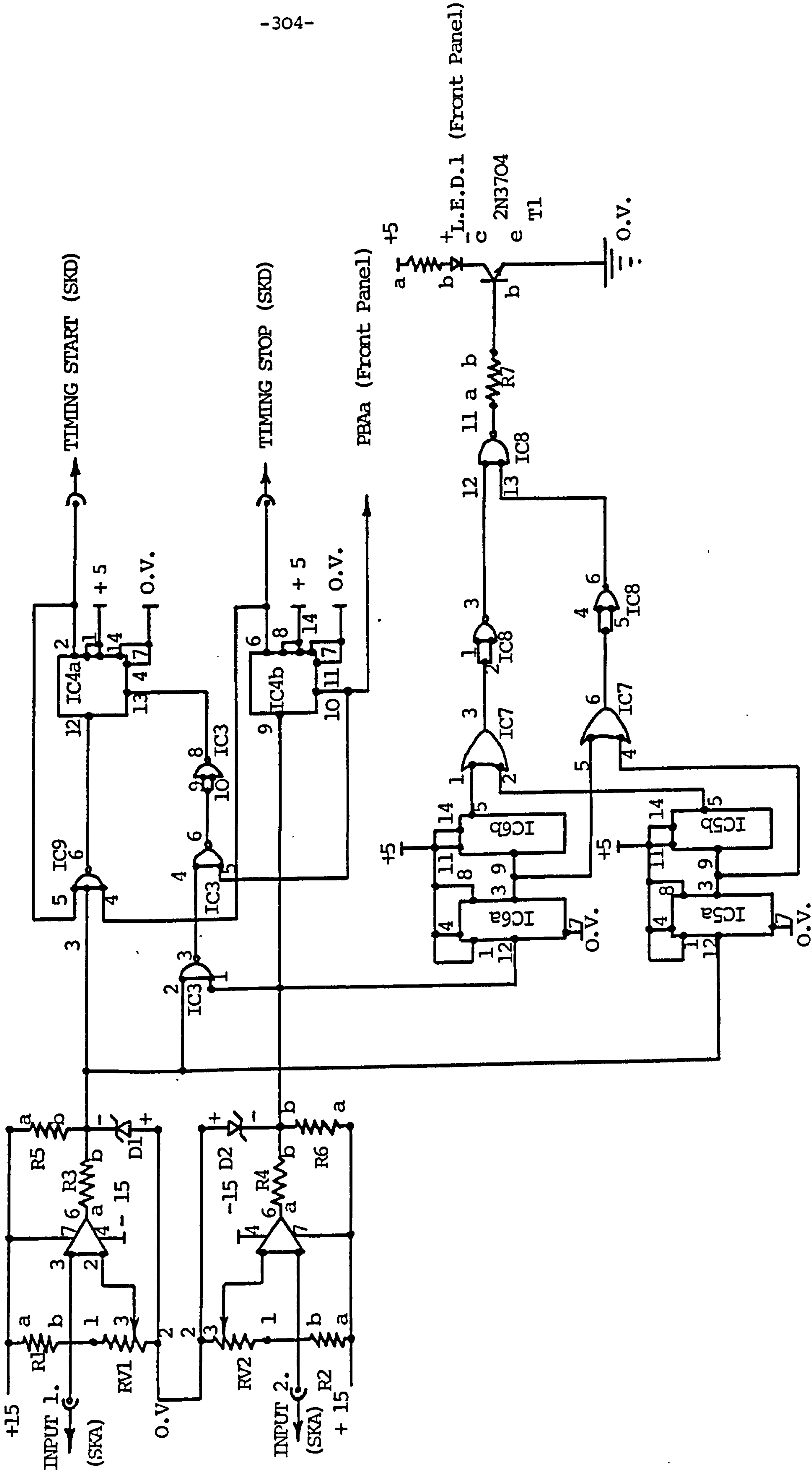

FIGURE 4/11. Circuit Diagram of 'Optically Triggered Time Logging Equipment', (O.T.T.L.E.).

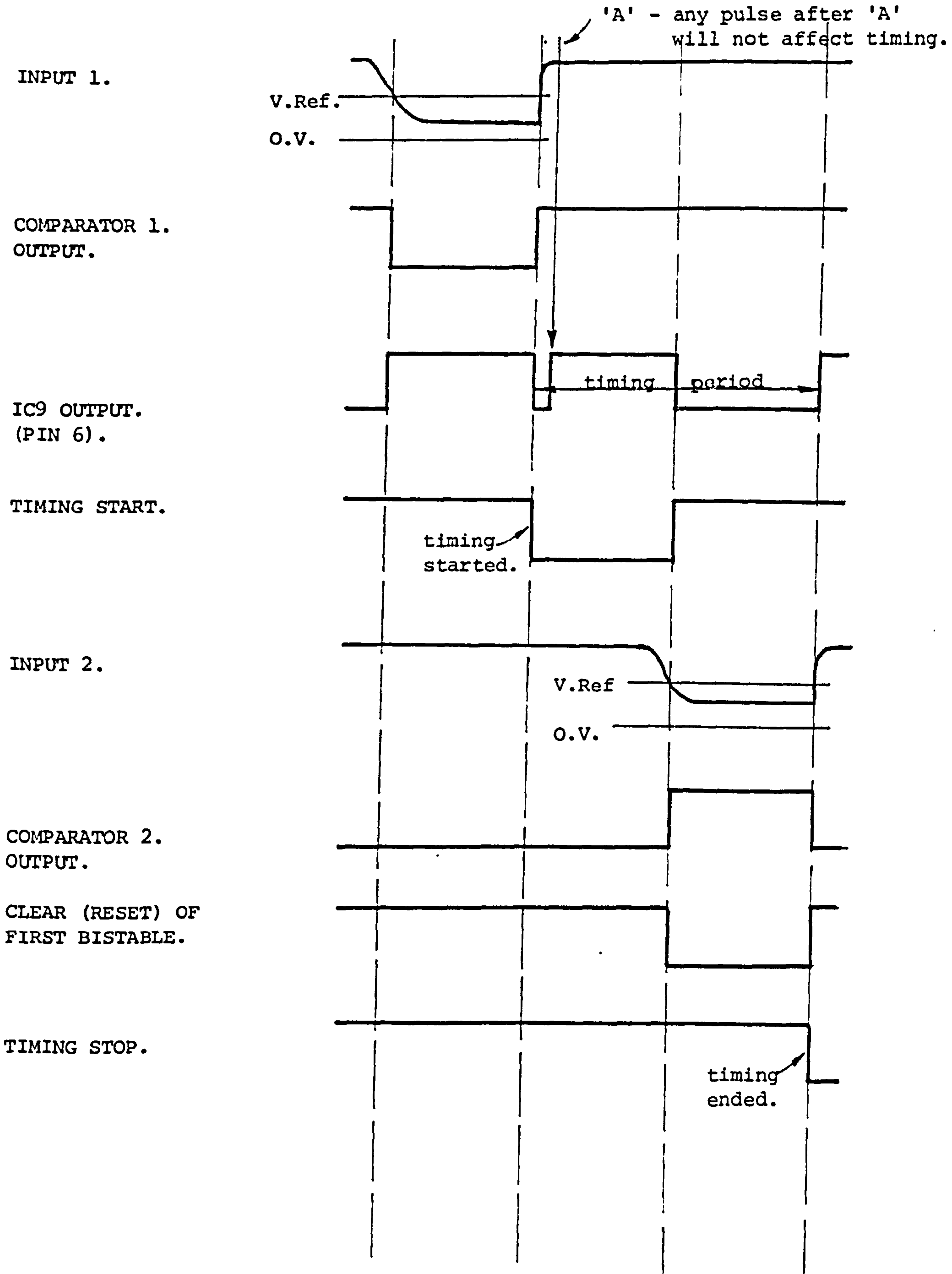

FIGURE 4/12.- Timing Diagram of O.T.T.L.E.

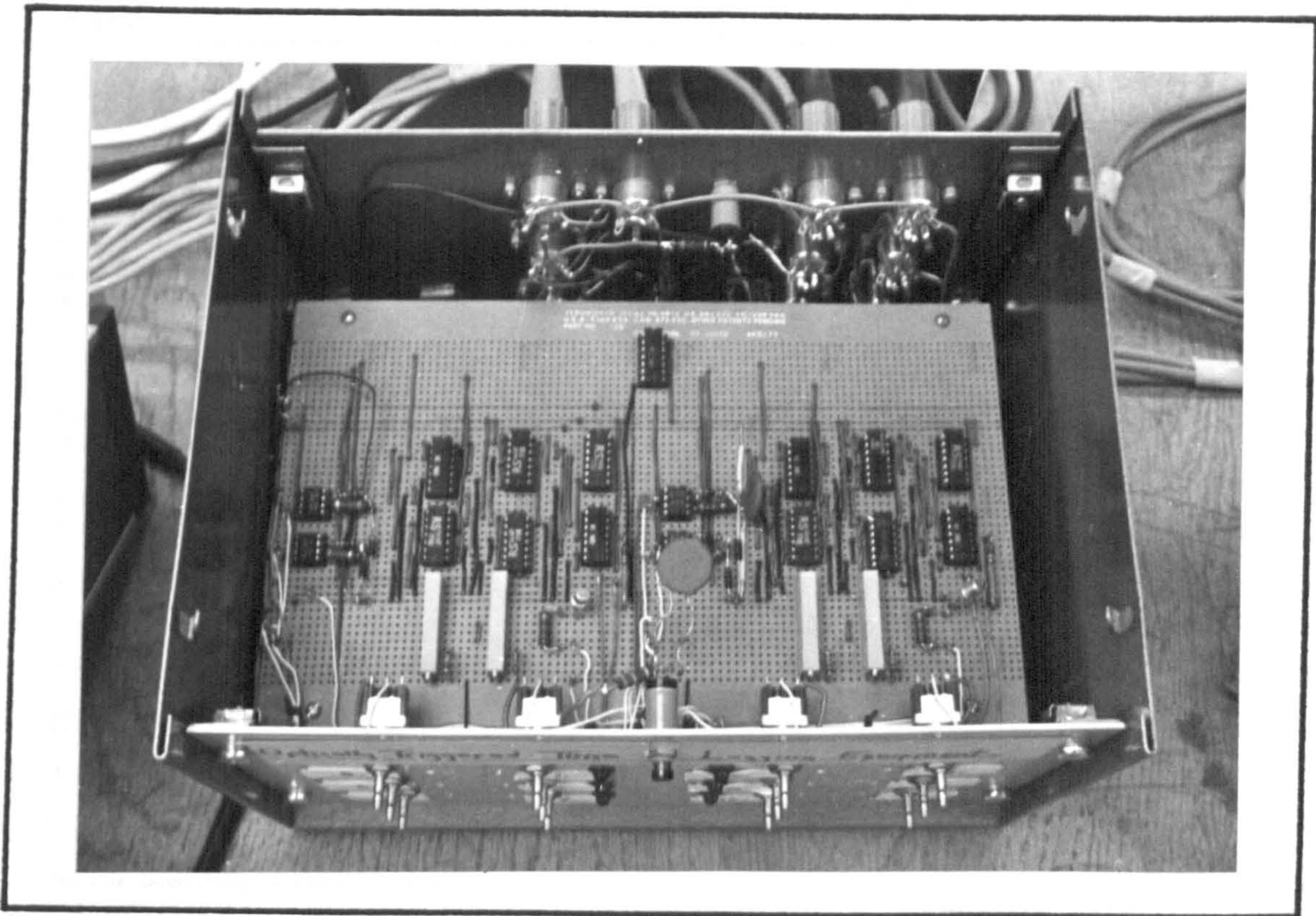

FIGURE 4/13. - Internal view of O.T.T.L.E.

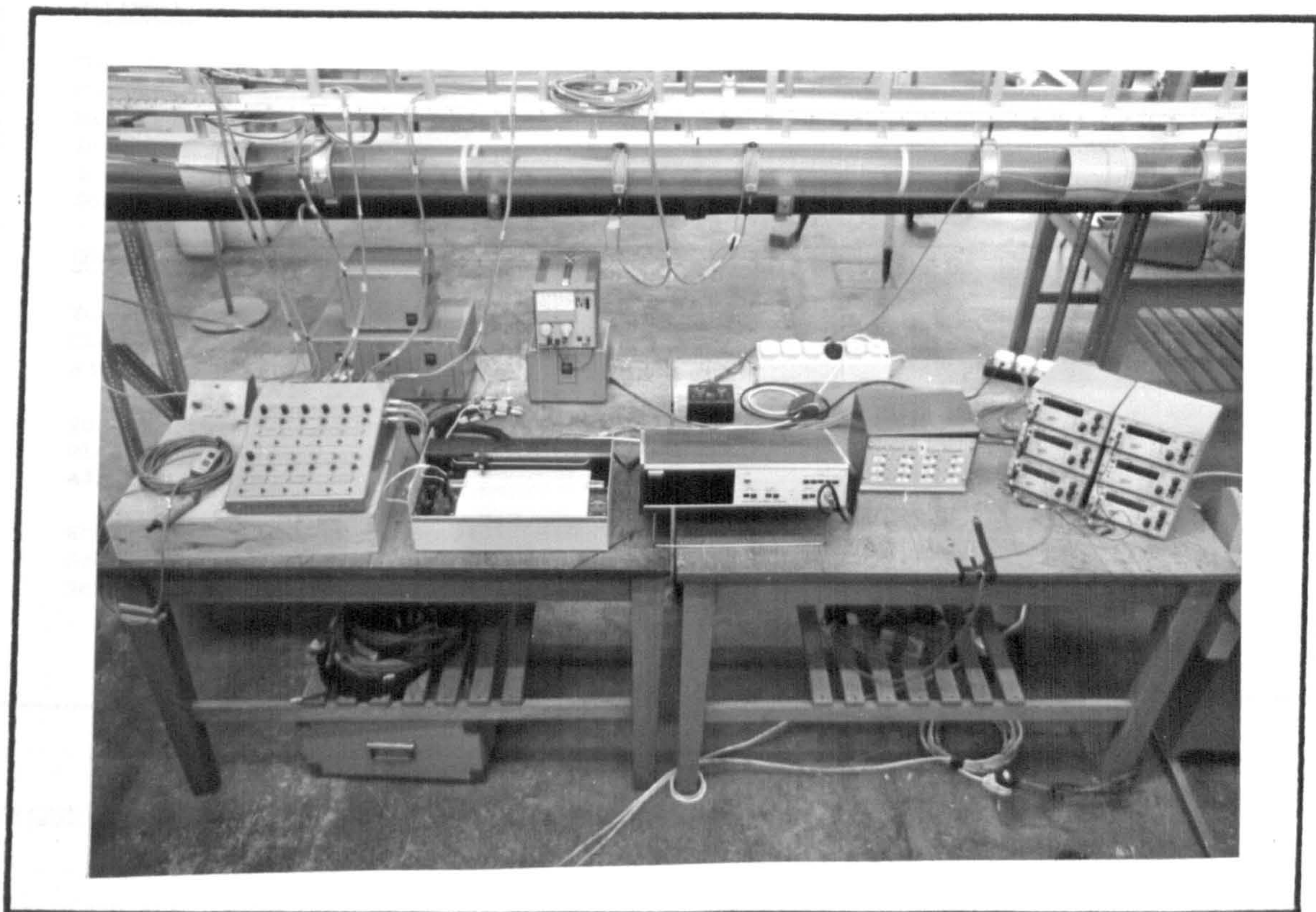

FIGURE 4/14. - Test Rig Instrumentation Table, (Laboratory Study).

MATERIAL INGESTED.	COLOUR OF STOOL.
Milk Diet	Light Yellowish-Brown
Meat Protein	Dark Brown
Spinach	Greenish
Carrots and Beets	Reddish
Chocolate, Cocoa	Dark Red or Deep Brown
High Fat Diet	Light Brown
Blood	Tarry Black
Senna, Rhubarb, Santonin	Yellowish
Calomel	Greenish
Bismuth, Iron, Charcoal	Black
Barium	Milk White

FIGURE 5/3. - INFLUENCE OF VARIOUS FOODS AND MEDICINES ON THE COLOUR OF THE STOOL (BUCKUS (1946)).

MATERIAL	WEIGHT (gm)	VOLUME (cm ³)	DENSITY (gm/cm ³)	SPECIFIC GRAVITY (at 20°C)
Porters Clay - Buff	488.6	237	2.062	2.046
Be. St. Thomas	513.7	254	2.022	2.026
Salm/Cream	520.9	269	2.048	2.052
Craft/Cream	581.2	280	2.076	2.080
Flour Putty	230.6	183	1.260	1.282
P.V.A. Powder - Colvitol				
1 - 20	99.9	95	1.049	1.091
20 - 90	94.5	95	1.027	1.079
80 - 10	88.1	83	1.119	1.121

FIGURE 5/4. - SPECIFIC GRAVITIES OF MATERIALS UNDERSUED AS SUBSTITUTES FOR ENRICHED C. LAMMARTINI TABLETS.

COMPONENT	WEIGHT (gm)	PER CENT OF TOTAL
Bulk	150	
Water	99	66.0
Dry Matter	27	17.8
Fat	4.7	3.0
Protein	7	?
Nitrogen	1.5	1.0
Carbohydrate	?	?
Minerals	2.1	1.4
Sodium	0.12	
Potassium	0.67	
Calcium	0.64	
Magnesium	0.20	
Chloride	0.09	
Phosphorus	0.51	
Sulphur	0.13	
Trace Elements		
Copper		
Iron		
Lead		
Manganese		
Nickel		
Zinc		
Zirconium		
Antimony		
Vanadium	0.015	0.01
Bismuth	0.150	0.10

Aspartic acid and L-histidine (1953)

FIGURE 5/5. - SUMMARY OF THE VARIOUS ANALYTICAL CONCENTRATIONS OF VARIOUS ELEMENTS.



FIGURE 5/5. - A Variety of the Different 'Models' Produced From P.V.A. Powder, (With and Without 'Filler' Materials).

SOLID NUMBER.	F1	F2	M1	M2	C1	C2
GRADE OF SPONGE.	Fine	Fine	Medium	Medium	Coarse	Coarse
DRY LENGTH (mm.)	124.0	124.7	126.4	127.7	126.0	126.2
WET LENGTH (mm.)	138.8	139.1	140.0	141.1	139.3	139.3
DRY DIAMETER (mm.)	33.9	33.9	34.5	34.5	34.4	35.0
WET DIAMETER (mm.)	39.7	39.2	39.1	38.6	37.8	38.3
APPROX. WET VOL. INCLUDING ALL INTERNAL CAVITIES AND THEIR CONTENTS (c m. ³).	171.8	167.9	168.1	165.1	156.3	160.5
EXTENSION IN LENGTH, DRY TO WET (%).	11.9	11.5	10.8	10.5	10.6	10.4
EXTENSION IN WIDTH, DRY TO WET (%).	17.1	15.6	13.3	11.9	9.9	9.4
VOLUME OF MATERIAL OF SPONGE AND WATER CONTENT WHILE DAMP (APPARENT VOLUME) (g m.).	22	22	15	16	15	15
WEIGHT OF MATERIAL OF SPONGE AND WATER CONTENT WHILE DAMP (APPARENT WEIGHT) (g m.).	20.80	20.90	17.15	18.00	15.70	15.55
APPARENT DENSITY (g m./c m. ³).	0.945	0.950	1.143	1.125	1.047	1.037
APPARENT SPECIFIC GRAVITY.	0.947	0.952	1.145	1.127	1.049	1.039
REQUIRED WEIGHT FOR APPARENT SPECIFIC GRAVITY TO EQUAL 1.05 (g m.).	23.058	23.058	15.722	16.770	15.722	15.722
REQUIRED WEIGHT MINUS APPARENT WEIGHT (g m.).	+2.26	+2.16	- 1.43	-1.23	+ 0.02	+ 0.17

Assumed Room Temp., 20°C., - Density of Water, 0.9982 gm/cm³.

FIGURE 5/6. - Specification of P.V.A. Sponge 'Model' Solids.

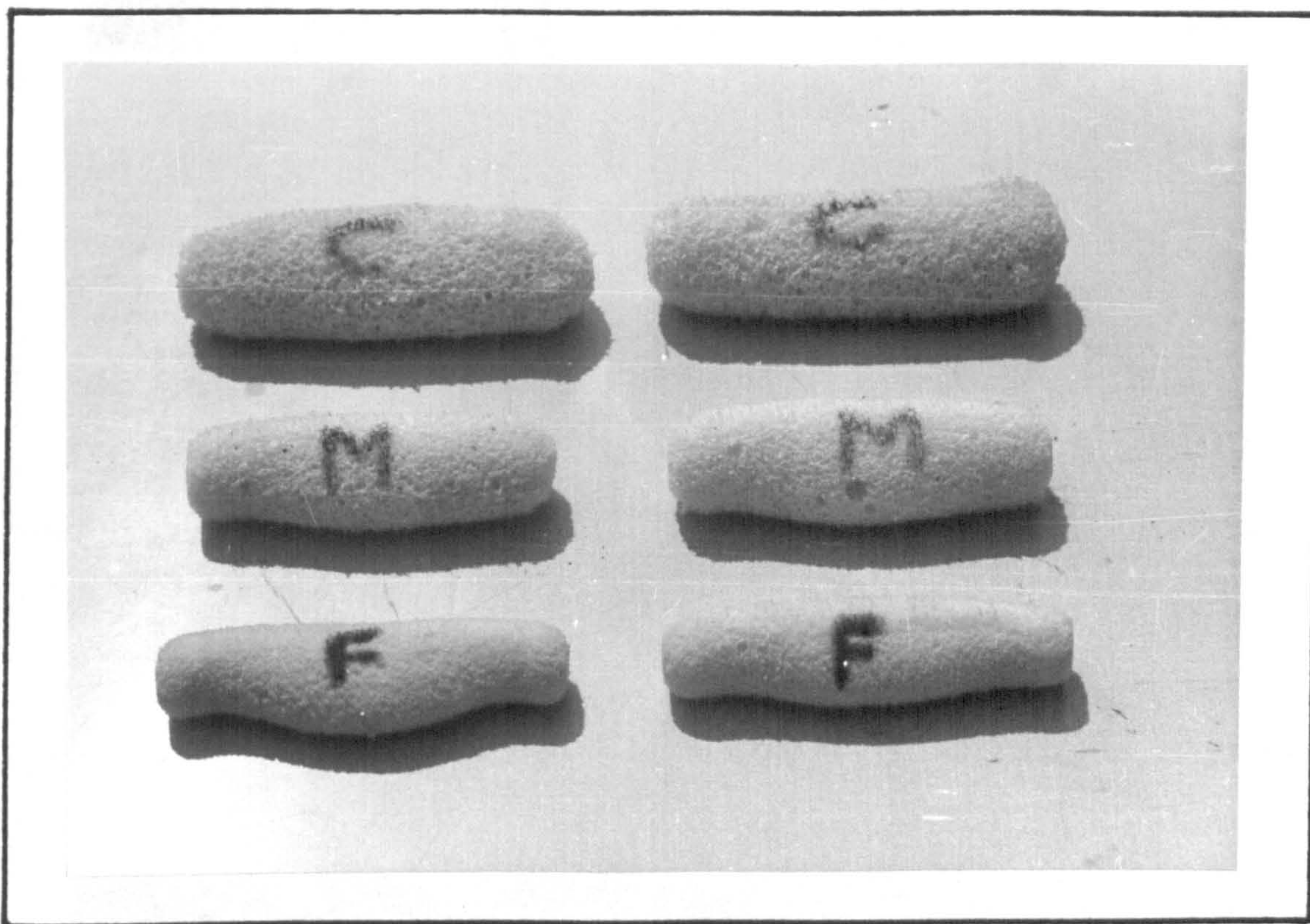

FIGURE 5/7. - Early Attempts at Producing P.V.A. Sponge 'Models',
Solids Pictured in 'Wet State' Condition.

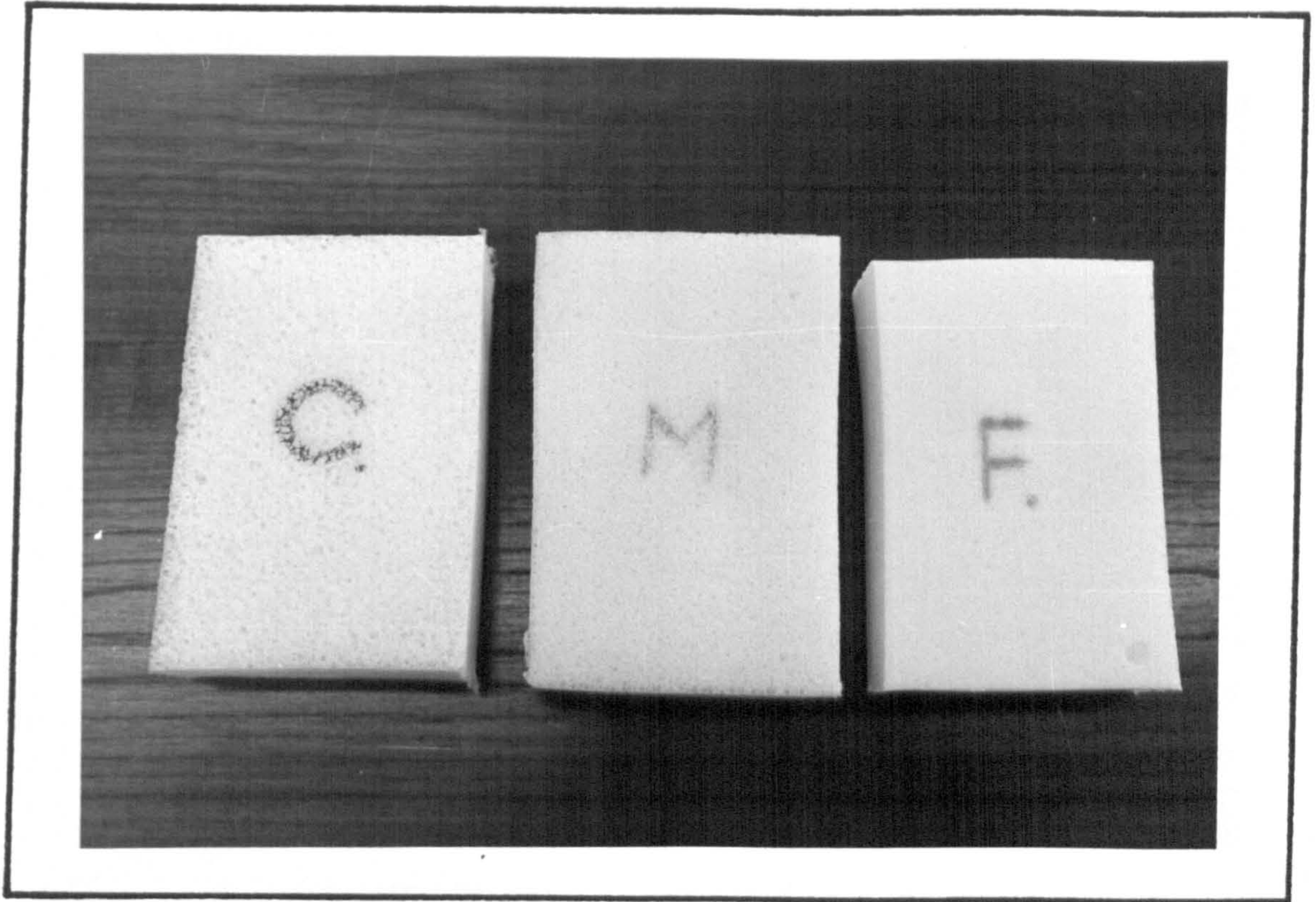

FIGURE 5/8. - Original P.V.A. Sponge Blocks, Pictured in 'Wet State' Condition.



FIGURE 5/9. - Original P.V.A. Sponge Blocks, Pictured in 'Dry State' Condition.

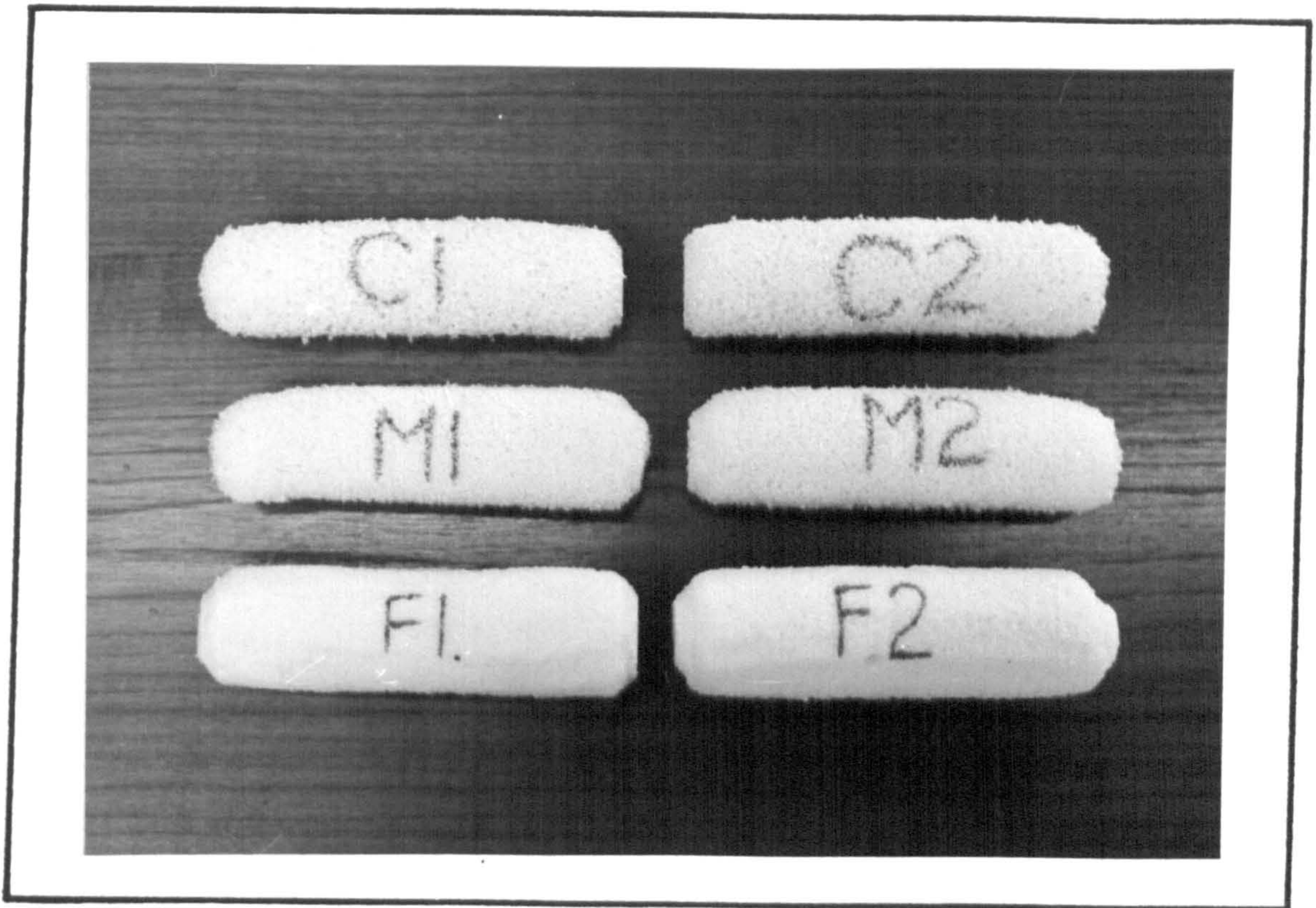

FIGURE 5/10. - P.V.A. Sponge 'Models', as Employed in Laboratory Investigations, Pictured in 'Wet State' Condition.

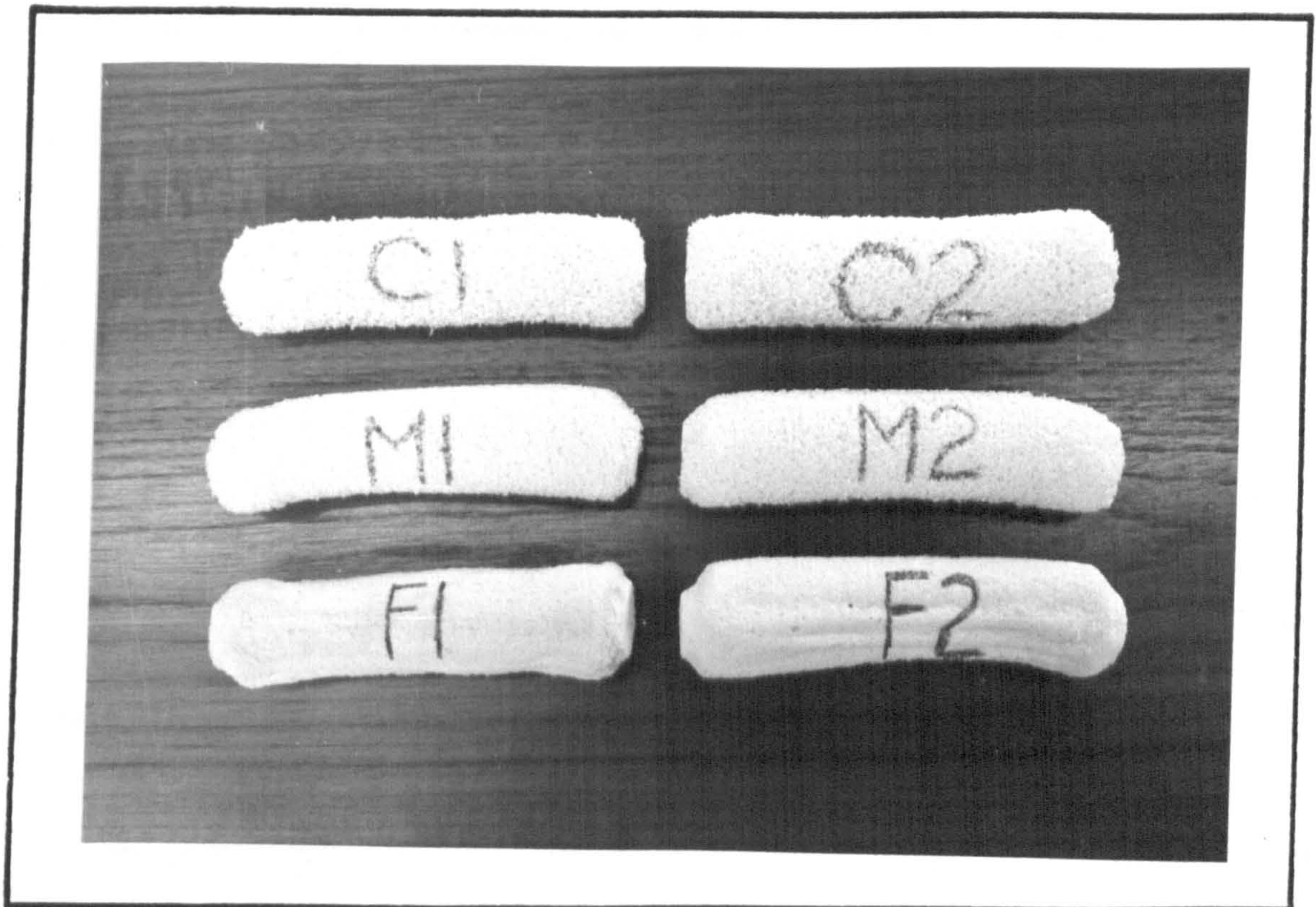

FIGURE 5/11. - P.V.A. Sponge 'Models', as Employed in Laboratory Investigations, Pictured in 'Dry State' Condition.

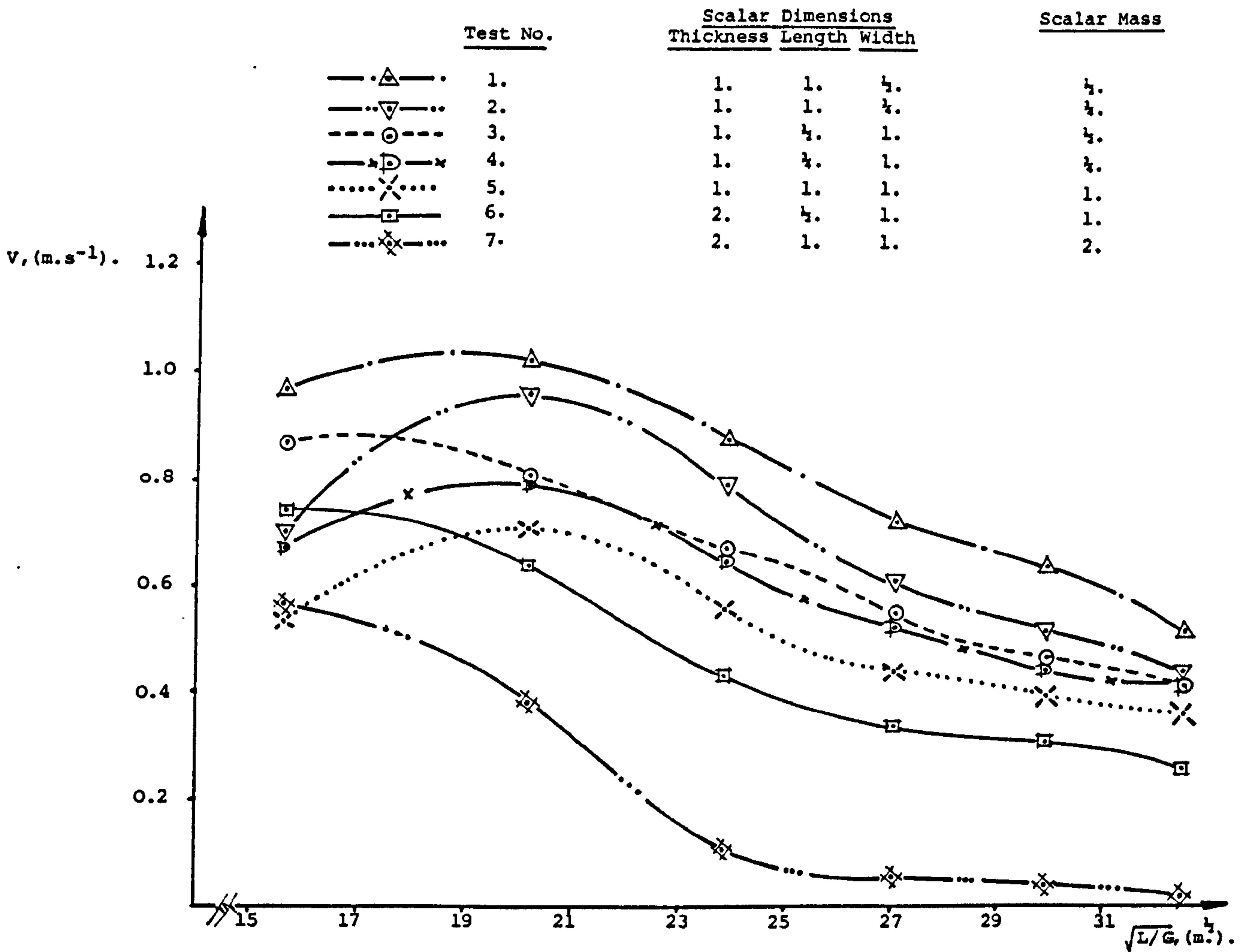

FIGURE 6/1. - VARIATIONS IN PERFORMANCE RESULTING WITH PARTICULAR VARIATIONS IN THE DIMENSIONAL PARAMETERS OF MATERNITY PAD 'MODEL' SOLIDS.

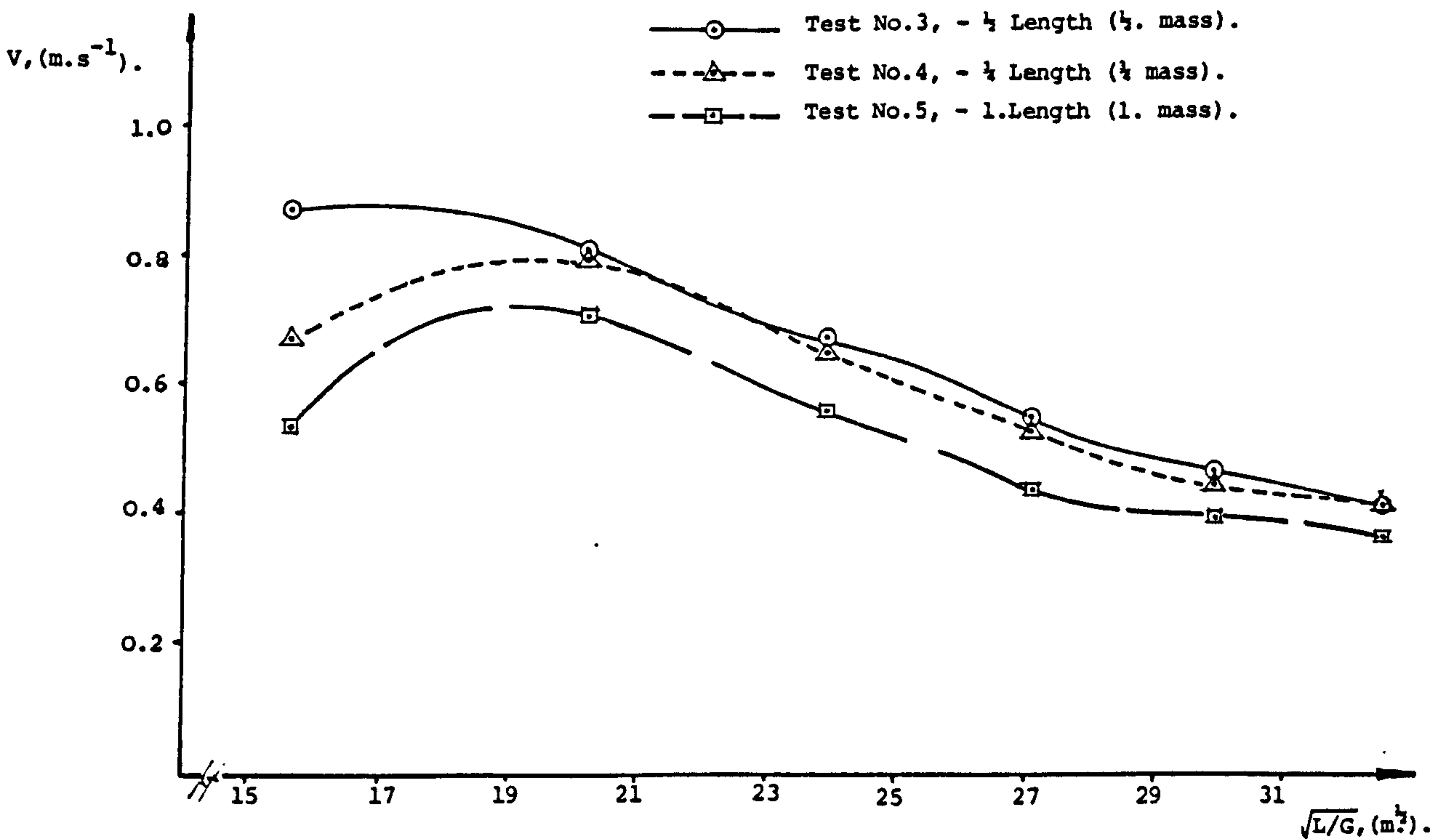

FIGURE 6/2. - VARIATIONS IN PERFORMANCE RESULTING WITH PARTICULAR VARIATIONS IN LENGTH (MASS), OF MATERNITY PAD 'MODEL' SOLID.

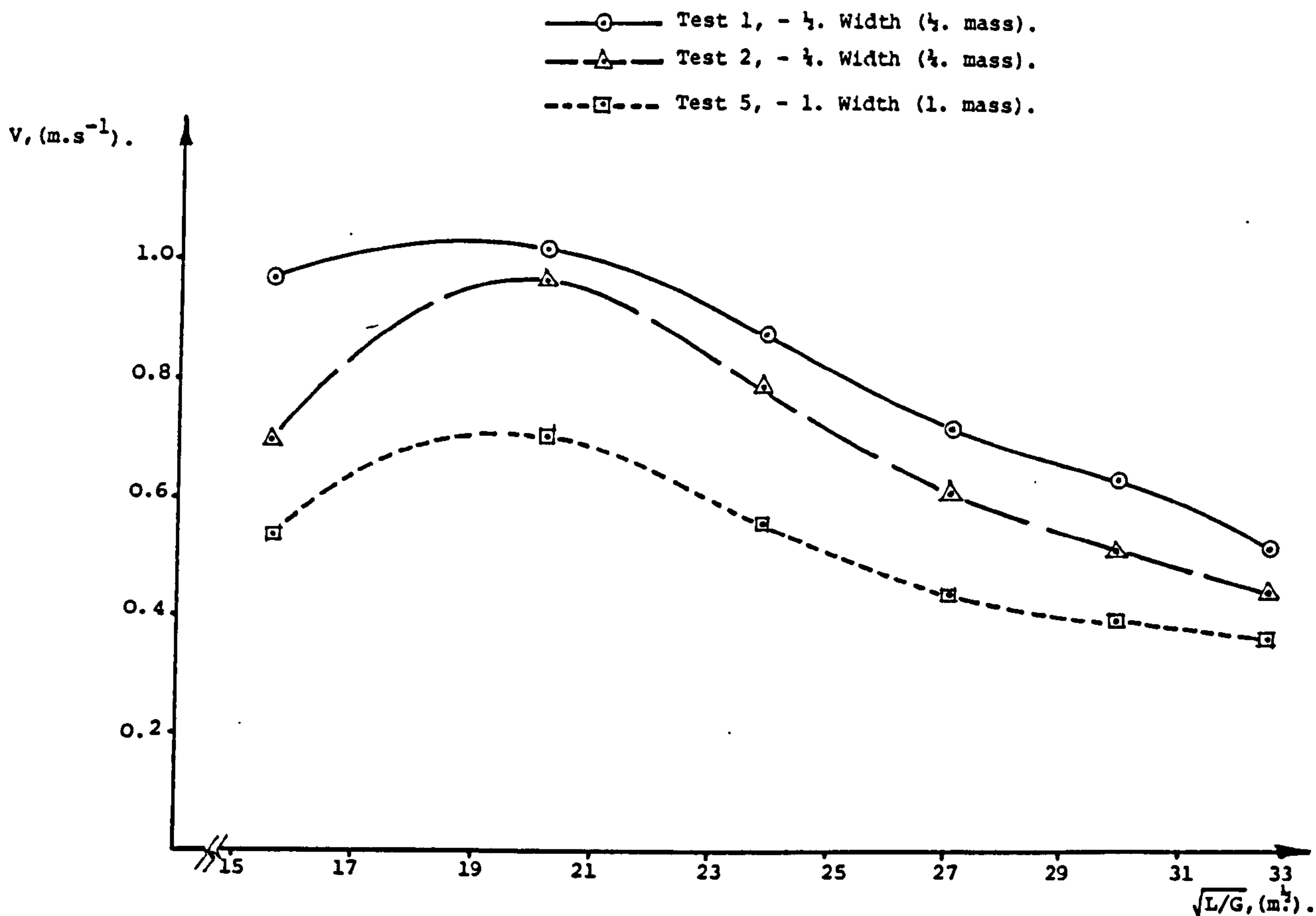

FIGURE 6/3. - VARIATIONS IN PERFORMANCE RESULTING WITH PARTICULAR VARIATIONS IN WIDTH (MASS), OF MATERNITY PAD 'MODEL' SOLID.

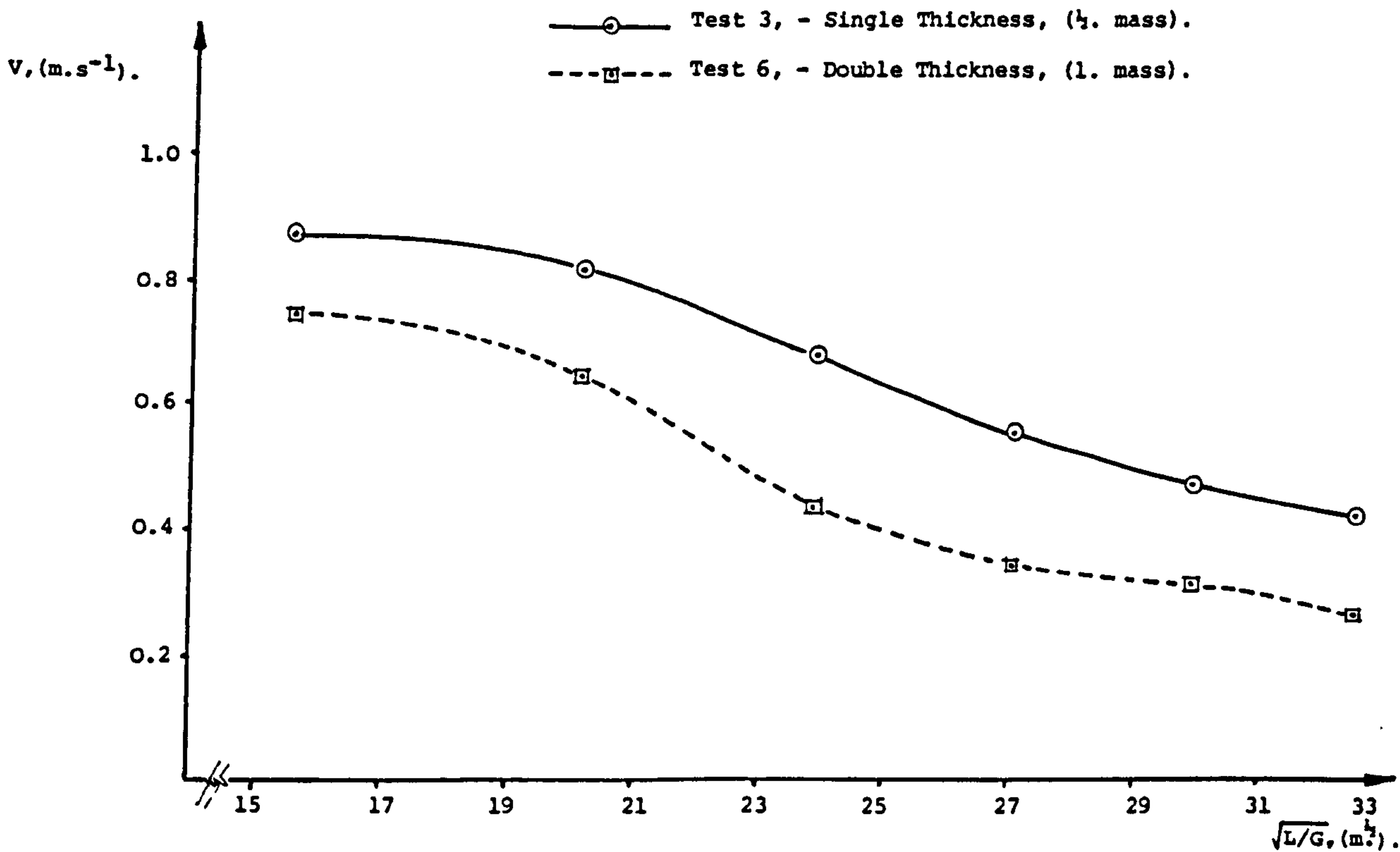

FIGURE 6/4. - VARIATIONS IN PERFORMANCE RESULTING WITH PARTICULAR VARIATIONS IN THICKNESS (MASS), OF MATERNITY PAD 'MODEL' SOLID.

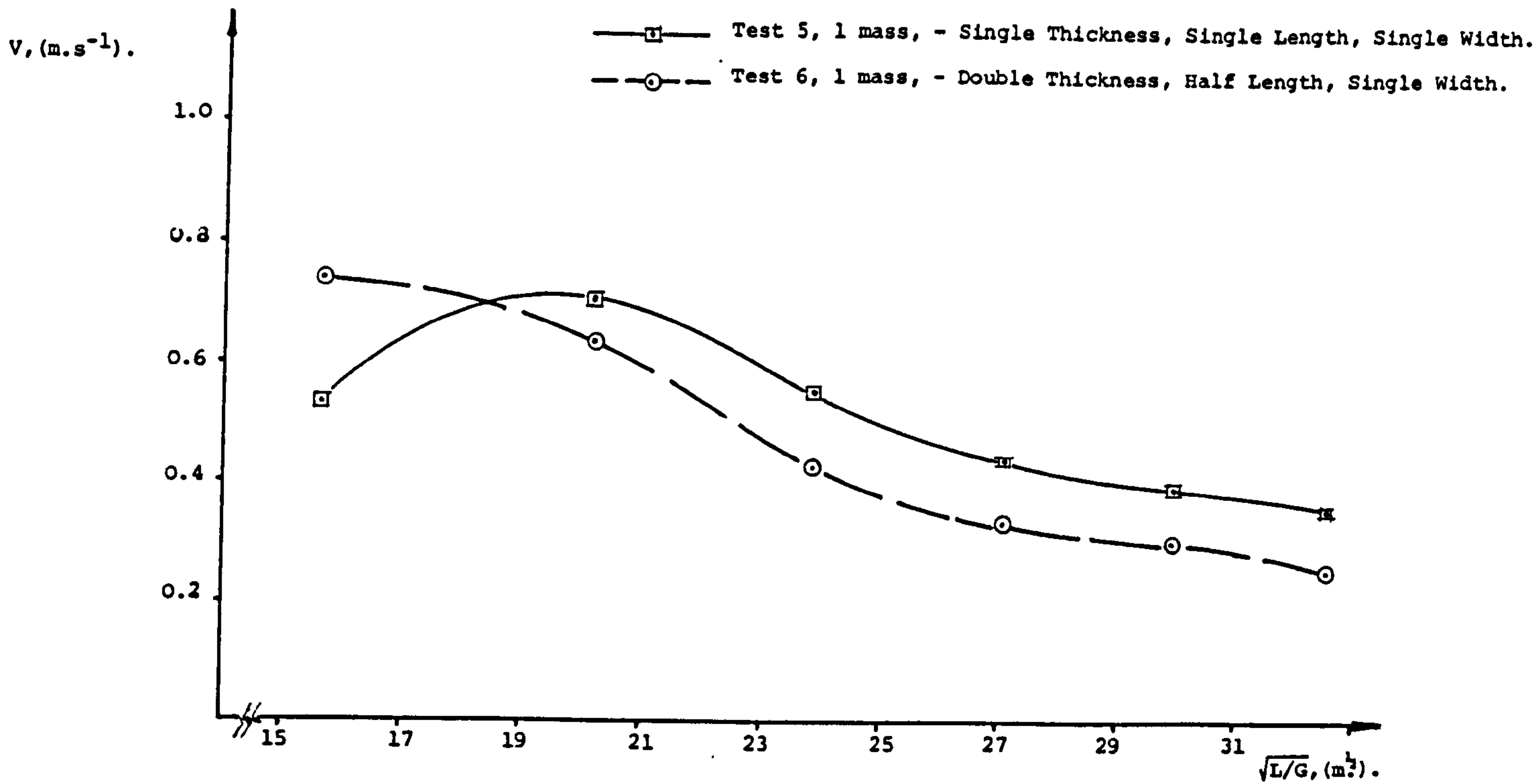

FIGURE 6/5. - VARIATIONS IN PERFORMANCE RESULTING WITH PARTICULAR LENGTH/THICKNESS ADJUSTMENTS (FOR CONSTANT MASS), TO THE MATERNITY PAD 'MODEL' SOLID.

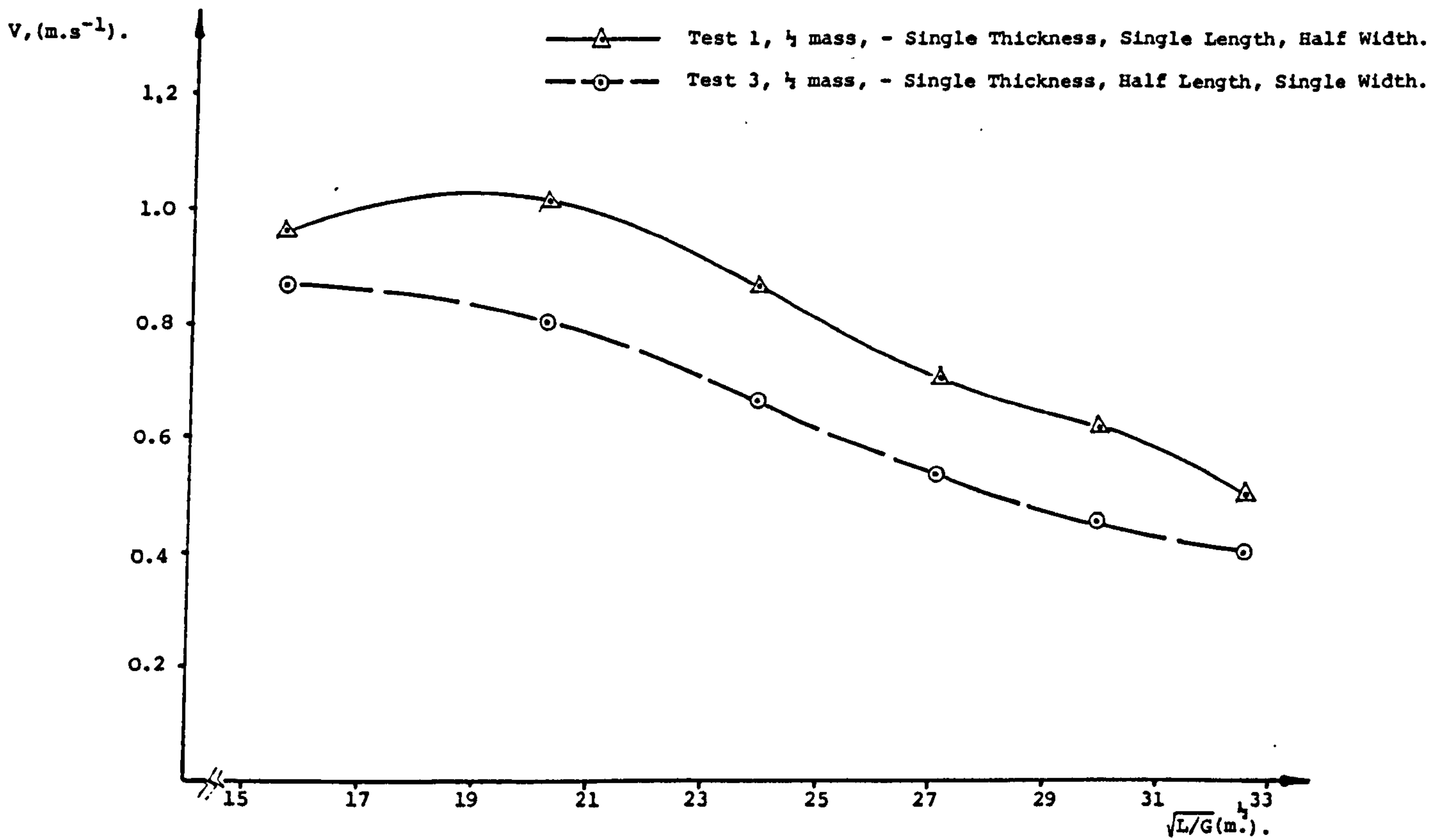

FIGURE 6/6. - VARIATIONS IN PERFORMANCE RESULTING WITH PARTICULAR LENGTH/WIDTH ADJUSTMENTS (FOR CONSTANT MASS), TO THE MATERNITY PAD 'MODEL' SOLID.



FIGURE 8/1. - Inlet to Discharge Pipe, ('On-Site').



FIGURE 8/2. - Connection of 'Branch-Line' W.C. Pan to Main Straight Length of Monitored Pipework, ('On-Site').

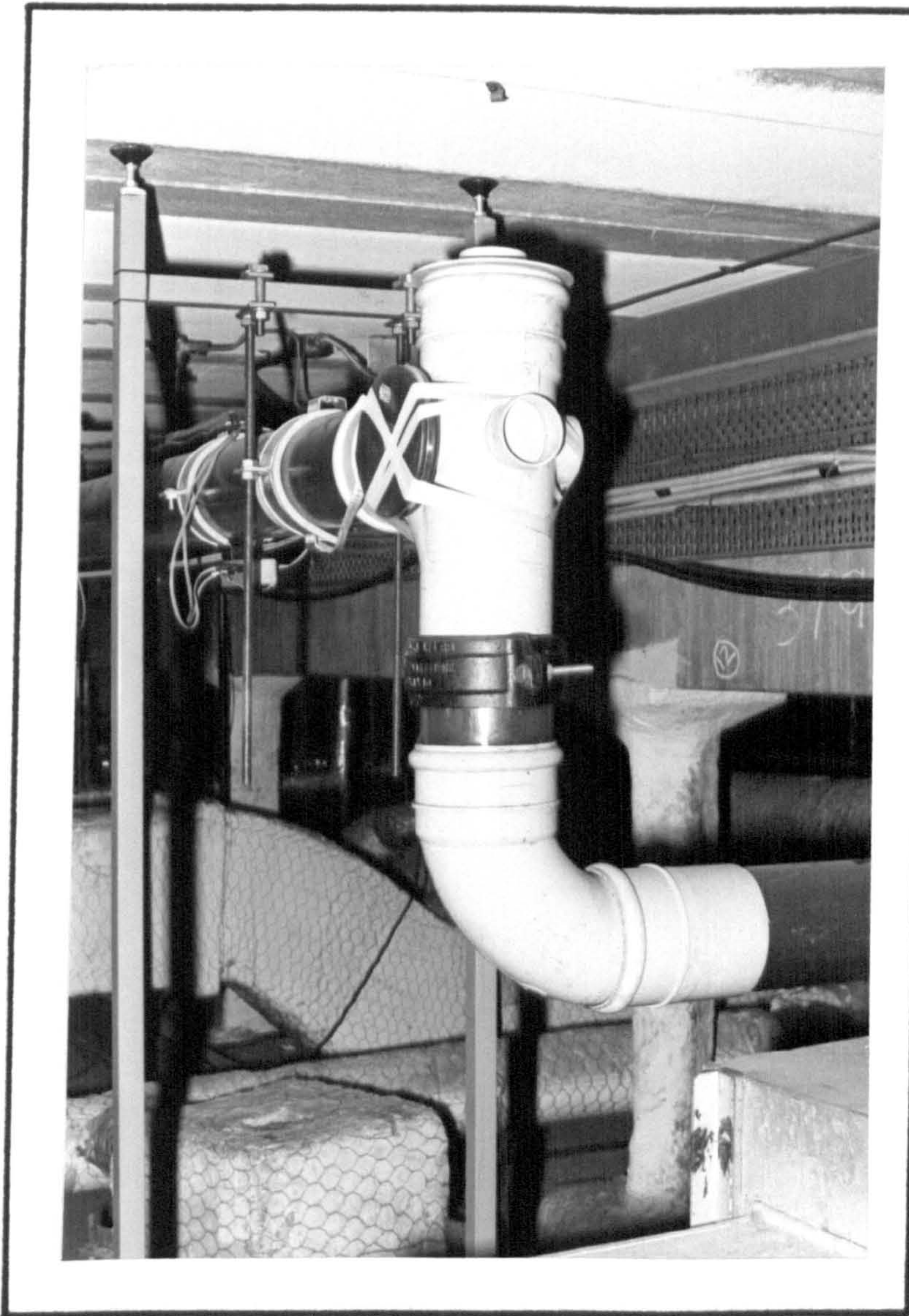
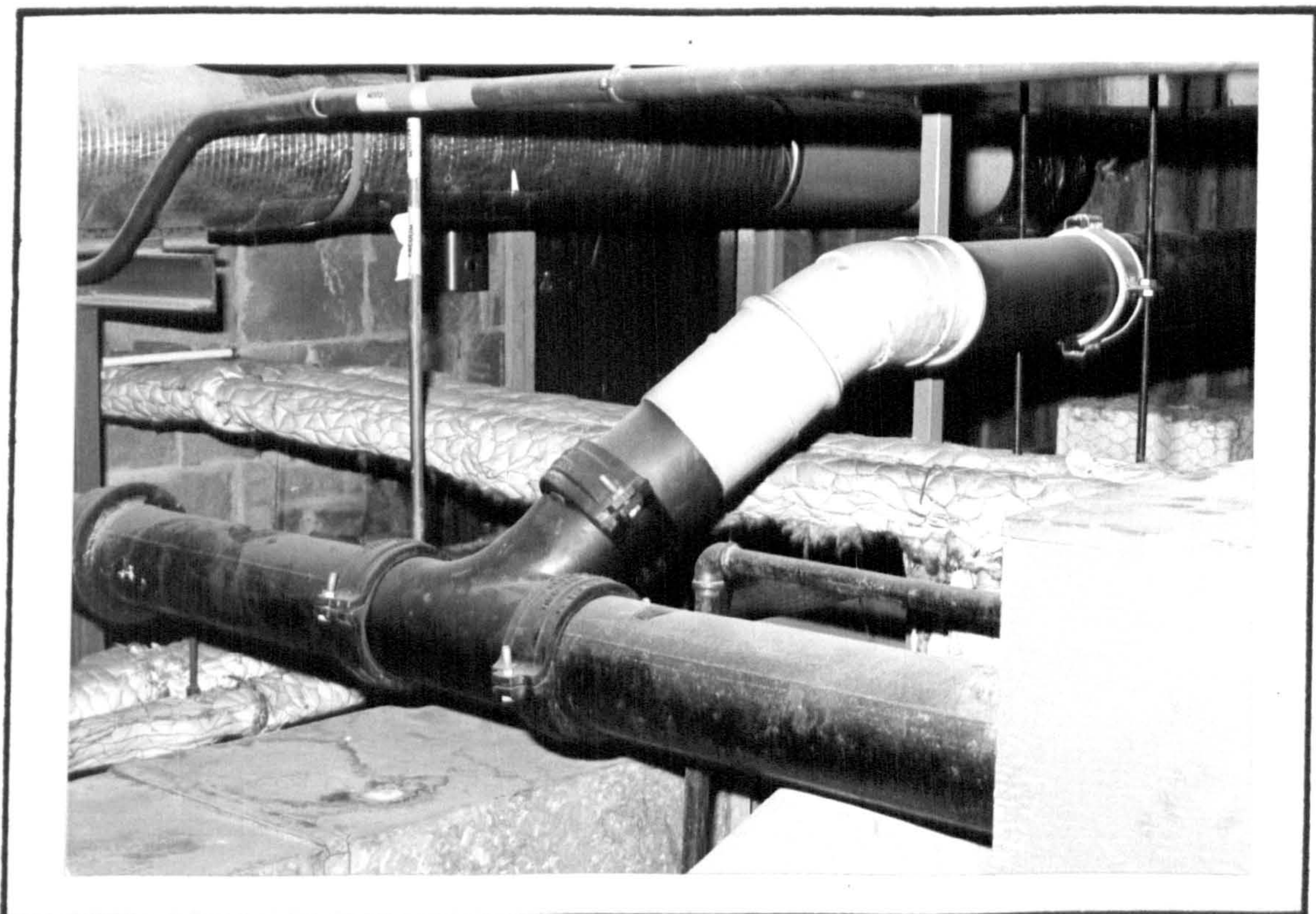

FIGURE 8/3.
Outlet from
Main Straight
Length of
Monitored Pipework,
('On-Site').

FIGURE 8/4.
Connection of
Newly Installed
U.P.V.C. Pipework
to Original C.I. Main,
('On-Site').



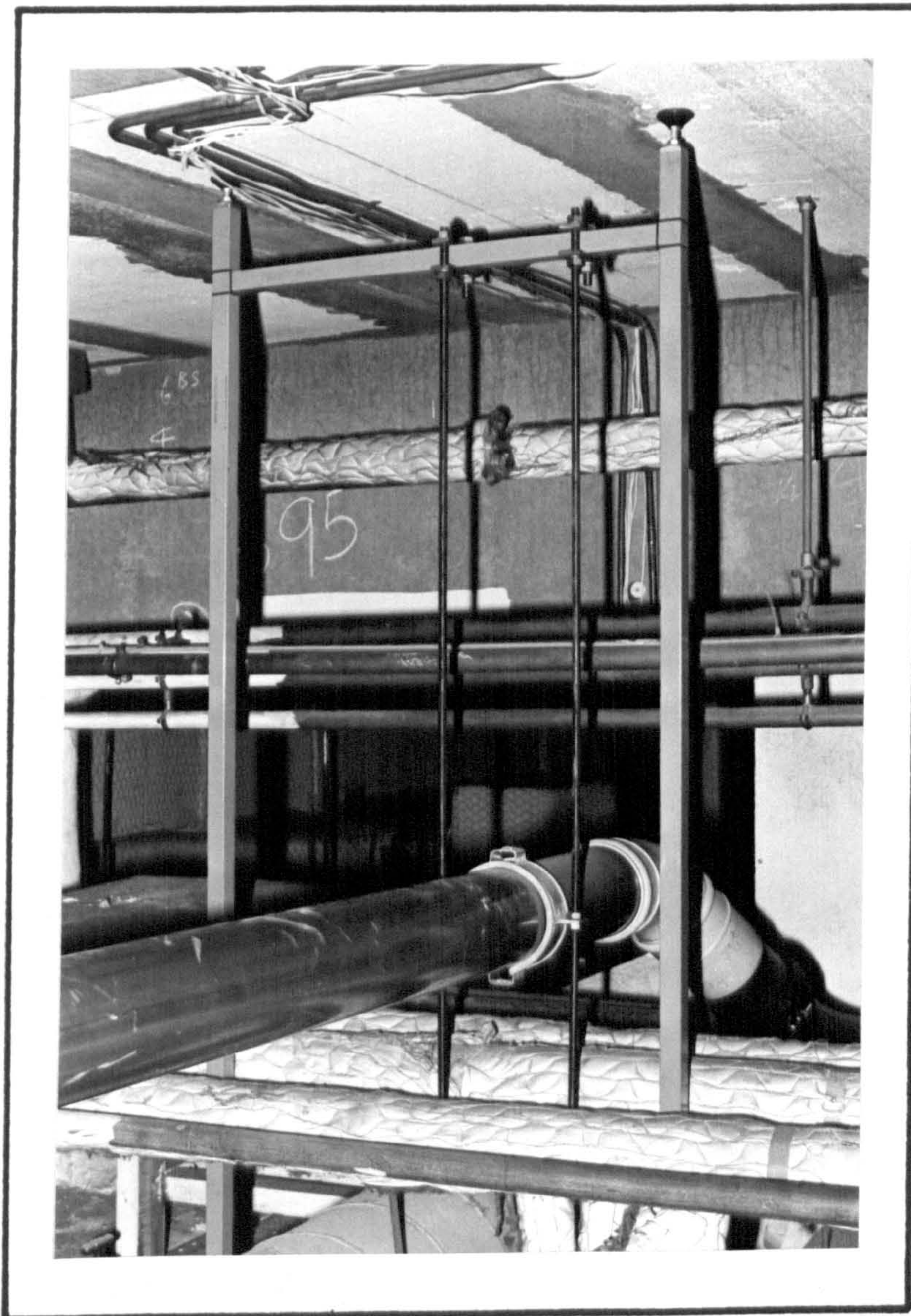
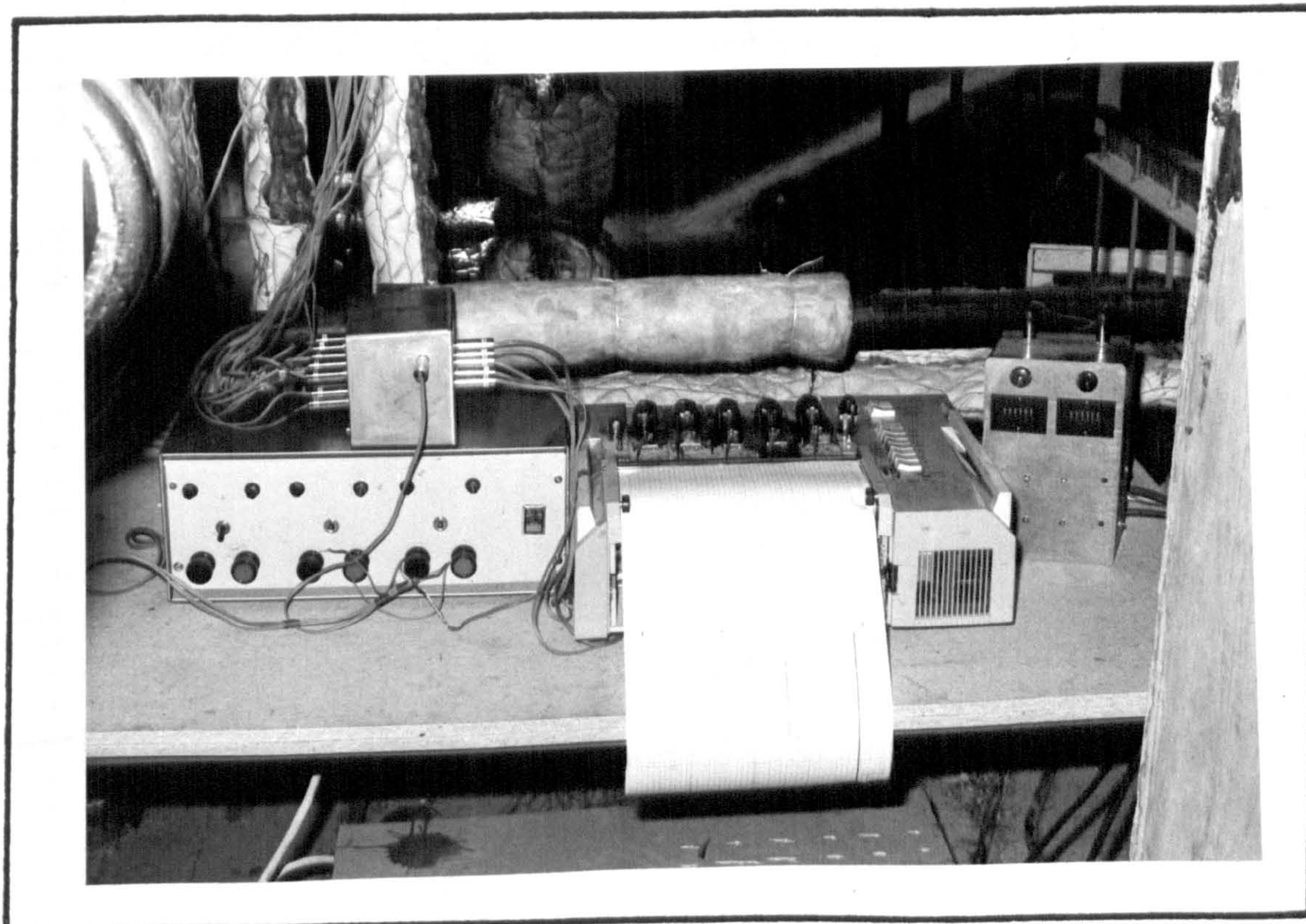

FIGURE 8/5.
Method of
Pipe Support,
('On-Site')

FIGURE 8/6.
Test Rig Instrumentation
Table ('On-Site').



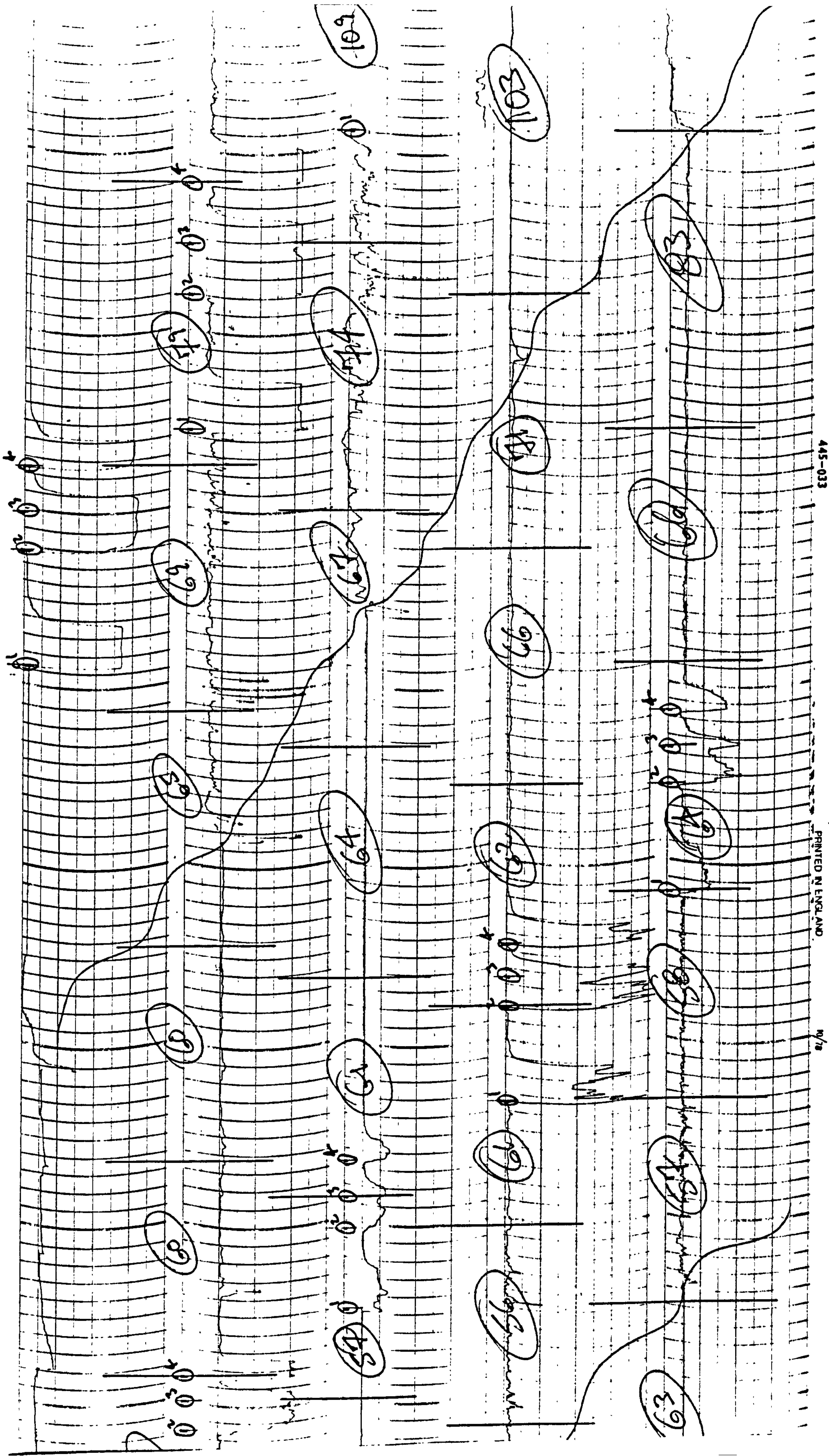
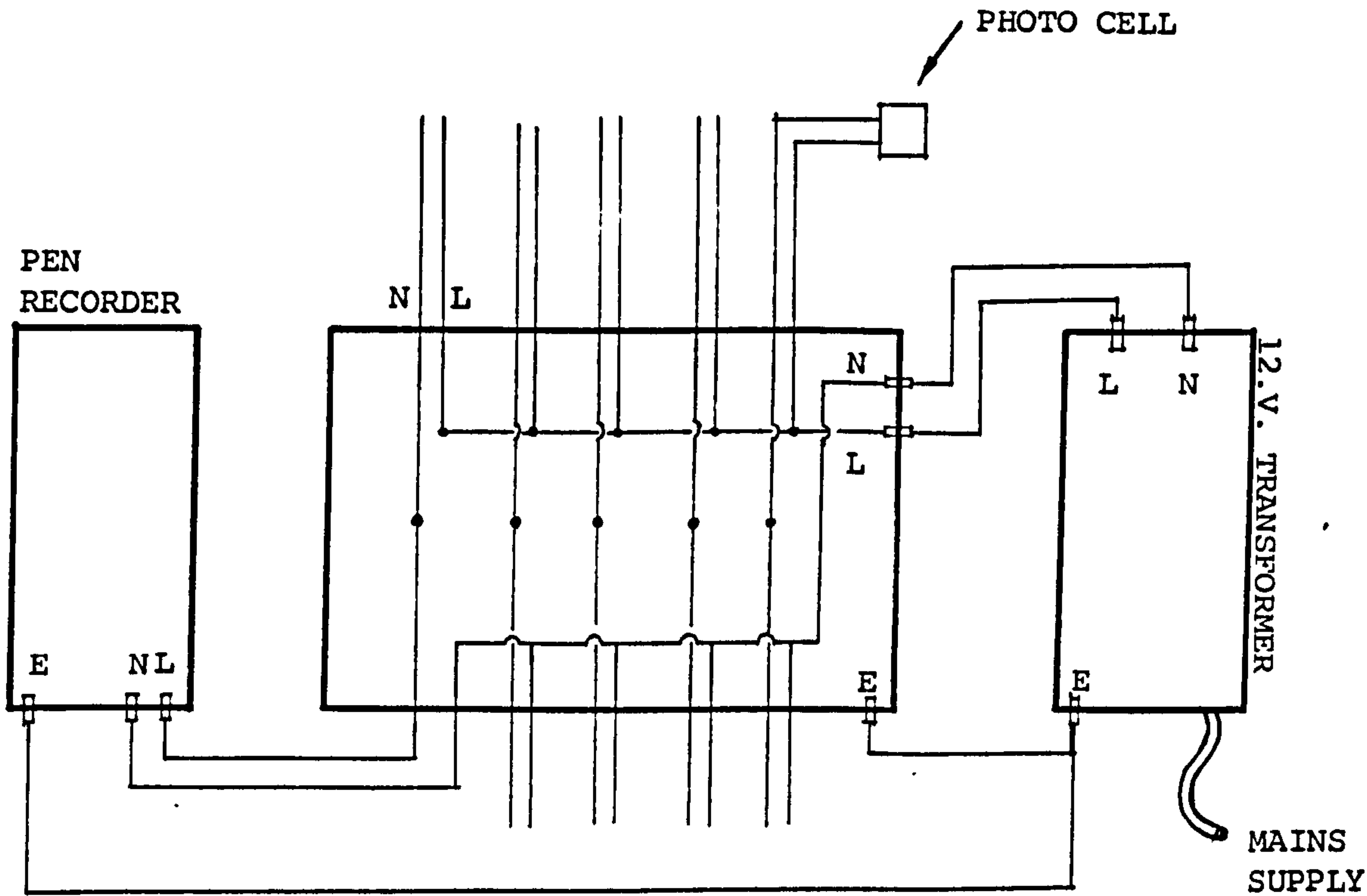

FIGURE 8/7. - 'Zoned' Pen Recorder Trace Out - Sample Segment.

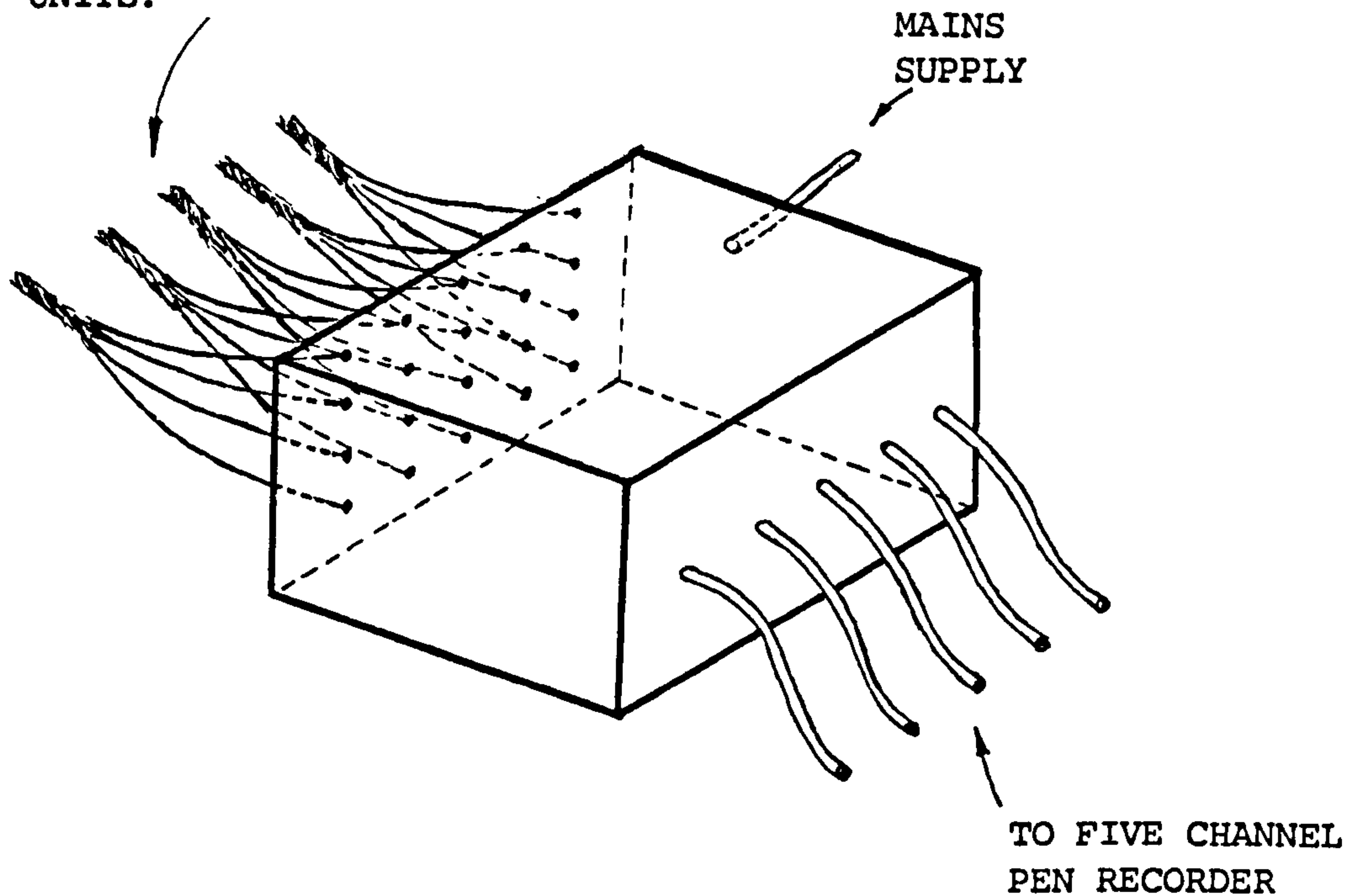

FIGURE 8/8. - Photo Cell / Light Source
Arrangement, ('On-Site').

8/9. A) CIRCUIT LAYOUT.



TO 20 (5x4),
PHOTO CELL/LIGHT SOURCE
UNITS.



8/9. B) ISOMETRIC.

FIGURE 8/9. - Schematic Layout of 'Terminal Box'.



FIGURE 8/10. - Installed 'Float Switch',
('On-Site')

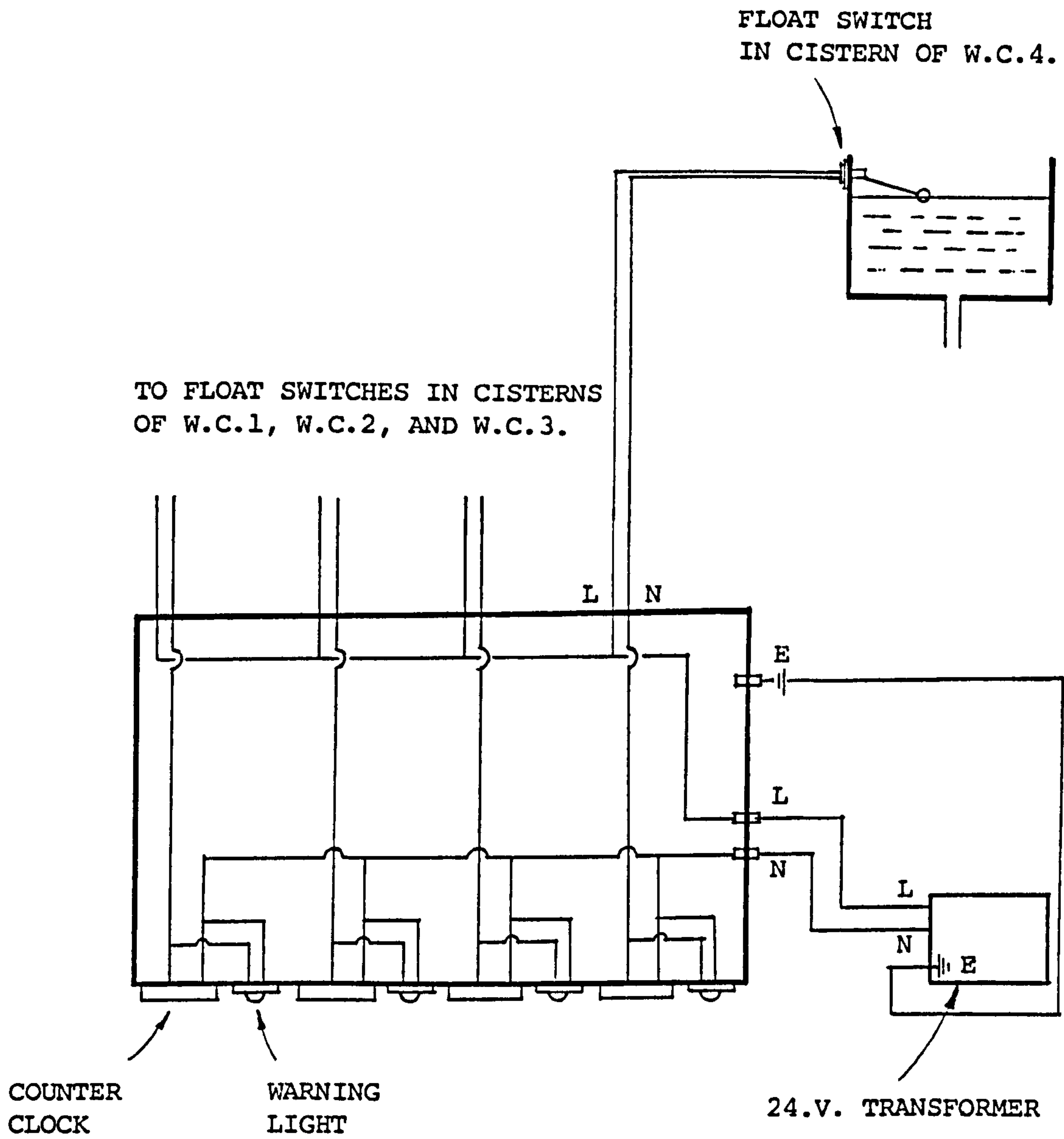

FIGURE 8/11. - Schematic Layout of Four Channel 'Cistern Operation Monitoring Console'.



FIGURE 8/12. - Cable to 'Float Switch' in Cistern Concealed inside 15 mm. (I.D.), U.P.V.C. Pipework.

A MATERIAL	B LENGTH	C DIAMETER/THICKNESS.	D	E	F
1. - Faecal Matter. 2. - Toilet/Tissue-Paper. 3. - Sanitary Towel. 4. - Tampon. 5. - FAECAL/TISSUE. 6. - Other, (Specified in Subscript to 'Run' Data). 7. - Diarrhoea.	1. - 12 mm. (4"), ± 6 mm. 2. - 25 mm. (1") 3. - 50 mm. (2") 4. - 75 mm. (3") 5. - 100 mm. (4") 6. - 125 mm. (5") ±12 mm. 7. - 150 mm. (6") 8. - 175 mm. (7") 9. - 200 mm. (8") 10. - 225 mm. (9") 11. - 275 mm. (11") 12. - 350 mm. (14") ±37 mm. 13. - 425 mm. (17") 14. - 500 mm. (20") 15. - 575 mm. (23") 16. - Greater than 612 mm. (>25"). 17. - Small 18. - Medium } re. tampons 19. - Large } etc. 0. - NOT APPROPRIATE.	1. - 6 mm. (1/4") 2. - 12 mm. (1/2") 3. - 19 mm. (3/4") 4. - 25 mm. (1") 5. - 31 mm. (1 1/4") ±3 mm. 6. - 37 mm. (1 1/2") 7. - 44 mm. (1 3/4") 8. - 50 mm. (2") 9. - 56 mm. (2 1/4") 10. - 62 mm. (2 1/2") 11. - Greater than 65 mm. (>2 1/2") 12. - Very Thin. 13. - Thin. 14. - Medium Thickness. 15. - Thick. 16. - Very Thick. 0. NOT APPROPRIATE	1. - Single Solid, (faecal). Components to 'Cluster' Faecal Solids, Assumed Spherical:- 2. - Unidentified. 3. - 2. off } 12 mm. (1/2"), 10. - 9. off } diam. 11. - 10 or more } components 12. - 2. off } 19 mm. (3/4"), 19. - 9. off } diam., 20. - 10 or more } components 21. - 2. off } 25 mm. (1"), 28. - 9. off } diam., 30. - 10 or more } components 31. - HEAVILY USED. 32. - USED. 33. - NOT OBVIOUSLY USED. 0. - NOT APPROPRIATE.	1. - Tending to Float. 2. - Not Tending to Float. 3. - Flat. 4. - Wedge Shaped. 5. - Irregular. 6. - Folded. 0. - NOT APPROPRIATE.	1. - Stool(s) Following Paper, (As One). 2. - Stool(s) Leading Paper, (As One). 3. - Stool(s) Riding on Paper. 4. - Stool(s) Beneath Paper. 5. - Stools Combined With, Leading and Trailing Paper, (As One Solid). 6. - Diarrhoea Encompassing Solid. 0. - NOT APPROPRIATE.

Each Observed 'On-Site' Solid was allotted a Classification Number, in Accordance With the Above, of the Form:- A/B/C/D/E/F. For Example 2/7/15/0/3/0 = a 150 mm. Long 'Thick' and 'Flat' Toilet/Tissue-Paper Solid.

FIGURE 8/13. - SOLID IDENTIFICATION CODE, - FOR LIVE WASTE LOADS.

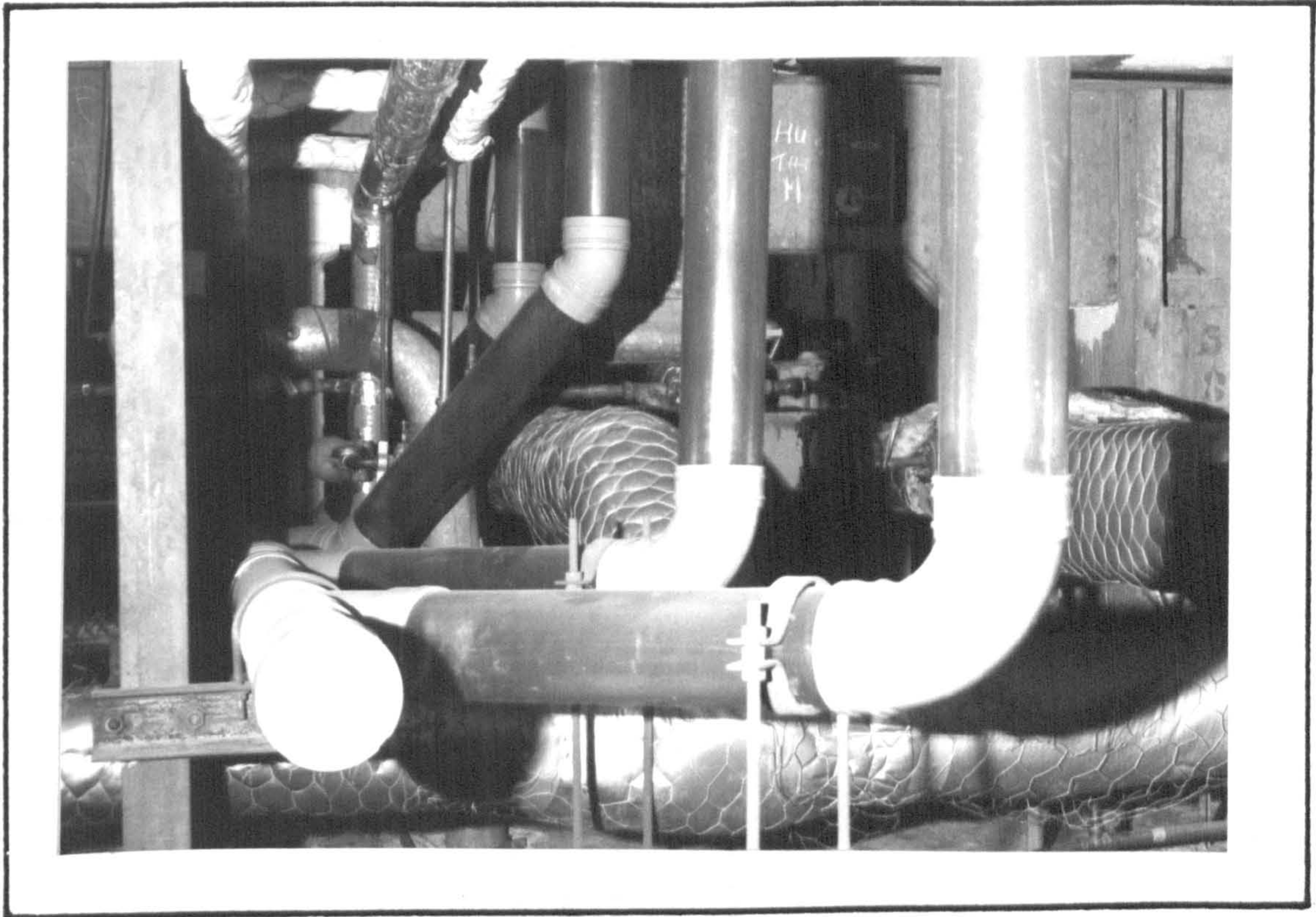

FIGURE 9/1. - Installed U.P.V.C. Service to Nurses' Education Department.

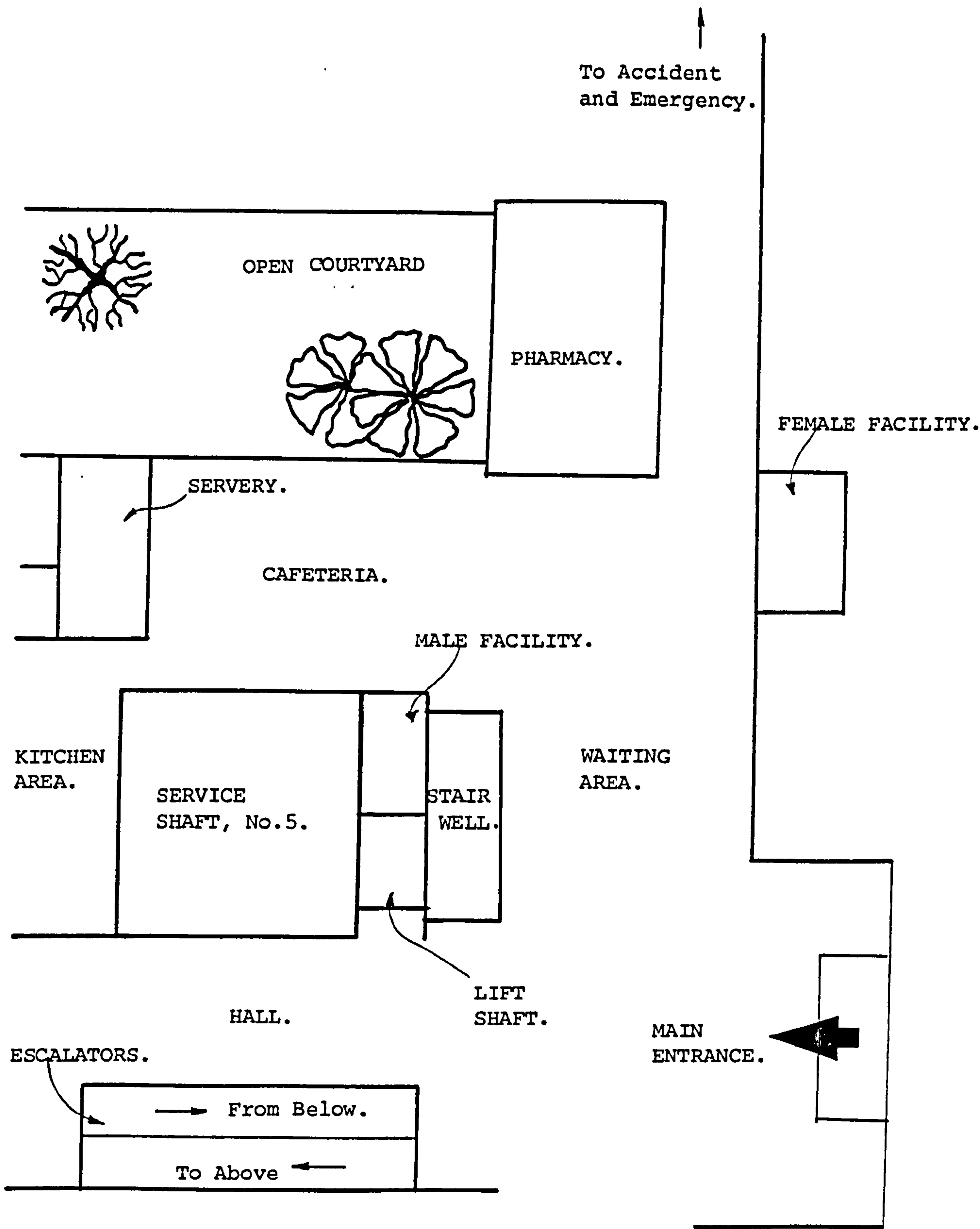

FIGURE 9/2. - Plan of Cafeteria / Circulatory Area, as Serviced by the Monitored Facilities.

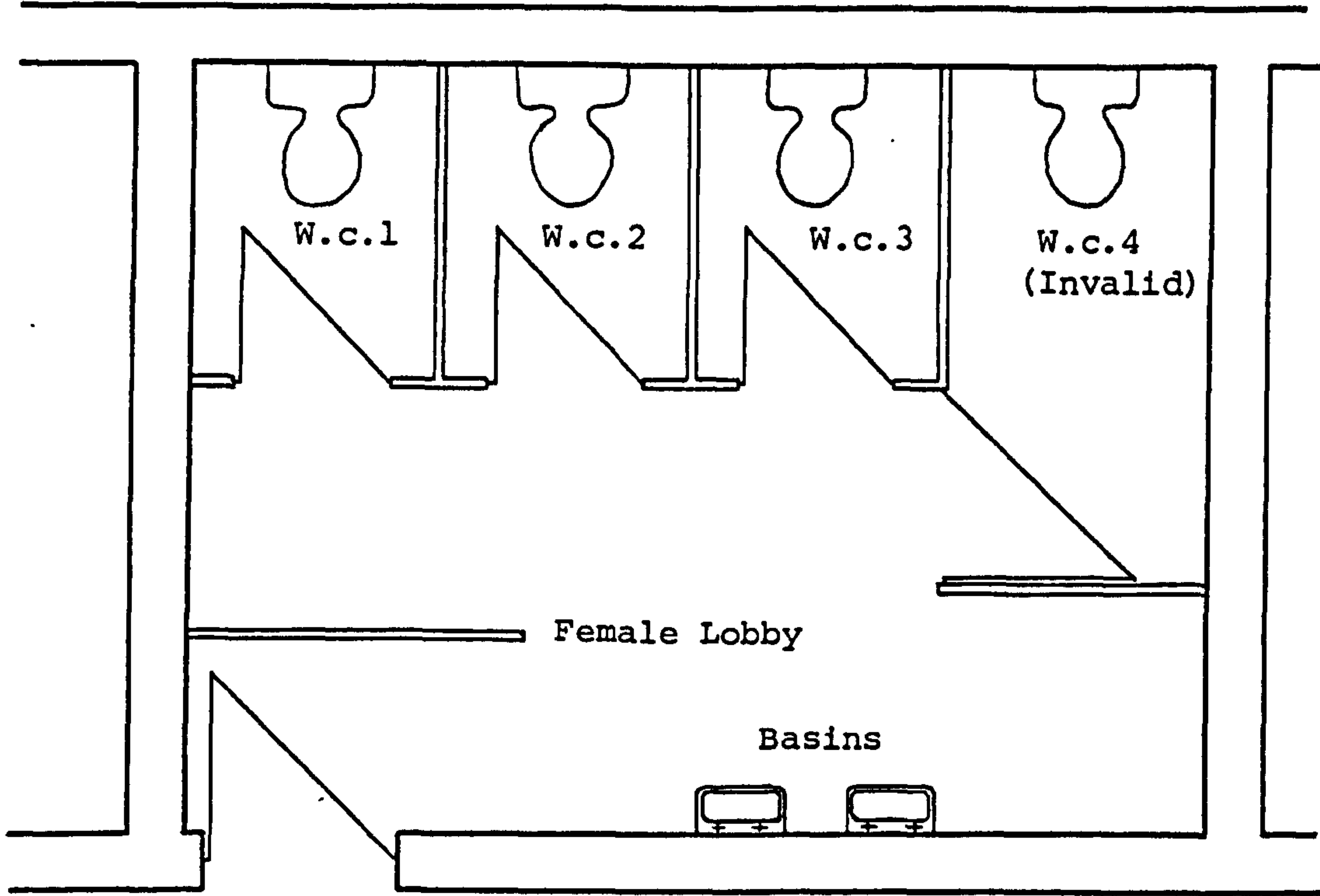

FIGURE 9/3. - Plan of Female Facility and Installed Services.

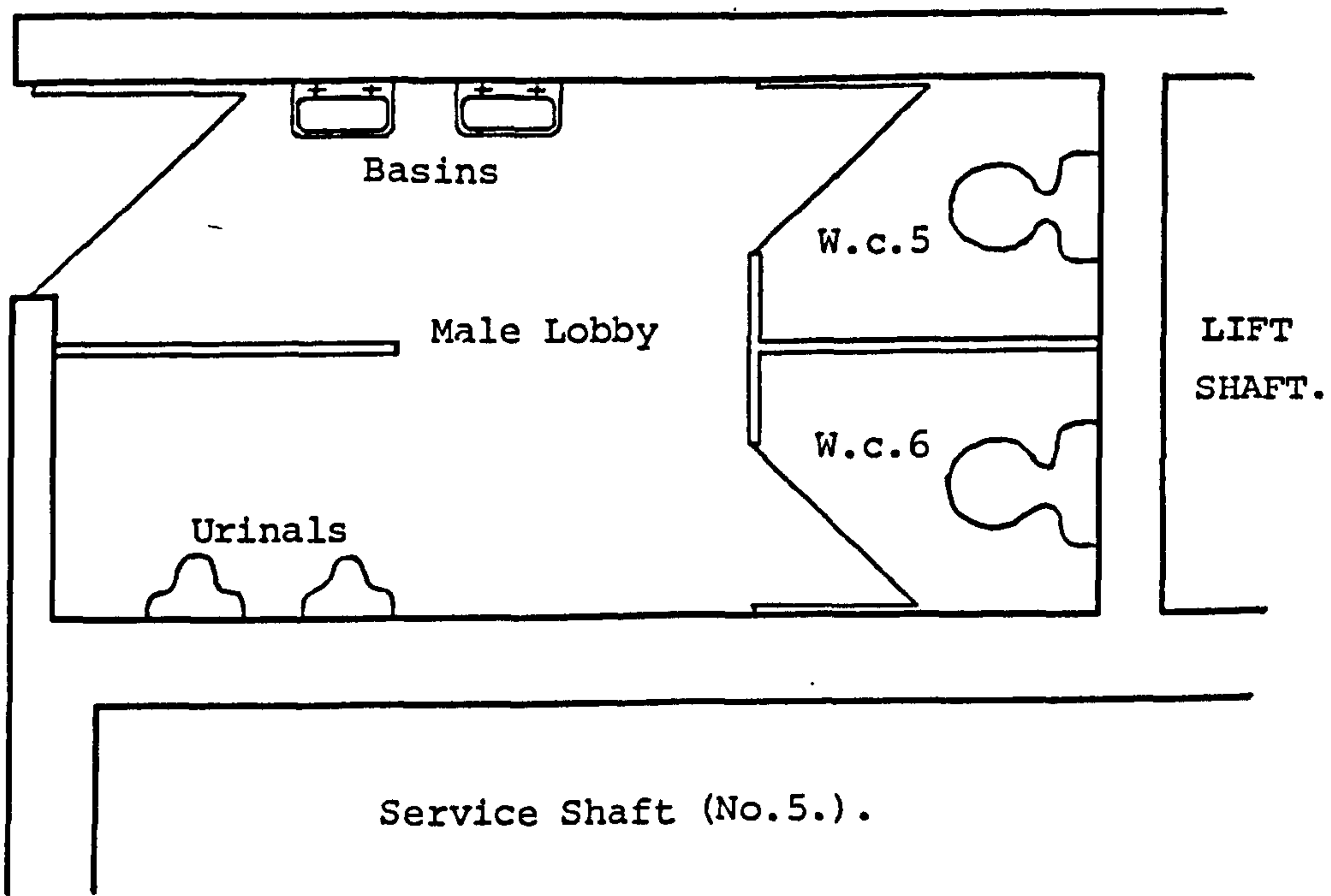

FIGURE 9/4. Plan of Male Facility and Installed Services.

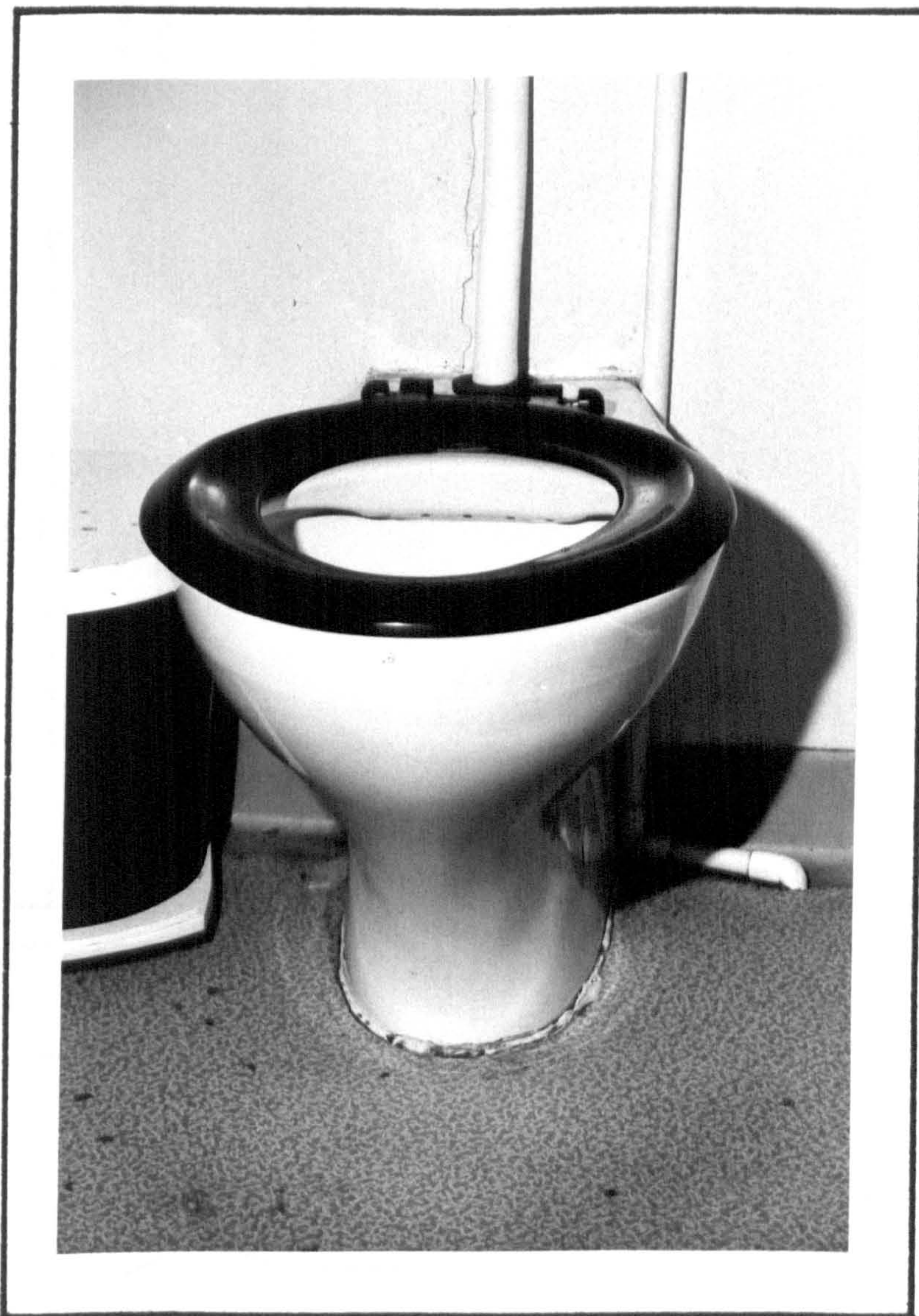

FIGURE 9/5. - Installed Armitage Shanks V1207,
'Top-Inlet', 'S-trap' W.C. Pan.

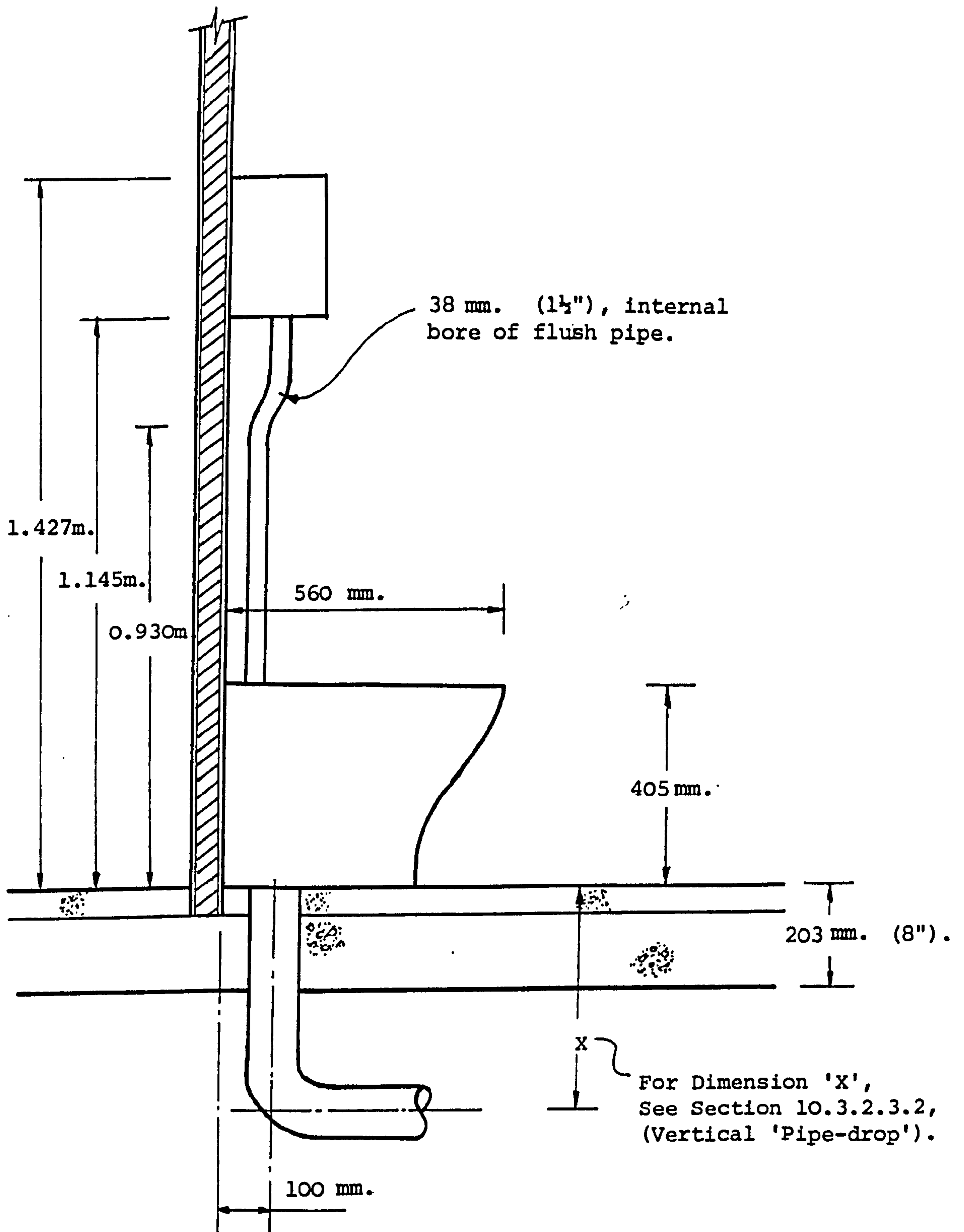

FIGURE 9/6. - W.C./Cistern Configuration, ('On-Site')



FIGURE 9/7. Installed Urinals.

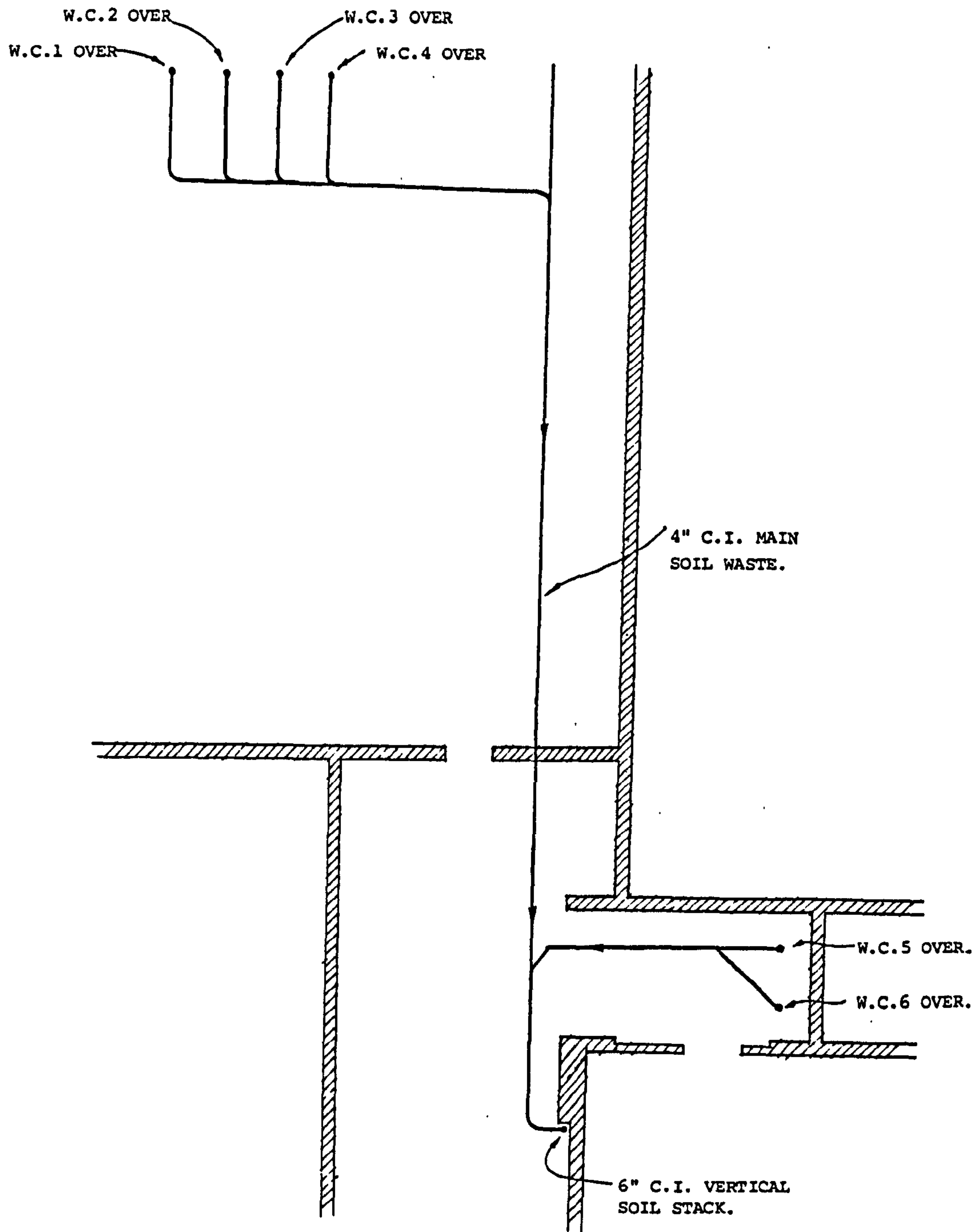

FIGURE 9/8. - Original C.I. Service Pipework,
to Monitored Facilities.

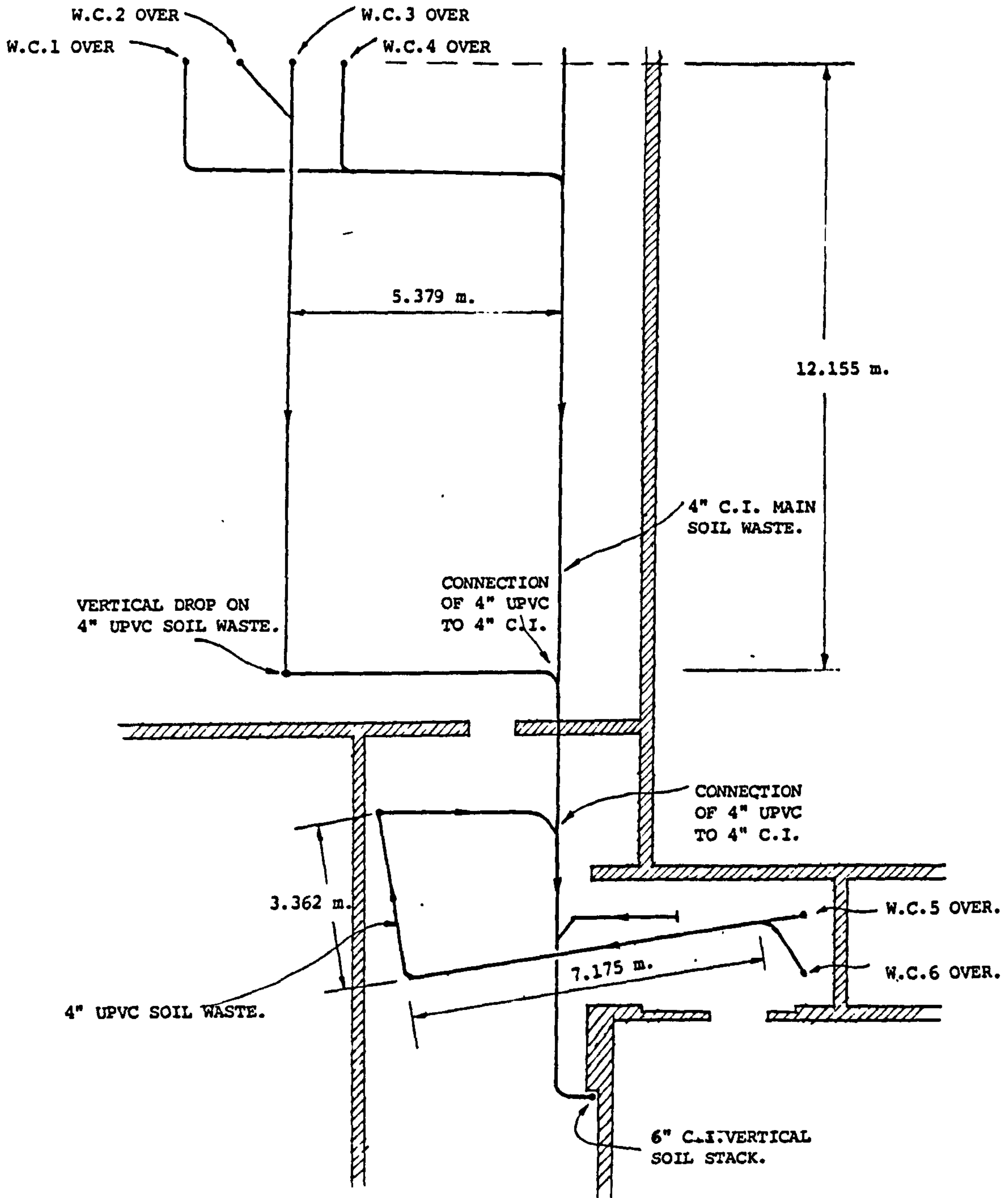
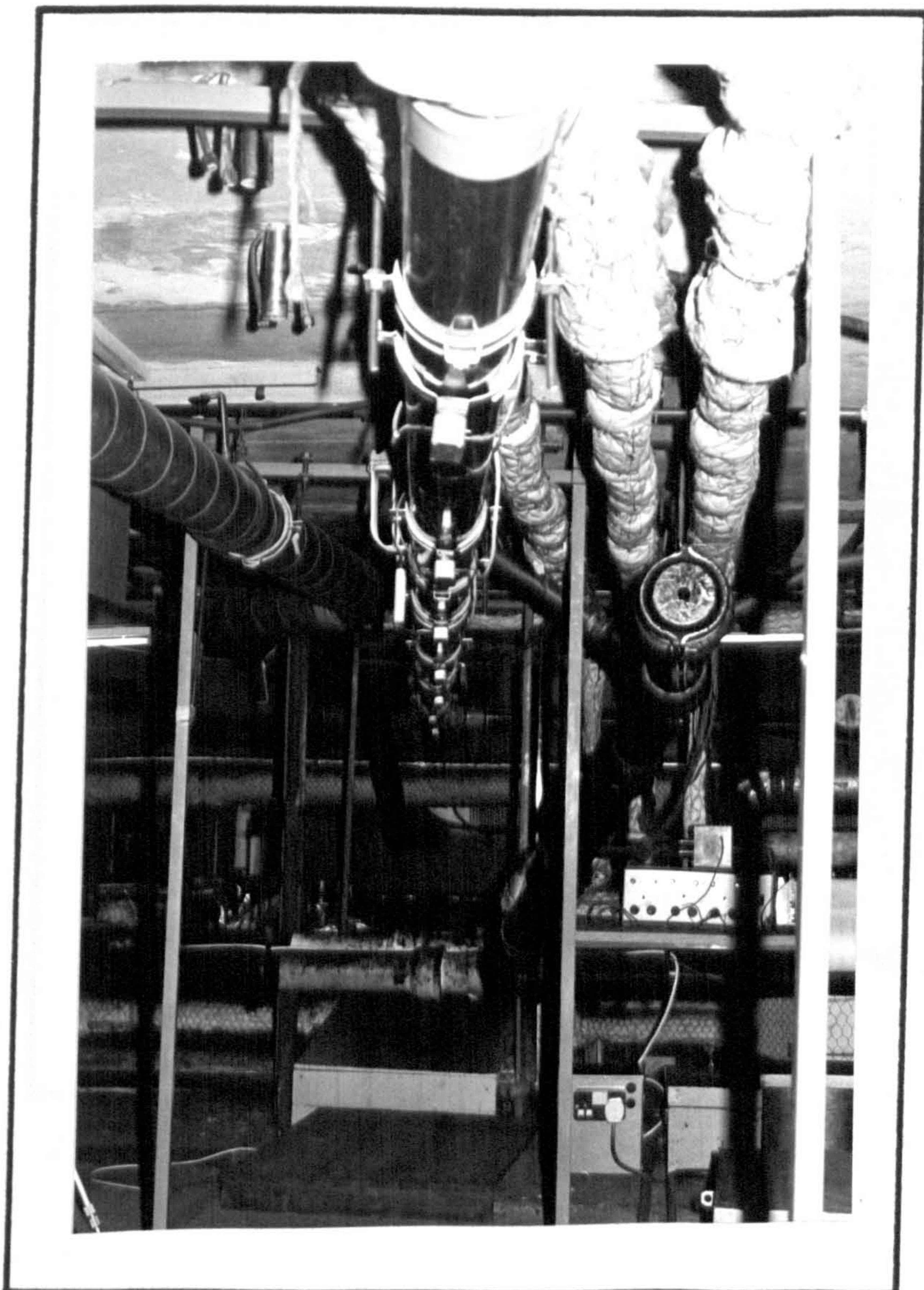
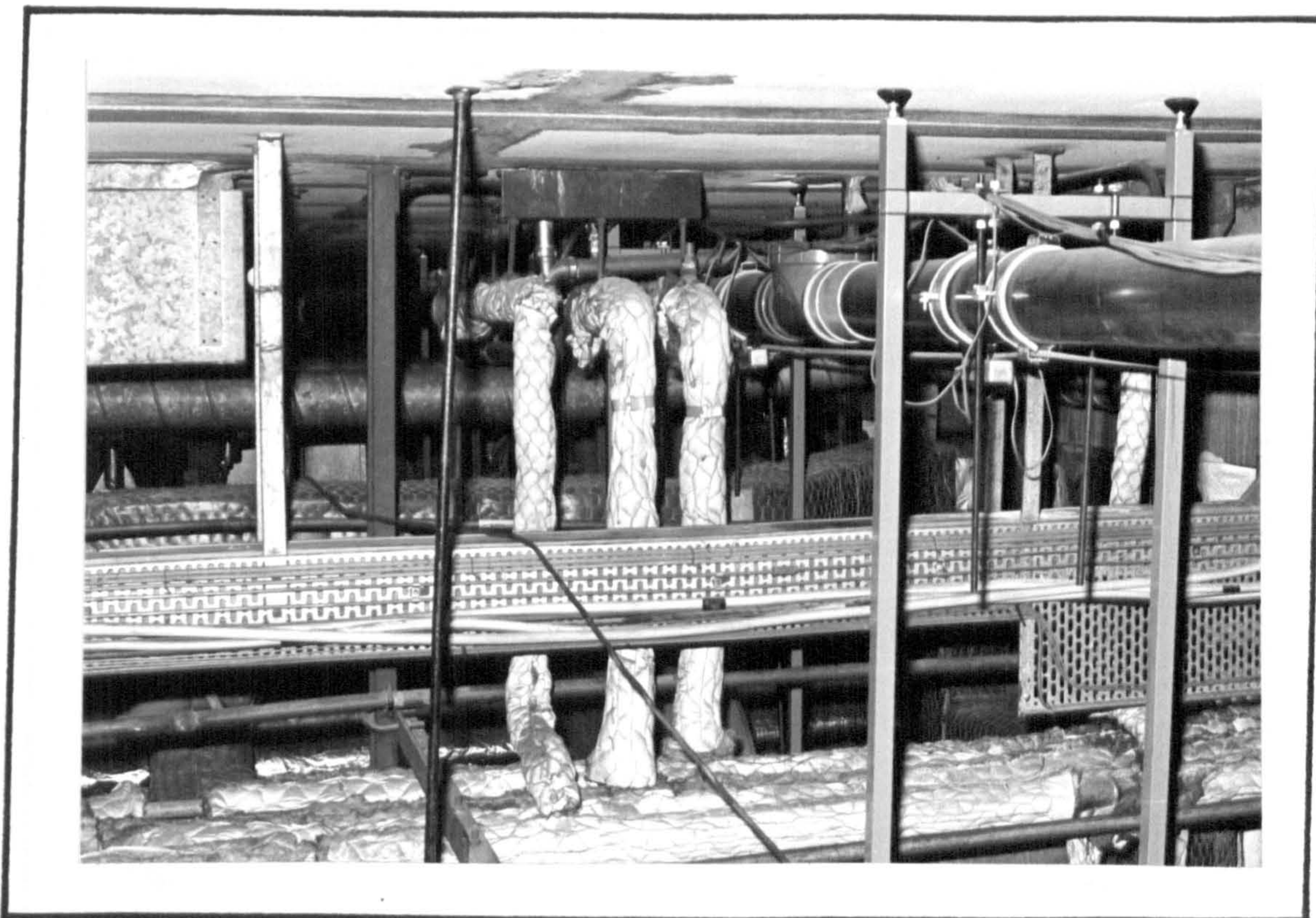

FIGURE 9/9. - Adapted Service Pipework Layout,
to Monitored Facilities.



▲
FIGURE 9/10.
Example of Floor-void
Congestion, - through
which a route had to
be found for the
monitored pipework
to the Female Facility.

◀ FIGURE 9/11.
Original C.I. Service,
to Male Facility,
cut-back to accommodate
U.P.V.C. Service.

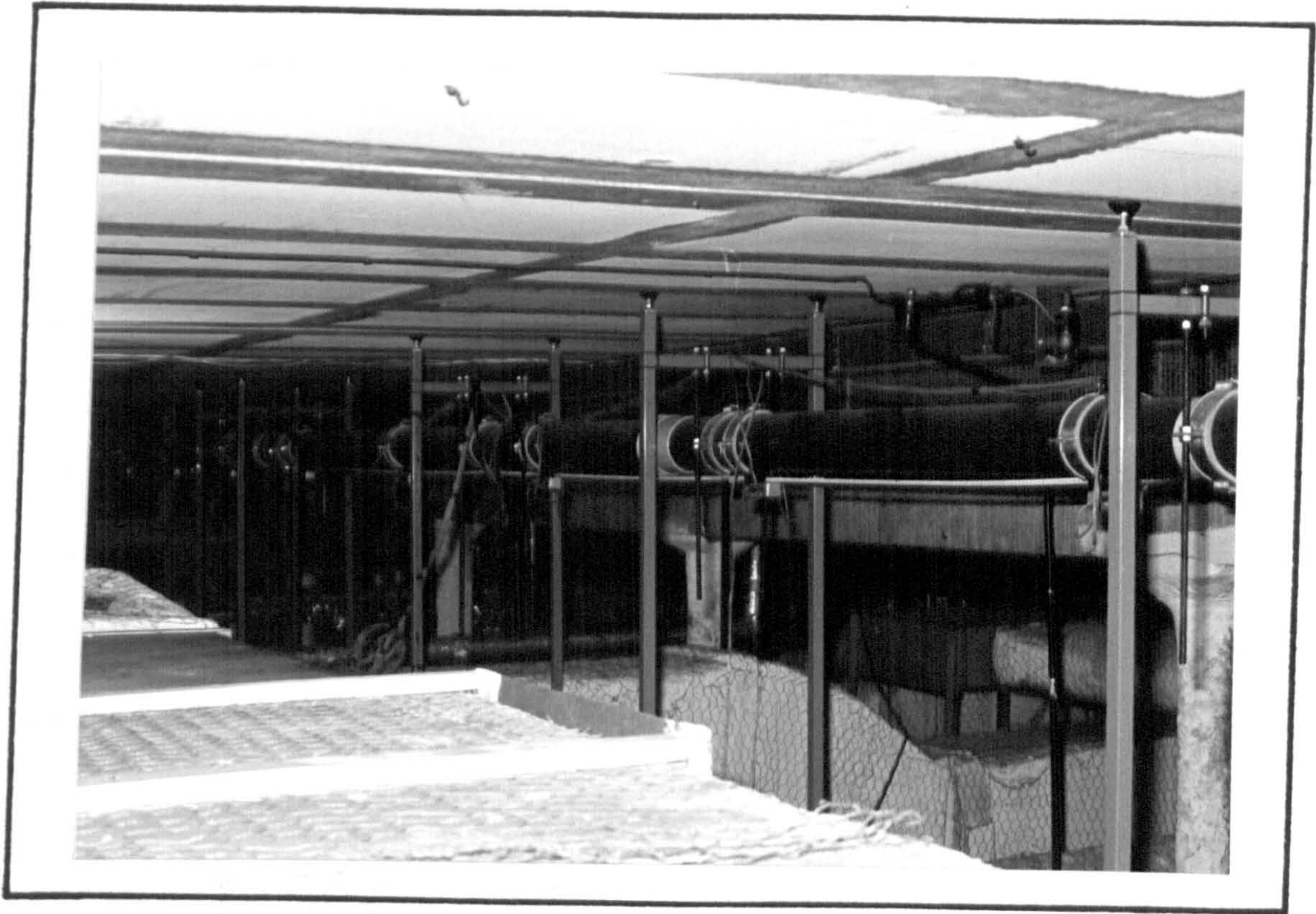

FIGURE 9/12.- General View of Installed U.P.V.C. Service to the Female Facility.



FIGURE 9/13. - General View of Installed U.P.V.C. Service to the Male Facility.

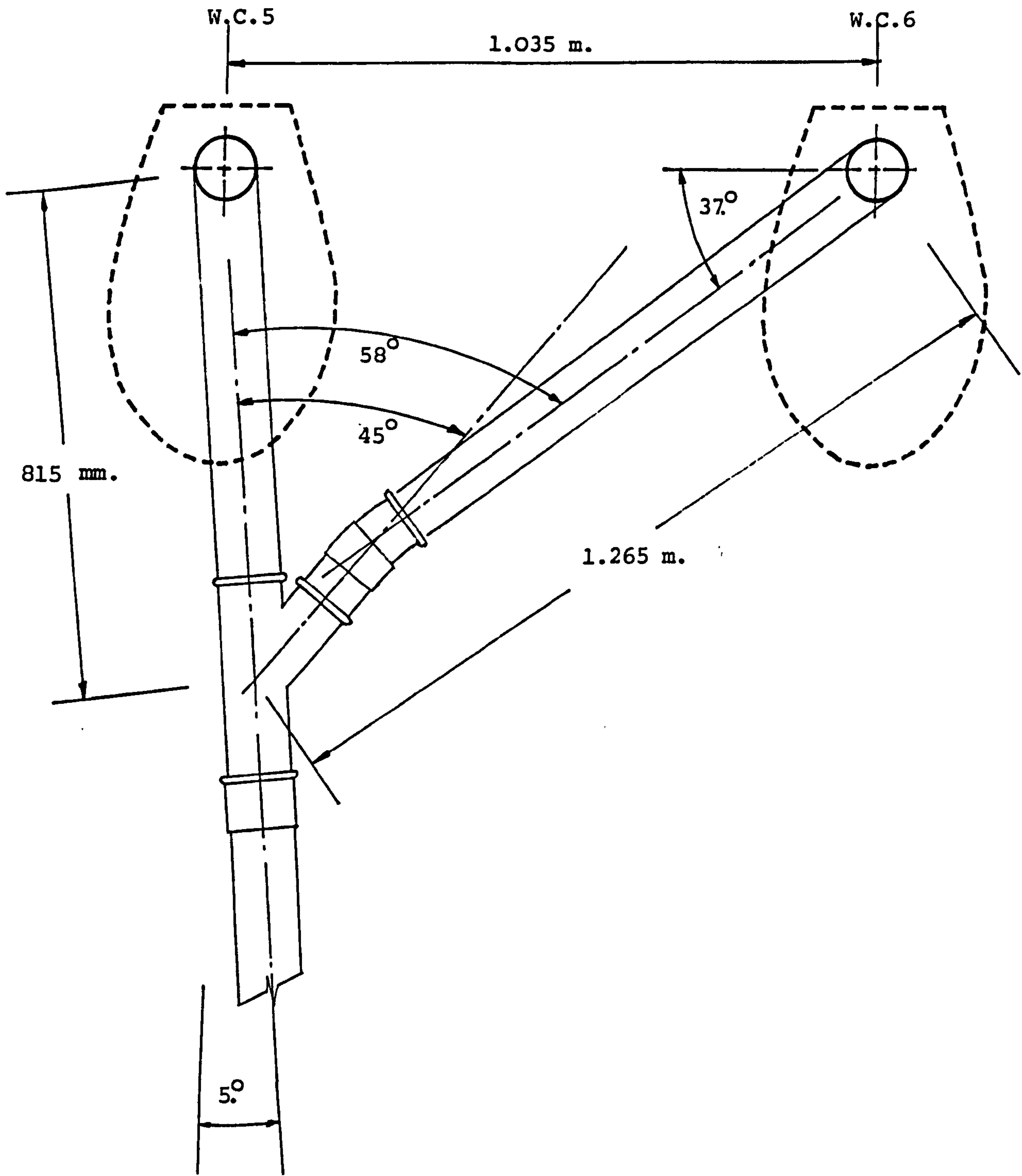

FIGURE 9/14. - 135° U.P.V.C. Junction Arrangement on Male Service System.

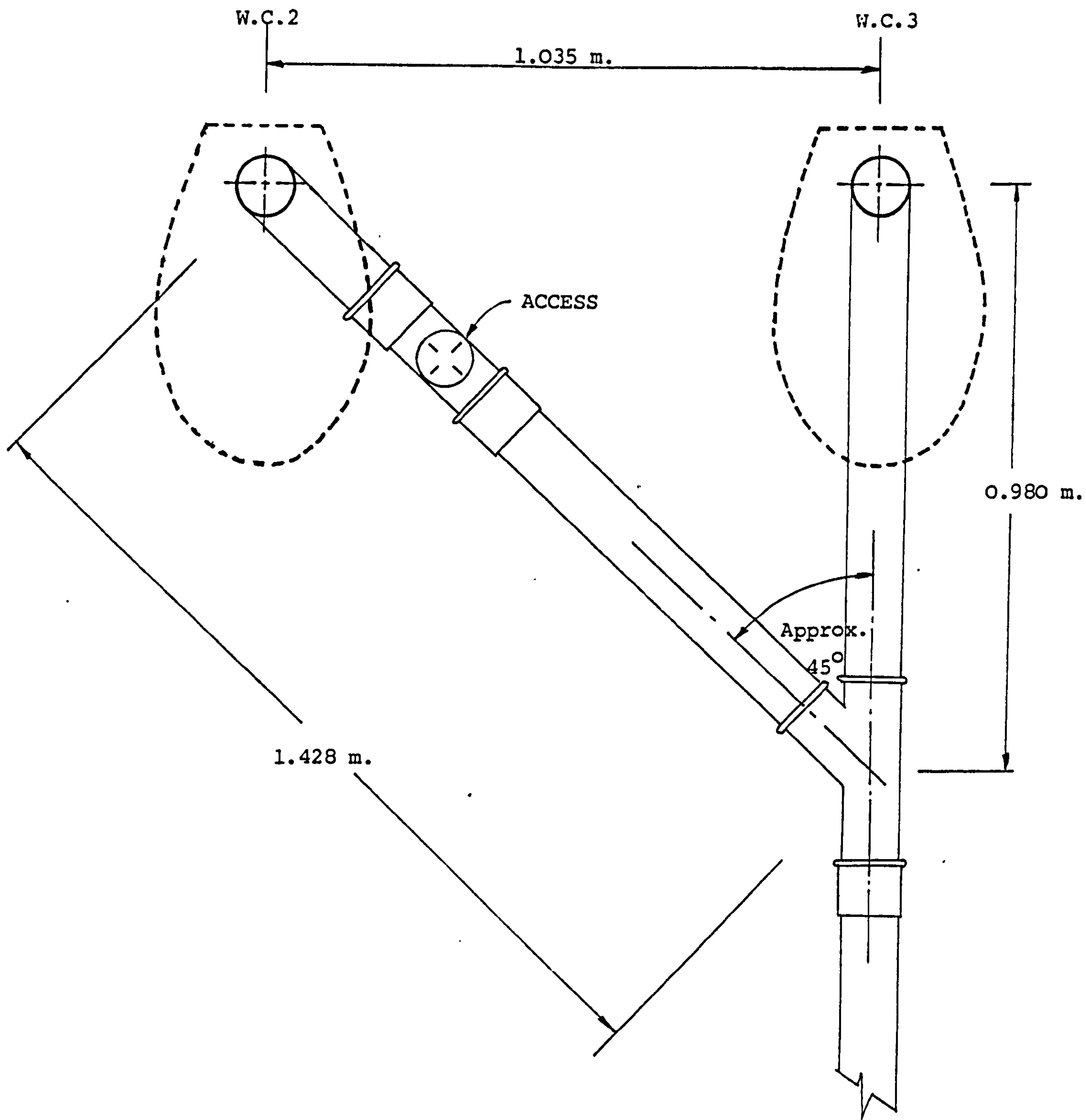
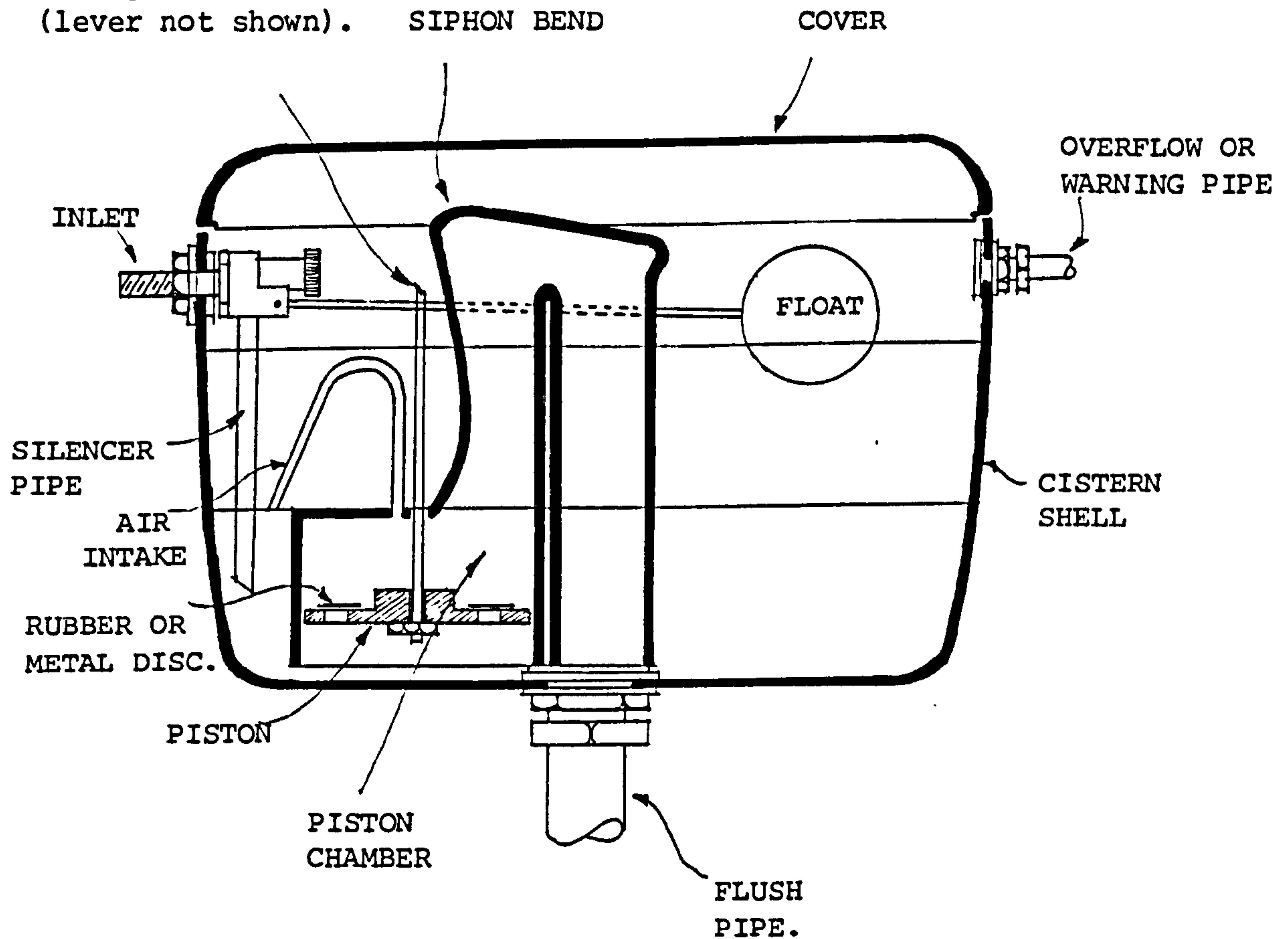

FIGURE 9/15. - 135°. U.P.V.C. Junction Arrangement on Female Service System.

Operating Lever
Attached to this
Linkage.

(lever not shown).



When lever is depressed sharply, the upthrust of the piston lifts water over the siphon bend. As water runs down the flush pipe it takes some air with it. This causes a reduction in air pressure, and starts the siphonic action.

DUAL OPERATION - flush, and release handle, allows 4.5 litre flush (air drawn through 'AIR INTAKE'), flush, and hold handle down, allows full 9.1 litre flush ('AIR INTAKE' sealed by 'PISTON').

FIGURE 9/16. Operating Mechanism of 'Dual-flush' Cistern.

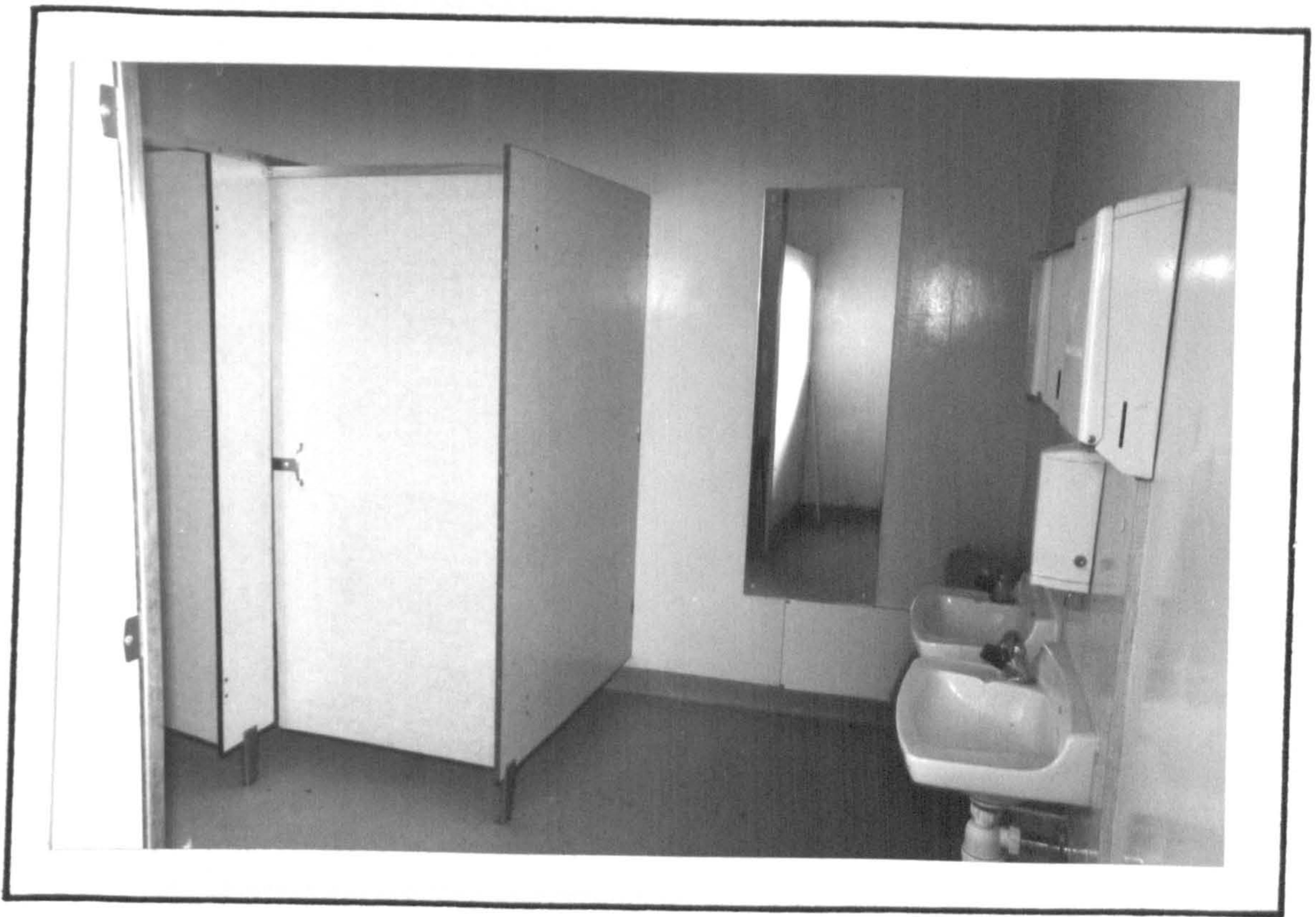

FIGURE 9/17. - General View of Female Facility.

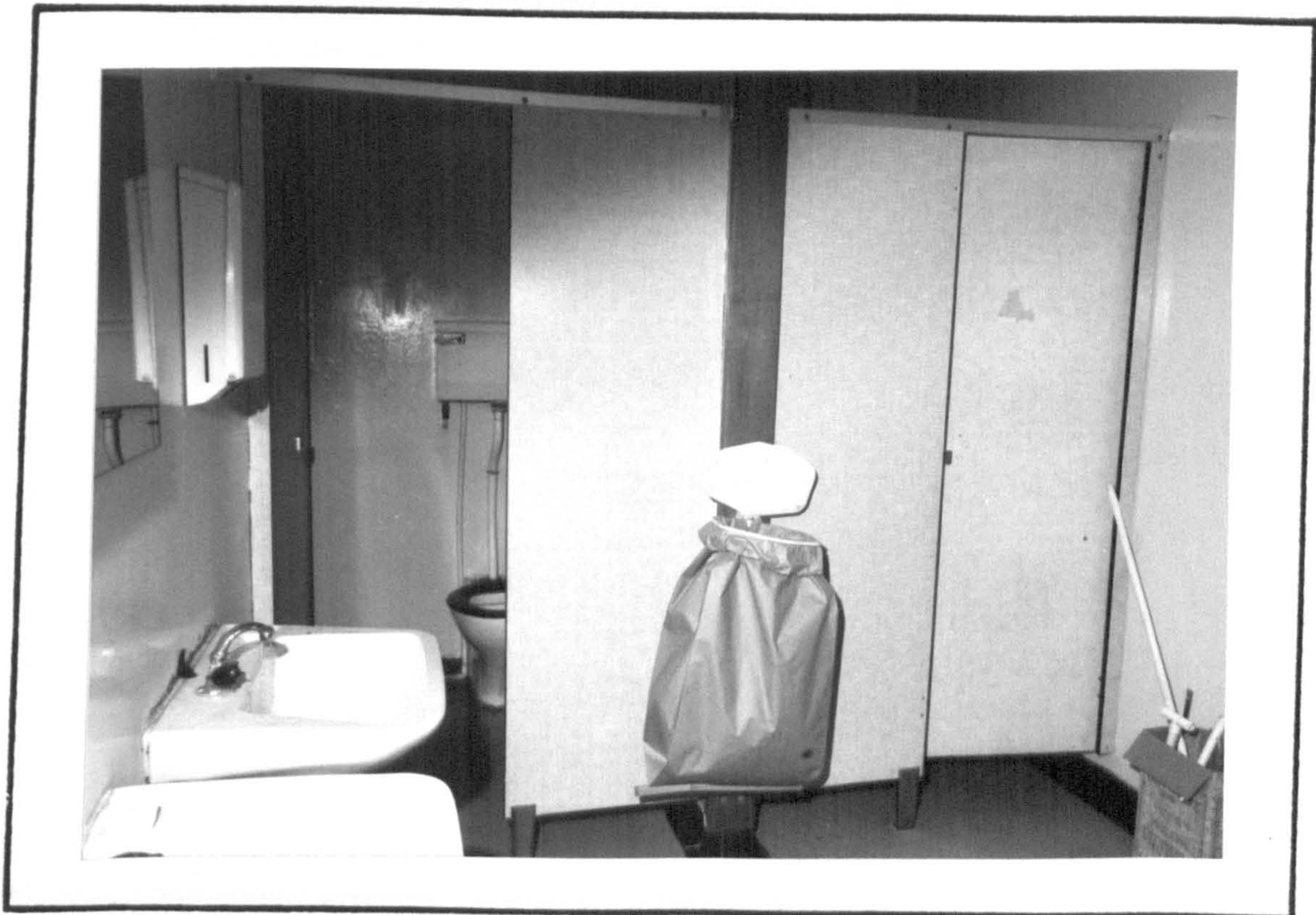

FIGURE 9/18. - General View of Male Facility.



FIGURE 9/19. - General View of the 'Cafeteria' Section of the Area Serviced by the Monitored Facilities.



FIGURE 9/20. - General View of the 'Circulatory' Section of the Area Serviced by the Monitored Facilities.

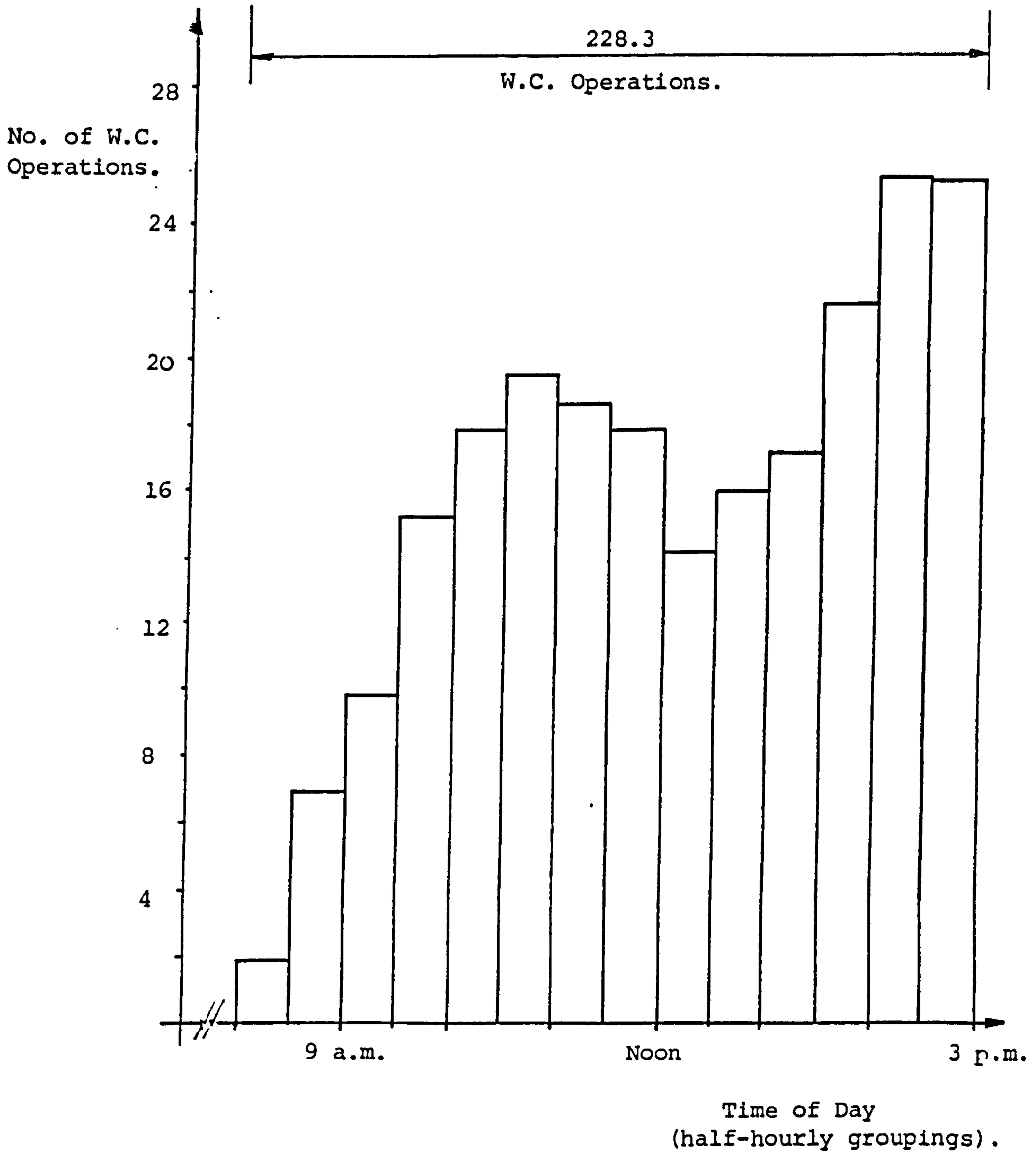

FIGURE 10/1. - Total W.C. usage per mean weekday, 8 a.m. to 3 p.m., at the Female Facility (All four appliances).

Time Period	W.C. 1						W.C. 2					
	Mon.	Tues.	Wed.	Thur.	Fri.	Mean	Mon.	Tues.	Wed.	Thur.	Fri.	Mean
8.-8.30 a.m.	0.33	0.44	0.50	0.50	0.	0.35	0.66	0.11	1.00	0.	0.33	0.42
8.30 -9.a.m.	1.40	1.00	3.33	1.33	0.33	1.48	2.00	1.22	0.67	1.67	1.33	1.38
9.-9.30 a.m.	1.60	2.67	1.33	2.67	2.33	2.12	3.20	2.67	2.00	2.33	0.67	2.17
9.30 - 10.	3.60	2.89	5.00	4.00	2.67	3.63	3.80	2.89	4.67	5.00	3.67	4.01
10.-10.30	3.00	5.00	2.67	4.67	3.00	3.67	4.80	2.77	4.67	4.67	4.50	4.28
10.30 -11.	6.80	5.22	5.00	4.67	2.50	4.84	4.00	4.56	3.67	3.33	4.00	3.91
11.-11.30	5.80	5.78	2.33	4.67	3.00	4.32	4.40	4.78	4.67	4.33	6.00	4.84
11.30 -12.	3.40	4.56	2.67	5.33	3.20	3.83	4.00	5.00	4.00	4.67	4.40	4.41
12.-12.30	2.75	3.33	2.33	4.25	2.60	3.05	2.75	4.22	2.33	4.50	3.40	3.44
12.30 -1.	3.25	3.56	3.33	4.25	4.60	3.80	3.00	4.11	3.33	5.75	2.40	3.72
1.-1.30 p.m.	4.75	6.11	5.67	4.75	2.80	4.82	4.00	6.00	3.67	4.75	4.00	4.48
1.30 -2.p.m.	4.75	6.33	3.33	6.25	3.25	4.78	6.00	7.67	5.67	5.25	4.25	5.77
2.-2.30 p.m.	4.25	6.71	4.50	5.75	4.50	5.14	6.00	9.43	6.50	7.25	4.50	6.74
2.30 -3.p.m.	5.50	6.50	4.67	8.50	5.00	6.03	6.25	7.00	6.67	8.00	5.00	6.58
TOTALS	51.18	60.10	46.66	61.59	39.78	51.86	54.86	62.43	53.52	61.50	48.45	56.15

Time Period	W.C. 3						W.C. 4					
	Mon.	Tues.	Wed.	Thur.	Fri.	Mean	Mon.	Tues.	Wed.	Thur.	Fri.	Mean
8.-8.30 a.m.	0.33	0.44	1.00	0.	0.	0.35	1.00	0.78	1.00	0.50	0.33	0.72
8.30 -9 a.m.	1.20	1.22	4.00	2.00	2.00	2.08	2.20	1.22	2.33	2.00	1.33	1.82
9.-9.30 a.m.	3.00	3.00	2.33	2.00	2.00	2.47	3.40	3.00	2.67	3.67	2.00	2.95
9.30 - 10.	3.20	3.11	6.33	5.50	3.67	4.36	3.00	2.11	4.67	4.00	3.00	3.36
10.-10.30	4.80	5.00	9.33	4.00	4.50	5.53	5.60	4.67	4.67	2.33	4.00	4.25
10.30 - 11.	6.00	6.22	7.00	6.00	3.75	5.79	4.60	4.44	7.00	4.00	3.50	4.71
11.- 11.30	6.00	6.00	4.33	3.67	6.25	5.25	4.60	5.11	4.00	3.33	3.50	4.11
11.30 - 12.	4.20	6.67	4.67	4.00	5.60	5.03	5.00	4.78	4.00	4.33	4.00	4.42
12.- 12.30	4.50	5.00	3.33	4.25	4.00	4.22	3.75	4.00	4.00	3.25	2.20	3.44
12.30 -1.	4.75	5.22	4.00	3.25	5.60	4.56	3.00	3.22	4.67	3.25	5.20	3.87
1.-1.30 p.m.	6.00	5.67	3.33	4.75	4.40	4.83	6.25	4.00	6.67	3.25	4.60	4.95
1.30 -2.p.m.	7.00	8.89	9.00	7.00	5.50	7.48	2.75	4.56	3.00	4.00	3.50	3.56
2.-2.30 p.m.	8.50	9.71	7.00	8.00	8.00	8.24	6.00	4.71	5.50	6.00	4.00	5.24
2.30 -3.p.m.	7.50	6.50	7.67	10.00	6.00	7.53	5.00	5.00	4.67	4.00	7.00	5.13
TOTALS	66.98	72.65	73.32	64.42	61.27	67.73	56.15	51.60	58.85	47.91	48.16	52.53

FIGURE 10/2. - Mean Weekday Usage, Per Individual Female Facility W.C. Pan.

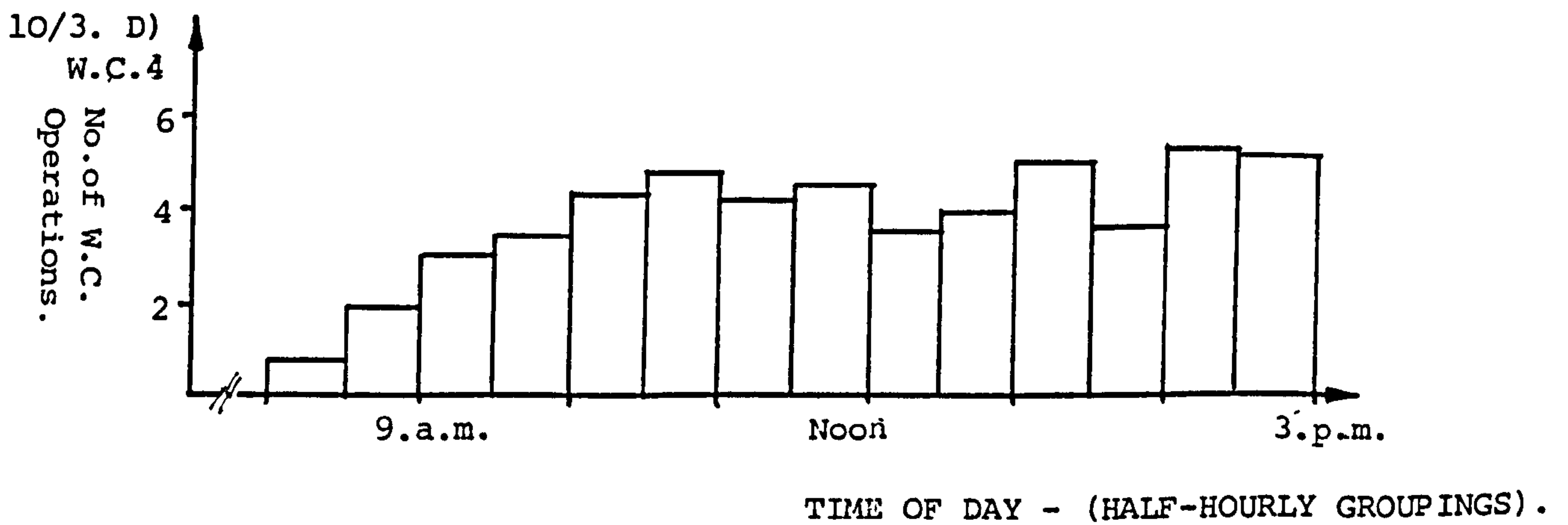
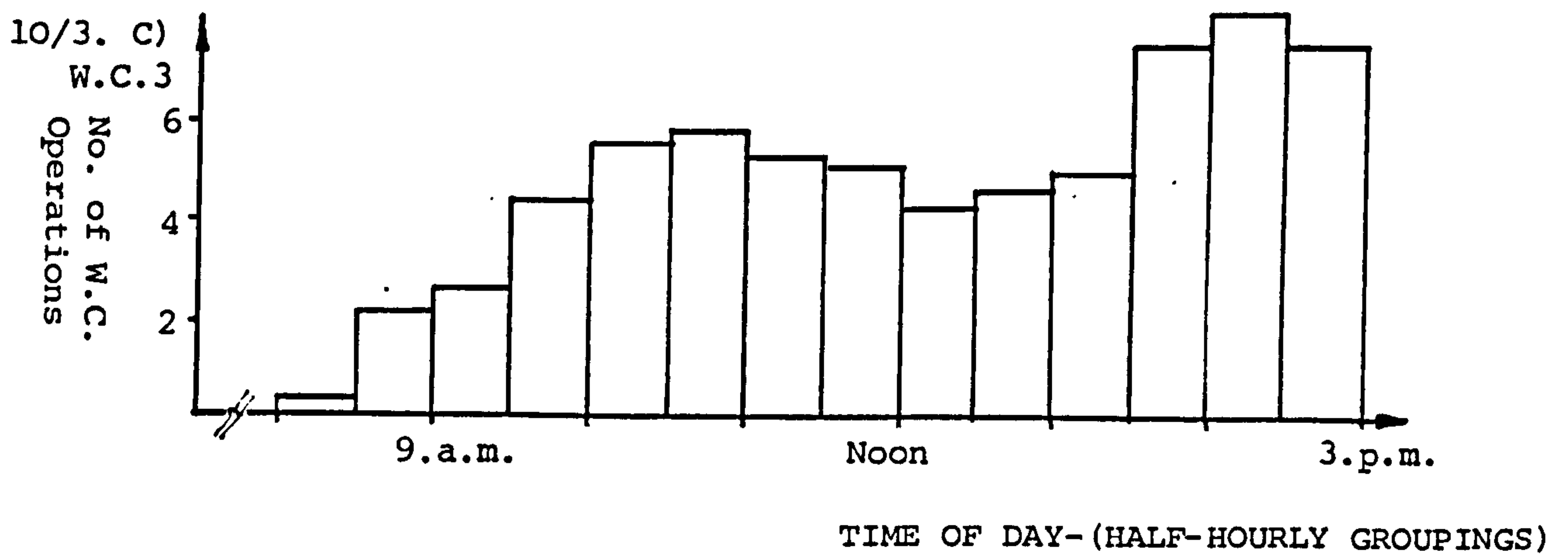
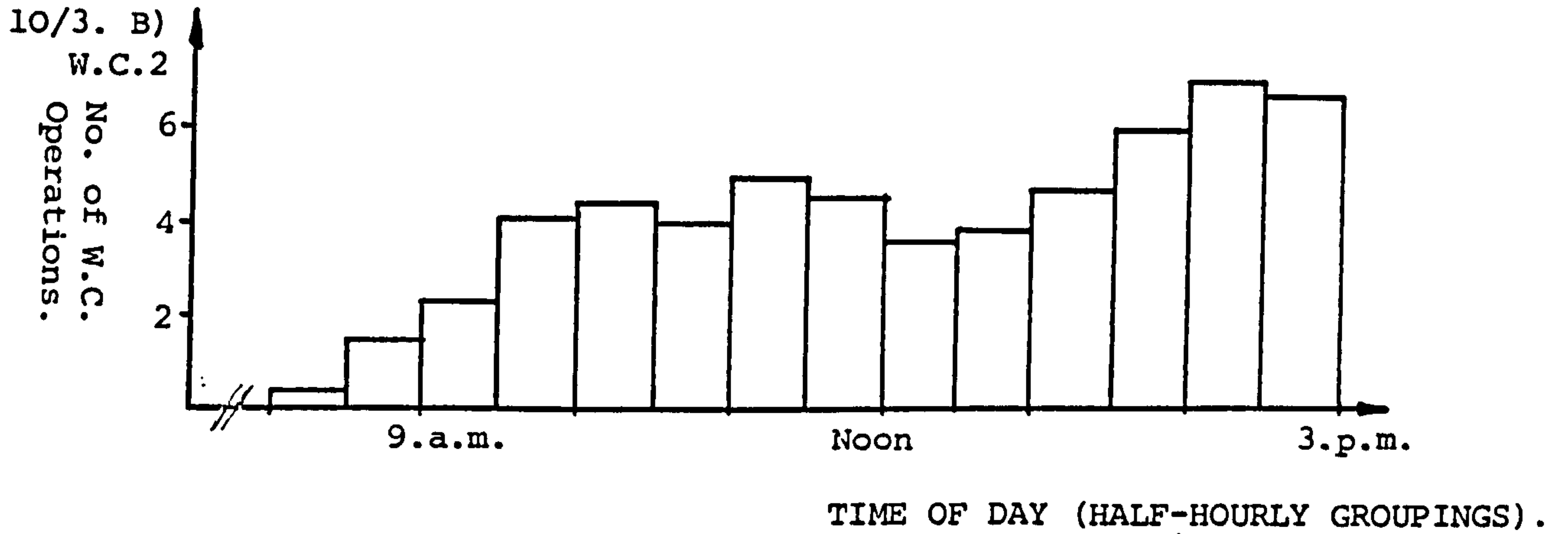
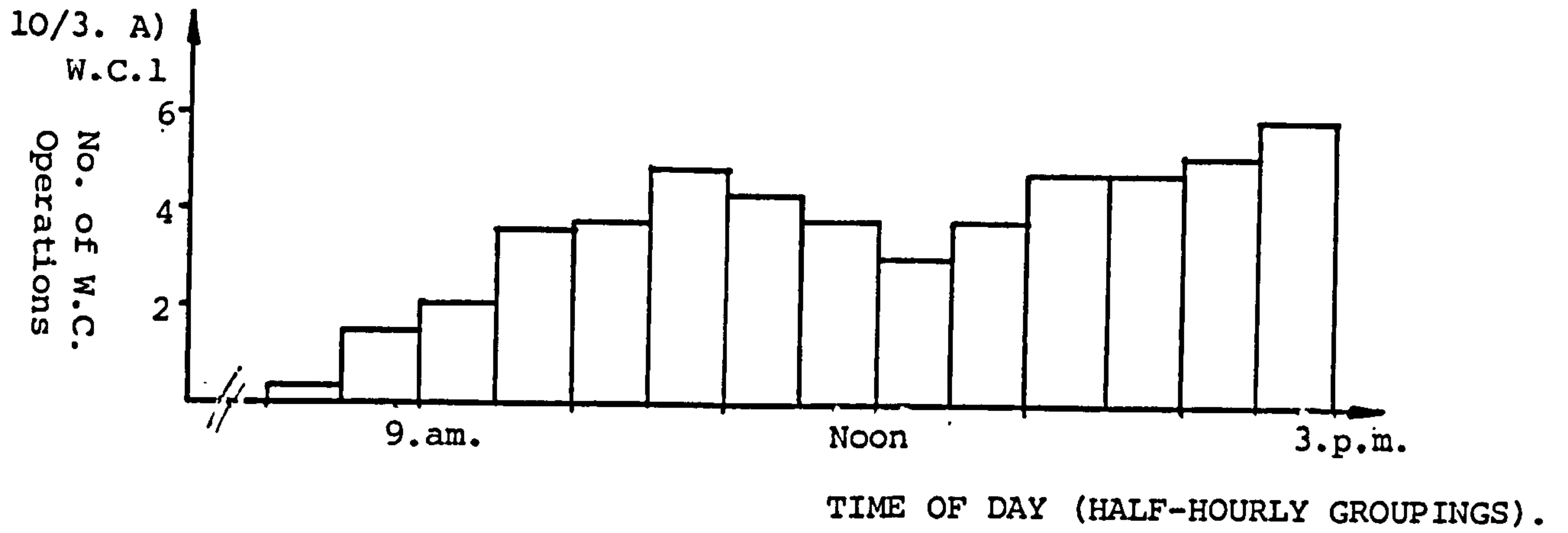

FIGURE 10/3. - Graphical Presentation of Mean Weekday Usage, Per Individual Female Facility W.C. Pan.

No. of W.C. Ops.	Over a 26 Week Period (around the clock).	Average Mon - Fri inclusive (8 a.m.- 3 p.m. each day)	Average Monday, 8 a.m. - 3 p.m.	Average Tuesday, 8 a.m.- 3 p.m.	Average Wednesday 8 a.m. - 3 p.m.	Average Thursday 8 a.m. - 3 p.m.	Average Friday, 8 a.m.- 3 p.m.
W.C.1	12,835 (22.7%)	259.3 (22.7%)	51.18 (22.3%)	60.10 (24.4%)	46.66 (20.1%)	61.59 (26.2%)	39.78 (20.1%)
W.C.2	14,630 (25.9%)	280.76 (24.6%)	54.86 (23.9%)	62.43 (25.3%)	53.52 (23.0%)	61.50 (26.1%)	48.45 (24.5%)
W.C.3	17,377 (30.7%)	338.64 (29.7%)	66.98 (29.2%)	72.65 (29.4%)	73.32 (31.6%)	64.42 (27.4%)	61.27 (31.0%)
W.C.4	11,697 (20.7%)	262.67 (23%)	56.15 (24.5%)	51.60 (20.9%)	58.85 (25.3%)	47.91 (20.4%)	48.16 (24.4%)
TOTALS	56,593 (100%)	1,141.38 (100%)	229.17 (99.9%)	246.78 (100%)	232.35 (100%)	235.42 (100%)	197.66 (100%)

FIGURE 10/4. - Comparative Overall Usage of Individual Female Facility W.C. Pans.

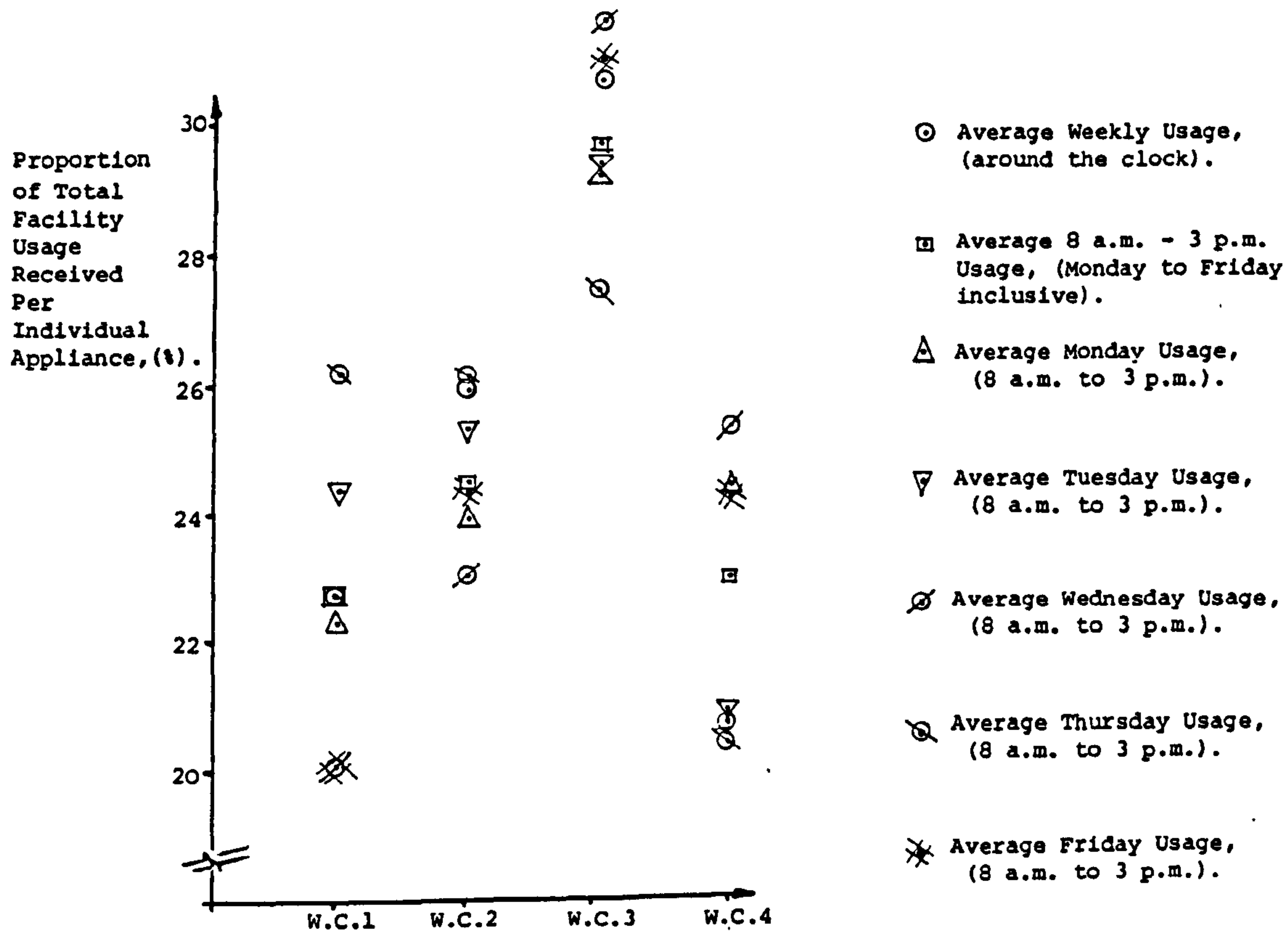
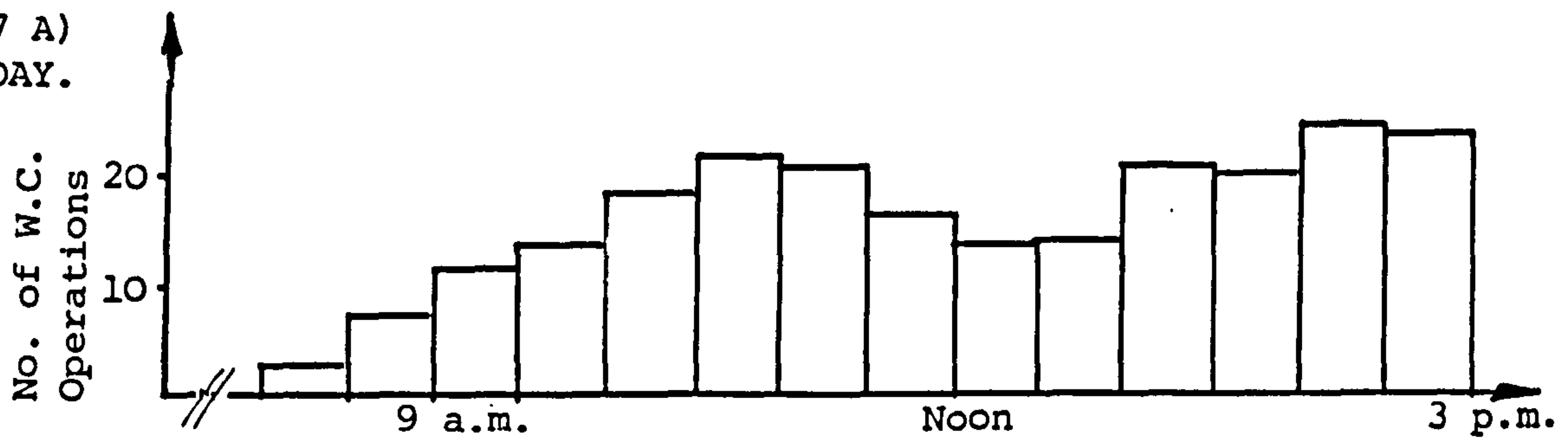

FIGURE 10/5. - Graphical Presentation of Comparative Overall Usage of Individual Female Facility W.C. Pans.

AVERAGE NUMBER OF W.C. OPERATIONS.	MONDAY					TUESDAY					WEDNESDAY					THURSDAY					FRIDAY					
	W.C. 1	W.C. 2	W.C. 3	W.C. 4	TOTAL USAGE	W.C. 1	W.C. 2	W.C. 3	W.C. 4	TOTAL USAGE	W.C. 1	W.C. 2	W.C. 3	W.C. 4	TOTAL USAGE	W.C. 1	W.C. 2	W.C. 3	W.C. 4	TOTAL USAGE	W.C. 1	W.C. 2	W.C. 3	W.C. 4	TOTAL USAGE	
8.00 - 8.30 a.m.	0.33	0.66	0.33	1.00	2.32	0.44	0.11	0.44	0.78	1.77	0.50	1.00	1.00	1.00	3.50	0.50	0.50	0.50	0.50	1.00	0.50	0.33	0.33	0.33	0.33	0.66
8.30 - 9.00 a.m.	1.40	2.00	1.20	2.20	6.80	1.00	1.22	1.22	1.22	4.66	3.33	0.67	4.00	2.33	10.33	1.33	1.67	2.00	2.00	7.00	1.33	1.33	2.00	1.33	4.99	
9.00 - 9.30 a.m.	1.60	3.20	3.00	3.40	11.20	2.67	2.67	3.00	3.00	11.34	1.33	2.00	2.33	2.67	8.33	2.67	2.33	2.00	3.67	10.67	2.33	0.67	2.00	2.00	7.00	
9.30 - 10.00 a.m.	3.60	3.80	3.20	3.00	13.60	2.89	2.89	3.11	2.11	11.00	5.00	4.67	6.33	4.67	20.67	4.00	5.00	5.50	4.00	18.50	2.67	3.67	3.67	3.00	13.01	
10.00 - 10.30 a.m.	3.00	4.80	4.80	5.60	18.20	5.00	2.77	5.00	4.67	17.44	2.67	4.67	9.33	4.67	21.34	4.67	4.67	4.00	4.50	15.67	3.00	4.50	4.50	4.00	16.00	
10.30 - 11.00 a.m.	6.80	4.00	6.00	4.60	21.40	5.22	4.56	6.22	4.44	20.44	5.00	3.67	7.00	7.00	22.67	4.67	3.33	6.00	4.00	18.00	2.50	4.00	3.75	3.50	13.75	
11.00 - 11.30 a.m.	5.80	4.40	6.00	4.60	20.80	5.78	4.78	6.00	5.11	21.67	2.33	4.67	4.33	4.00	15.33	4.67	4.33	3.67	3.33	16.00	3.00	6.00	6.25	3.50	18.75	
11.30 - 12.00 noon.	3.40	4.00	4.20	5.00	16.60	4.56	5.00	6.67	4.78	21.01	2.67	4.00	4.67	4.00	15.34	5.33	4.67	4.00	4.50	18.33	3.20	4.40	5.60	4.00	17.20	
12.00 - 12.30 p.m.	2.75	2.75	4.50	3.75	13.75	3.33	4.22	5.00	4.00	16.55	2.33	2.33	3.33	4.00	11.99	4.25	4.50	4.25	4.00	16.25	2.60	3.40	4.00	2.20	12.20	
12.30 - 1.00 p.m.	3.25	3.00	4.75	3.00	14.00	3.56	4.11	5.22	3.22	16.11	3.33	3.33	4.00	4.67	15.33	4.25	5.75	3.25	3.25	16.50	4.60	2.40	5.67	5.20	17.80	
1.00 - 1.30 p.m.	4.75	4.00	6.00	6.25	21.00	6.11	6.00	5.67	4.00	21.78	5.67	3.67	3.33	6.67	19.34	4.75	4.75	4.75	4.40	17.50	2.80	4.00	4.40	4.60	15.80	
1.30 - 2.00 p.m.	4.75	6.00	7.00	2.75	20.50	6.33	7.67	8.89	4.56	27.45	3.33	5.67	9.00	3.00	21.00	6.25	5.25	7.00	5.50	22.50	3.25	4.25	5.50	3.50	16.50	
2.00 - 2.30 p.m.	4.25	6.00	8.50	6.00	24.75	6.71	9.43	9.71	4.71	30.56	4.50	6.50	7.00	5.50	23.50	5.75	7.25	8.00	8.00	27.00	4.50	4.50	8.00	4.00	21.00	
2.30 - 3.00 p.m.	5.50	6.25	7.50	5.00	24.25	6.50	7.00	6.50	5.00	25.00	4.67	6.67	7.67	4.67	23.68	8.50	8.00	10.00	6.00	30.50	5.00	5.00	6.00	7.00	23.00	
TOTALS	51.18	54.86	66.98	56.15	229.17	60.10	62.43	72.65	51.60	246.78	46.66	53.52	73.32	58.85	232.35	61.59	61.50	64.42	47.91	235.42	89.78	48.45	61.27	48.16	197.66	

FIGURE 10/6. - Average Usage of Female Facility W.C. Pans Per Individual Weekday.

10/7 A)
MONDAY.



10/7 B)
TUESDAY.

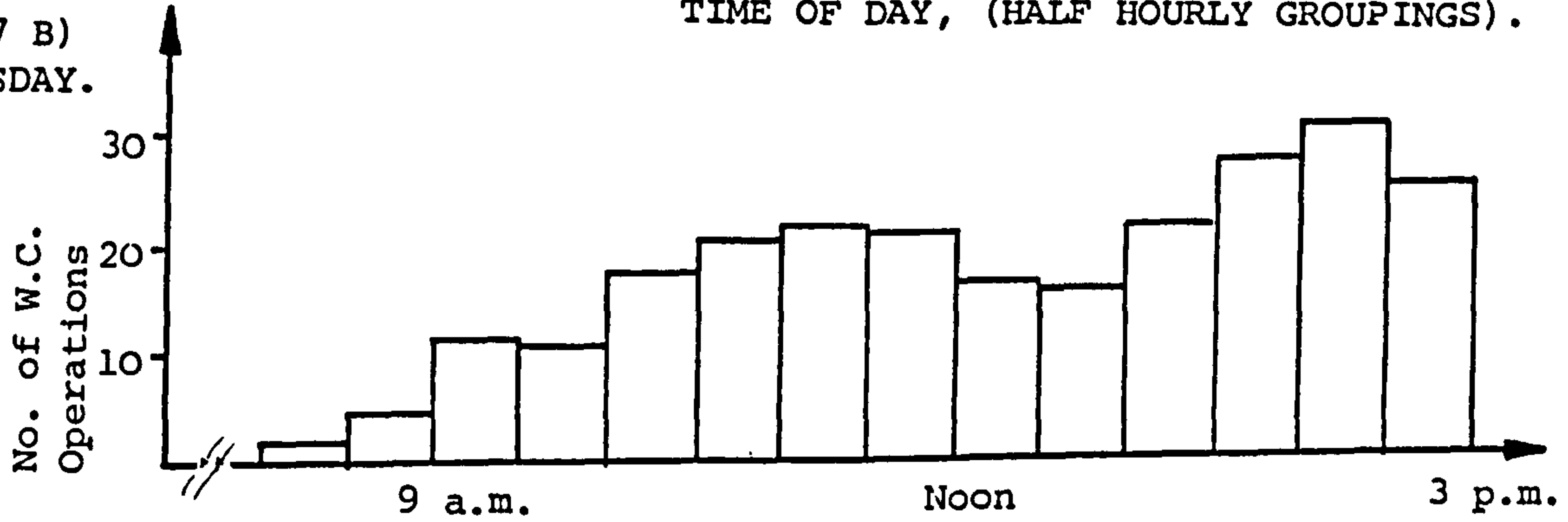

10/7 C)
WEDNESDAY.

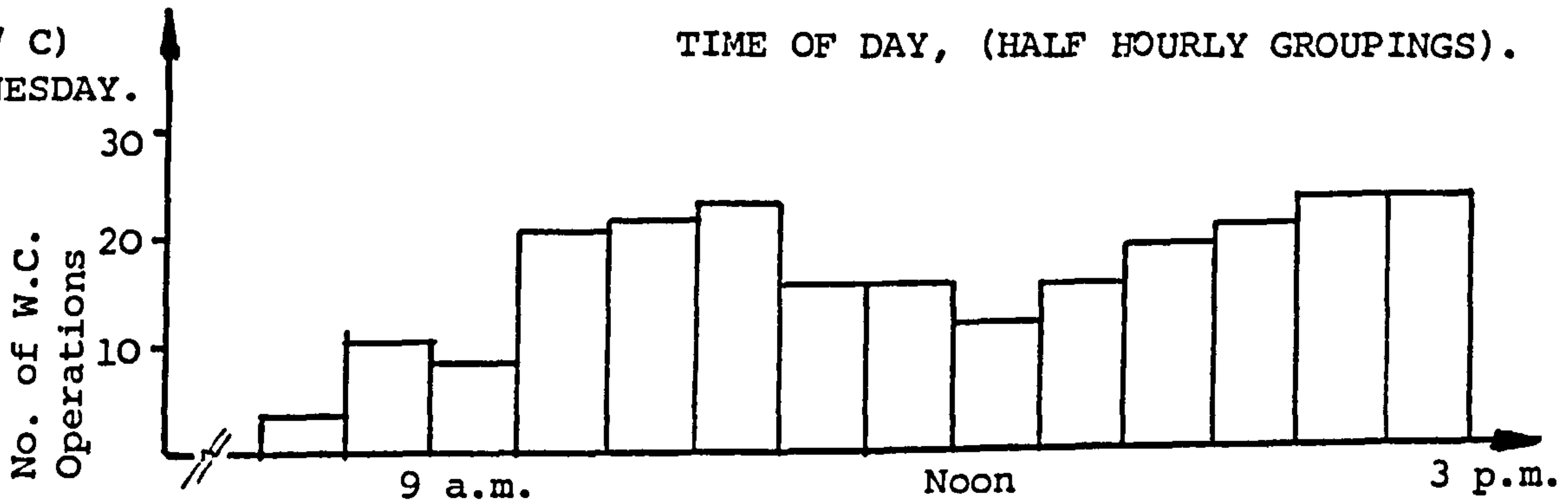

10/7 D)
THURSDAY.

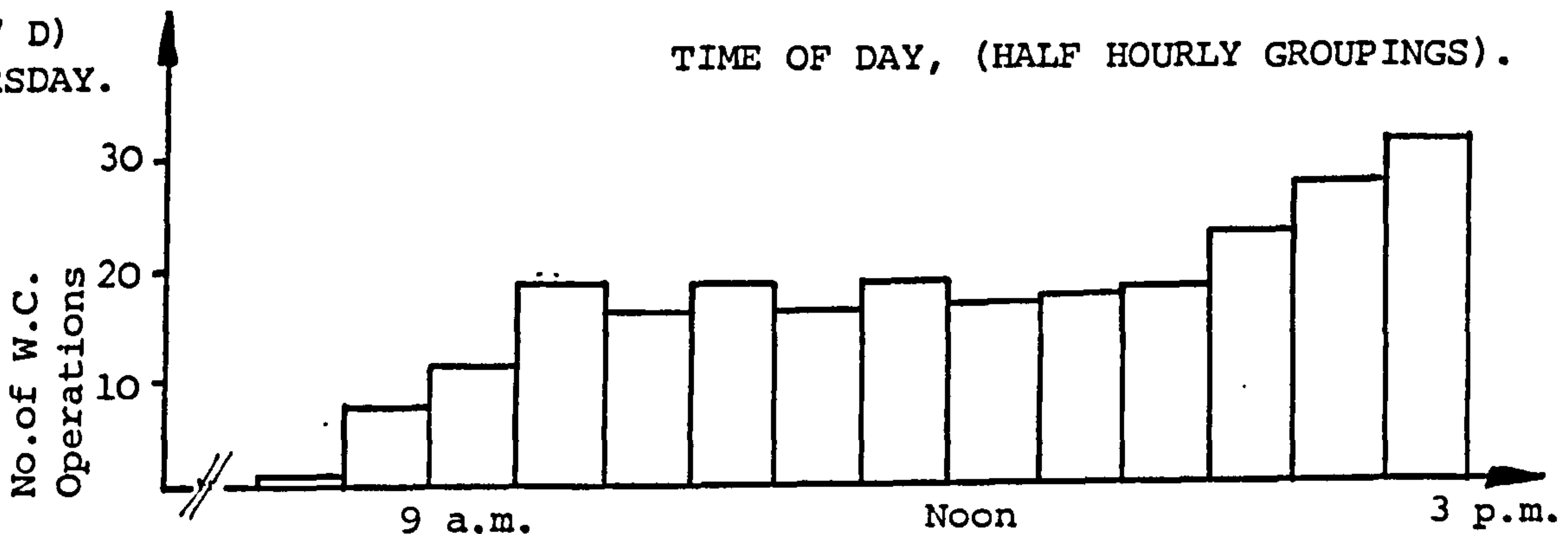

10/7 E)
FRIDAY.

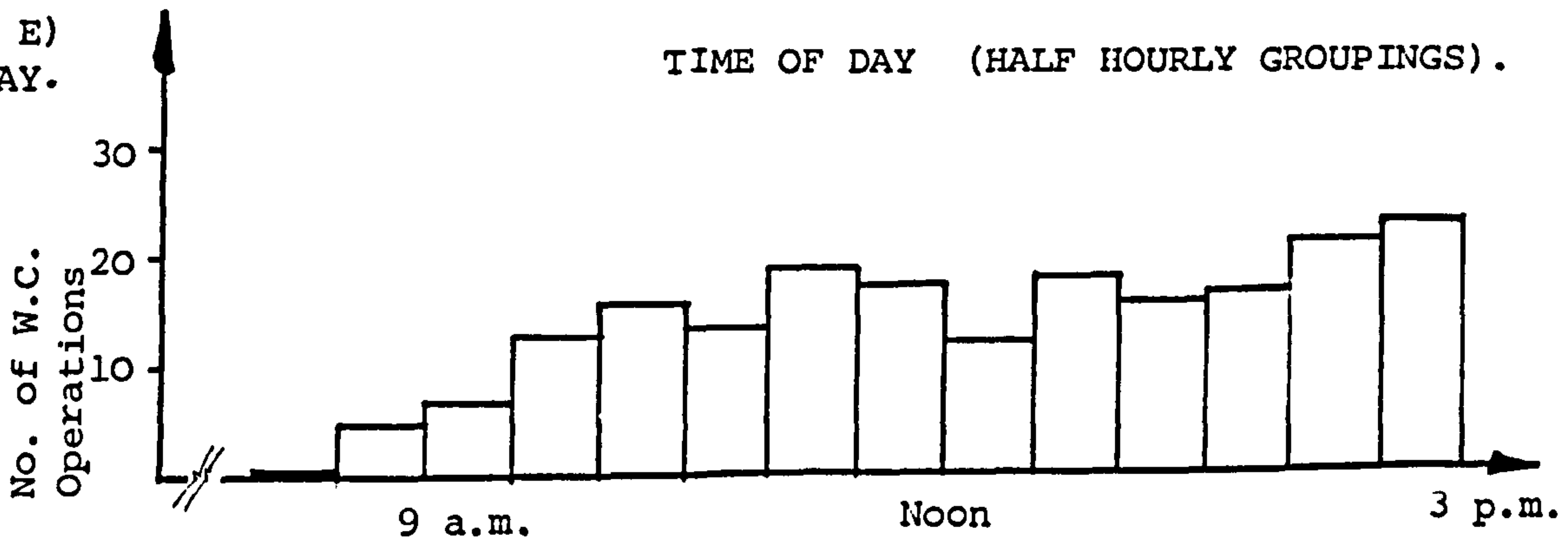

FIGURE 10/7. - Graphical Presentation of Average Usage of Female Facility W.C. Pans Per Individual Weekday.

No. of W.C. Ops	Average Total Usage, 8 a.m.- 3 p.m.	Average W.C.1, 8 a.m.- 3 p.m.	Average W.C.2, 8 a.m.- 3 p.m.	Average W.C.3, 8 a.m.- 3 p.m.	Average W.C.4, 8 a.m.- 3 p.m.
Monday	229.17 (20.1%)	51.18 (19.7%)	54.86 (19.5%)	66.98 (19.8%)	56.15 (21.4%)
Tuesday	246.78 (21.6%)	60.10 (23.3%)	62.43 (22.2%)	72.65 (21.5%)	51.60 (19.6%)
Wednesday	232.35 (20.4%)	46.66 (18.0%)	53.52 (19.1%)	73.32 (21.7%)	58.85 (22.4%)
Thursday	235.42 (20.6%)	61.59 (23.8%)	61.50 (21.9%)	64.42 (19.0%)	47.91 (18.2%)
Friday	197.66 (17.3%)	39.78 (15.3%)	48.45 (17.3%)	61.27 (18.1%)	48.16 (18.3%)
TOTALS	1141.38 (100%)	259.31 (100%)	280.76 (100%)	338.64 (100%)	262.67 (100%)

FIGURE 10/8. - Comparative Overall Usage of Female Facility W.C. Pans Per Individual Weekday.

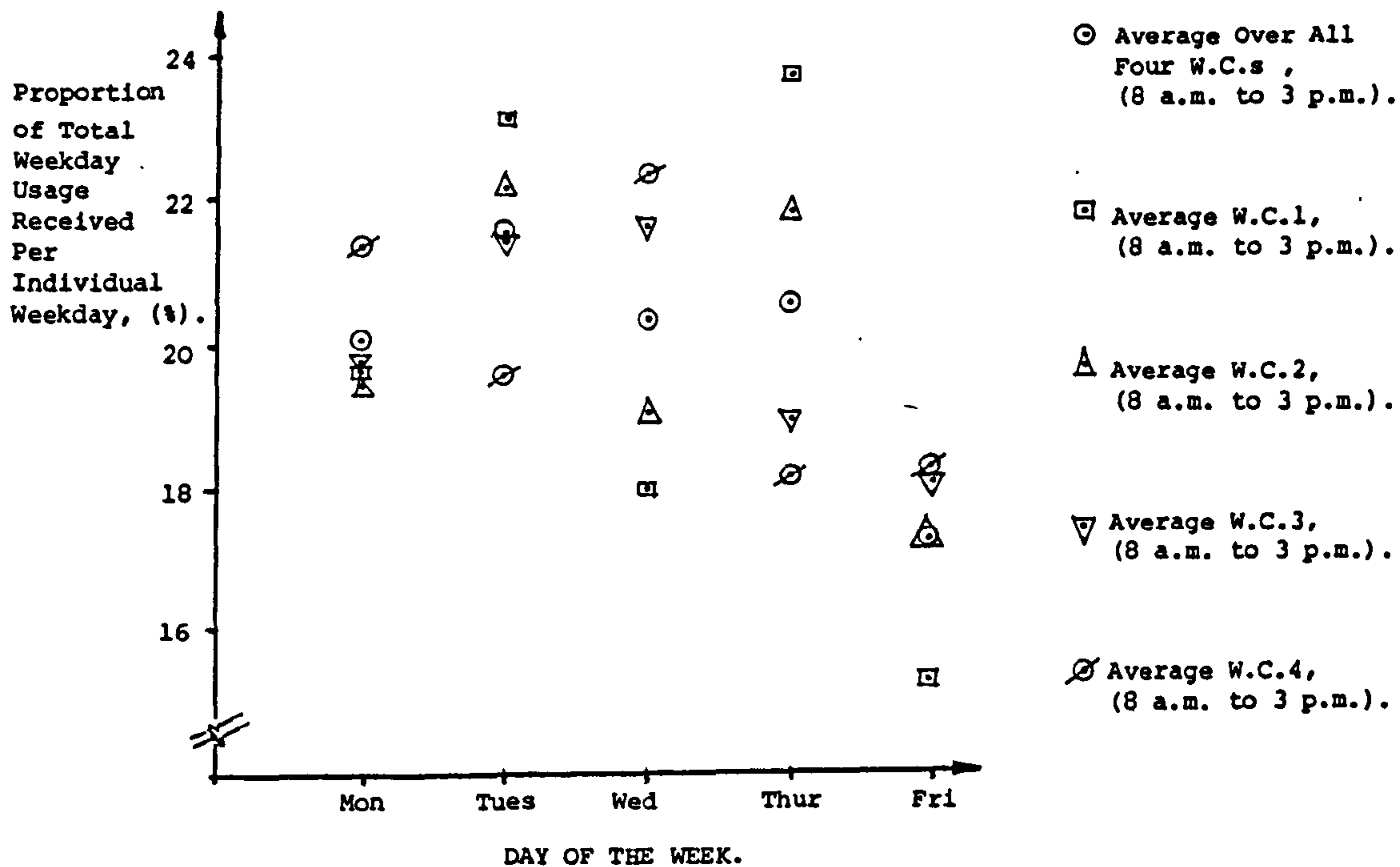

FIGURE 10/9. - Graphical Presentation of Comparative Overall Usage of Female Facility W.C. Pans Per Individual Weekday.

SITUATION	MALE FACILITY Mean Occupation Time (sec).	FEMALE FACILITY Mean Occupation Time (sec).
OFFICE BUILDING **		
W.C.	267	80
Urinal	39	-
Washbasin	18	19
SHOPPING CENTRE ***		
W.C.	184 (54*)	92
Urinal	35	-
Washbasin	14	20

*Often used as urinal, ** Davidson and Courtney (1976), *** Flenning (1977).

FIGURE 10/10. - Mean Occupation Times For Sanitary
Fitments.

	Male	Female
Use only the washbasin.	10%	13%
Use the W.C. first.	11%	87%
Use the urinal first.	79%	-

Davidson and Courtney (1976)

FIGURE 10/11. - Relative Usage of Sanitary Appliances
in Offices During Peak Periods.

OFFICE BUILDING No.	MALE FACILITY			FEMALE FACILITY		
	Popul- ation	Mean Rate	%	Popul- ation	Mean Rate	%
1	8	0.14	1.8	25	0.9	3.6
2	72	1.8	2.5	56	1.6	2.9
3	24	1.0	4.0	45	2.0	4.4
4	92	3.0	3.3	39	1.8	4.6
5	262	8.2	3.1	136	4.0	2.9
6	35	1.4	4.0	52	1.4	2.7
7	31	0.9	2.9	38	1.0	2.6
ADOPTED AVERAGE			3.0			3.5

Davidson and Courtney (1976).

FIGURE 10/12. - Demand Rates in Office Buildings,
mean number of arrivals per five
minutes during peak periods, both
actual and as a percentage of the
population.

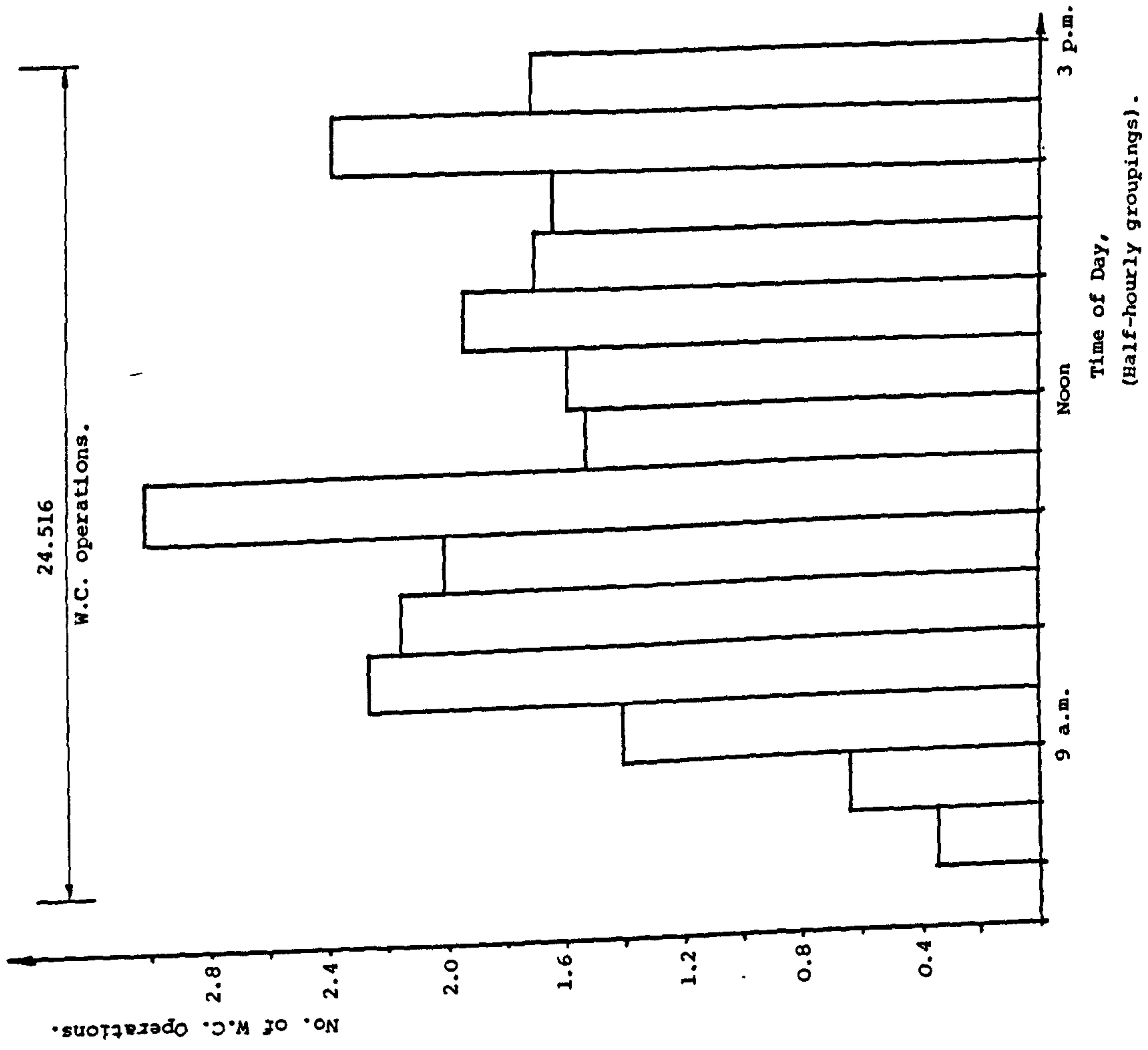

FIGURE 10/14. - Total W.C. Usage Per Mean Weekday, 8 a.m. to 3 p.m., at the Male Facility, (Both W.C.s).

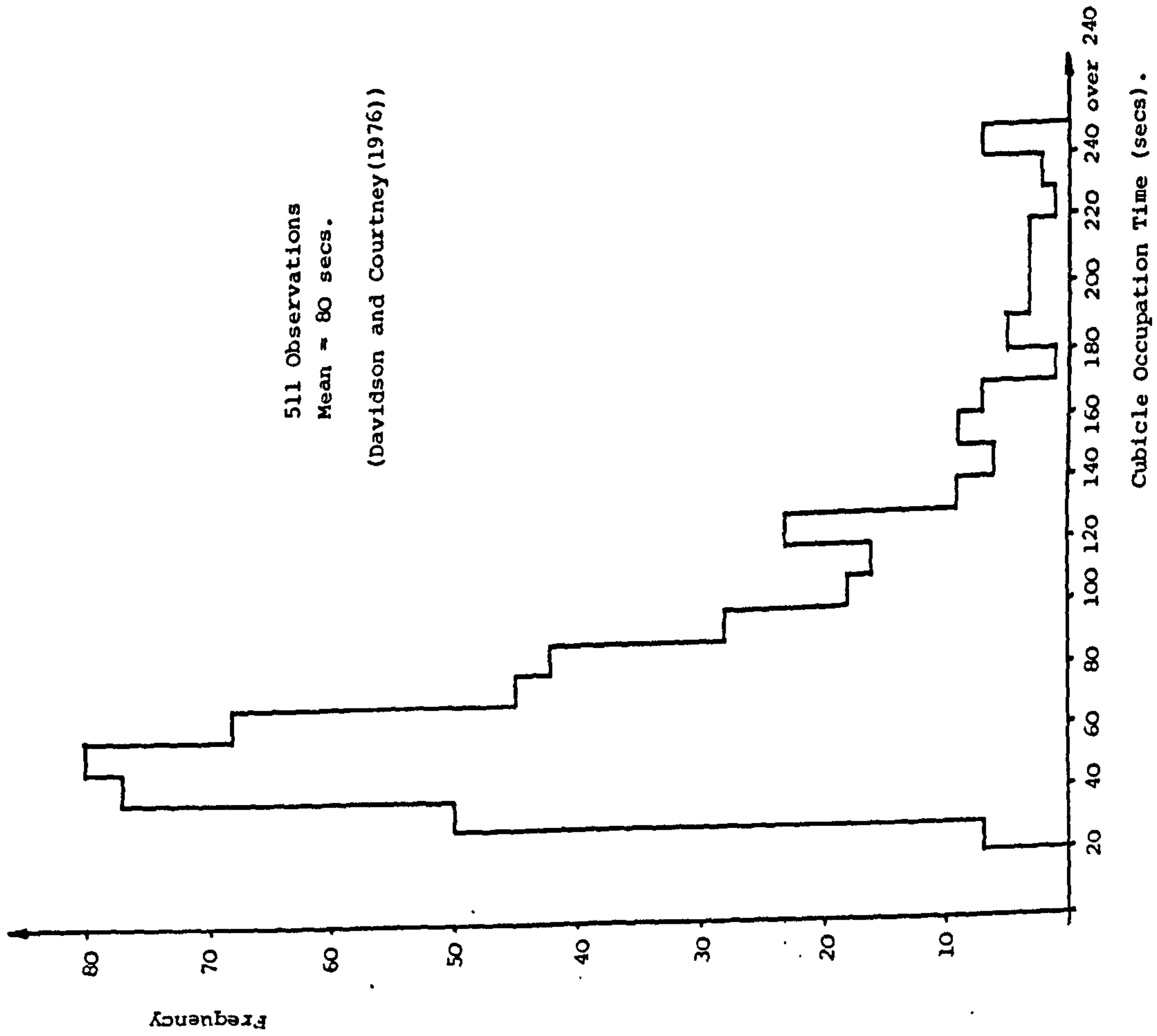

FIGURE 10/13. - Distribution of Occupation Times for Female W.C. Cubicles.

TIME PERIOD	TUESDAY			WEDNESDAY			FRIDAY		
	W.C.6	W.C.5	TOTAL	W.C.6	W.C.5	TOTAL	W.C.6	W.C.5	TOTAL
a.m.									
8.-8.30	0.000	0.333	0.333	0.125	0.125	0.250	0.143	0.286	0.429
8.30-9.	0.222	0.111	0.333	0.250	0.750	1.000	0.429	0.143	0.571
9.-9.30	0.778	0.444	1.222	1.250	0.750	2.000	1.000	0.000	1.000
9.30-10.	1.778	0.889	2.667	1.250	0.875	2.125	1.143	0.857	2.000
10.-10.30	1.444	1.000	2.444	1.125	0.750	1.875	1.143	1.000	2.143
10.30-11.	1.000	0.889	1.889	1.000	0.875	1.875	1.429	1.000	2.429
11.-11.30	1.444	1.778	3.222	1.125	1.250	2.375	2.000	1.857	3.857
11.30-12.	1.000	0.778	1.778	0.625	0.750	1.375	1.000	0.429	1.429
12.-12.30	1.300	0.300	1.600	0.375	0.500	0.875	1.143	1.143	2.286
12.30 -1.	1.400	1.100	2.500	1.375	0.375	1.750	1.286	0.286	1.571
1.-1.30	1.400	0.900	2.300	0.875	0.500	1.375	1.000	0.429	1.429
1.30-2.	1.000	0.889	1.889	1.125	0.750	1.875	0.667	0.500	1.167
2.-2.30	1.556	1.778	3.333	1.000	0.625	1.625	1.600	0.600	2.200
2.30-3. p.m.	1.333	0.444	1.778	0.875	0.750	1.625	0.750	1.000	1.750
TOTALS	15.656	11.633	27.289	12.375	9.625	22.000	14.731	9.529	24.260

FIGURE 10/15. - Average Male Facility W.C. usage During "On-Site" Periods.

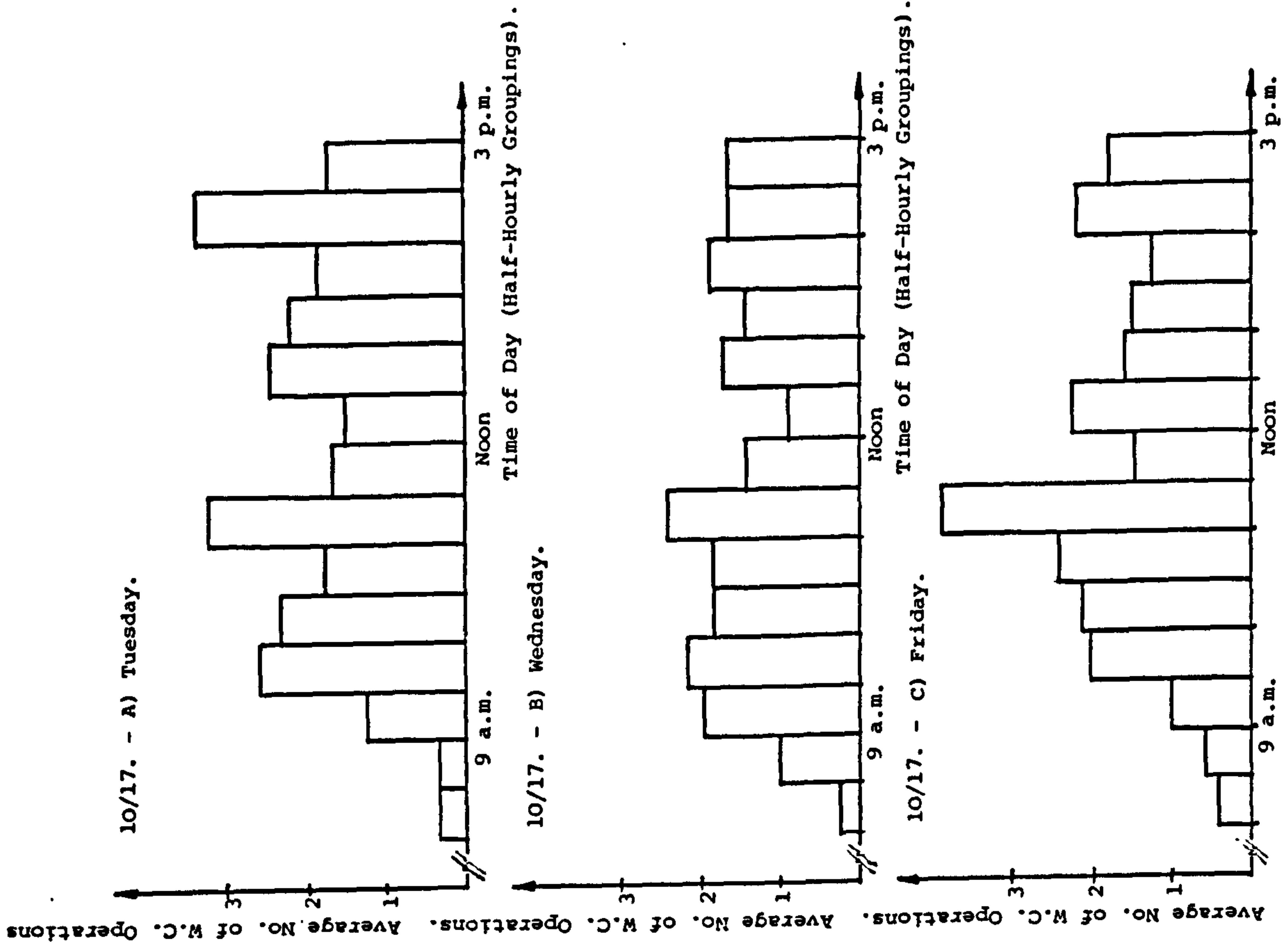

FIGURE 10/17. - AVERAGE USAGE OF MALE FACILITY W.C. PANS PER INDIVIDUAL WEEKDAY.

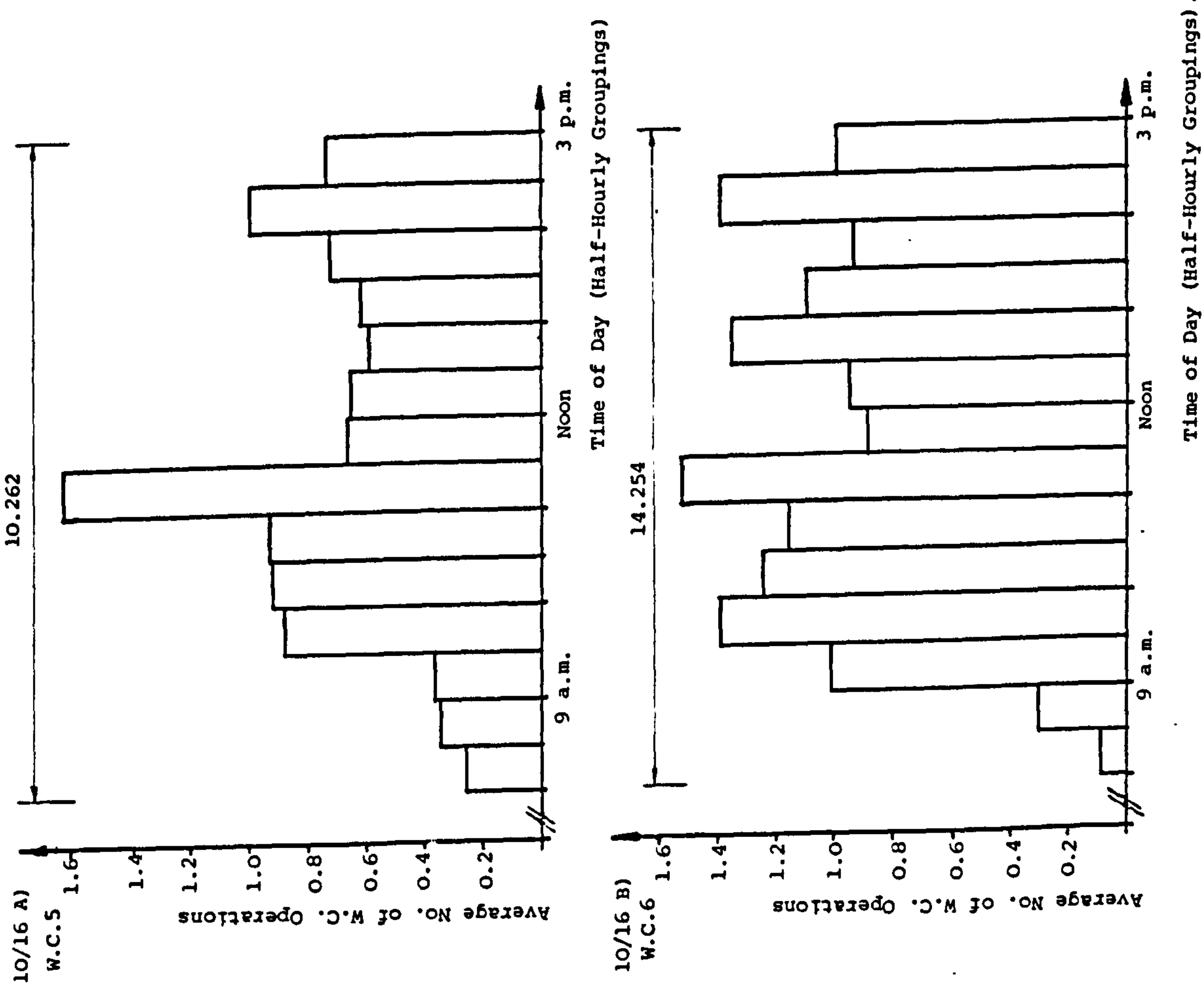

FIGURE 10/16. - MEAN WEEKDAY USAGE PER INDIVIDUAL MALE FACILITY W.C. PAN.

NUMBER OF W.C. CFS.	TOTAL W.C. DATA.	WEEKDAY 8 a.m. - 3 p.m.	WEEKEND 8 a.m. - 3 p.m.	FRIDAY 8 a.m. - 3 p.m.
W.C.5	1369 (46,601)	11,633 (42,601)	9,625 (41,001)	9,529 (39,701)
W.C.6	1567 (51,411)	15,656 (57,401)	12,375 (56,701)	14,731 (60,701)
TOTAL	2936 (1000)	27,289 (1000)	22,000 (1000)	24,260 (1000)

FIGURE 10.18. - COMPARATIVE OVERALL USAGE OF INDIVIDUAL MALE W.C. PANS.

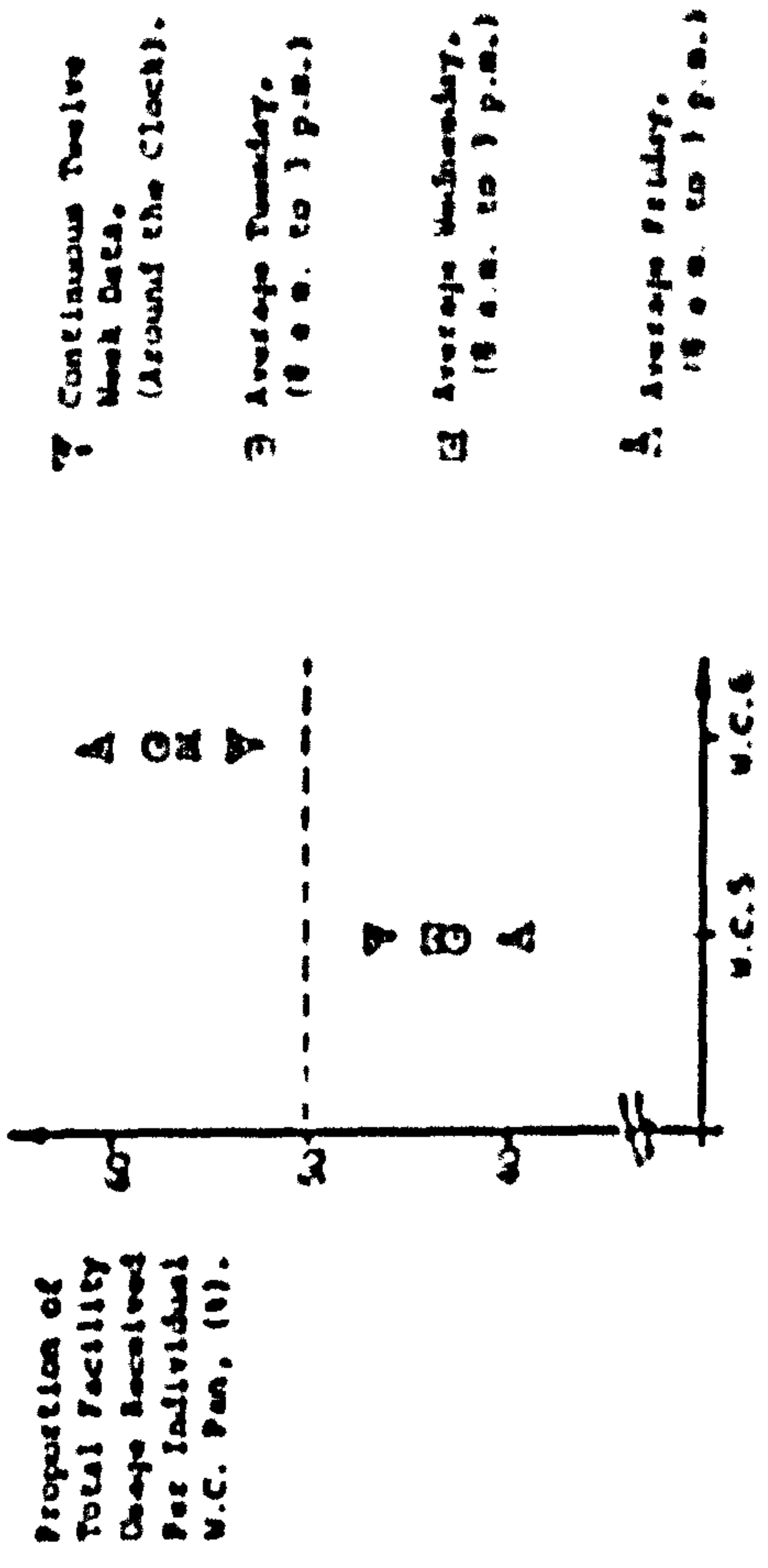

FIGURE 10.19. - GRAPHICAL PRESENTATION OF COMPARATIVE OVERALL USAGE OF INDIVIDUAL MALE FACILITY W.C. PANS.

NUMBER OF W.C. CFS.	AVERAGE USAGE PER W.C. PAN	W.C.5	W.C.6
TOTAL	27,289 (100)	22,000 (100)	5,289 (100)
W.C.5	11,633 (100)	9,625 (100)	2,008 (100)
W.C.6	15,656 (100)	12,375 (100)	3,281 (100)
TOTAL	27,289 (100)	22,000 (100)	5,289 (100)

FIGURE 10.19. - COMPARATIVE OVERALL USAGE OF MALE FACILITY W.C. PANS PER INDIVIDUAL W.C. PAN.

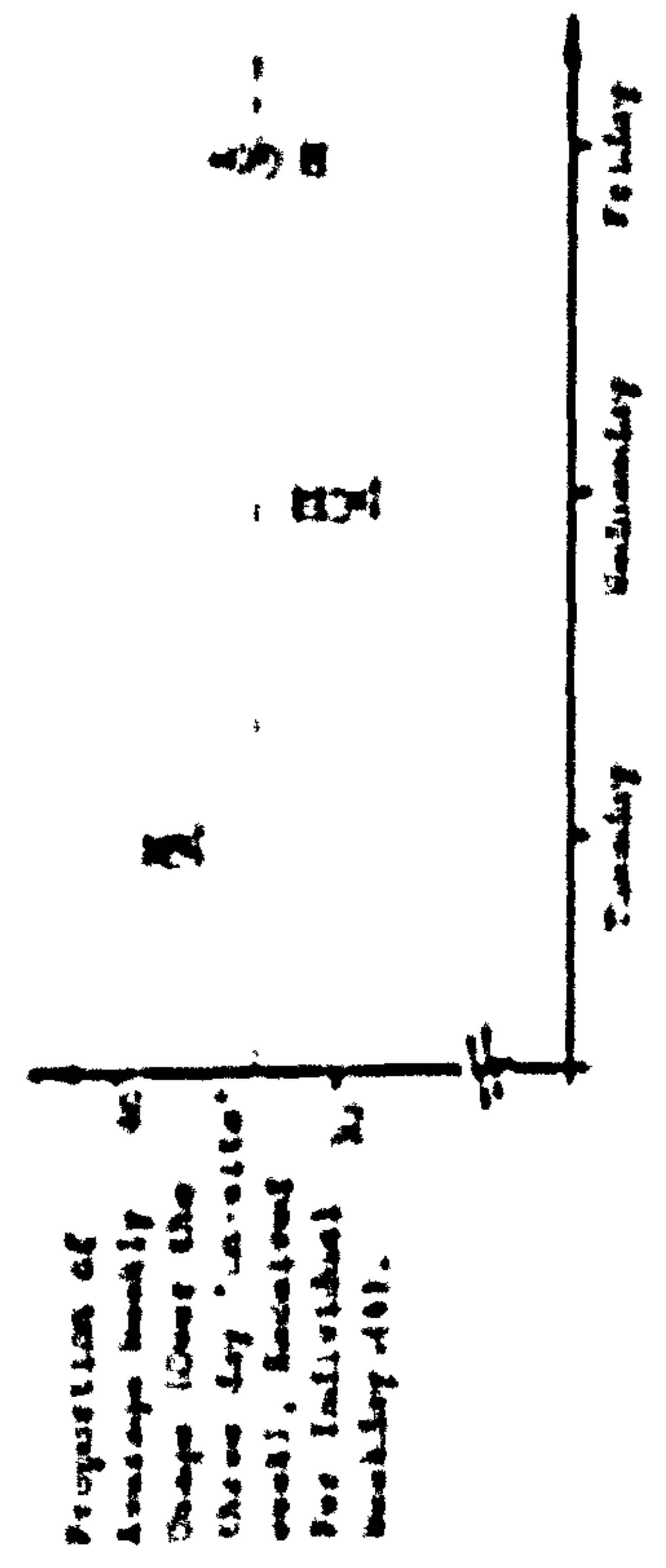

FIGURE 10.21. - GRAPHICAL PRESENTATION OF COMPARATIVE OVERALL USAGE OF MALE FACILITY W.C. PANS PER INDIVIDUAL W.C. PAN.

	0	1	2	3	4	5	6	7	8	9	TOTAL
FEMALE FACILITY.											
Number of Solids Evacuated by W.C.											
Number of Flushes.	653	967	225	69	43	28	10	2	2	0	1,999
Proportion as of Total, (%).	32.67	48.37	11.26	3.45	2.15	1.40	0.50	0.10	0.10	—	100.
Number of 'Faecal' Flushes.	—	20	37	46	37	26	10	2	2	0	180
Prop. of 'Faecal' as of Total Flushes, (%).	—	1.00	1.85	2.30	1.85	1.30	0.50	0.10	0.10	—	9.00
Number of 'Non-Faecal' Flushes.	—	947	188	23	6	2	0	0	0	0	1,166
Prop. of 'Non-Faecal' as of Tot. Flushes, (%).	—	47.37	9.40	1.15	0.30	0.10	—	—	—	—	58.33
MALE FACILITY.											
Number of Flushes.	180	78	84	49	38	27	22	11	8	2	499
Proportion as of Total, (%).	36.07	15.63	16.83	9.82	7.62	5.41	4.41	2.20	1.60	0.40	100.
Number of 'Faecal' Flushes.	—	13	49	40	35	27	22	10	8	2	206
Prop. of 'Faecal' as of Total Flushes, (%).	—	2.61	9.82	8.02	7.01	5.41	4.41	2.00	1.60	0.40	41.28
Number of 'Non-Faecal' Flushes.	—	65	35	9	3	0	0	1	0	0	111
Prop. of 'Non-Faecal' as of Tot. Flushes, (%).	—	13.03	7.01	1.80	0.60	—	—	0.20	—	—	22.65

PLATE 10/22. - Rate of Occurrence of Distinctive Flush Types. - In respect to the number of solids at evacuation from the W.C., and based upon all unflushed 'single' flushes.

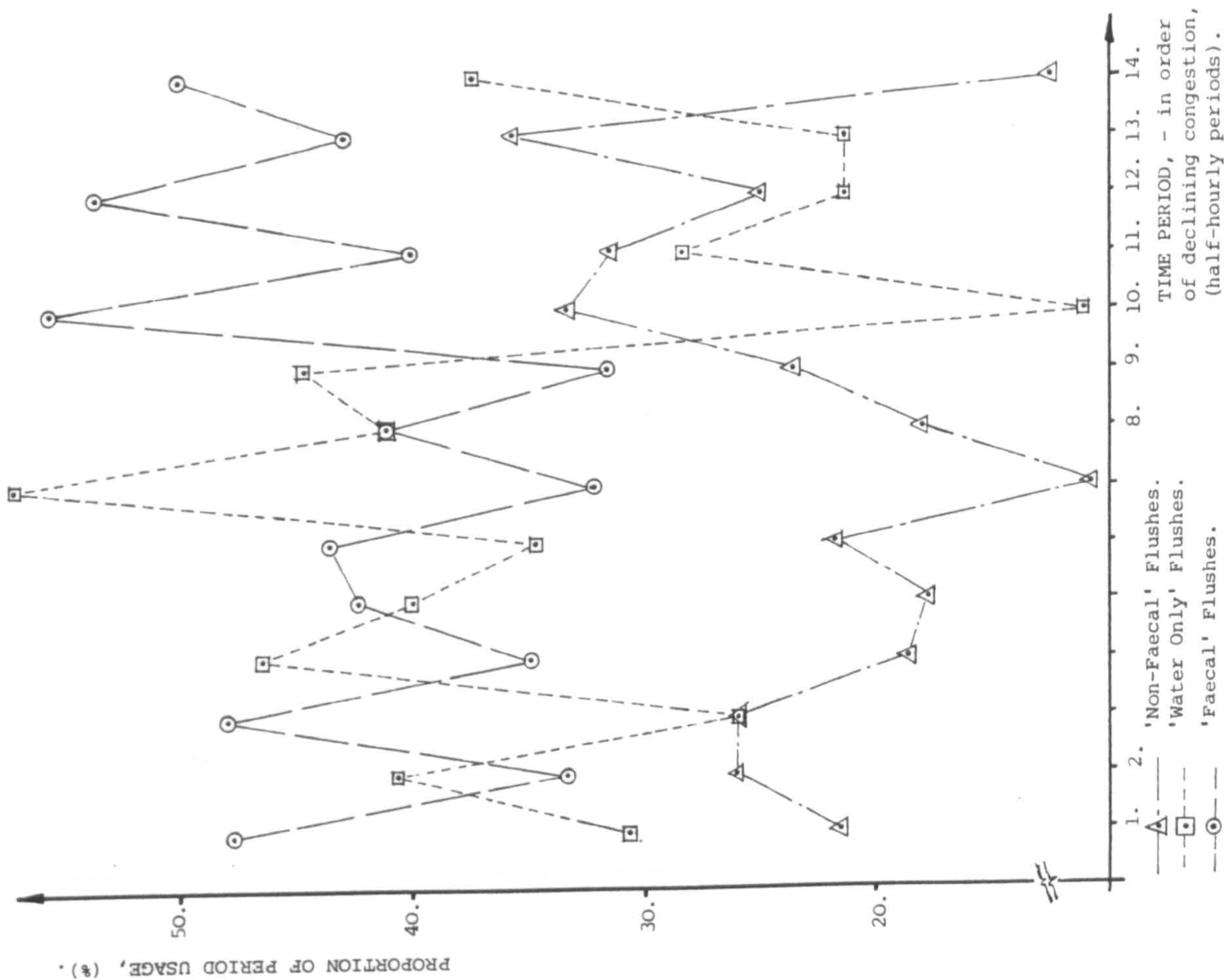

FIGURE 10/24. - GRAPHICAL PRESENTATION OF MALE FACILITY FLUSH CONTENT, - with respect to level of demand over half-hourly periods.

Period Code in Order of Declining Congestion.	Time Period.	Mean Period Usage, as a Prop. of Mean Weekday 8.a.m. to 3.p.m. Usage, (%)	Mean No. of 'Faecal' Flushes, as a Prop. of Mean Period Usage, (%)	Mean No. of 'Non-Faecal' Flushes, as a Prop. of Mean Period Usage, (%)	Mean No. of 'Water Only' Flushes, as a Prop. of Mean Period Usage, (%)
1	11.-11.30 a.m.	12.85	47.69	21.54	30.77
2	2.-2.30 p.m.	9.73	33.33	25.93	40.74
3	9.30-10. a.m.	9.23	47.83	26.09	26.09
4	10.-10.30 a.m.	8.78	34.88	18.60	46.51
5	10.30-11. a.m.	8.42	42.22	17.78	40.00
6	12.30-1. p.m.	7.91	43.48	21.74	34.78
7	2.30-3. p.m.	7.01	32.14	10.71	57.14
8	1.-1.30 p.m.	6.94	41.03	17.95	41.03
9	1.30-2. p.m.	6.71	31.58	23.68	44.74
10	12.-12.30 p.m.	6.47	55.56	33.33	11.11
11	11.30-12. a.m.	6.23	40.00	31.43	28.57
12	9.-9.30 a.m.	5.74	53.57	25.00	21.43
13	8.30-9. a.m.	2.59	42.86	35.71	21.43
14	8.-8.30 a.m.	1.37	50.00	12.50	37.50

FIGURE 10/23. - MALE FACILITY FLUSH CONTENT, - with respect to level of demand over half-hourly periods.

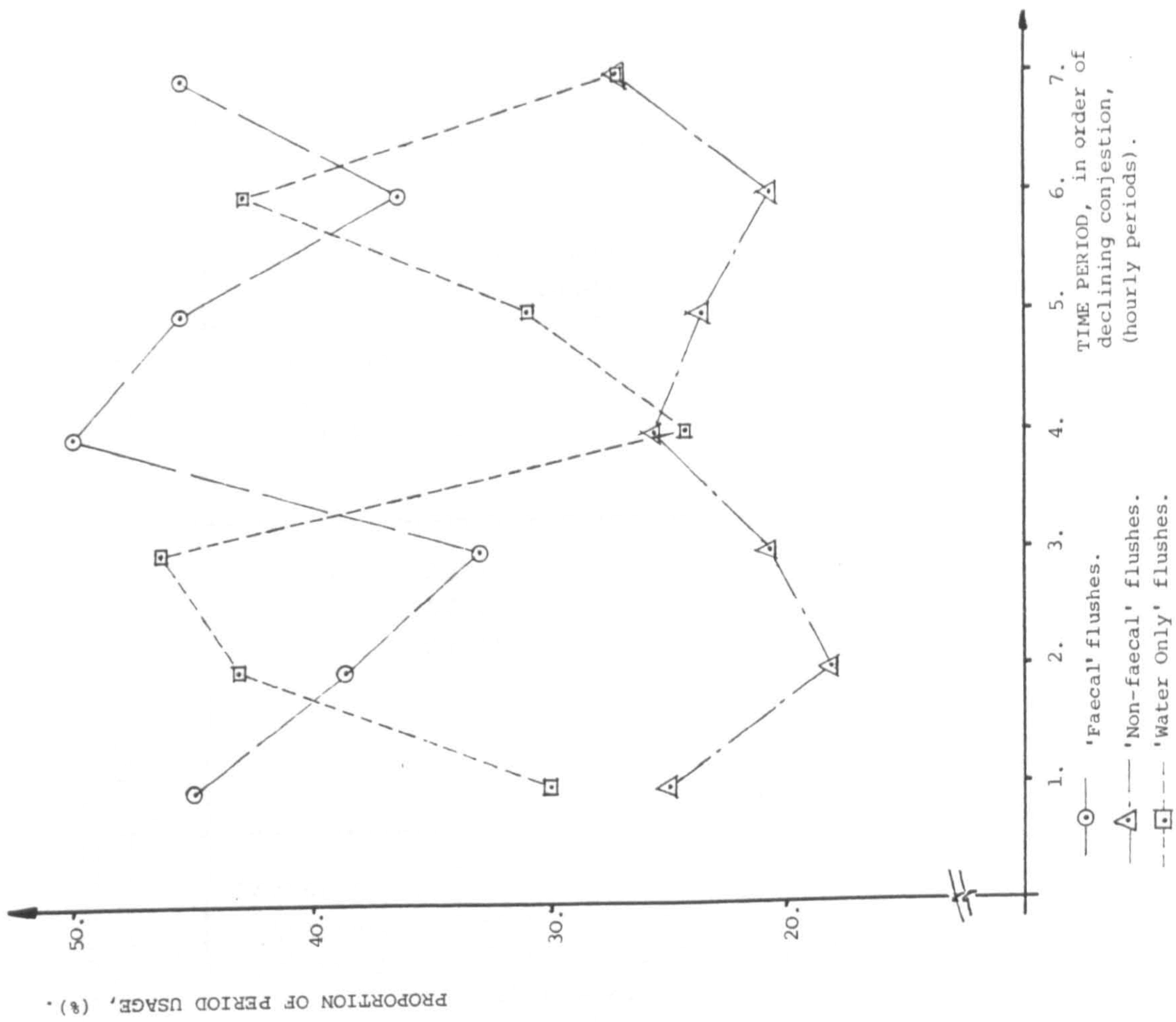
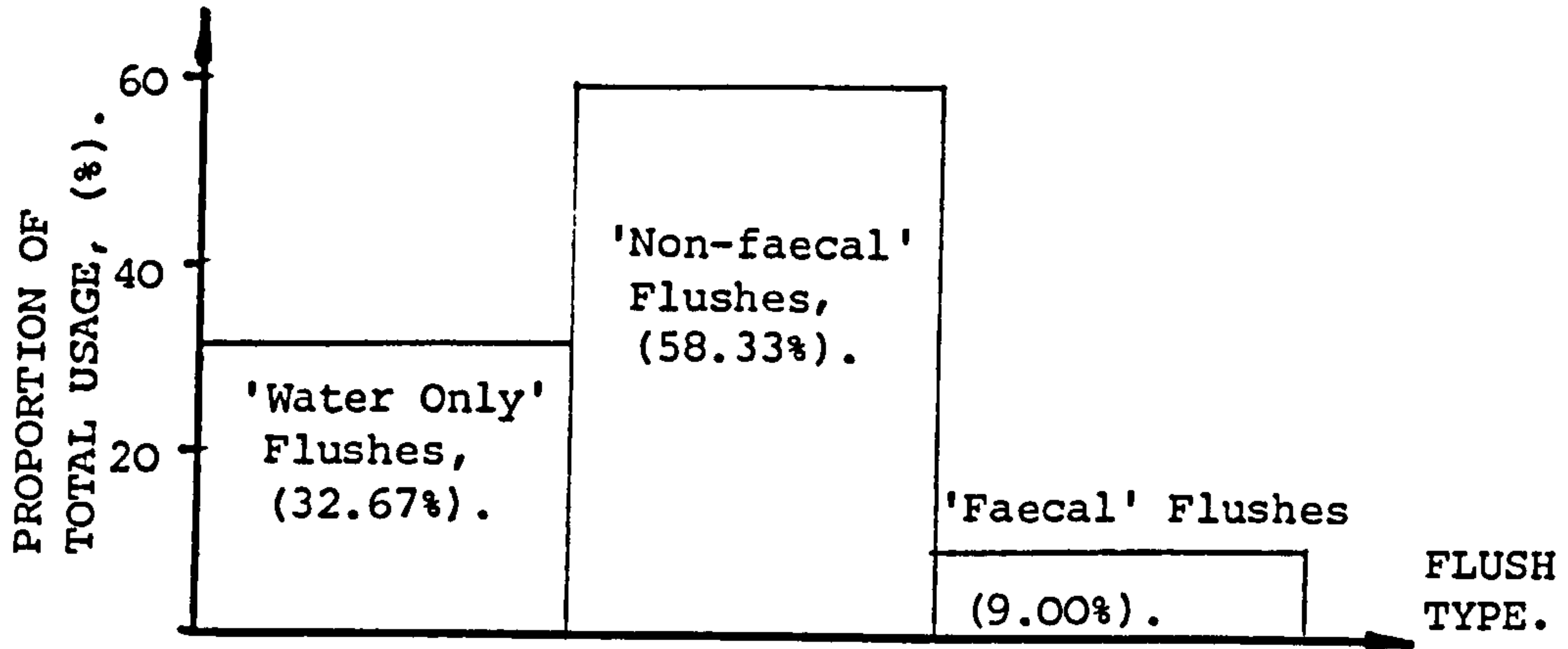

FIGURE 10/26. - GRAPHICAL PRESENTATION OF MALE FACILITY FLUSH CONTENT, with respect to level of demand over hourly periods.

Period Code, in Order of Declining Congestion.	Time Period.	Mean Period Usage, as a Prop. of Mean Weekday 8.a.m. to 3.p.m. Usage, (%).	Mean Number of 'Faecal' Flushes, as a Prop. of Mean Period Usage, (%).	Mean No. of 'Non-Faecal' Flushes, as a Prop. of Mean Period Usage, (%).	Mean No. of 'Water-Only' Flushes, as a Prop. of Mean Period Usage, (%).
1	11.-12. a.m.	19.08	45.00	25.00	30.00
2	10.-11. a.m.	17.21	38.64	18.18	43.18
3	2.-3. p.m.	16.74	32.93	20.73	46.34
4	9.-10. a.m.	14.97	50.00	25.64	24.32
5	12.-1. p.m.	14.39	45.45	23.64	30.91
6	1.-2. p.m.	13.64	36.36	20.78	42.86
7	8.-9. a.m.	3.96	45.46	27.27	27.27

FIGURE 10/25. - MALE FACILITY FLUSH CONTENT, with respect to level of demand over hourly periods.

FIGURE 10/26. - GRAPHICAL PRESENTATION OF MALE FACILITY FLUSH CONTENT, with respect to level of demand over hourly periods.



10/27. - A). FEMALE FACILITY AS OBSERVED, AND AS PREDICTED FOR A 'NORMAL' SUCH FACILITY.

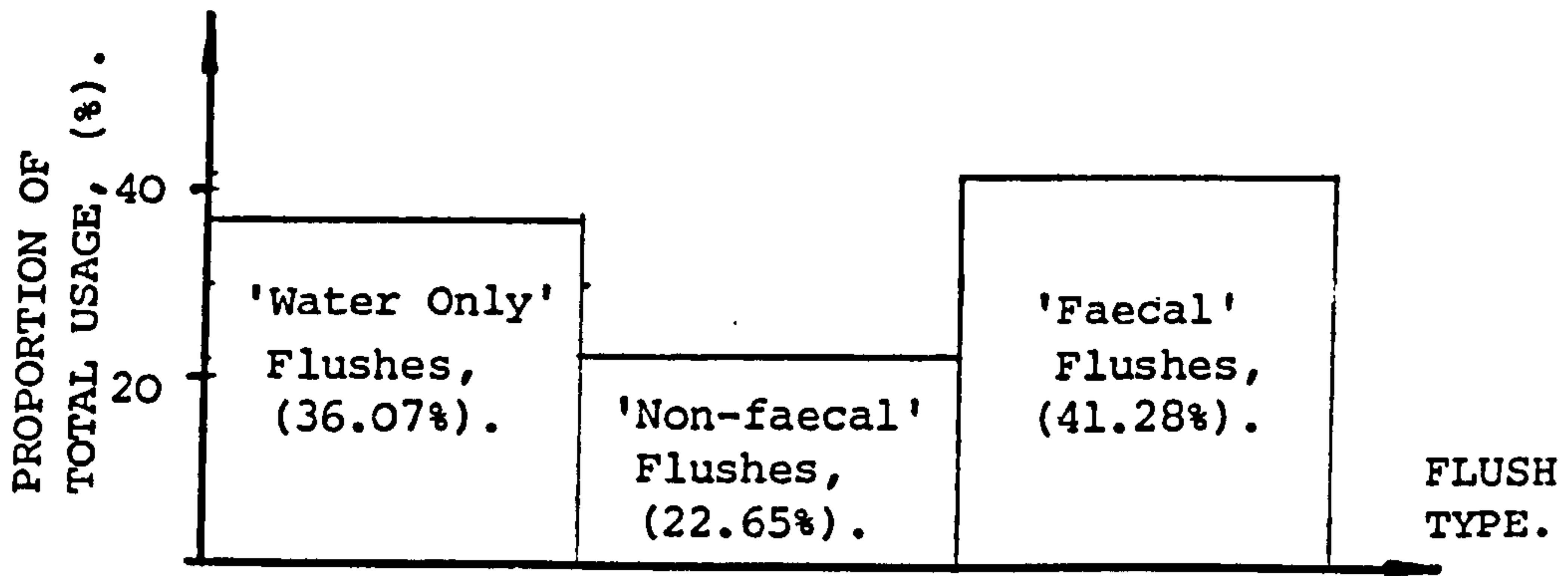

10/27. - B). MALE FACILITY, AS OBSERVED.

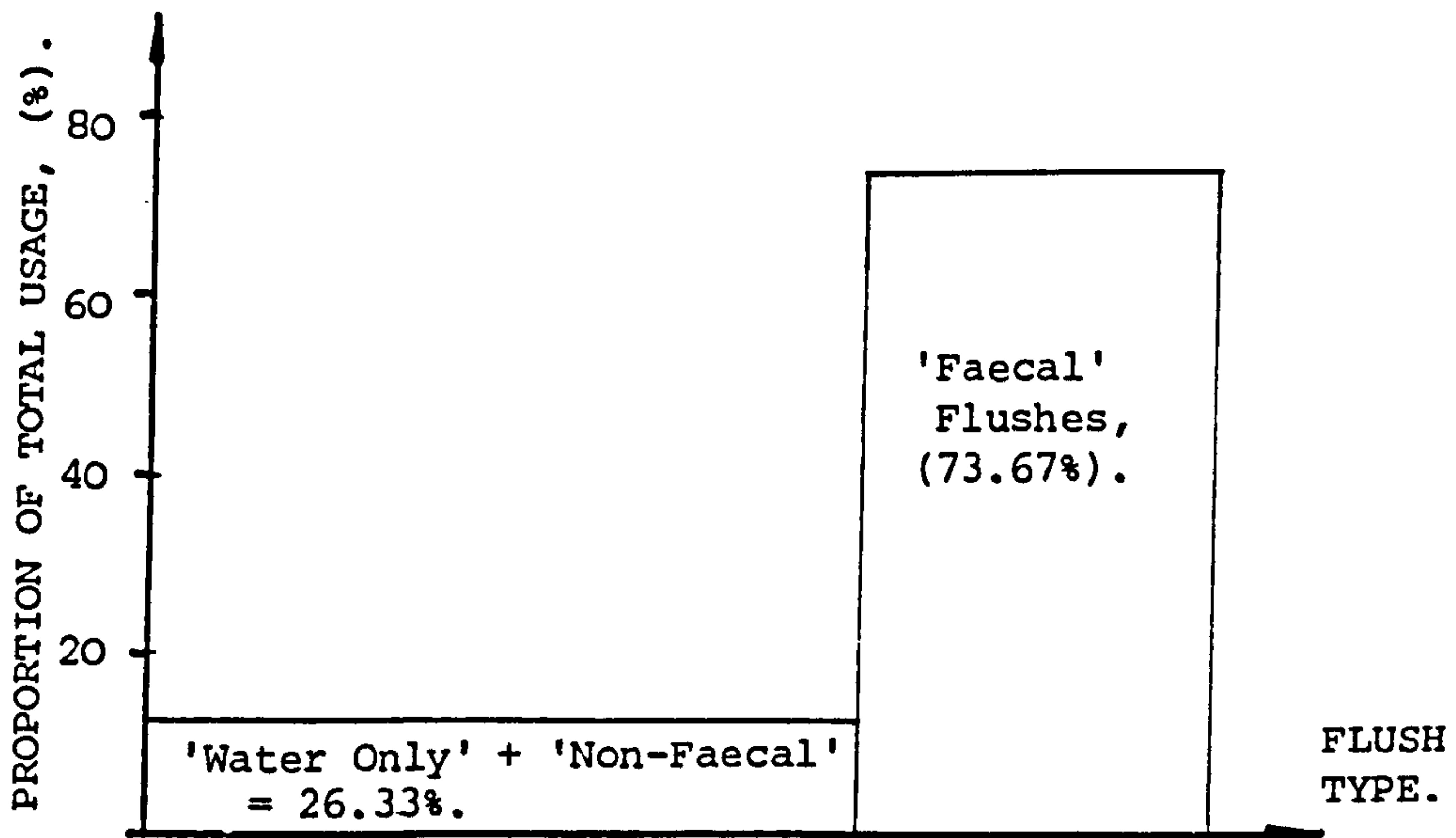

10/27. - C). AS PREDICTED FOR A 'NORMAL' MALE FACILITY.

FIGURE 10/27. - Graphical Presentation of the Observed and Predicted Proportional Rates of Occurrence of the Different Flush Types, - as observed 'on-site', and as predicted for 'normal' facilities.

MEAN NUMBER OF SOLIDS PER FLUSH			
	FEMALE FACILITY		MALE FACILITY GRADIENT 1:150
	GRADIENT 1:150	GRADIENT 1:200	
	'FAECAL' FLUSHES.	1.762 0.129 1.049 0.010 2.950 (Based upon 101 flushes).	
	FAECAL SOLIDS. FAECAL/TISSUE SOLIDS. TOILET/TISSUE-PAPER SOLIDS OTHER NON-FAECAL SOLIDS. TOTAL SOLID CONTENT.		
'NON-FAECAL' FLUSHES.	1.1520 0.0691 1.2211 (Based upon 549 flushes).	1.1959 0.0290 1.2249 (Based upon 587 flushes).	1.4868 0.1150 1.6018 (Based upon 113 flushes).
	TOILET/TISSUE-PAPER SOLIDS OTHER NON-FAECAL SOLIDS. TOTAL SOLID CONTENT.		

FIGURE 10/28. - Summary of the Mean Numbers of Particular and Total Solids per Flush Type, - based upon the content, at evacuation from the W.C., of all monitored 'single' flushes.

	NUMBER OF SOLIDS EVACUATED BY THE W.C.										TOTAL	
	1	2	3	4	5	6	7	8	9	10		
FEMALE FACILITY Gradient 1:150.	No. of Flushes Containing Some Faecal Material.	13	30	26	19	8	4	1	-			101
	No. Faecal Solids Involved.	6	30	46	48	28	15	5	-			178
	No. of Faecal/Tissue Solids Involved.	7	4	1	1	0	0	0	0	-		13
	No. of Non-Faecal Solids Involved.	-	26	31	27	12	9	2	-			107
	Mean No. of Faecal Solids Per Flush.	0.462	1.000	1.769	2.526	3.500	3.750	5.000	-			1.762
	Mean No. of Faecal/Tissue Solids Per Flush.	0.538	0.133	0.038	0.053	0	0	0	-			0.129
	Mean No of Non-Faecal Solids Per Flush.	-	0.867	1.192	1.421	1.500	2.250	2.000	-			1.059
FEMALE FACILITY Gradient 1:200.	No. of Flushes Containing Some Faecal Material.	7	7	20	18	18	6	1	2			79
	No. of Faecal Solids Involved.	3	7	31	46	56	25	6	9			183
	No. of Faecal/Tissue Solids Involved.	4	1	3	1	1	0	0	1			11
	No. of Non-Faecal Solids Involved.	-	6	26	25	33	11	1	6			108
	Mean No. of Faecal Solids Per Flush.	0.429	1.000	1.550	2.555	3.111	4.167	6.000	4.500			2.316
	Mean No. of Faecal/Tissue Solids Per Flush.	0.571	0.143	0.150	0.056	0.056	0	0	0.500			0.139
	Mean No. of Non-Faecal Solids Per Flush.	-	0.857	1.300	1.389	1.833	1.833	1.000	3.000			1.367

FIGURE 10/29. - RELATIVE NUMBERS OF DISTINCTIVE SOLID TYPES AS CONSTITUENTS IN 'FAECAL' FLUSHES, IN RESPECT TO THE NUMBER OF SOLIDS AT EVACUATION FROM THE W.C., FOR THE DIFFERENT GRADIENT OBSERVATIONS AT THE FEMALE FACILITY, - (Based Upon 'Single' Flushes Only).

	NUMBER OF SOLIDS EVACUATED BY THE W.C.										TOTAL.	
	1	2	3	4	5	6	7	8	9	10		
FEMALE FACILITY (Irrespective of Gradient).	No. of Flushes Containing Some Faecal Material.	20	37	46	37	26	10	2	2	0	0	180
	No. of Faecal Solids Involved.	9	37	77	94	84	40	11	9	0	0	361
	No. of Faecal/Tissue Solids Involved.	11	5	4	2	1	0	0	1	0	0	24
	No. of Non-Faecal Solids Involved.	-	32	57	52	45	20	3	6	0	0	215
	Mean No. of Faecal Solids Per Flush.	0.45	1.00	1.67	2.54	3.23	4.00	5.50	4.50	-	-	2.01
	Mean No. of Faecal/Tissue Solids Per Flush.	0.55	0.14	0.09	0.05	0.04	-	-	0.50	-	-	0.13
	Mean No. of Non-Faecal Solids Per Flush.	-	0.86	1.24	1.41	1.73	2.00	1.50	3.00	-	-	1.19
	No. of Flushes Containing Some Faecal Material.	13	49	40	35	27	22	10	8	2	0	206
	No. of Faecal Solids Involved.	5	48	60	95	86	92	46	37	12	0	481
	No. of Faecal/Tissue Solids Involved.	8	13	8	1	2	0	2	1	0	0	35
No. of Non-Faecal Solids Involved.	-	37	52	44	47	40	22	26	6	0	274	
Mean No. of Faecal Solids Per Flush.	0.38	0.98	1.50	2.71	3.19	4.18	4.60	4.63	6.00	-	2.33	
Mean No. of Faecal/Tissue Solids Per Flush.	0.62	0.27	0.20	0.03	0.07	-	0.20	0.12	-	-	0.17	
Mean No. of Non-Faecal Solids Per Flush.	-	0.76	1.30	1.26	1.74	1.82	2.20	3.25	3.00	-	1.33	

FIGURE 10/30. - RELATIVE NUMBERS OF DISTINCTIVE SOLID TYPES AS CONSTITUENTS IN 'FAECAL' FLUSHES, IN RESPECT TO THE NUMBER OF SOLIDS AT EVACUATION FROM THE W.C., FOR EACH OF THE MALE AND FEMALE FACILITY OBSERVATIONS, - (Based Upon 'Single' Flushes Only).

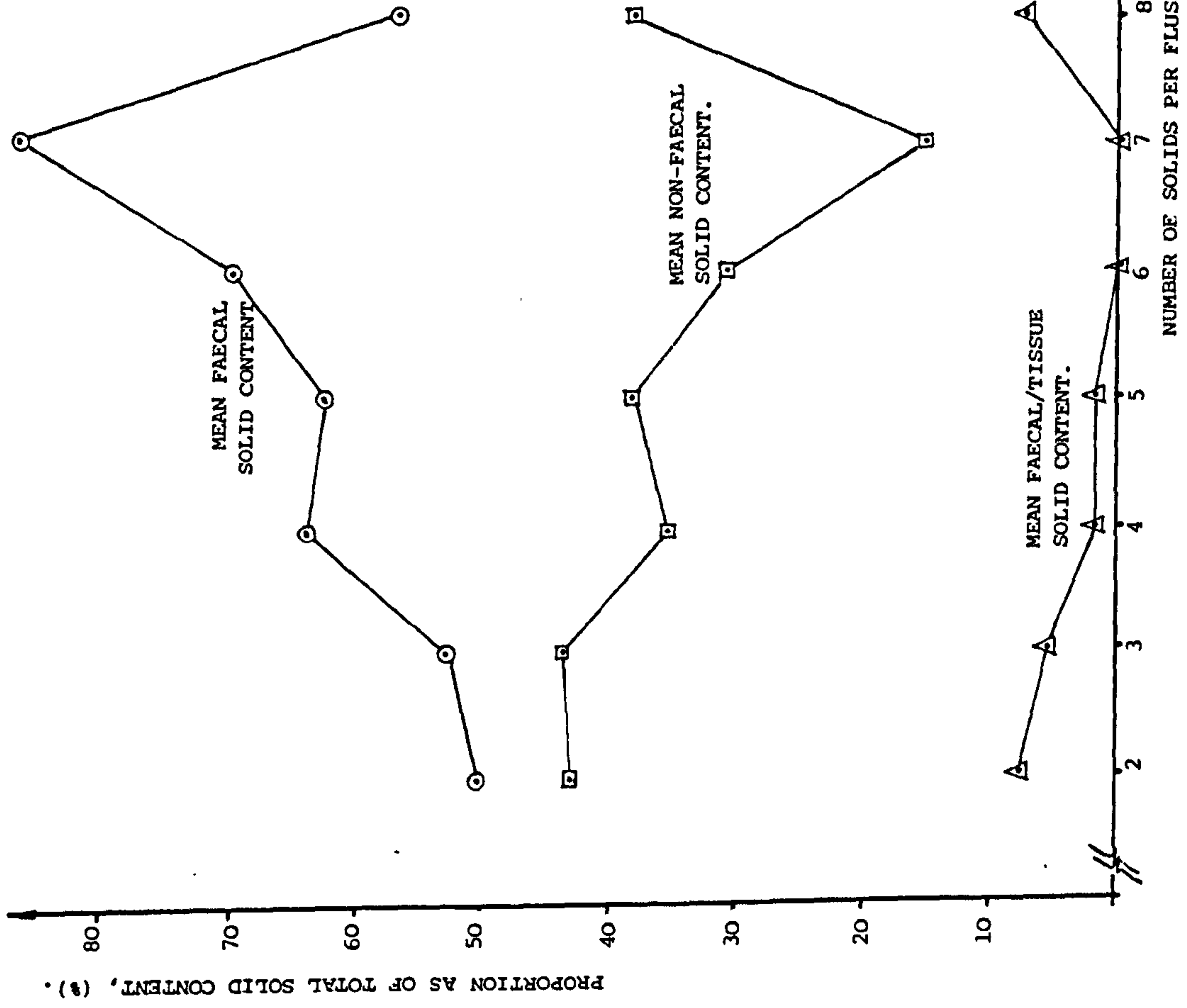

FIGURE 10/32. - GRAPHICAL PRESENTATION OF THE PROPORTIONAL RATE OF OCCURRENCE OF DISTINCTIVE SOLID TYPES AS CONSTITUENTS IN 'FAECAL' FLUSHES, IN RESPECT OF THE NUMBER OF SOLIDS AT EVACUATION FROM THE W.C., FOR GRADIENT 1:200 AT THE FEMALE FACILITY.

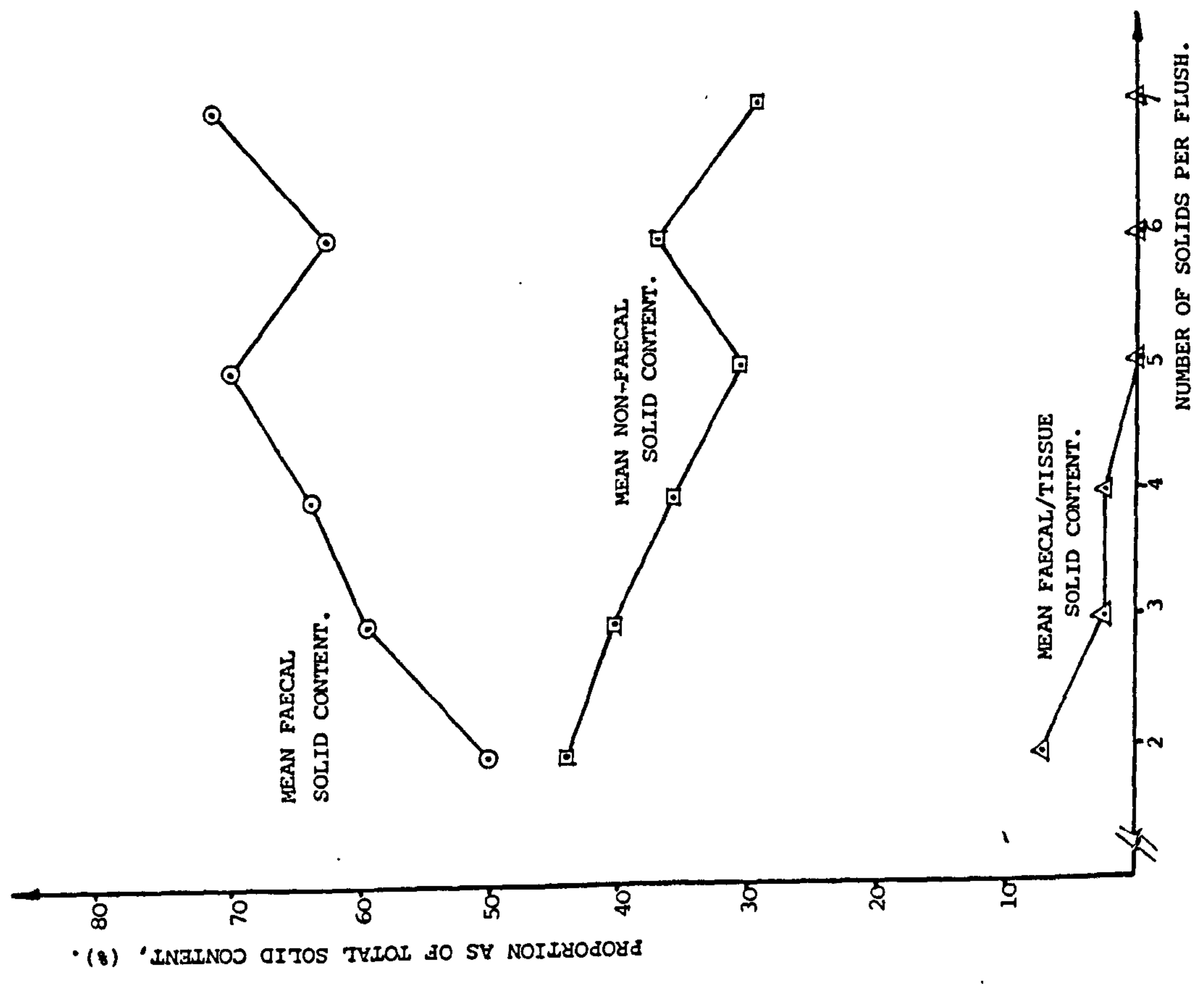

FIGURE 10/31. - GRAPHICAL PRESENTATION OF THE PROPORTIONAL RATE OF OCCURRENCE OF DISTINCTIVE SOLID TYPES AS CONSTITUENTS IN 'FAECAL' FLUSHES, IN RESPECT TO THE NUMBER OF SOLIDS AT EVACUATION FROM THE W.C., FOR GRADIENT 1:150 AT THE FEMALE FACILITY.

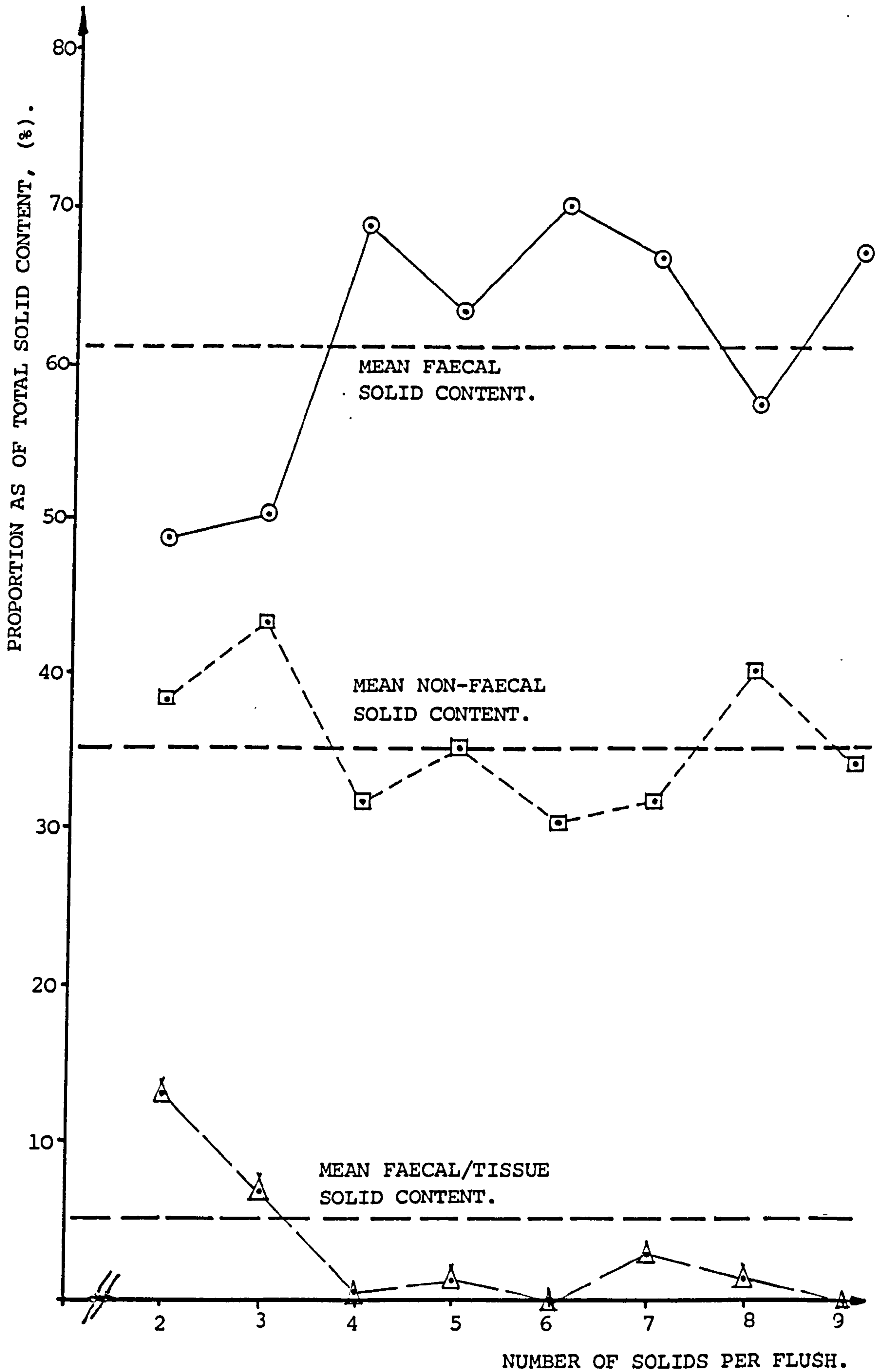

FIGURE 10/33. - Graphical Presentation of the Proportional Rate of Occurrence of Distinctive Solid Types as Constituents in 'Faecal' Flushes, in Respect to the Number of Solids at Evacuation from the W.C., for Gradient 1:150 at the Male Facility.

CLASSIFICATION OF SOLID	FEMALE FACILITY		MALE FACILITY	
	Number of Solids	Prop. as Total, (%)	Number of Solids	Prop. as Total, (%)
FAECAL MATTER	361	17.8	481	49.5
FAECAL/TISSUE, (as one solid).	24	1.2	35	3.6
TOILET/TISSUE-PAPER	1581	78.0	439	45.2
SANITARY TOWELS.	30	↑	0	↑
SANITARY TOWEL DISPOSAL BAG.	3	↑	0	↑
TAMPON.	8	↑	0	↑
TAMPON TUBE.	5	↑	0	↑
HAND TOWEL.	4	3.0	14	1.6
KITCHEN TOWEL (Patterned).	2	↑	0	↑
BROWN PAPER WRAPPER.	0	↑	1	↑
CELLOPHANE WRAPPER.	5	↑	0	↑
CONFECTIONERY WRAPPER.	1	↑	0	↑
CARDBOARD.	2	↑	0	↑
WRITING PAPER.	0	↑	1	↑
TOTALS.	2026	100.0	971	100.0

FIGURE 10/34. - Summary of the Exact Material Composition of Both 'Normal' and 'Rogue'

Solids, as Contained at Evacuation from the W.C. by all Monitored

Single Flushes.

FAECAL / DESCRIPTIVE.	Male Facil.		Female Facility.		Overall
	76.81	17.60	5.59	1.13	
Proportion of faecal solids consisting of: (%)	76.81	17.60	5.59	1.13	70.03
Distinct and separate stools.	66.48	32.39	1.13	-	29.41
Cluster of small stools travelling as one	1.25"	0.29"	1.22"	1.36	0.56
Diarrhoea.	0.29"	0.5"	0.38"	0.43"	1.30
Diameter of distinct and separate stools (inches)	0.5"	2.0"	0.25"	0.5"	0.41"
Mean.	2.0"	3.02"	2.0"	2.0"	0.25"
Standard Deviation.	3.27"	1.59"	3.27"	2.57"	2.0"
Minimum.	1.0"	1.0"	0.5"	0.5"	2.90
Maximum.	8.0"	8.0"	8.0"	9.0"	1.66"
Length of distinct and separate stools (inches)	17.65	16.47	47.27	41.67	44.66
Proportion of 'cluster' solids consisting of: (%)	16.47	65.88	12.73	8.33	10.68
1/4" Diameter Spherical Components.	65.88	40.00	40.00	50.00	44.66
1/4" Diameter Components.	49.41	22.35	63.64	68.75	66.02
2 - 5 solids	22.35	28.24	10.91	6.25	8.74
6 - 9 solids.	28.24	25.45	25.45	25.00	25.24
More than 9 solids.	66.46	62.26	62.26	44.75	52.94
Proportion of all faecal solids noted as tending to float, (%).					

FIGURE 10/35. - FAECAL SOLID DESCRIPTIVE DATA, - based on all 'single' flush observations.

TOILET/TISSUE-PAPER SOLID LENGTH.	Length of Toilet/Tissue-Paper Solids, (ins.).		
	Mean	Stndrd. Dev.	Max.
'Faecal' Flushes.	7.52	3.75	3.00
	9.25	5.49	3.00
	7.53	3.25	3.00
'Non-Faecal' Flushes.	8.38	4.58	3.00
	6.73	3.68	2.00
	7.25	3.74	1.00
Irrespective of Flush Type.	7.82	4.26	1.00
	7.55	4.02	1.00
	7.22	3.74	2.00

FIGURE 10/36. - COMPARATIVE TOILET/TISSUE-PAPER SOLID LENGTH, - based on all 'single' flush observations.

TOILET/TISSUE-PAPER SOLID THICKNESS.			Proportional Rate of Occurrence, (%)				
			Very Thin	Thin	Medium	Thick	Very Thick
'Faecal' Flushes.	Male Facility.		1.49	2.61	86.57	4.48	4.85
	Female Facility.	1:150	0.95	10.48	62.86	18.09	7.62
		1:200	—	0.94	69.81	27.36	1.89
		Overall.	0.47	5.69	66.35	22.75	4.74
'Non-Faecal' Flushes.	Male Facility.		3.57	12.50	67.26	9.52	7.14
	Female Facility.	1:150	1.80	9.61	61.56	21.17	5.86
		1:200	1.00	6.43	62.00	22.43	8.14
		Overall.	1.39	7.98	61.79	21.81	7.03
Irrespective of Flush Type.	Male Facility.		2.29	6.42	79.13	6.42	5.73
	Female Facility.		1.27	7.67	62.40	21.94	6.72

FIGURE 10/37. - COMPARATIVE TOILET/TISSUE-PAPER SOLID THICKNESS, - based on all 'single' flush observations.

TOILET/TISSUE-PAPER SOLID SHAPE.			Proportional Rate of Occurrence, (%)		
			Flat	Irregular	Wedge
'Faecal' Flushes.	Male Facility.		70.15	28.73	1.12
	Female Facility.	1:150	85.71	14.29	—
		1:200	65.09	34.91	—
		Overall.	75.36	24.64	—
'Non-Faecal' Flushes.	Male Facility.		67.26	32.14	0.60
	Female Facility.	1:150	85.29	14.26	0.45
		1:200	64.86	35.14	—
		Overall.	74.82	24.96	0.22
Irrespective of Flush Type.	Male Facility.		69.04	30.05	0.92
	Female Facility.		74.89	24.92	0.19

FIGURE 10/38. - COMPARATIVE TOILET/TISSUE-PAPER SOLID SHAPE, - based on all 'single' flush observations.

			ESTIMATE OF FAECAL VOLUME PER FLUSH.	
			MEAN, (c.c.).	STANDARD DEVIATION, (c.c.).
Female Facility. Gradient 1:150 .	Flushes Grouped in Order of Occurrence. Approx. 20 \pm 1, Flushes Per Group.	Group 1.	55.10	75.51
		Group 2.	62.70	58.35
		Group 3.	115.00	95.48
		Group 4.	131.52	129.44
		Group 5.	167.82	109.87
	Overall.		106.43	104.17
Female Facility. Gradient 1:200 .	Flushes Grouped in Order of Occurrence. Approx. 20 \pm 1, Flushes Per Group.	Group 6.	143.12	98.89
		Group 7.	162.87	118.65
		Group 8.	155.43	116.26
		Group 9.	167.45	141.81
	Overall.		157.09	117.60
Male Facility. Gradient 1:150 .	Flushes Grouped in Order of Occurrence. Approx. 20 \pm 1, Flushes Per Group.	Group 10.	186.10	135.13
		Group 11.	142.05	120.45
		Group 12.	119.83	89.39
		Group 13.	118.15	102.29
		Group 14.	156.33	148.18
		Group 15.	224.89	157.95
		Group 16.	237.74	149.73
		Group 17.	202.83	133.74
		Group 18.	144.07	127.79
	Group 19.	144.59	113.92	
Overall.		166.56	131.89	

FIGURE 10/39. - Variations in 'Faecal Volume' Estimation with Chronological Grouping of 'Faecal' Flush Data.

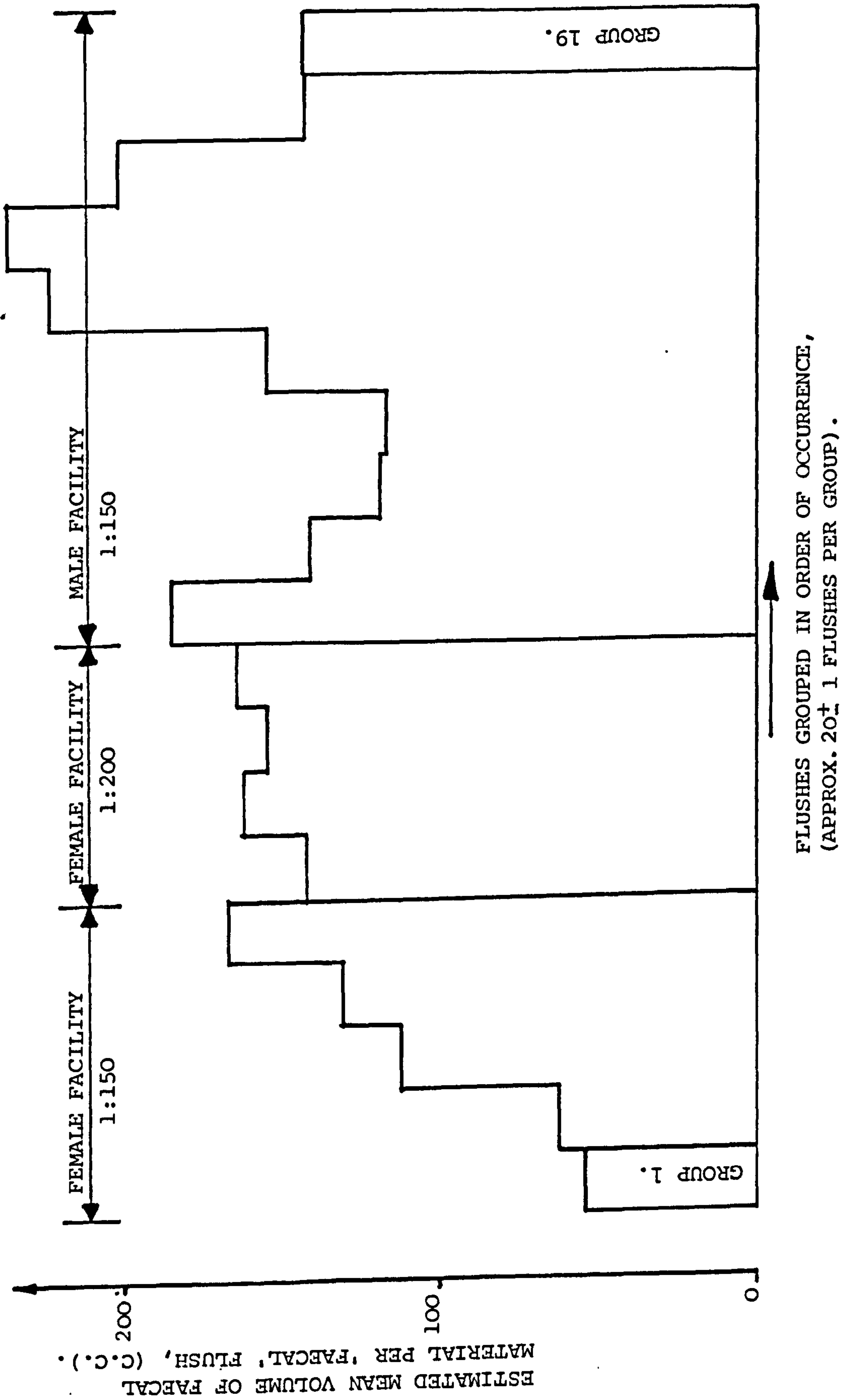

FIGURE 10/40. - Graphical Presentation of Variations in 'Faecal Volume' Estimation with Chronological Grouping of 'Faecal' Flush Data.

NUMBER OF SOLIDS EVACUATED BY THE W.C.	0	1	2	3	4	5	6	7	8	9	TOTALS
NUMBER OF FLUSHES, (Prop. as of total number of flush).	324 (32.3%)	488 (48.6%)	116 (11.6%)	39 (3.9%)	23 (2.3%)	9 (0.9%)	4 (0.4%)	1 (0.1%)			1004 (100%).
NUMBER OF FLUSHES WHICH DEPOSITED AT LEAST ONE SOLID. (Prop. as of total number of flush).	0 -	15 (1.5%)	12 (1.2%)	8 (0.8%)	7 (0.7%)	2 (0.2%)	1 (0.1%)	1 (0.1%)			46 (4.6%)
NUMBER OF FLUSHES, WHICH ENCOUNTERED AT LEAST ONE DEPOSIT. (Prop. as of total number of flushes)	16 (1.6%)	15 (1.5%)	5 (0.5%)	0 -	1 (0.1%)	0 -	0 -	0 -			37 (3.7%)
NUMBER OF FLUSHES WHICH ENCOUNTERED AND DEPOSITED AT LEAST ONE SOLID. (Prop. as of total number of flushes)	0 -	3 (0.3%)	1 (0.1%)	0 -	1 (0.1%)	0 -	0 -	0 -			5 (0.5%)
PROP. OF THOSE FLUSHES WHICH MET A STOPPAGE WHICH ALSO LEFT A DEPOSIT.	-	20%	20%	-	100%	-	-	-			13.5%
NUMBER OF FLUSHES CONTAINING AT LEAST ONE FAECAL SOLID. (Prop. as of total number of flushes).	0 -	13 (1.3%)	30 (3.0%)	26 (2.6%)	19 (1.9%)	8 (0.8%)	4 (0.4%)	1 (0.1%)			101 (10.1%)
NUMBER OF FLUSHES WHICH DID NOT ENCOUNTER ANY PREVIOUS DEPOSIT. (Prop. as of total number of flushes)	309 (30.8%)	472 (47.0%)	111 (11.1%)	39 (3.9%)	22 (2.2%)	9 (0.9%)	4 (0.4%)	1 (0.1%)			967 (96.3%)
NUMBER OF FLUSHES WHICH DID NOT ENCOUNTER ANY PREV. STOPPAGE BUT WHICH DID DEPOSIT AT LEAST ONE SOLID. (Prop. as of total number of flushes)	0 -	12 (1.2%)	11 (1.1%)	8 (0.8%)	6 (0.6%)	2 (0.2%)	1 (0.1%)	1 (0.1%)			41 (4.1%)
PROP. OF THOSE FLUSHES WHICH DID NOT MEET STOP., WHICH DEPOSITED A SOLID.	-	2.5%	9.9%	20.5%	27.3%	22.3%	25.0%	100%			4.2%

FIGURE 10/41.

DATA RELATING TO DEPOSITS ENCOUNTERED AND/OR SOLIDS DEPOSITED, AT THE FEMALE FACILITY AND AT GRADIENT 1:150 WITH RESPECT TO THE NUMBER OF SOLIDS PER FLUSH AT EVACUATION FROM THE W.C..

No. OF SOLIDS EVACUATED BY THE W.C.	1	2	3	4	5	6	7	8	9	TOTAL
No. OF FLUSHES (CONTAINING FAECAL MATERIAL).	11	29	26	18	8	4	1			97
TOTAL NUMBER OF SOLIDS INVOLVED.	11	58	78	72	40	24	7			290
No. OF SUCH FLUSHES WHICH LEFT STOPPAGES.	0	3	6	4	2	1	1			17
TOTAL NUMBER OF SOLIDS DEPOSITED.	0	3	7	5	2	3	5			25
PROP. OF ALL SOLIDS WHICH WERE DEPOSITED.	0.0%	5.2%	9.0%	6.9%	5.0%	12.5%	71.4%			8.6%
NUMBER OF FAECAL SOLIDS INVOLVED.	6	29	46	46	28	15	5			175
PROP. OF TOTAL SOLIDS WHICH WERE FAECAL.	54.5%	50.0%	59.0%	63.9%	70.0%	62.5%	71.4%			60.3%
NUMBER OF FAECAL SOLIDS DEPOSITED.	0	1	0	2	1	2	4			10
PROP. OF FAECAL SOLIDS WHICH WERE DEPOSITED.	0.0%	3.4%	0.0%	4.3%	3.6%	13.3%	80.0%			5.7%
NUMBER OF FAECAL/TISSUE SOLIDS INVOLVED.	5	3	1	0	0	0	0			9
PROP. OF TOT. WHICH WERE FAECAL/TISSUE.	45.5%	5.2%	1.3%	0.0%	0.0%	0.0%	0.0%			3.1%
No. OF FAECAL/TISSUE SOLIDS DEPOSITED.	0	1	1	0	0	0	0			2
PROP. OF FAECAL/TISSUE SOLIDS, DEPOSITED.	0.0%	33.3%	100.0%	-	-	-	-			22.2%
NUMBER OF NON-FAECAL SOLIDS INVOLVED.	-	26	31	26	12	9	2			106
PROP. OF TOTAL SOLIDS WHICH WERE NON-FAECAL.	-	44.8%	39.7%	36.1%	30.0%	37.5%	28.6%			36.6%
NUMBER OF NON-FAECAL SOLIDS DEPOSITED.	0	1	6	3	1	1	1			13
PROP. OF NON-FAECAL SOLIDS, DEPOSITED.	-	3.8%	19.4%	11.5%	8.3%	11.1%	50.0%			12.3%

FIGURE 10/42.

DATA RELATING TO THE NUMBER AND MATERIAL TYPE OF SOLIDS EVACUATED AND SOLIDS DEPOSITED, AT THE FEMALE FACILITY AND AT GRADIENT 1:150 BY THOSE 'SINGLE' 'FAECAL' FLUSHES WHICH DID NOT ENCOUNTER ANY PREVIOUS STOPPAGES.

NUMBER OF SOLIDS EVACUATED BY THE W.C.	1	2	3	4	5	6	7	8	9	TOTAL
NUMBER OF FLUSHES (WHICH CONTAINED NON-FAECAL MATERIAL ONLY).	461	82	13	4	1	0	0			561
NUMBER OF SUCH FLUSHES WHICH DEPOSITED SOLIDS.	12	8	2	2	0	0	0			24
PROPORTION OF SUCH FLUSHES WHICH DEPOSITED SOLIDS.	2.6%	9.8%	15.4%	50.0%	0.0%	-	-			4.3%
TOTAL NUMBER OF SOLIDS INVOLVED.	461	164	39	16	5	0	0			685
NUMBER OF SOLIDS DEPOSITED.	12	10	2	3	0	0	0			27
PROPORTION OF SOLIDS DEPOSITED.	2.6%	6.1%	5.1%	18.8%	0.0%	-	-			3.9%

DATA RELATING TO THE NUMBER OF SOLIDS EVACUATED AND SOLIDS DEPOSITED, AT THE FEMALE FACILITY AND AT GRADIENT 1:150 BY THOSE 'SINGLE' 'NON-FAECAL' FLUSHES WHICH DID NOT ENCOUNTER ANY PREVIOUS STOPPAGES.

FIGURE 10/43.

NUMBER OF SOLIDS EVACUATED BY THE W.C..	1	2	3	4	5	6	7	8	9	TOTAL
NUMBER OF FLUSHES (WHICH CONTAINED FAECAL MATERIAL ONLY).	6	1	1	0	0	0	0			8
NUMBER OF SUCH FLUSHES WHICH DEPOSITED SOLIDS.	0	0	0	0	0	0	0			0
PROPORTION OF SUCH FLUSHES WHICH DEPOSITED SOLIDS.	0.0%	0.0%	0.0%	-	-	-	-			0.0%
TOTAL NUMBER OF SOLIDS INVOLVED.	6	2	3	0	0	0	0			11
NUMBER OF SOLIDS DEPOSITED.	0	0	0	0	0	0	0			0
PROPORTION OF SOLIDS DEPOSITED.	0.0%	0.0%	0.0%	-	-	-	-			0.0%

DATA RELATING TO THE NUMBER OF SOLIDS EVACUATED AND SOLIDS DEPOSITED AT THE FEMALE FACILITY AND AT GRADIENT 1:150 BY THOSE 'SINGLE' 'FAECAL' FLUSHES WHICH CONTAINED FAECAL MATERIAL ONLY, AND WHICH DID NOT ENCOUNTER ANY PREVIOUS STOPPAGES.

FIGURE 10/44.

NUMBER OF SOLIDS EVACUATED BY THE W.C.	0	1	2	3	4	5	6	7	8	9	TOTALS
NUMBER OF FLUSHES, (Prop. as of total number of flush).	329 (33.1%)	479 (48.1%)	109 (11.0%)	30 (3.0%)	20 (2.0%)	19 (1.9%)	6 (0.6%)	1 (0.1%)	2 (0.2%)		995 (100%)
NUMBER OF FLUSHES WHICH DEPOSITED AT LEAST ONE SOLID. (Prop. as of total number of flush).	3 (0.3%)	41 (4.1%)	16 (1.6%)	12 (1.2%)	8 (0.8%)	8 (0.8%)	2 (0.2%)	0 -	1 (0.1%)		91 (9.1%)
NUMBER OF FLUSHES, WHICH ENCOUNTERED AT LEAST ONE DEPOSIT. (Prop. as of total number of flushes)	24 (2.4%)	39 (3.9%)	7 (0.7%)	3 (0.3%)	3 (0.3%)	2 (0.2%)	1 (0.1%)	0 -	0 -		79 (7.9%)
NUMBER OF FLUSHES WHICH ENCOUNTERED AND DEPOSITED AT LEAST ONE SOLID. (Prop. as of total number of flushes)	3 (0.3%)	7 (0.7%)	2 (0.2%)	3 (0.3%)	2 (0.2%)	1 (0.1%)	1 (0.1%)	0 -	0 -		19 (1.9%)
PROP. OF THOSE FLUSHES WHICH MET A STOPPAGE WHICH ALSO LEFT A DEPOSIT.	12.5%	17.9%	28.6%	100%	66.7%	50.0%	100%	-	-		24.1%
NUMBER OF FLUSHES CONTAINING AT LEAST ONE FAECAL SOLID. (Prop. as of total number of flushes).	0 -	7 (0.7%)	7 (0.7%)	20 (2.0%)	18 (1.8%)	18 (1.8%)	6 (0.6%)	1 (0.1%)	2 (0.2%)		79 (7.9%)
NUMBER OF FLUSHES WHICH DID NOT ENCOUNTER ANY PREVIOUS DEPOSIT. (Prop. as of total number of flushes)	305 (30.7%)	440 (44.2%)	102 (10.3%)	27 (2.7%)	17 (1.7%)	17 (1.7%)	5 (0.5%)	1 (0.1%)	2 (0.2%)		916 (92.1%)
NUMBER OF FLUSHES WHICH DID NOT ENCOUNTER ANY PREV. STOPPAGE BUT WHICH DID DEPOSIT AT LEAST ONE SOLID. (Prop. as of total number of flushes)	0 -	34 (3.4%)	14 (1.4%)	9 (0.9%)	6 (0.6%)	7 (0.7%)	1 (0.1%)	0 -	1 (0.1%)		72 (7.2%)
PROP. OF THOSE FLUSHES WHICH DID NOT MEET STOP. WHICH DEPOSITED A SOLID.	-	7.7%	13.7%	33.3%	35.3%	41.2%	20%	-	50%		7.9%

FIGURE 10/45.

DATA RELATING TO DEPOSITS ENCOUNTERED AND/OR SOLIDS DEPOSITED, AT THE FEMALE FACILITY AND AT GRADIENT 1:200 WITH REPECT TO THE NUMBER OF SOLIDS PER FLUSH AT EVACUATION FROM THE W.C..

No. OF SOLIDS EVACUATED BY THE W.C.	1	2	3	4	5	6	7	8	9	TOTAL
No. OF FLUSHES (CONTAINING FAECAL MATERIAL).	7	7	17	16	17	5	1	2		72
TOTAL NUMBER OF SOLIDS INVOLVED.	7	14	51	64	85	30	7	16		274
No. OF SUCH FLUSHES WHICH LEFT STOPPAGES.	3	2	8	6	7	1	0	1		28
TOTAL NUMBER OF SOLIDS DEPOSITED.	3	3	19	13	21	6	0	6		71
PROP. OF ALL SOLIDS WHICH WERE DEPOSITED.	42.9%	21.4%	37.3%	20.3%	24.7%	20.0%	0.0%	37.5%		25.9%
NUMBER OF FAECAL SOLIDS INVOLVED.	3	7	27	42	54	23	6	9		171
PROP. OF TOTAL SOLIDS WHICH WERE FAECAL.	42.9%	50.0%	52.9%	65.6%	63.5%	76.7%	85.7%	56.3%		62.4%
NUMBER OF FAECAL SOLIDS DEPOSITED.	0	1	8	5	11	5	0	4		34
PROP. OF FAECAL SOLIDS WHICH WERE DEPOSITED.	0.0%	14.3%	29.6%	11.9%	20.4%	21.7%	0.0%	44.4%		19.9%
NUMBER OF FAECAL/TISSUE SOLIDS INVOLVED.	4	1	2	1	1	0	0	1		10
PROP. OF TOT. WHICH WERE FAECAL/TISSUE.	57.1%	7.1%	3.9%	1.6%	1.2%	-	-	6.2%		3.6%
No. OF FAECAL/TISSUE SOLIDS DEPOSITED.	3	1	0	0	0	0	0	1		5
PROP. OF FAECAL/TISSUE SOLIDS, DEPOSITED.	75%	100%	0.0%	0.0%	0.0%	-	-	100.0%		50.0%
NUMBER OF NON-FAECAL SOLIDS INVOLVED.	0	6	22	21	30	7	1	6		93
PROP. OF TOTAL SOLIDS WHICH WERE NON-FAECAL.	0.0%	42.9%	43.1%	32.8%	35.3%	23.3%	14.3%	37.5%		33.9%
NUMBER OF NON-FAECAL SOLIDS DEPOSITED.	0	1	11	8	10	1	0	1		32
PROP. OF NON-FAECAL SOLIDS, DEPOSITED.	-	16.7%	50.0%	38.1%	33.3%	14.3%	0.0%	16.7%		34.4%

FIGURE 10/46.
 DATA RELATING TO THE NUMBER AND MATERIAL TYPE OF SOLIDS EVACUATED AND SOLIDS DEPOSITED, AT THE FEMALE FACILITY AND AT GRADIENT 1:200 BY THOSE 'SINGLE' 'FAECAL' FLUSHES WHICH DID NOT ENCOUNTER ANY PREVIOUS STOPPAGES.

NUMBER OF SOLIDS EVACUATED BY THE W.C.	1	2	3	4	5	6	7	8	9	TOTAL
NUMBER OF FLUSHES (WHICH CONTAINED NON-FAECAL MATERIAL ONLY).	433	95	10	1	0	0	0	0		539
NUMBER OF SUCH FLUSHES WHICH DEPOSITED SOLIDS.	31	12	1	0	0	0	0	0		44
PROPORTION OF SUCH FLUSHES WHICH DEPOSITED SOLIDS.	7.2%	12.6%	10.0%	0.0%	-	-	-	-		8.2%
TOTAL NUMBER OF SOLIDS INVOLVED.	433	190	30	4	0	0	0	0		657
NUMBER OF SOLIDS DEPOSITED.	31	20	1	0	0	0	0	0		52
PROPORTION OF SOLIDS DEPOSITED.	7.2%	10.5%	3.3%	0.0%	-	-	-	-		7.9%

FIGURE 10/47.
DATA RELATING TO THE NUMBER OF SOLIDS EVACUATED AND SOLIDS DEPOSITED, AT THE FEMALE FACILITY AND AT GRADIENT 1:200 BY THOSE 'SINGLE' 'NON-FAECAL' FLUSHES WHICH DID NOT ENCOUNTER ANY PREVIOUS STOPPAGES.

NUMBER OF SOLIDS EVACUATED BY THE W.C..	1	2	3	4	5	6	7	8	9	TOTAL
NUMBER OF FLUSHES (WHICH CONTAINED FAECAL MATERIAL ONLY).	3	0	1	1	0	0	0	0		5
NUMBER OF SUCH FLUSHES WHICH DEPOSITED SOLIDS.	0	0	0	0	0	0	0	0		0
PROPORTION OF SUCH FLUSHES WHICH DEPOSITED SOLIDS.	0.0%	-	0.0%	0.0%	-	-	-	-		0.0%
TOTAL NUMBER OF SOLIDS INVOLVED.	3	0	3	4	0	0	0	0		10
NUMBER OF SOLIDS DEPOSITED.	0	0	0	0	0	0	0	0		0
PROPORTION OF SOLIDS DEPOSITED.	0.0%	-	0.0%	0.0%	-	-	-	-		0.0%

FIGURE 10/48.
DATA RELATING TO THE NUMBER OF SOLIDS EVACUATED AND SOLIDS DEPOSITED AT THE FEMALE FACILITY AND AT GRADIENT 1:200 BY THOSE 'SINGLE' 'FAECAL' FLUSHES WHICH CONTAINED FAECAL MATERIAL ONLY, AND WHICH DID NOT ENCOUNTER ANY PREVIOUS STOPPAGES.

NUMBER OF SOLIDS EVACUATED BY THE W.C	0	1	2	3	4	5	6	7	8	9	TOTALS
NUMBER OF FLUSHES, (Prop. as of total number of flush).	180 (36.1%)	79 (15.6%)	84 (16.8%)	49 (9.8%)	38 (7.6%)	27 (5.4%)	22 (4.4%)	11 (2.2%)	8 (1.6%)	2 (0.4%)	499 (100%)
NUMBER OF FLUSHES WHICH DEPOSITED AT LEAST ONE SOLID. (Prop. as of total number of flush).	8 (1.6%)	9 (1.8%)	30 (6.0%)	16 (3.2%)	14 (2.8%)	7 (1.4%)	7 (1.4%)	6 (1.2%)	5 (1.0%)	1 (0.2%)	103 (20.6%)
NUMBER OF FLUSHES, WHICH ENCOUNTERED AT LEAST ONE DEPOSIT. (Prop. as of total number of flushes)	37 (7.4%)	20 (4.0%)	19 (3.8%)	11 (2.2%)	3 (0.6%)	1 (0.2%)	1 (0.2%)	2 (0.4%)	0 -	0 -	94 (18.8%)
NUMBER OF FLUSHES WHICH ENCOUNTERED AND DEPOSITED AT LEAST ONE SOLID. (Prop. as of total number of flushes)	8 (1.6%)	5 (1.0%)	10 (2.0%)	3 (0.6%)	1 (0.2%)	0 -	1 (0.2%)	1 (0.2%)	0 -	0 -	29 (5.8%)
PROP. OF THOSE FLUSHES WHICH MET A STOPPAGE WHICH ALSO LEFT A DEPOSIT.	21.6%	25.0%	52.6%	27.3%	33.3%	0.0%	100.0%	50.0%	-	-	30.9%
NUMBER OF FLUSHES CONTAINING AT LEAST ONE FAECAL SOLID. (Prop. as of total number of flushes).	0 -	13 (2.6%)	49 (9.8%)	40 (8.0%)	35 (7.0%)	27 (5.4%)	22 (4.4%)	10 (2.0%)	8 (1.6%)	2 (0.4%)	206 (41.3%)
NUMBER OF FLUSHES WHICH DID NOT ENCOUNTER ANY PREVIOUS DEPOSIT. (Prop. as of total number of flushes)	143 (28.7%)	58 (11.6%)	65 (13.0%)	38 (7.6%)	35 (7.0%)	26 (5.2%)	21 (4.2%)	9 (1.8%)	8 (1.6%)	2 (0.4%)	405 (81.2%)
NUMBER OF FLUSHES WHICH DID NOT ENCOUNTER ANY PREV. STOPPAGE BUT WHICH DID DEPOSIT AT LEAST ONE SOLID. (Prop. as of total number of flushes)	0 -	4 (0.8%)	20 (4.0%)	13 (2.6%)	13 (2.6%)	7 (1.4%)	6 (1.2%)	5 (1.0%)	5 (1.0%)	1 (0.2%)	74 (14.8%)
PROP. OF THOSE FLUSHES WHICH DID NOT MEET STOP., WHICH DEPOSITED A SOLID.	-	6.9%	30.8%	34.2%	37.1%	26.9%	28.6%	55.6%	62.5%	50.0%	18.3%

FIGURE 10/49.

DATA RELATING TO DEPOSITS ENCOUNTERED AND/OR SOLIDS DEPOSITED, AT THE MALE FACILITY AND AT GRADIENT 1:150 WITH RESPECT TO THE NUMBER OF SOLIDS PER FLUSH AT EVACUATION FROM THE W.C..

No. OF SOLIDS EVACUATED BY THE W.C.	1	2	3	4	5	6	7	8	9	TOTAL
No. OF FLUSHES (CONTAINING FAECAL MATERIAL).	10	38	31	32	26	21	8	8	2	176
TOTAL NUMBER OF SOLIDS INVOLVED.	10	76	93	128	130	126	56	64	18	701
No. OF SUCH FLUSHES WHICH LEFT STOPPAGES.	1	12	12	12	7	6	5	5	1	61
TOTAL NUMBER OF SOLIDS DEPOSITED.	1	15	24	25	20	17	20	26	4	152
PROP. OF ALL SOLIDS WHICH WERE DEPOSITED.	10.0%	19.7%	25.8%	19.5%	15.4%	13.5%	35.7%	40.6%	22.2%	21.7%
NUMBER OF FAECAL SOLIDS INVOLVED.	4	34	46	87	85	90	40	37	12	435
PROP. OF TOTAL SOLIDS WHICH WERE FAECAL.	40.0%	44.7%	49.5%	68.0%	65.4%	71.4%	71.4%	57.8%	66.7%	62.1%
NUMBER OF FAECAL SOLIDS DEPOSITED.	0	3	9	9	7	6	9	9	1	53
PROP. OF FAECAL SOLIDS WHICH WERE DEPOSITED.	0.0%	8.8%	19.6%	10.3%	8.2%	6.7%	22.5%	24.3%	8.3%	12.2%
NUMBER OF FAECAL/TISSUE SOLIDS INVOLVED.	6	12	7	1	1	0	2	1	0	30
PROP. OF TOT. WHICH WERE FAECAL/TISSUE.	60.0%	15.8%	7.5%	0.8%	0.8%	0.0%	3.6%	1.6%	0.0%	4.3%
No. OF FAECAL/TISSUE SOLIDS DEPOSITED.	1	2	4	1	0	0	1	1	0	10
PROP. OF FAECAL/TISSUE SOLIDS, DEPOSITED.	16.7%	16.7%	57.1%	100.0%	0.0%	-	50.0%	100.0%	-	33.3%
NUMBER OF NON-FAECAL SOLIDS INVOLVED.	0	30	40	40	44	36	14	26	6	236
PROP. OF TOTAL SOLIDS WHICH WERE NON-FAECAL.	-	39.5%	43.0%	31.2%	33.8%	28.6%	25.0%	40.6%	33.3%	33.7%
NUMBER OF NON-FAECAL SOLIDS DEPOSITED.	0	10	11	15	13	11	10	16	3	89
PROP. OF NON-FAECAL SOLIDS, DEPOSITED.	-	33.3%	27.5%	37.5%	29.5%	30.6%	71.4%	61.5%	50.0%	37.7%

DATA RELATING TO THE NUMBER AND MATERIAL TYPE OF SOLIDS EVACUATED AND SOLIDS DEPOSITED, AT THE MALE FACILITY AND AT GRADIENT 1:150 BY THOSE 'SINGLE' 'FAECAL' FLUSHES WHICH DID NOT ENCOUNTER ANY PREVIOUS STOPPAGES.

FIGURE 10/50.

NUMBER OF SOLIDS EVACUATED BY THE W.C.	1	2	3	4	5	6	7	8	9	TOTAL
NUMBER OF FLUSHES (WHICH CONTAINED NON-FAECAL MATERIAL ONLY).	48	27	7	3	0	0	1			86
NUMBER OF SUCH FLUSHES WHICH DEPOSITED SOLIDS.	3	8	1	1	0	0	0			13
PROPORTION OF SUCH FLUSHES WHICH DEPOSITED SOLIDS.	6.3%	29.6%	14.3%	33.3%	-	-	0.0%			15.1%
TOTAL NUMBER OF SOLIDS INVOLVED.	48	54	21	12	0	0	7			142
NUMBER OF SOLIDS DEPOSITED.	3	16	12	4	0	0	0			25
PROPORTION OF SOLIDS DEPOSITED.	6.3%	29.6%	57.1%	33.3%	-	-	0.0%			17.6%

FIGURE 10/51. DATA RELATING TO THE NUMBER OF SOLIDS EVACUATED AND SOLIDS DEPOSITED, AT THE MALE FACILITY AND AT GRADIENT 1:150 BY THOSE 'SINGLE' 'NON-FAECAL' FLUSHES WHICH DID NOT ENCOUNTER ANY PREVIOUS STOPPAGES.

NUMBER OF SOLIDS EVACUATED BY THE W.C..	1	2	3	4	5	6	7	8	9	TOTAL
NUMBER OF FLUSHES (WHICH CONTAINED FAECAL MATERIAL ONLY).	4	3	2	5	1	1	0			16
NUMBER OF SUCH FLUSHES WHICH DEPOSITED SOLIDS.	0	1	2	1	0	0	0			4
PROPORTION OF SUCH FLUSHES WHICH DEPOSITED SOLIDS.	0.0%	33.3%	100.0%	20.0%	0.0%	0.0%	-			25.0%
TOTAL NUMBER OF SOLIDS INVOLVED.	4	6	6	20	5	6	0			47
NUMBER OF SOLIDS DEPOSITED.	0	1	3	1	0	0	0			5
PROPORTION OF SOLIDS DEPOSITED.	0.0%	16.7%	50.0%	5.0%	0.0%	0.0%	-			10.6%

FIGURE 10/52. DATA RELATING TO THE NUMBER OF SOLIDS EVACUATED AND SOLIDS DEPOSITED AT THE MALE FACILITY AND AT GRADIENT 1:150 BY THOSE 'SINGLE' 'FAECAL' FLUSHES WHICH CONTAINED FAECAL MATERIAL ONLY, AND WHICH DID NOT ENCOUNTER ANY PREVIOUS STOPPAGES.

			PROPORTION OF THOSE SOLIDS CONTAINED AT EVACUATION WHICH WERE DEPOSITED IN THE MONITORED LENGTH OF PIPEWORK, (%)			PROPORTION OF THOSE SOLIDS ENCOUNTERED ALREADY IN THE PIPEWORK WHICH WERE NOT CLEARED, (%)		
			MALE FACILITY		FEMALE FACILITY			
			GRAD. 1:150	GRAD. 1:150	GRAD. 1:200	GRAD. 1:150	GRAD. 1:150	GRAD. 1:200
ALL SINGLE FLUSHES.	FLUSHES WHICH DID NOT MEET ANY PREVIOUS STOPS IN PIPE.	TOTAL SOLIDS.	21.0	5.3	13.2			
		FAECAL SOLIDS	12.2	5.7	19.9			
		FAECAL/TISSUE SLDS.	33.3	22.2	50.0			
		NON-FAECAL SOLIDS.	30.2	5.1	11.2			
	FLUSHES WHICH DID MEET PREVIOUS DEPOSITS IN PIPE.	TOTAL SOLIDS.	32.8	16.7	32.2	20.0	2.4	16.6
		FAECAL SOLIDS	28.3	0.0	33.3	25.7	25.0	23.3
		FAECAL/TISSUE SLDS	20.0	25.0	100.0	15.4	0.0	45.5
		NON-FAECAL SOLIDS.	36.4	17.4	31.2	17.6	0.0	10.7
'FAECAL' FLUSHES.	FLUSHES WHICH DID NOT MEET ANY PREVIOUS STOPS IN PIPE.	TOTAL SOLIDS.	21.7	8.6	25.9			
		FAECAL SOLIDS.	12.2	5.7	19.9			
		FAECAL/TISSUE SLDS	33.3	22.2	50.0			
		NON-FAECAL SOLIDS.	37.7	12.3	34.4			
	FLUSHES WHICH DID MEET PREVIOUS DEPOSITS IN PIPE.	TOTAL SOLIDS.	29.2	25.0	64.3	28.1	0.0	20.0
		FAECAL SOLIDS.	28.3	0.0	33.3	43.5	-	50.0
		FAECAL/TISSUE SLDS	20.0	25.0	100.0	0.0	-	-
		NON-FAECAL SOLIDS.	31.6	100.0	86.7	21.1	0.0	12.5
'NON-FAECAL' FLUSHES.	FLUSHES WHICH DID NOT MEET ANY PREVIOUS STOPS IN PIPE.	TOTAL SOLIDS.	17.6	3.9	7.9			
		FAECAL SOLIDS.	-	-	-			
		FAECAL/TISSUE SLDS	-	-	-			
		NON-FAECAL SOLIDS.	17.6	3.9	7.9			
	FLUSHES WHICH DID MEET PREVIOUS DEPOSITS IN PIPE.	TOTAL SOLIDS.	41.0	13.6	17.7	19.4	5.3	18.4
		FAECAL SOLIDS.	-	-	-	22.7	50.0	34.8
		FAECAL/TISSUE SLDS	-	-	-	0.0	-	37.5
		NON-FAECAL SOLIDS.	41.0	13.6	17.7	20.9	0.0	10.4
'WATER ONLY' FLUSHES.	FLUSHES WHICH DID NOT MEET ANY PREVIOUS STOPS IN PIPE.	TOTAL SOLIDS.						
		FAECAL SOLIDS.						
		FAECAL/TISSUE SLDS						
		NON-FAECAL SOLIDS.						
	FLUSHES WHICH DID MEET PREVIOUS DEPOSITS IN PIPE.	TOTAL SOLIDS.				15.2	0.0	12.2
		FAECAL SOLIDS.				13.8	0.0	5.6
		FAECAL/TISSUE SLDS				66.7	0.0	66.7
		NON-FAECAL SOLIDS.				13.4	0.0	10.7

FIGURE 10/53. - Summary of Waste Solid Deposition.

NUMBER OF SOLIDS PER FLUSH		2	3	4	5	6	7	8
PROPORTION OF SOLIDS WHICH WERE OF FAECAL MATERIAL, (%) (WITH RESPECT TO THE ORDER OF ARRIVAL OF SOLIDS.)	1st SOLID	83.8	90.9	94.4	96.1	100.0	50.0	100.0
	2nd SOLID	17.6	61.4	86.1	92.3	90.0	100.0	100.0
	3rd SOLID		10.2	51.4	65.4	70.0	100.0	100.0
	4th SOLID			19.4	46.1	50.0	100.0	50.0
	5th SOLID				23.1	50.0	100.0	50.0
	6th SOLID					40.0	100.0	50.0
	7th SOLID						0.0	0.0
	8th SOLID							0.0

FIGURE 10/54. - RELATIVE POSITION OF FAECAL SOLIDS IN FEMALE FACILITY 'FAECAL' FLUSHES, - AS REGARDS THE ORDER OF ARRIVAL OF SOLIDS INTO THE DISCHARGE PIPEWORK.

NUMBER OF SOLIDS PER FLUSH		2	3	4	5	6	7	8	9
PROPORTION OF SOLIDS WHICH WERE OF FAECAL MATERIAL, (%) (WITH RESEPCT TO THE ORDER OF ARRIVAL OF SOLIDS).	1st SOLID	83.3	93.2	96.7	88.5	95.2	100.0	100.0	100.0
	2nd SOLID	13.1	50.0	86.7	90.4	100.0	100.0	100.0	100.0
	3rd SOLID		5.4	65.0	80.0	95.2	100.0	100.0	100.0
	4th SOLID			3.3	48.1	71.4	70.0	75.0	100.0
	5th SOLID				7.7	42.9	50.0	68.8	100.0
	6th SOLID					4.8	45.0	25.0	100.0
	7th SOLID						5.0	0.0	0.0
	8th SOLID							0.0	0.0
	9th SOLID								0.0

FIGURE 10/55. - RELATIVE POSITION OF FAECAL SOLIDS IN MALE FACILITY 'FAECAL' FLUSHES, - AS REGARDS THE ORDER OF ARRIVAL OF SOLIDS INTO THE DISCHARGE PIPEWORK.

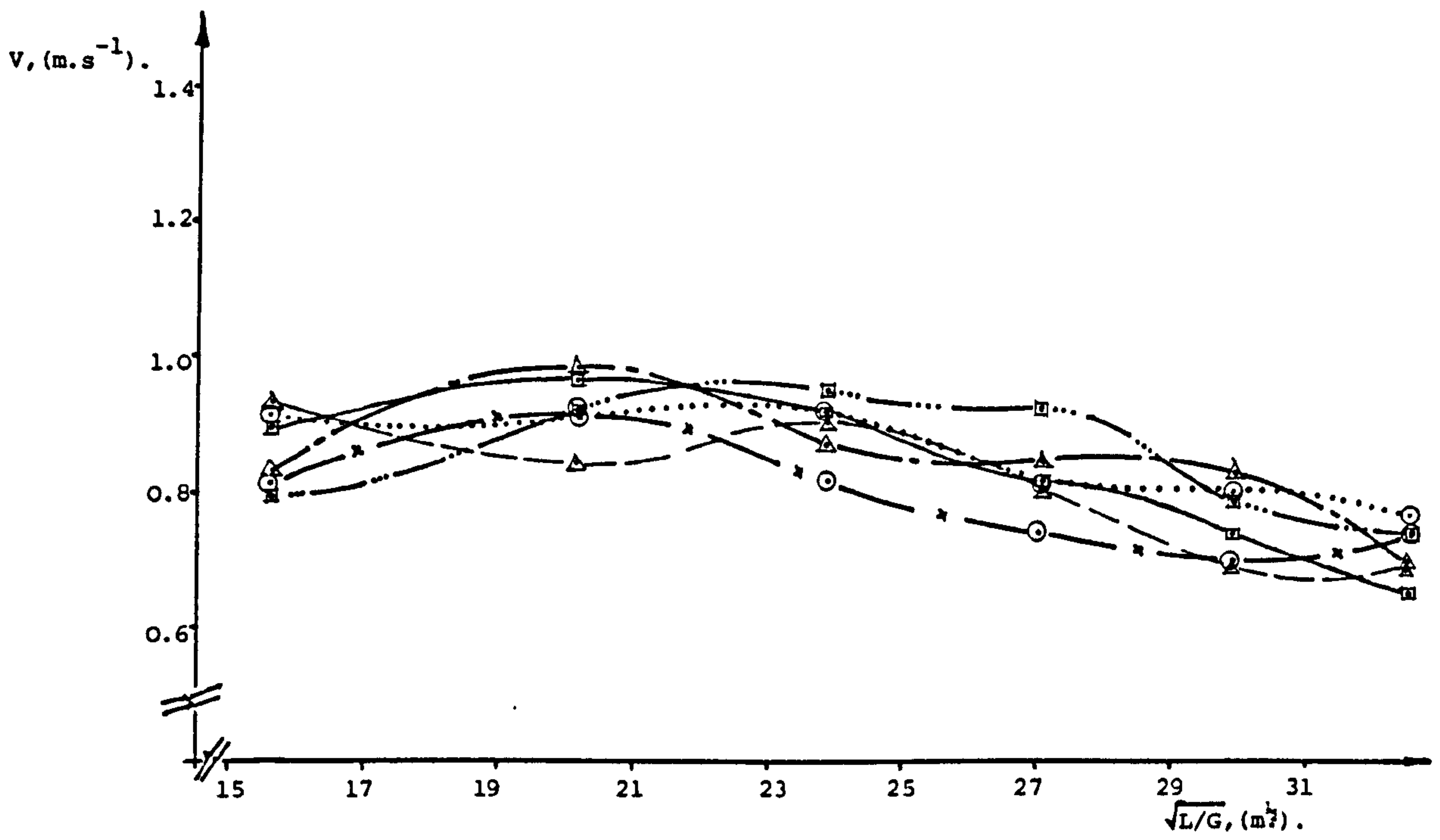

FIGURE 10/56. - INDIVIDUAL SOLID VELOCITY PROFILES OF A RANGE OF 'FASTIDIA MINI-PADS', AS RECORDED IN THE LABORATORY AT GRADIENT 1:80.

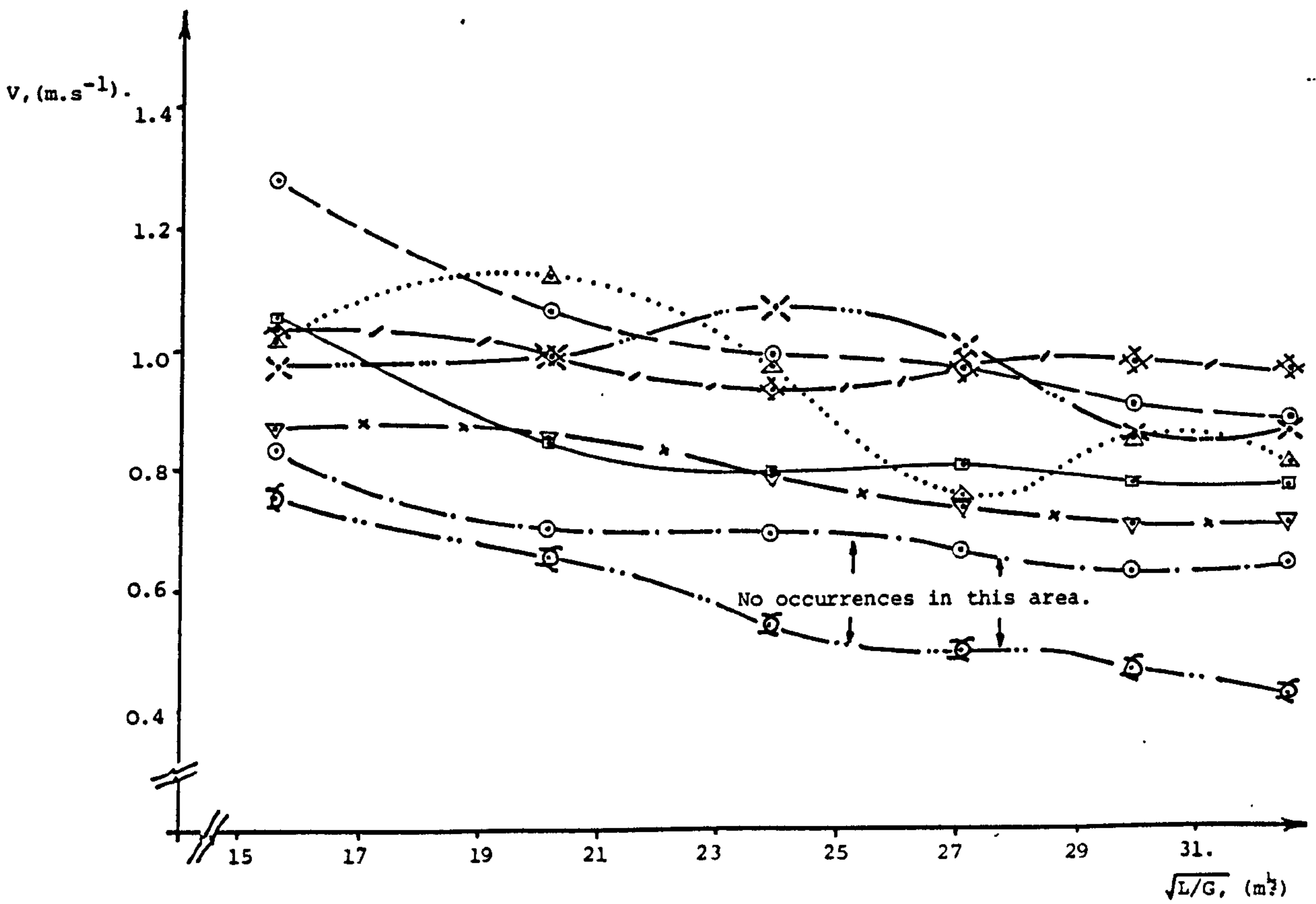

FIGURE 10/57. - INDIVIDUAL SOLID VELOCITY PROFILES OF A RANGE OF 'JOHNSON & JOHNSON PANTY SHIELDS', AS RECORDED IN THE LABORATORY AT GRADIENT 1:80.

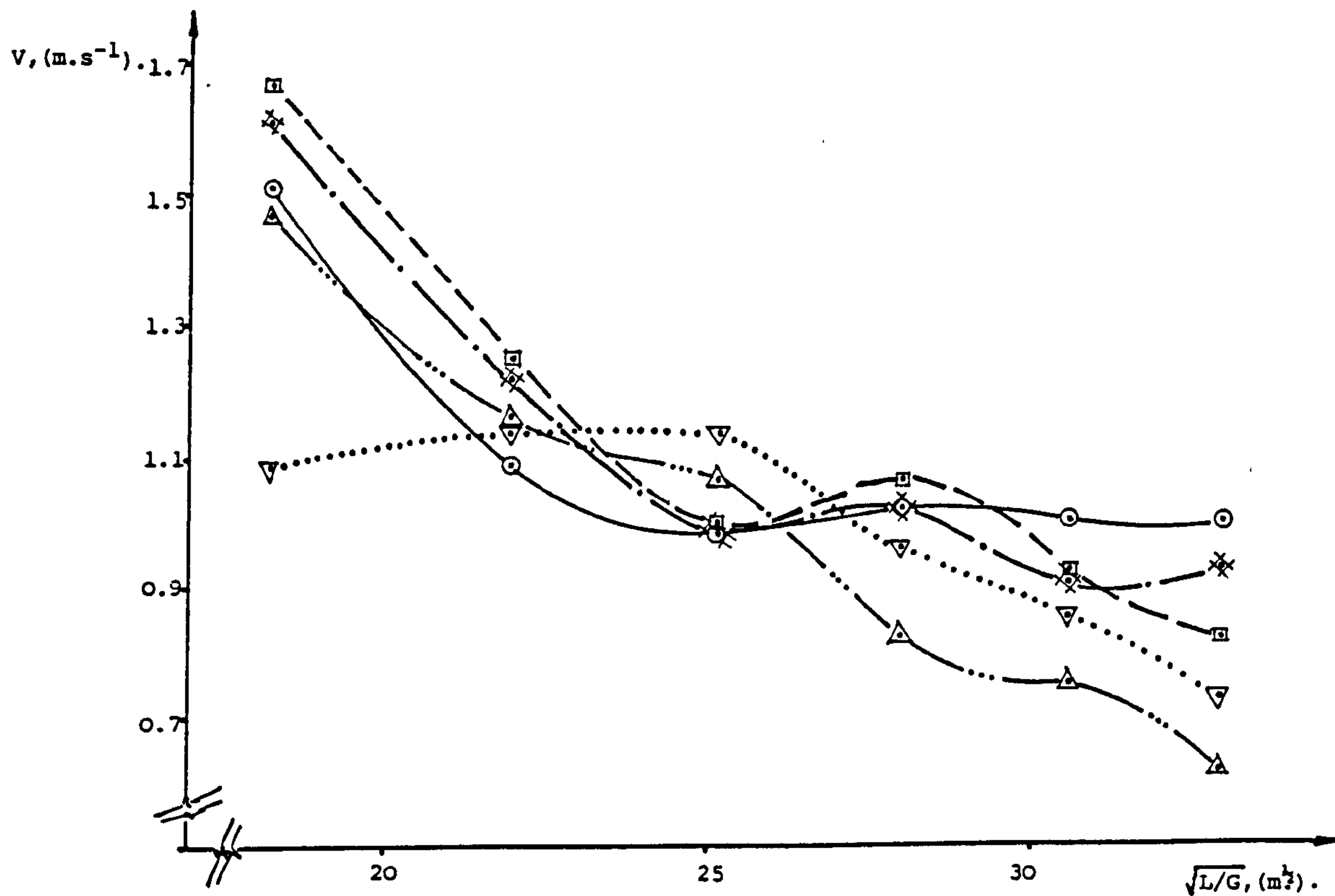

FIGURE 10/58. - INDIVIDUAL SOLID VELOCITY PROFILES OF A RANGE OF 'FASTIDIA MINI-PADS', AS RECORDED AT THE MALE FACILITY AT GRADIENT 1:150, (W.C.5).

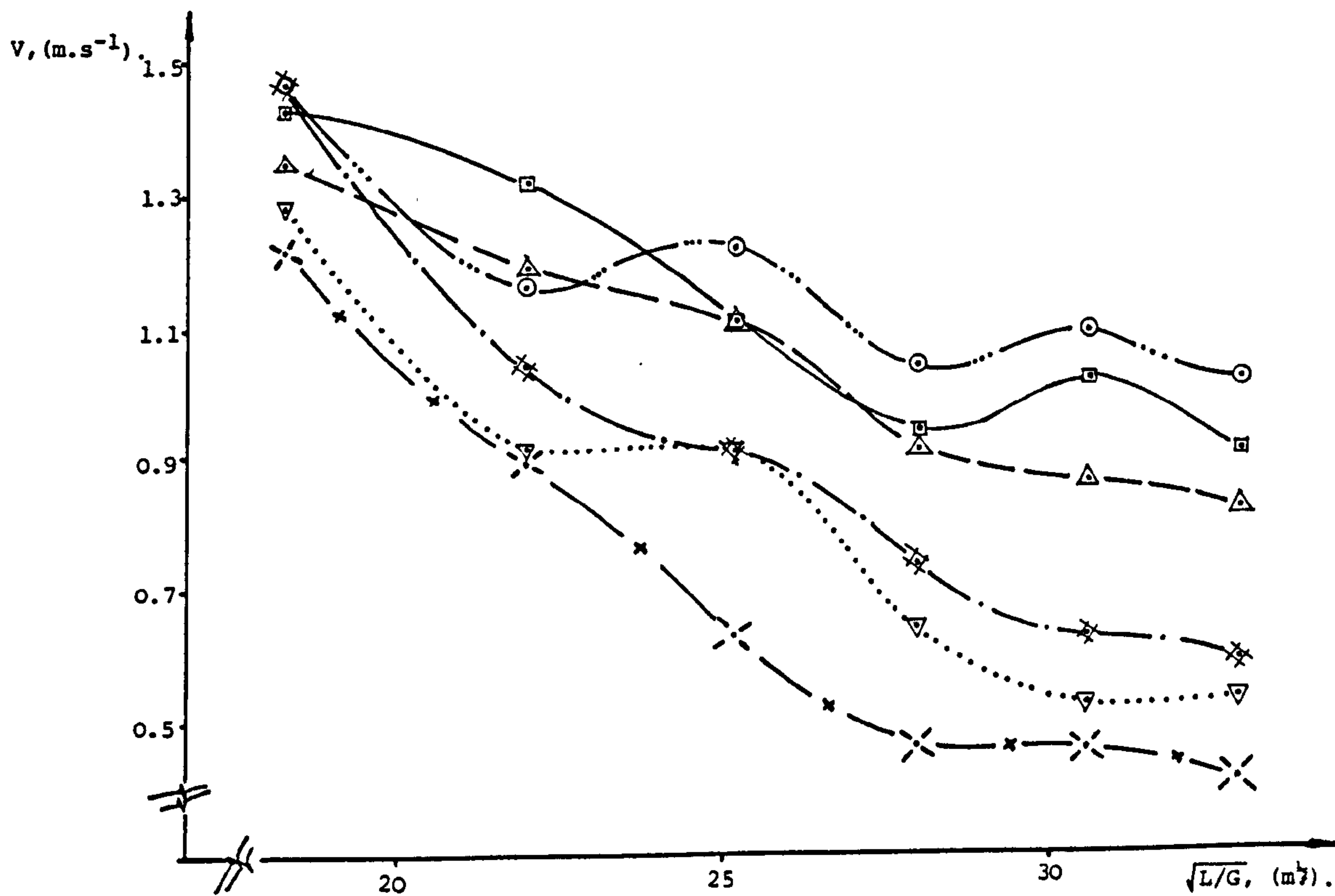

FIGURE 10/59. - INDIVIDUAL SOLID VELOCITY PROFILES OF A RANGE OF 'JOHNSON & JOHNSON PANTY SHIELDS', AS RECORDED AT THE MALE FACILITY AT GRADIENT 1:150, (W.C.5).

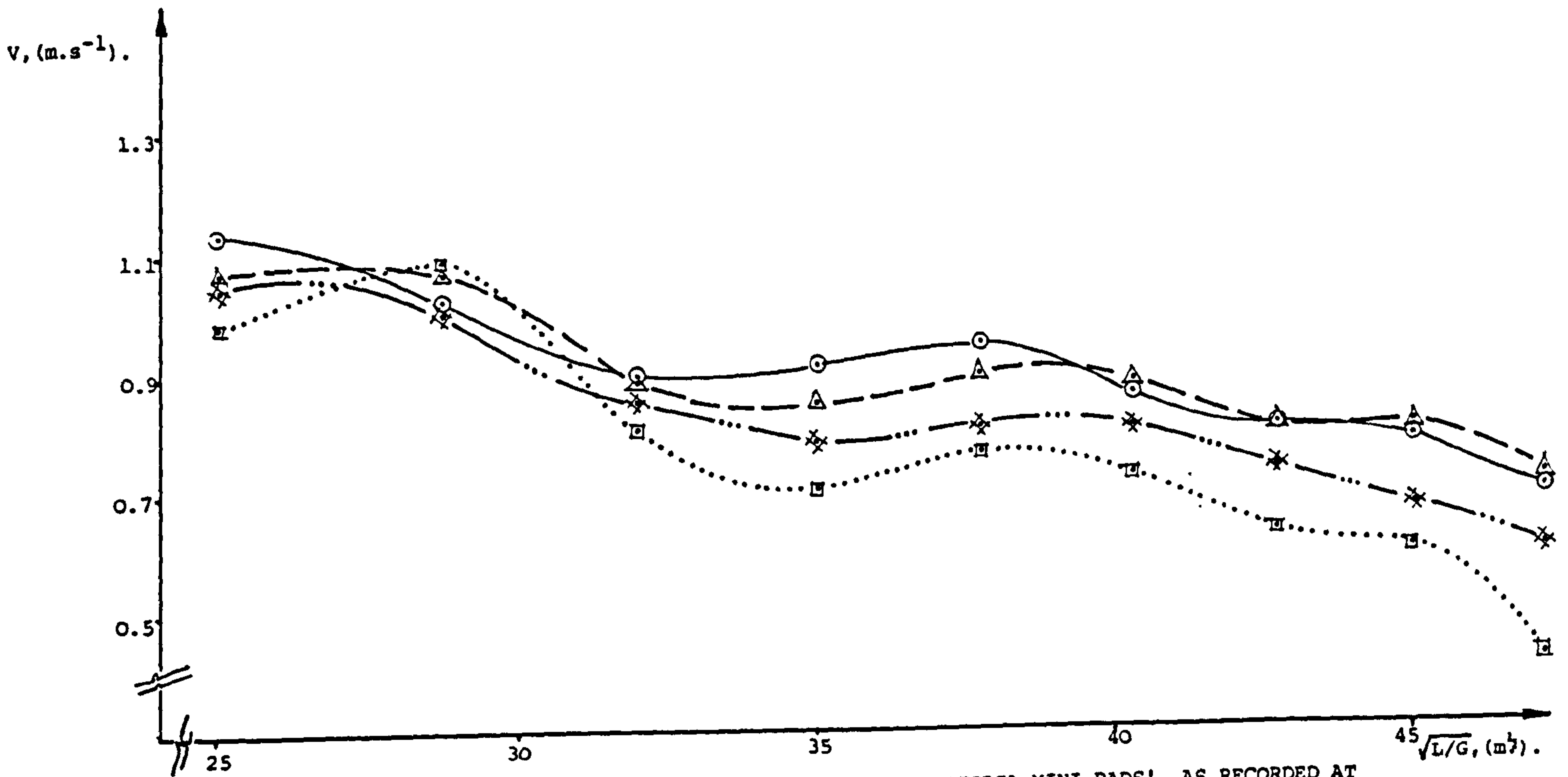

FIGURE 10/60, - INDIVIDUAL SOLID VELOCITY PROFILES OF A RANGE OF 'FASTIDIA MINI-PADS', AS RECORDED AT THE MALE FACILITY AT GRADIENT 1:200, (W.C.3).

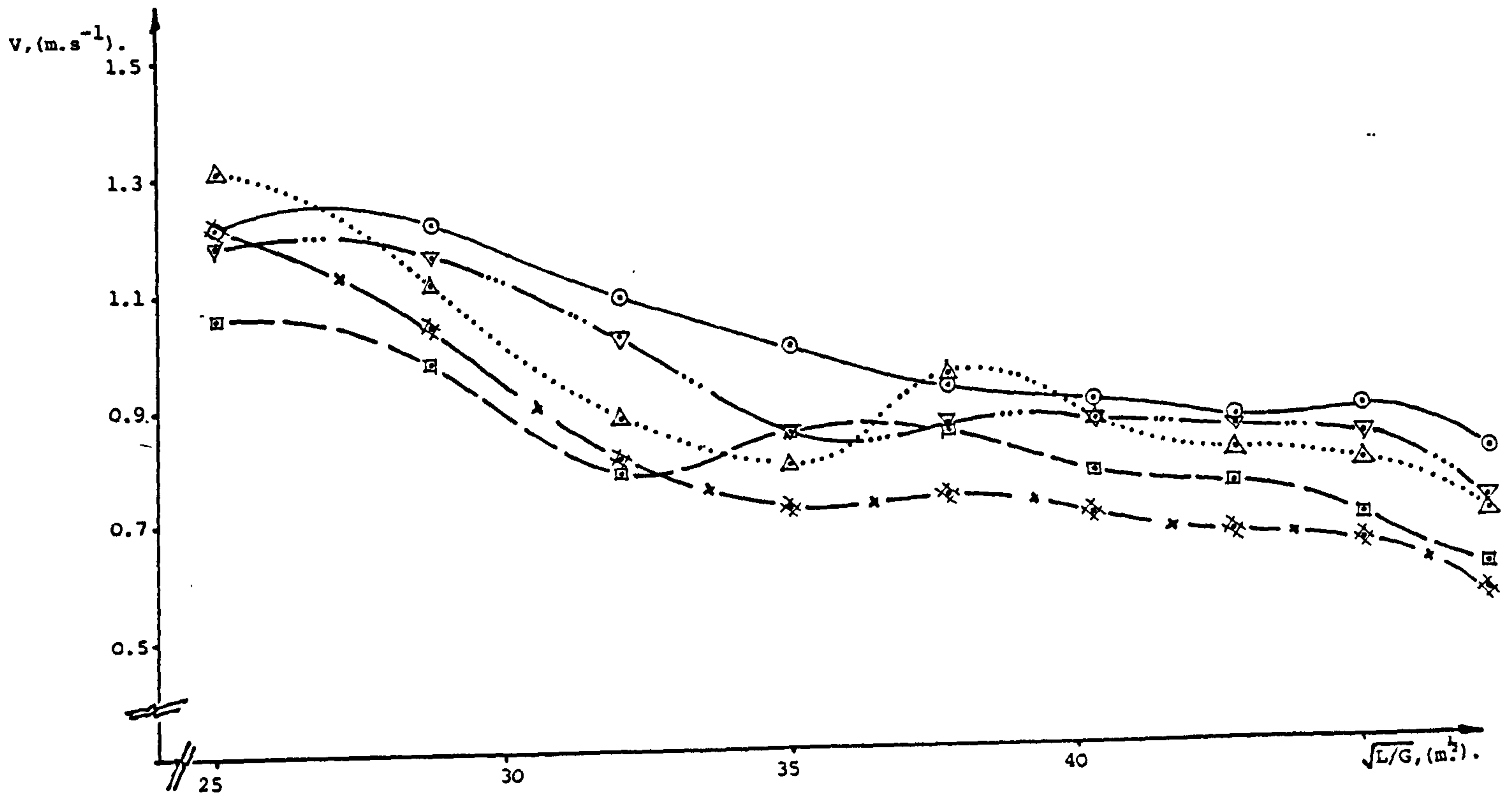

FIGURE 10/61. - INDIVIDUAL SOLID VELOCITY PROFILES OF A RANGE OF 'JOHNSON & JOHNSON PANTY SHIELDS', AS RECORDED AT THE FEMALE FACILITY AT GRADIENT 1:200, (W.C.3).

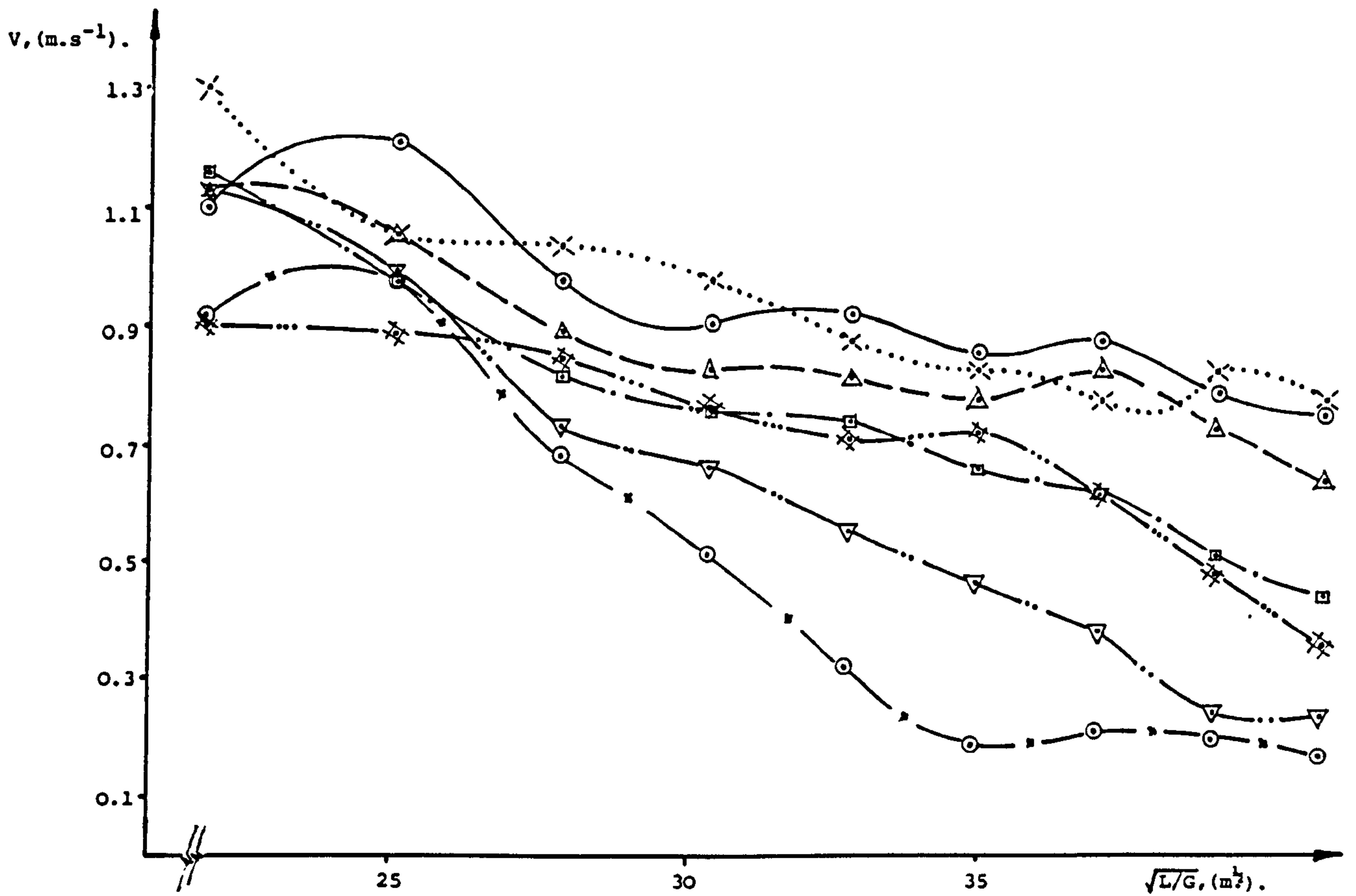

FIGURE 10/62. - INDIVIDUAL SOLID VELOCITY PROFILES OF A RANGE OF TOILET/TISSUE-PAPER SOLIDS, EACH OF WHICH OCCURRED AS THE SOLE CONTENT OF ITS OWN FLUSH, AS RECORDED AS THE FEMALE FACILITY AT GRADIENT 1:150, (W.C.3).

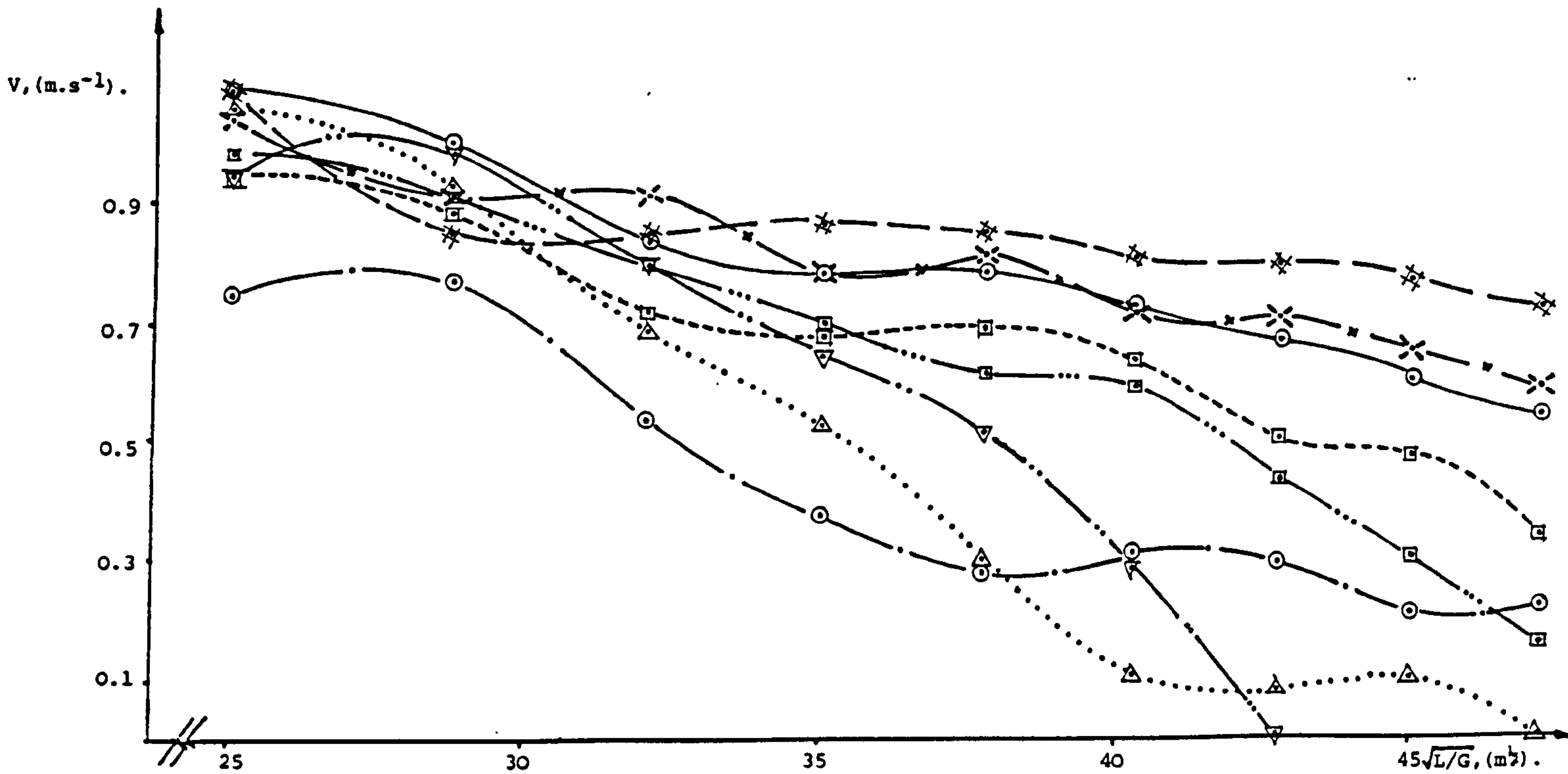

FIGURE 10/63. - INDIVIDUAL SOLID VELOCITY PROFILES OF A RANGE OF TOILET/TISSUE-PAPER SOLIDS, EACH OF WHICH OCCURRED AS THE SOLE CONTENT OF ITS OWN FLUSH, AS RECORDED AT THE FEMALE FACILITY AT GRADIENT 1:200, (W.C.3).

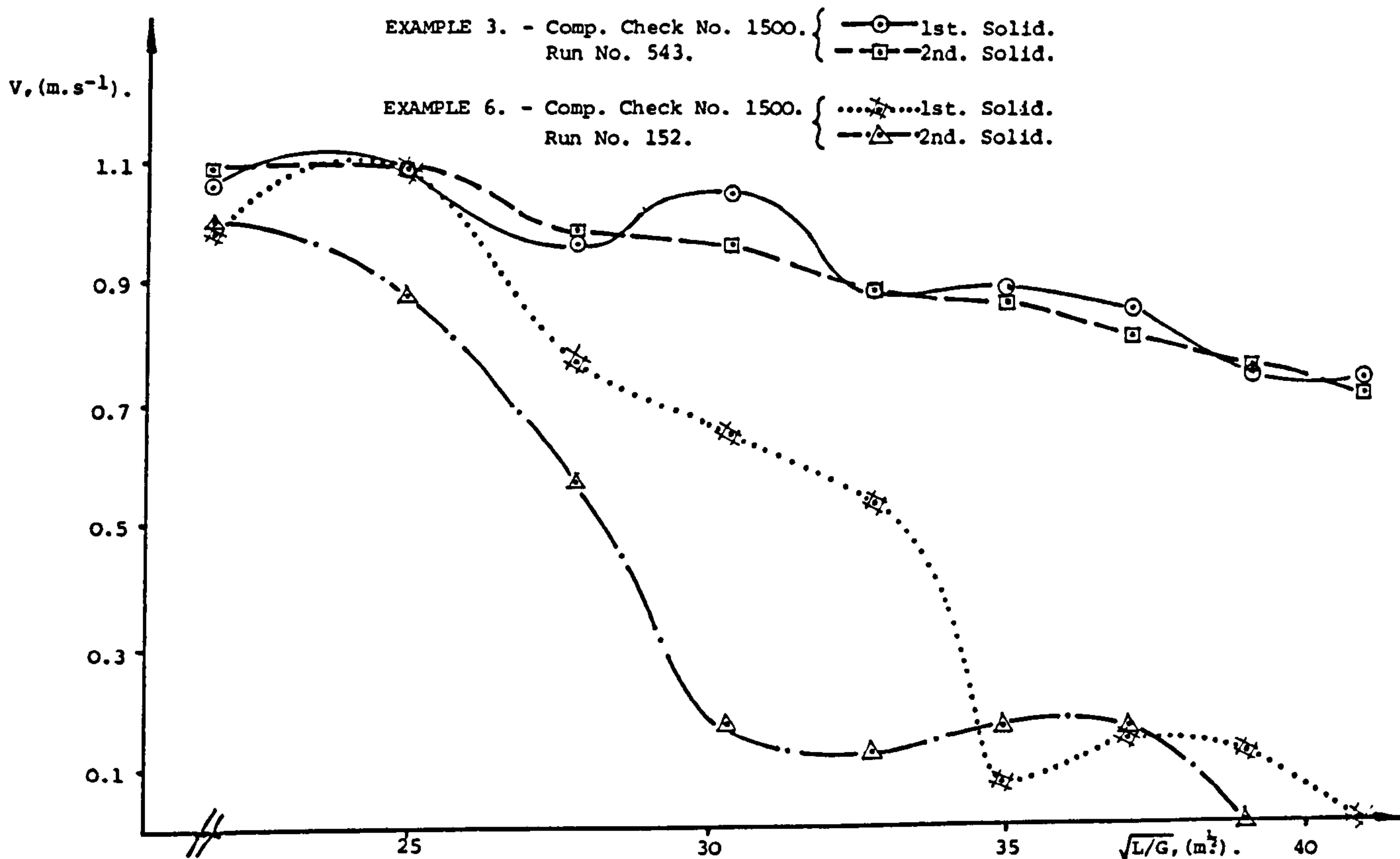

FIGURE 10/66. - INDIVIDUAL SOLID VELOCITY PROFILES OF THE CONTENTS OF SELECTED FLUSHES, EACH OF WHICH CONTAINED TWO OFF TOILET/TISSUE-PAPER SOLIDS. AS RECORDED AT THE FEMALE FACILITY AT GRADIENT 1:150, (W.C.3).

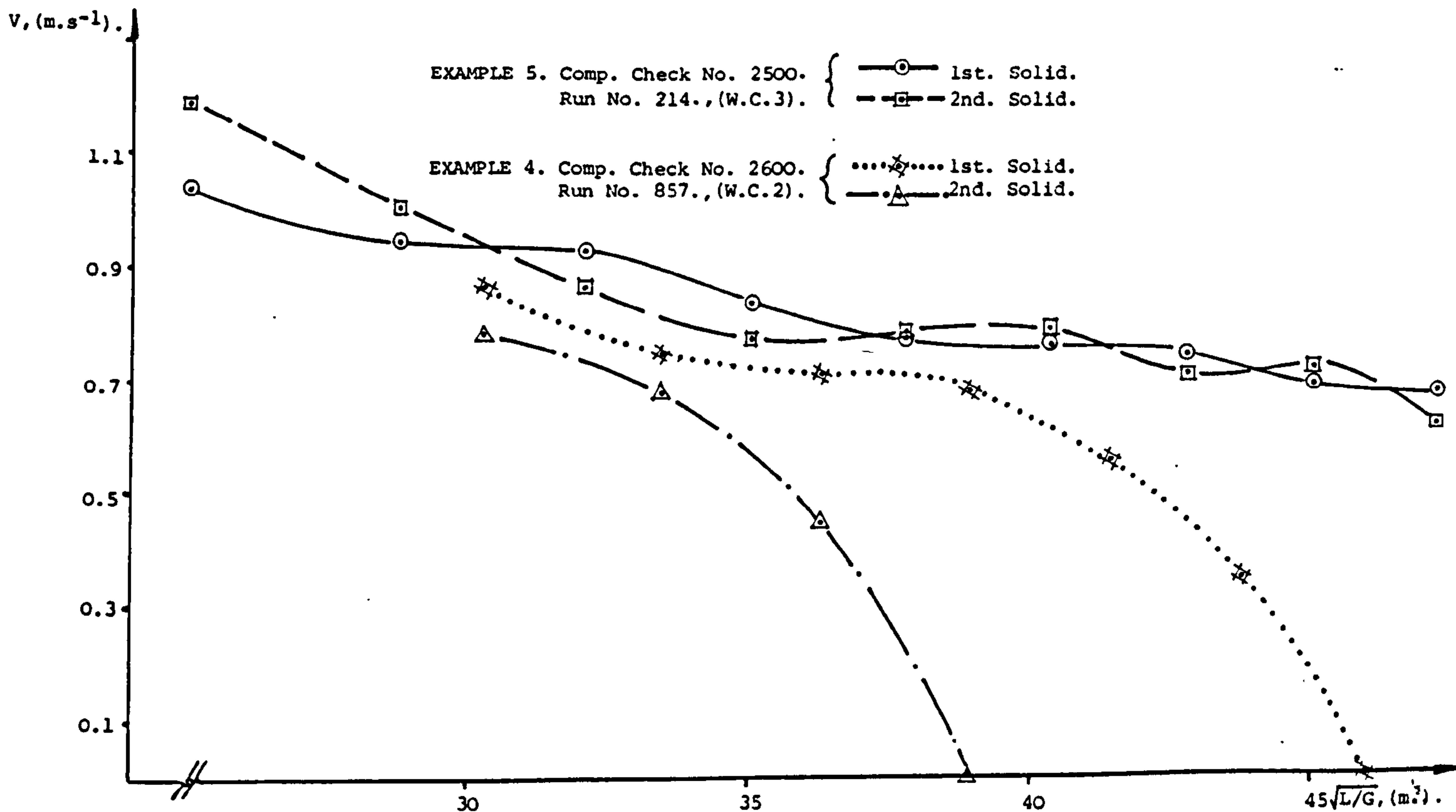

FIGURE 10/67. - INDIVIDUAL SOLID VELOCITY PROFILES OF THE CONTENTS OF SELECTED FLUSHES, EACH OF WHICH CONTAINED TWO OFF TOILET/TISSUE-PAPER SOLIDS, AS RECORDED AT THE FEMALE FACILITY AT GRADIENT 1:200, (W.C.2 and W.C.3).

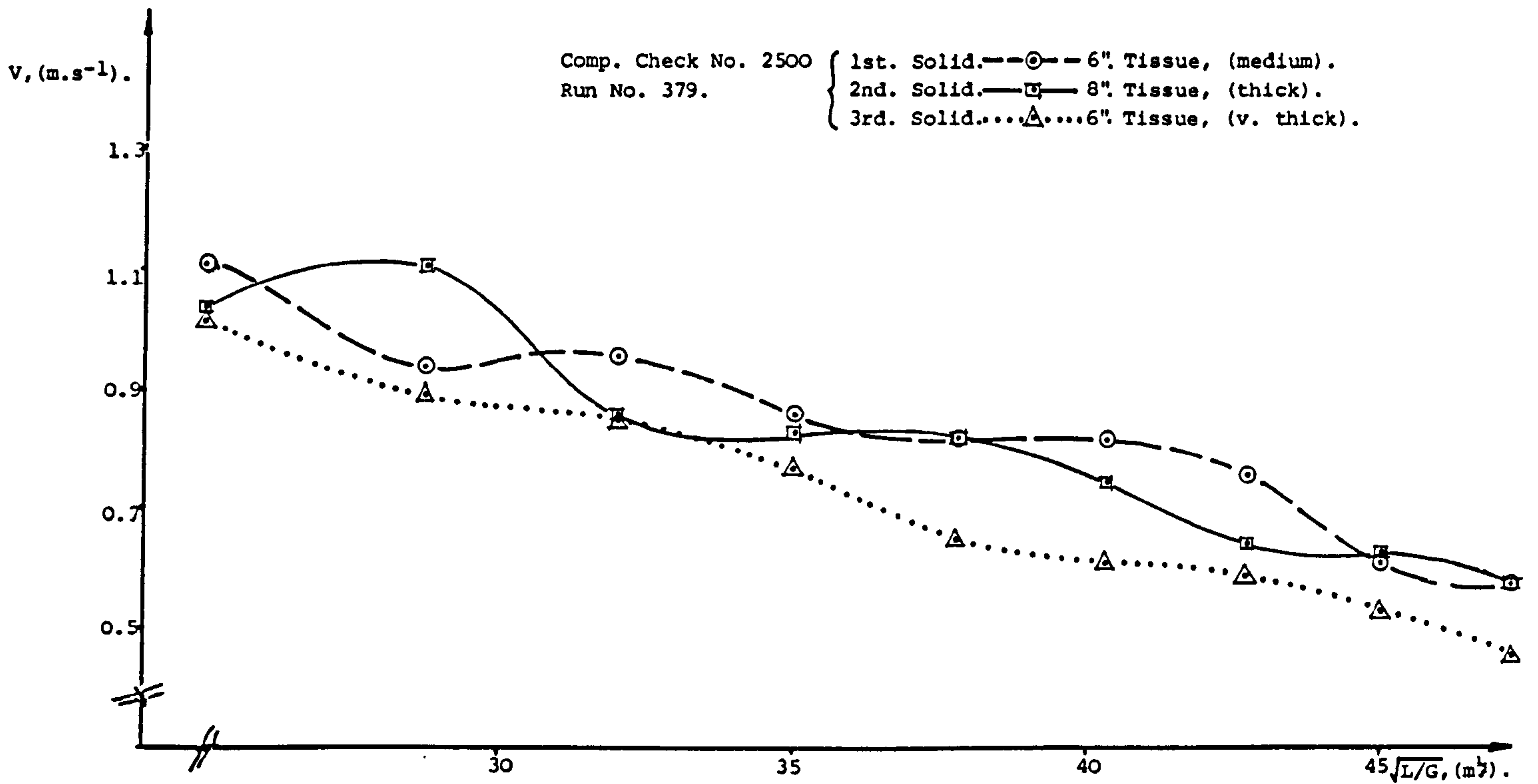

FIGURE 10/68. - INDIVIDUAL SOLID VELOCITY PROFILES OF THE CONTENTS OF A THREE SOLID FLUSH, EACH SOLID BEING OF TOILET/TISSUE-PAPER, AS RECORDED AT THE FEMALE FACILITY AT GRADIENT 1:200, (W.C.3).

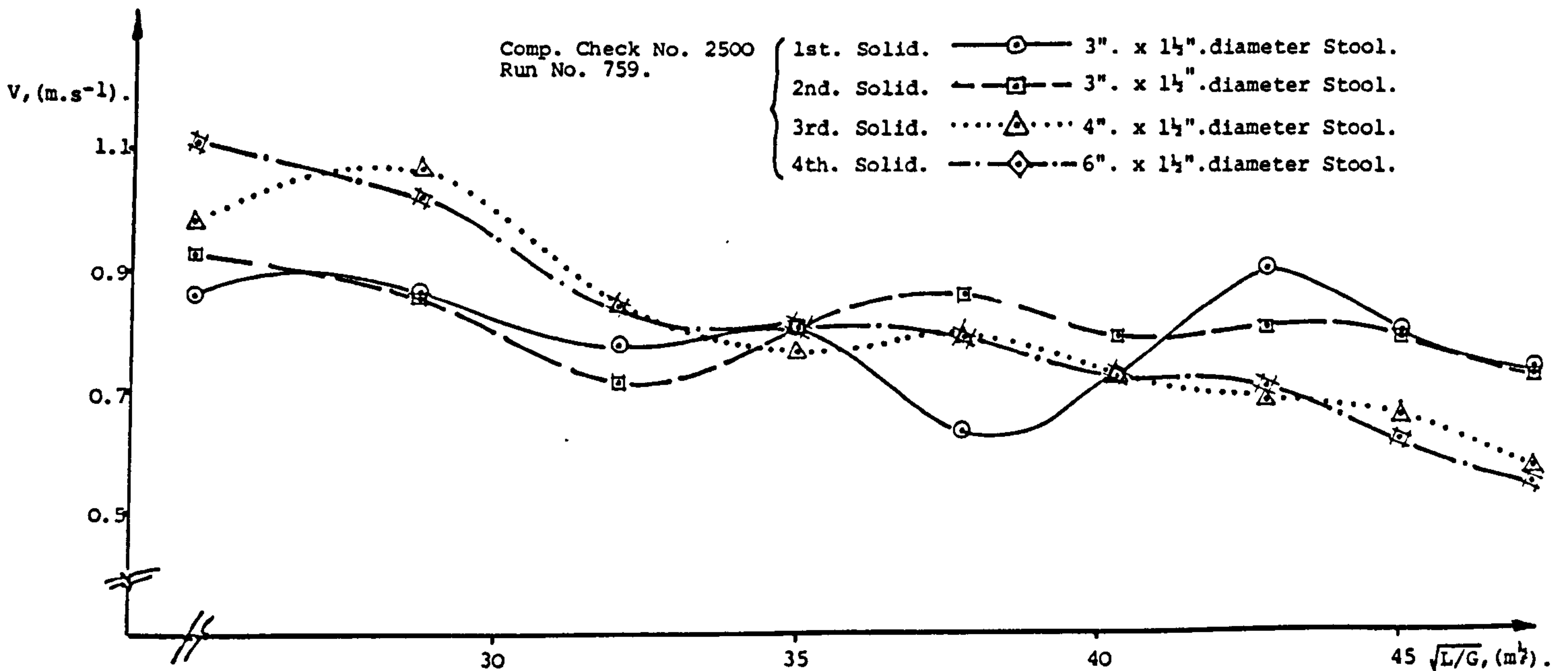

FIGURE 10/69. - INDIVIDUAL SOLID VELOCITY PROFILES OF THE CONTENTS OF A FOUR SOLID FLUSH, EACH SOLID BEING OF FAECAL MATERIAL, AS RECORDED AT THE FEMALE FACILITY AT GRADIENT 1:200, (W.C.3).

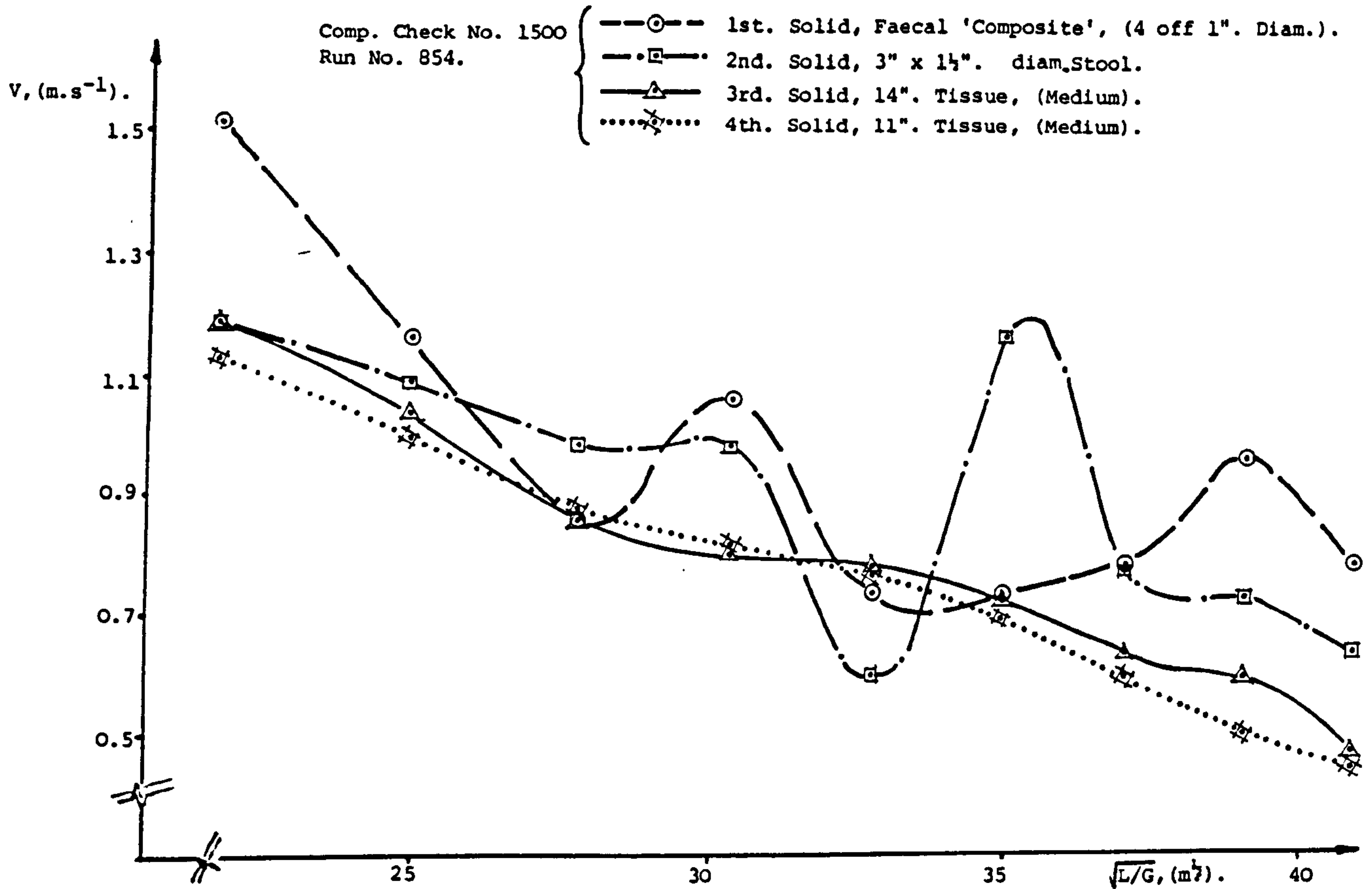

FIGURE 10/70. - INDIVIDUAL SOLID VELOCITY PROFILES, OF THE CONTENTS OF A MIXED 'FAECAL' FLUSH (4 SOLIDS), AS RECORDED AT THE FEMALE FACILITY AT GRADIENT 1:150, (W.C.3).

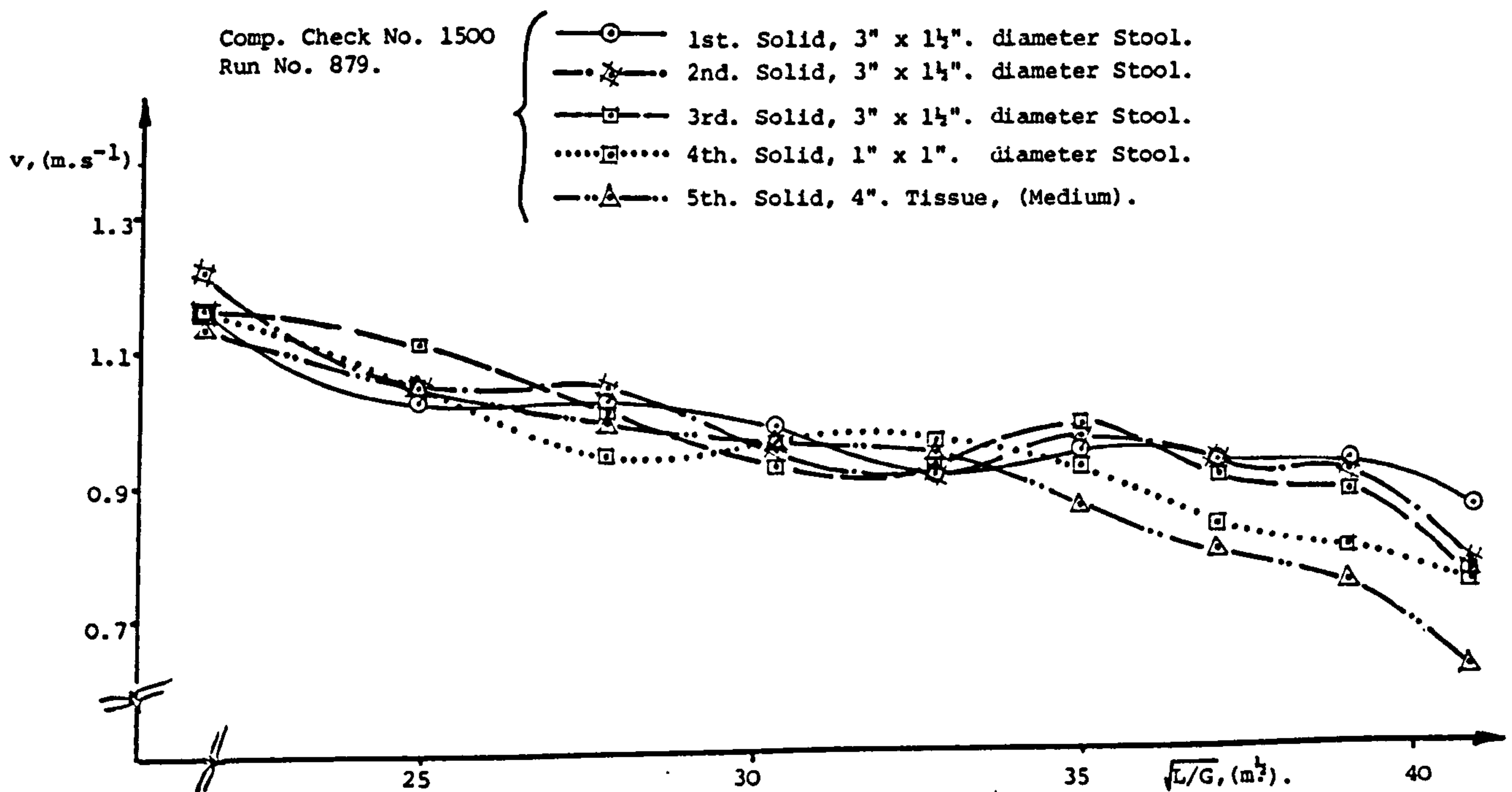

FIGURE 10/71. - INDIVIDUAL SOLID VELOCITY PROFILES OF THE CONTENTS OF A MIXED 'FAECAL' FLUSH (5 SOLIDS), AS RECORDED AT THE FEMALE FACILITY AT GRADIENT 1:150, (W.C.3).

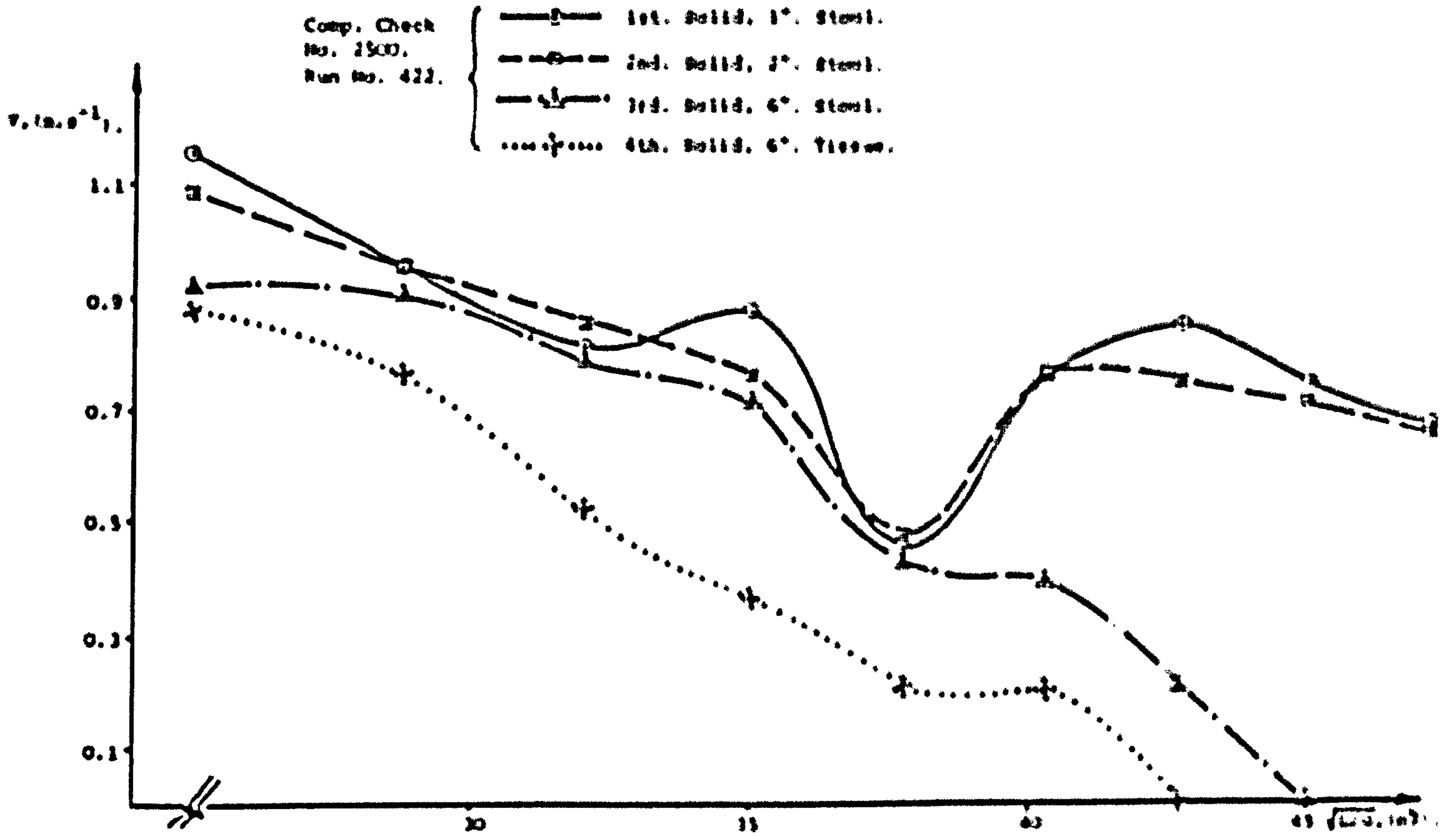

FIGURE 10/72. - INDIVIDUAL SOLID VELOCITY PROFILES OF THE CONTENTS OF A MIXED 'FAECAL' FLUSH (4 SOLIDS), AS RECORDED AT THE FEMALE FACILITY AT GRADIENT 1.200, (M.C. 3).

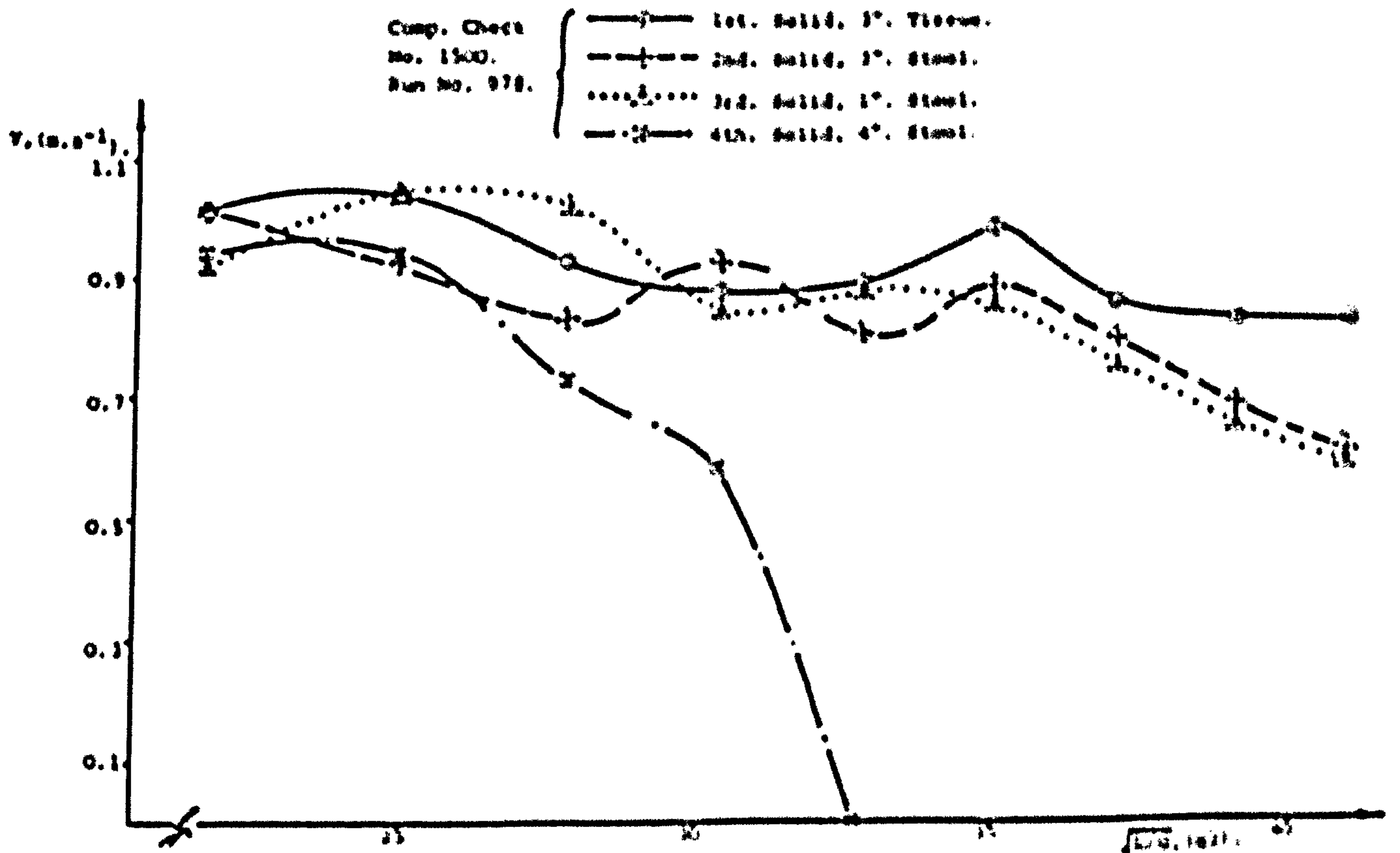

FIGURE 10/73. - INDIVIDUAL SOLID VELOCITY PROFILES OF THE CONTENTS OF A MIXED 'FAECAL' FLUSH (4 SOLIDS), AS RECORDED AT THE FEMALE FACILITY AT GRADIENT 1.150, (M.C. 3).

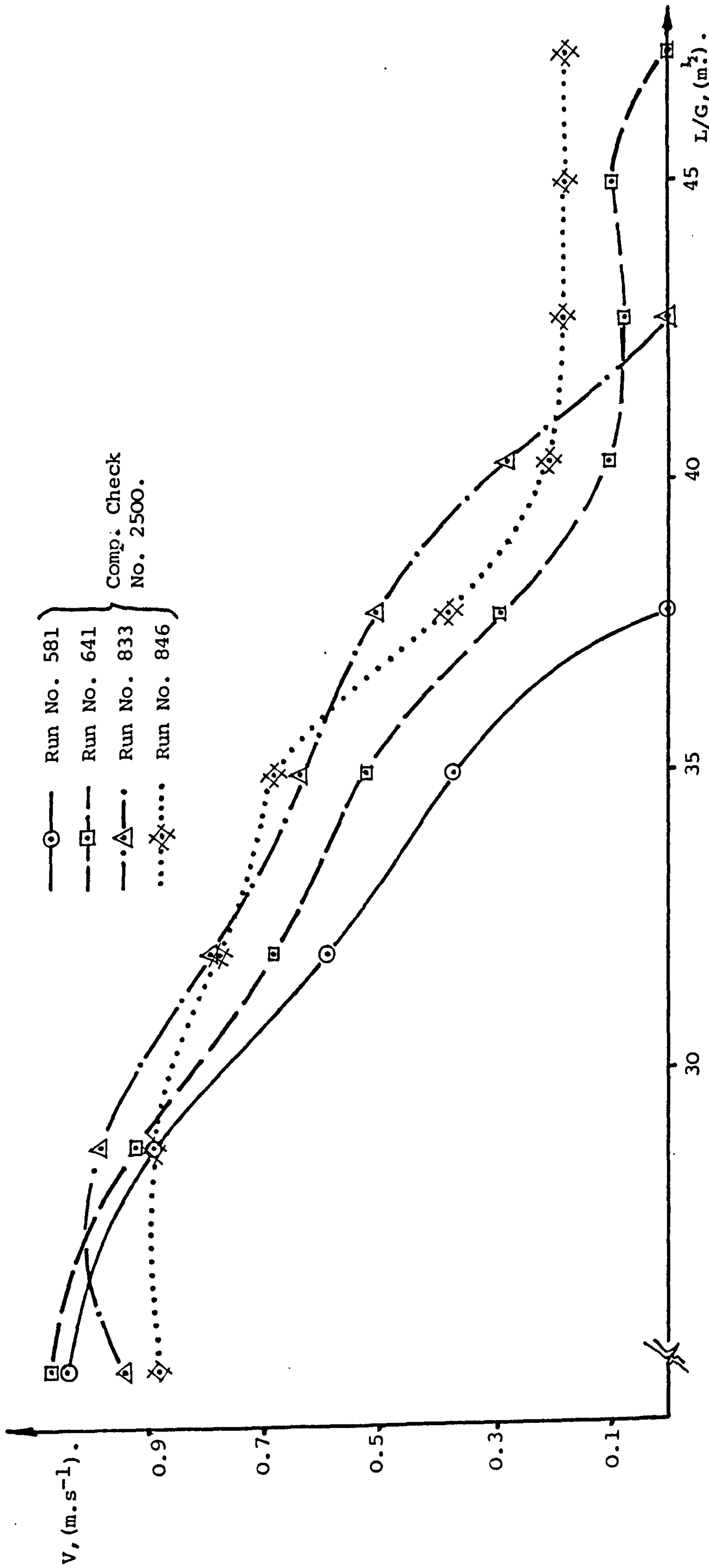

FIGURE 10/74. - INDIVIDUAL SOLID VELOCITY PROFILES OF A SELECTION OF TOILET/TISSUE-PAPER SOLIDS, EACH OF WHICH OCCURRED AS THE SOLE CONTENT OF ITS OWN FLUSH, AS RECORDED AT THE FEMALE FACILITY AT GRADIENT 1.200, (W.C.3).

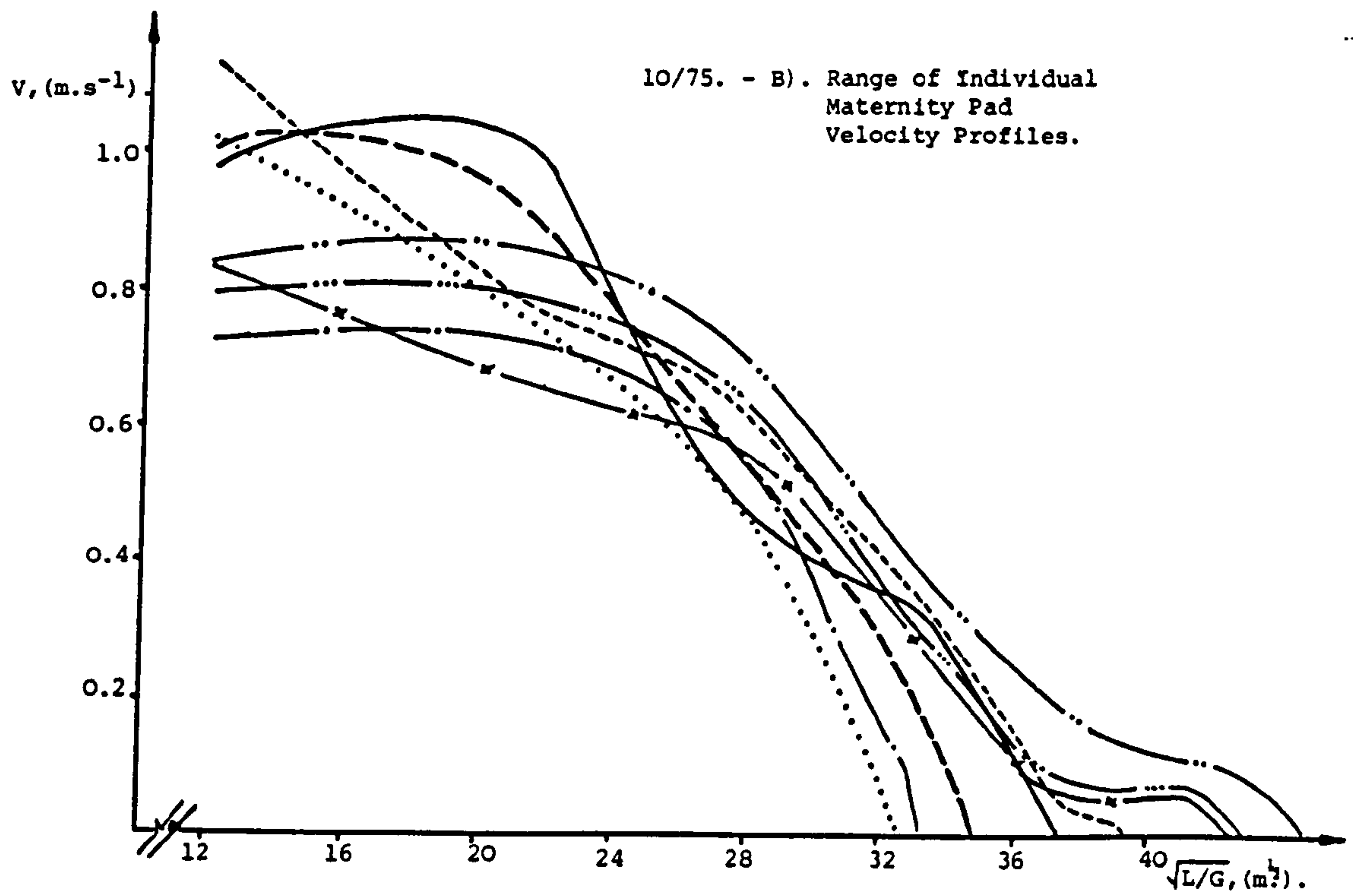
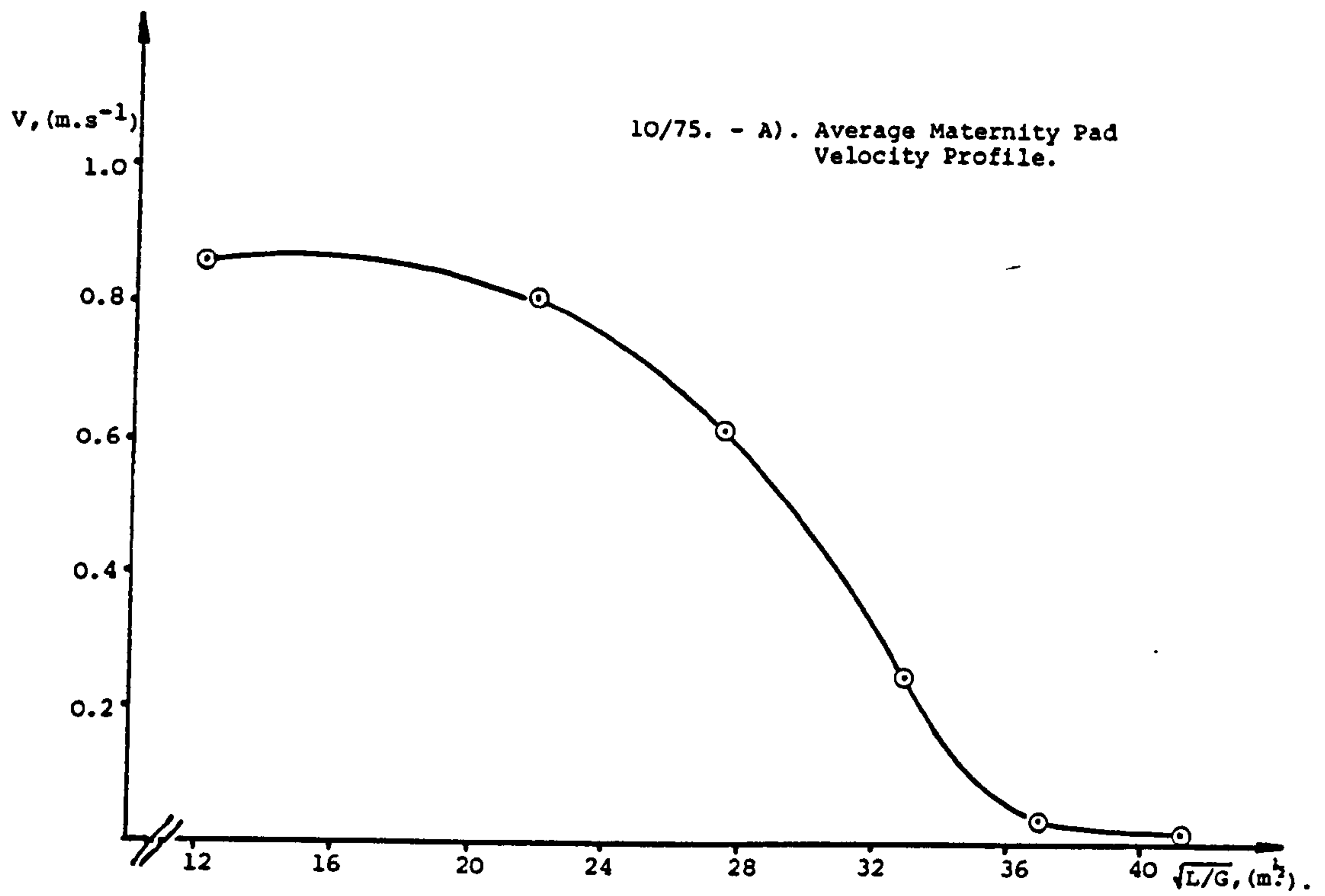

FIGURE 10/75. - RE-EXAMINATION OF MATERNITY PAD PERFORMANCE FOR 'ZONE 3' FLOW CONDITIONS, - based on Wakelin's (1978) results, as recorded, at gradient 1:150, using an Armitage Shanks 'p-trap' un-vented W.C. pan.

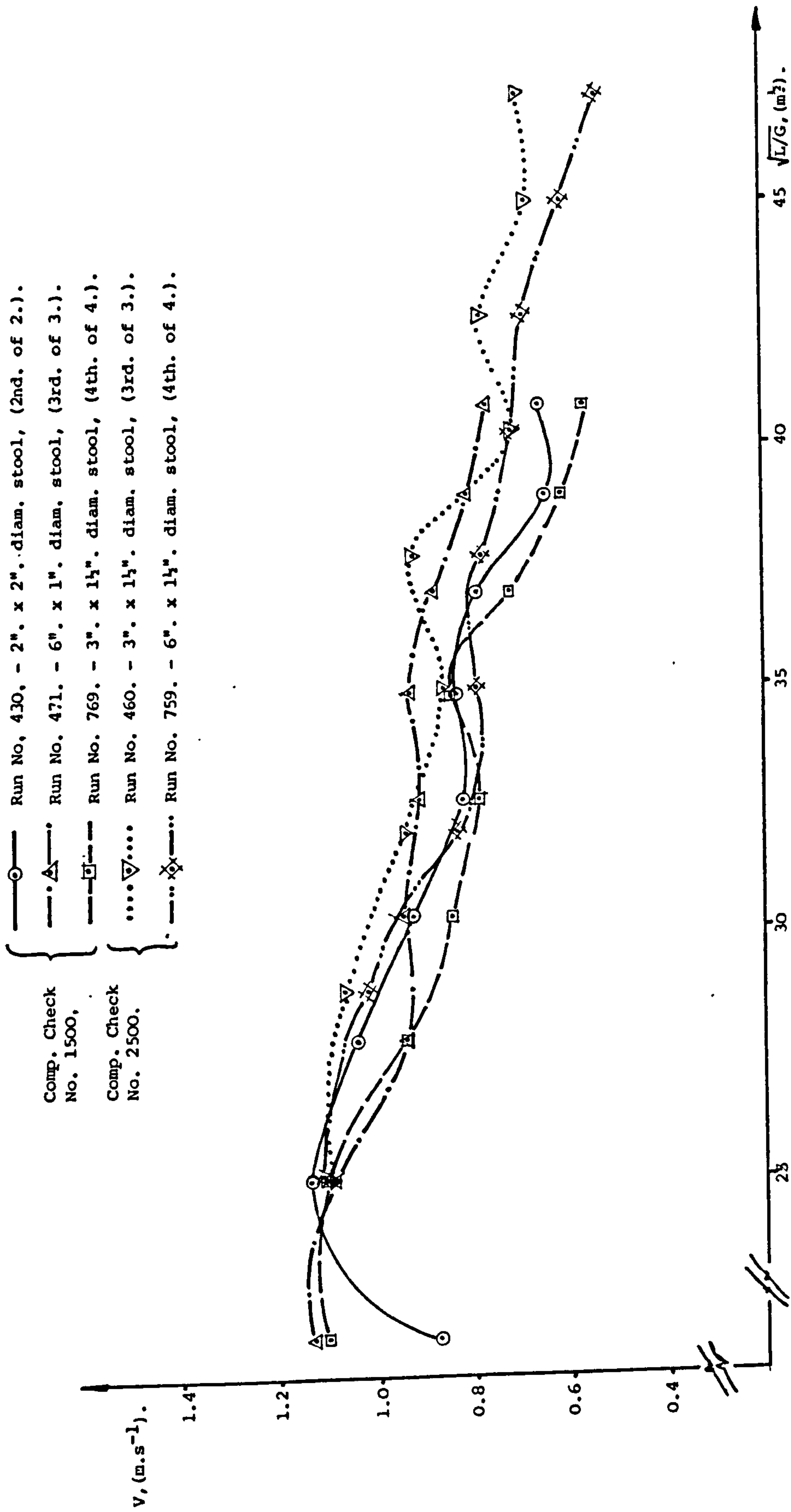

FIGURE 10/76. - INDIVIDUAL SOLID VELOCITY PROFILES OF A RANGE OF FAECAL SOLIDS, EACH OF WHICH OCCURRED AS THE 'TRAILING SOLID' OF A MIXED CONTENT 'FAECAL' FLUSH, AS RECORDED AT THE FEMALE FACILITY AT GRADIENTS 1:150 AND 1:200, (W.C.3).

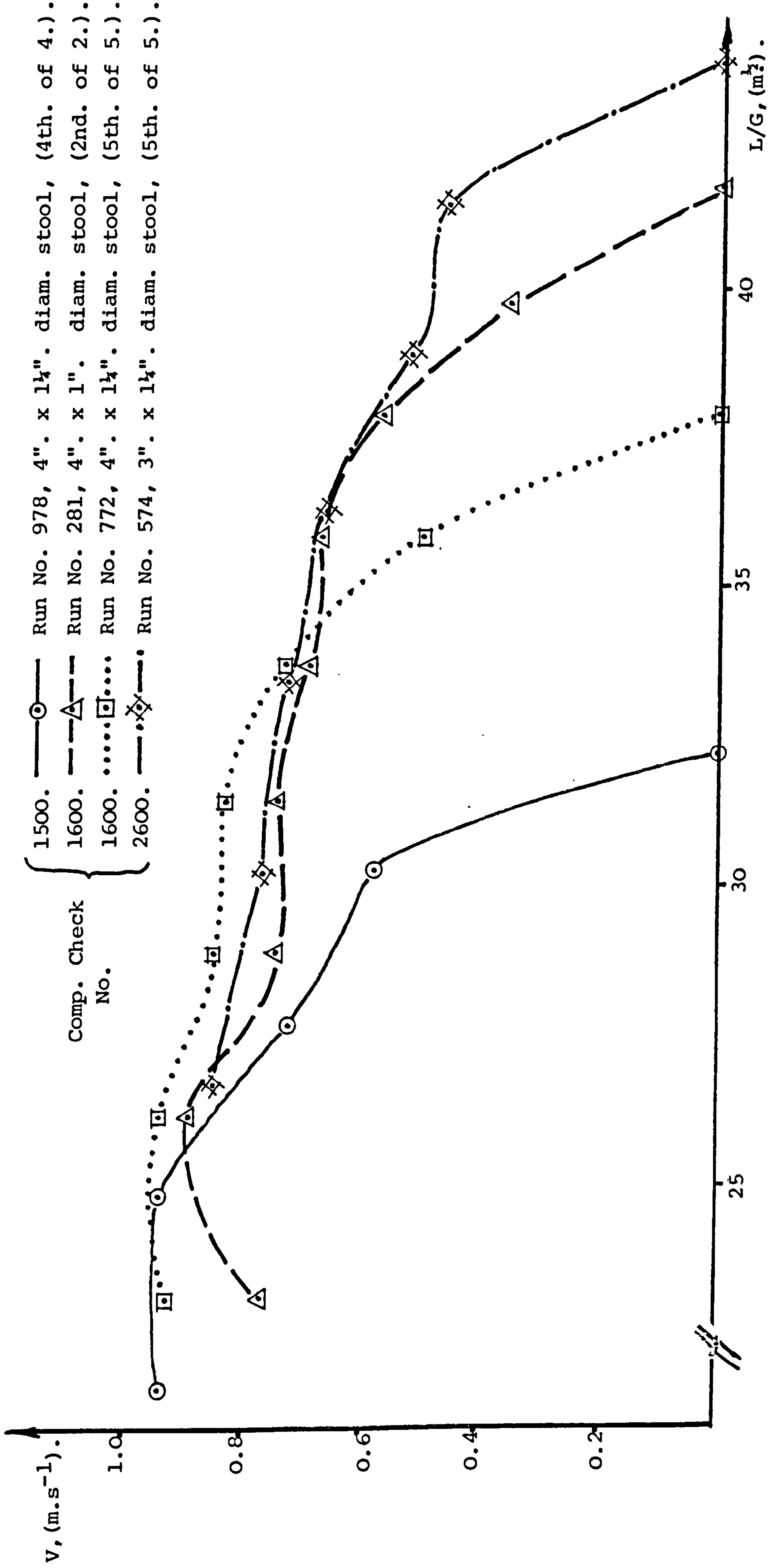

FIGURE 10/77. - INDIVIDUAL SOLID VELOCITY PROFILES OF A SELECTION OF FAECAL SOLIDS, EACH OF WHICH OCCURRED AS THE 'TRAILING SOLID' OF A MIXED CONTENT 'FAECAL' FLUSH, AS RECORDED AT THE FEMALE FACILITY AT GRADIENTS 1:150 AND 1:200, (W.C.2 AND W.C.3).

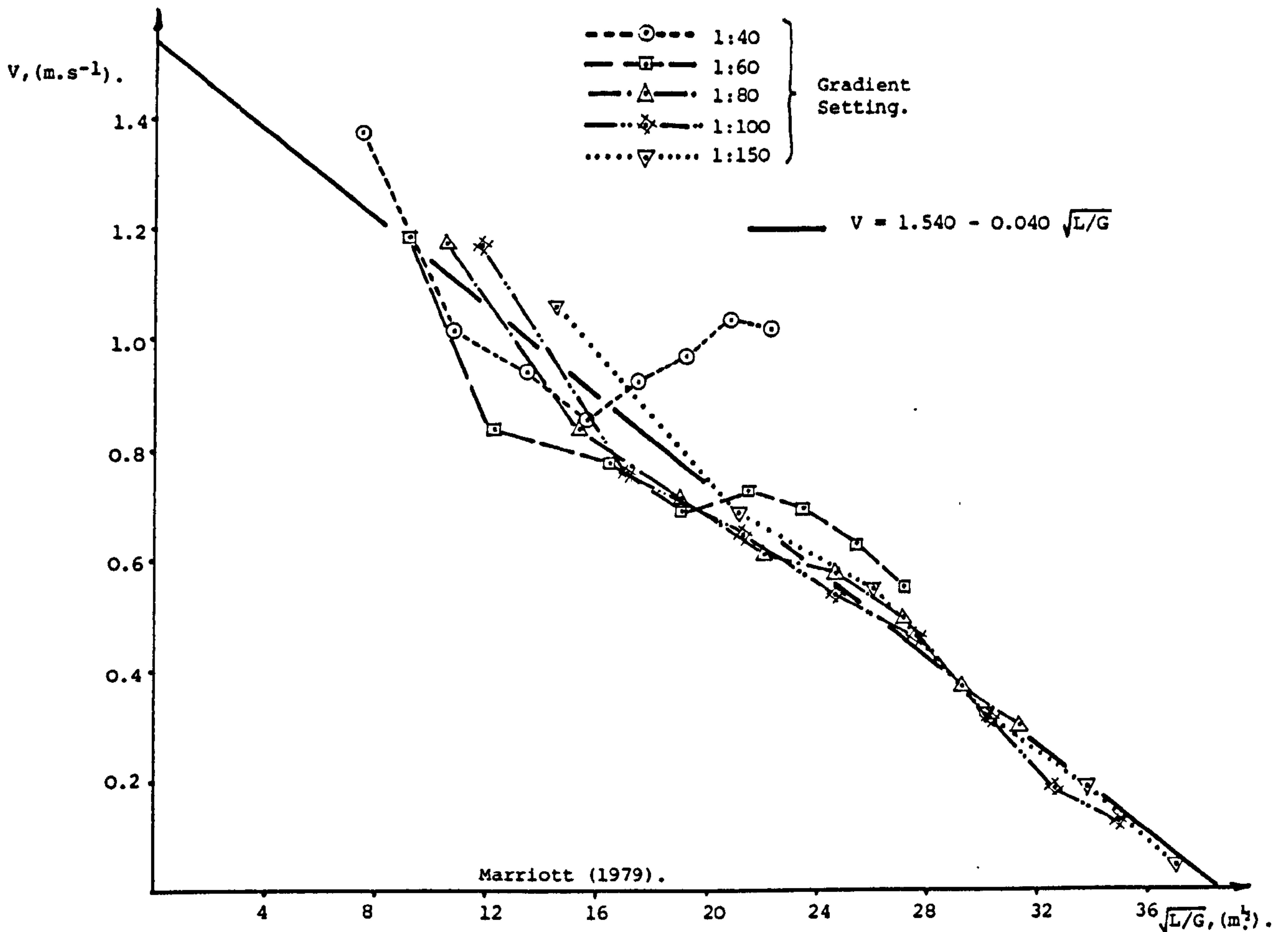

FIGURE 10/78. - AVERAGE 'MATERNITY PAD' VELOCITY PROFILES, AS RECORDED, OVER A RANGE OF DIFFERENT GRADIENTS, USING A VENTED TWYFORDS B.S. 1213 'P-TRAP' W.C. PAN.

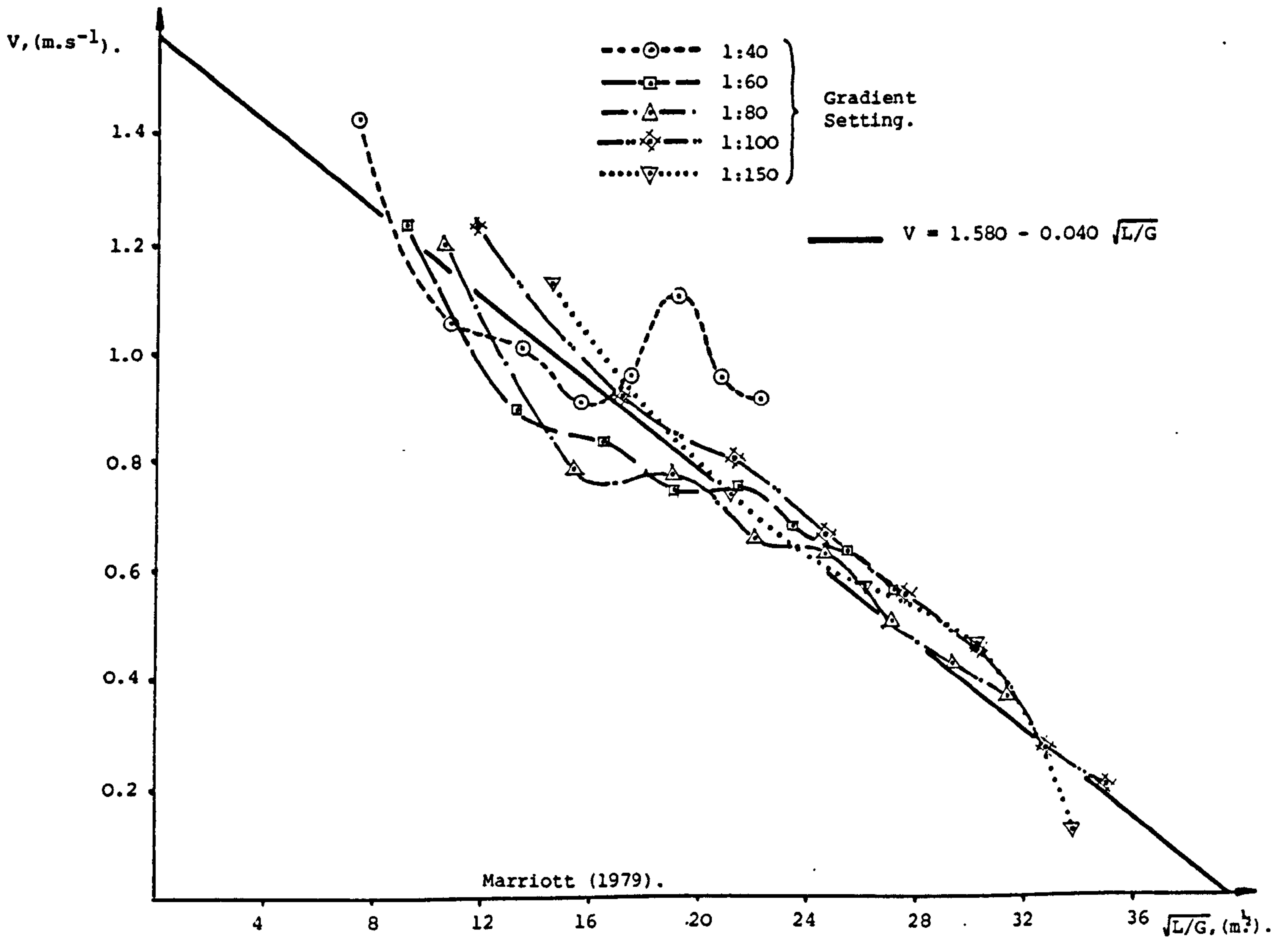

FIGURE 10/79. - AVERAGE 'MATERNITY PAD' VELOCITY PROFILES, AS RECORDED, OVER A RANGE OF DIFFERENT GRADIENTS, USING A VENTED TWYFORDS EUROPEAN 'P-TRAP' W.C. PAN.

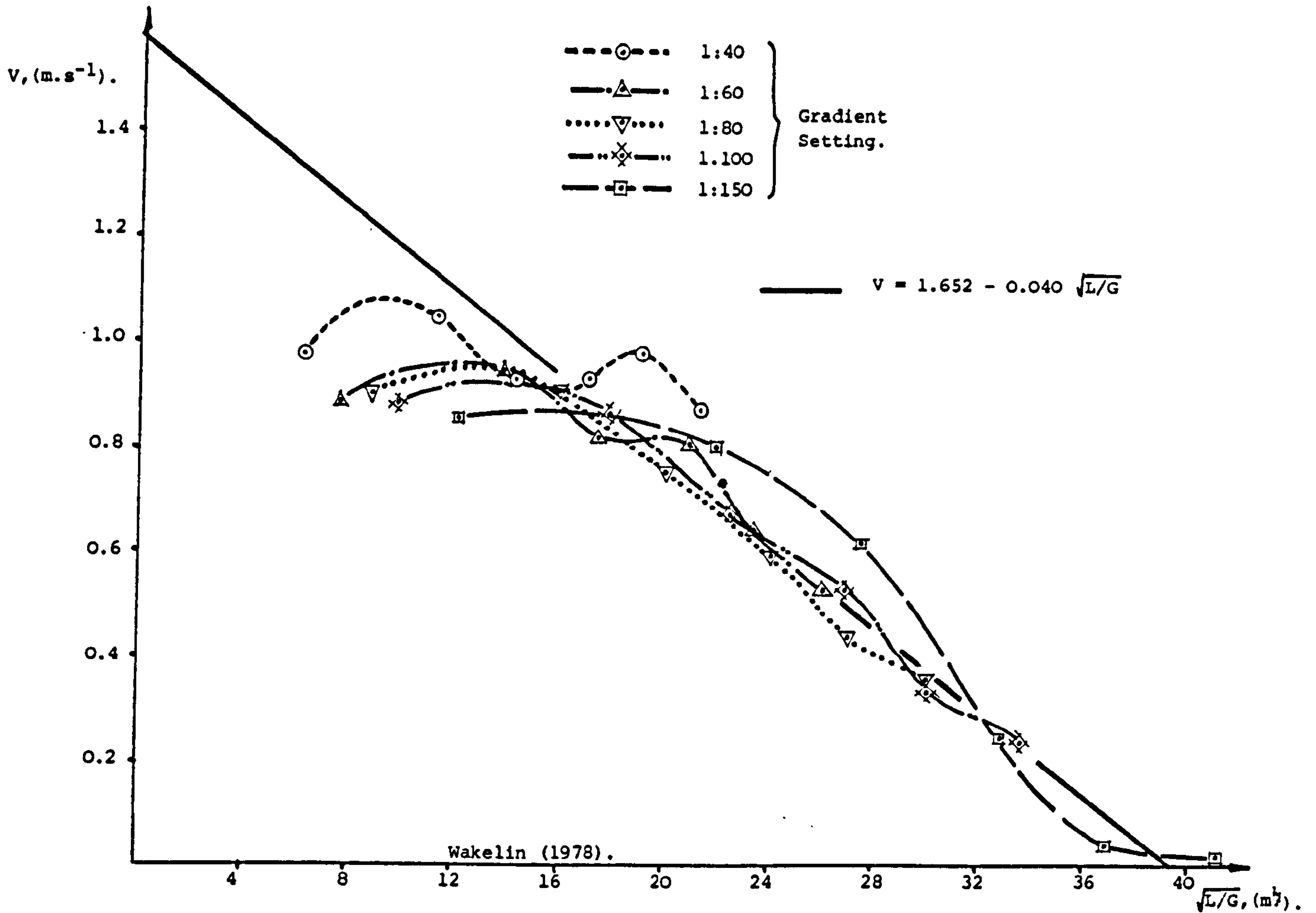

FIGURE 10/80. - AVERAGE 'MATERNITY PAD' VELOCITY PROFILES, AS RECORDED, OVER A RANGE OF DIFFERENT GRADIENTS, USING AN UN-VENTED ARMITAGE SHANKS 'P-TRAP' W.C. PAN.

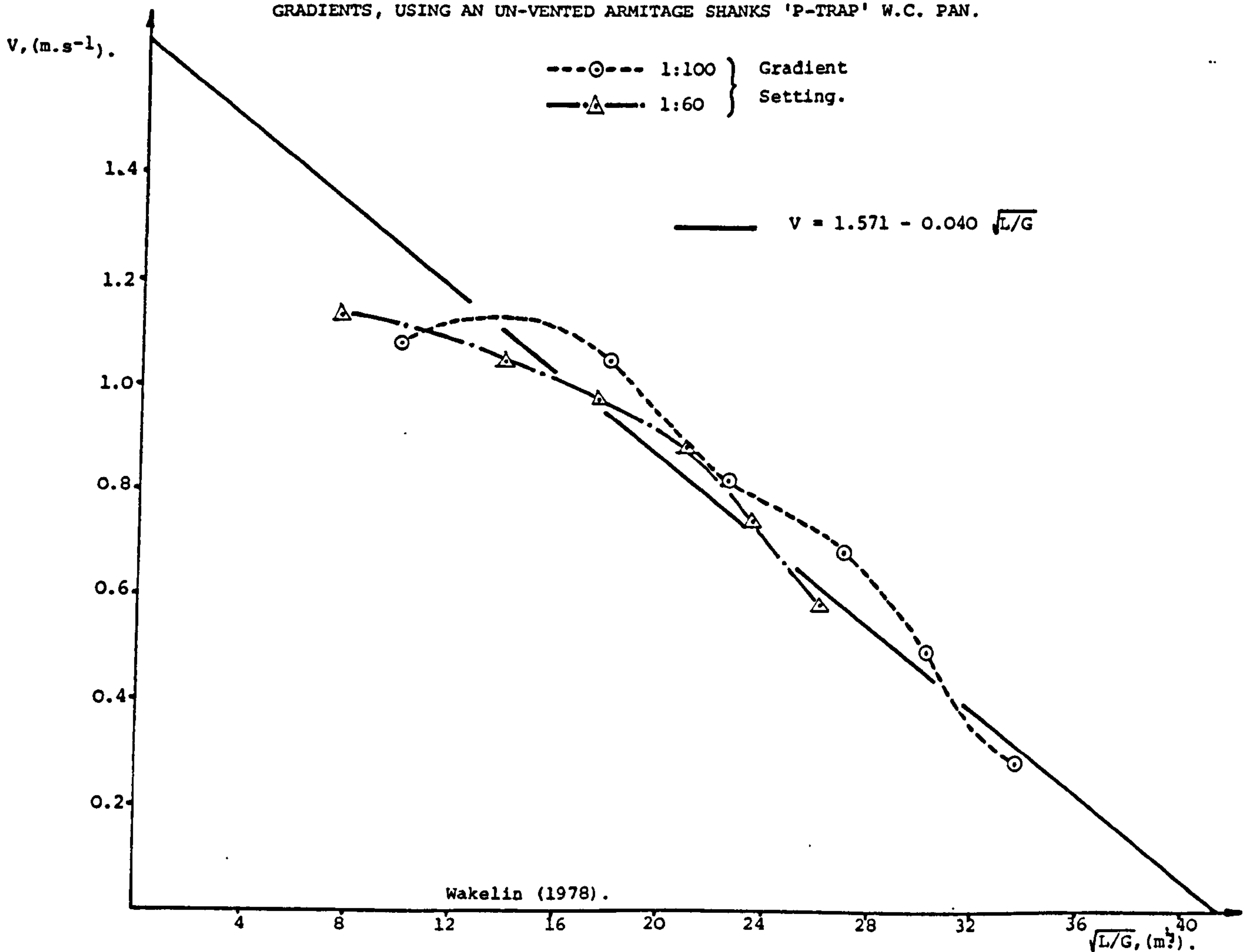

FIGURE 10/81. - AVERAGE 'MATERNITY PAD' VELOCITY PROFILES, AS RECORDED, AT GRADIENTS 1:60 AND 1:100, USING AN UN-VENTED ARMITAGE SHANKS 'S-TRAP' W.C. PAN.

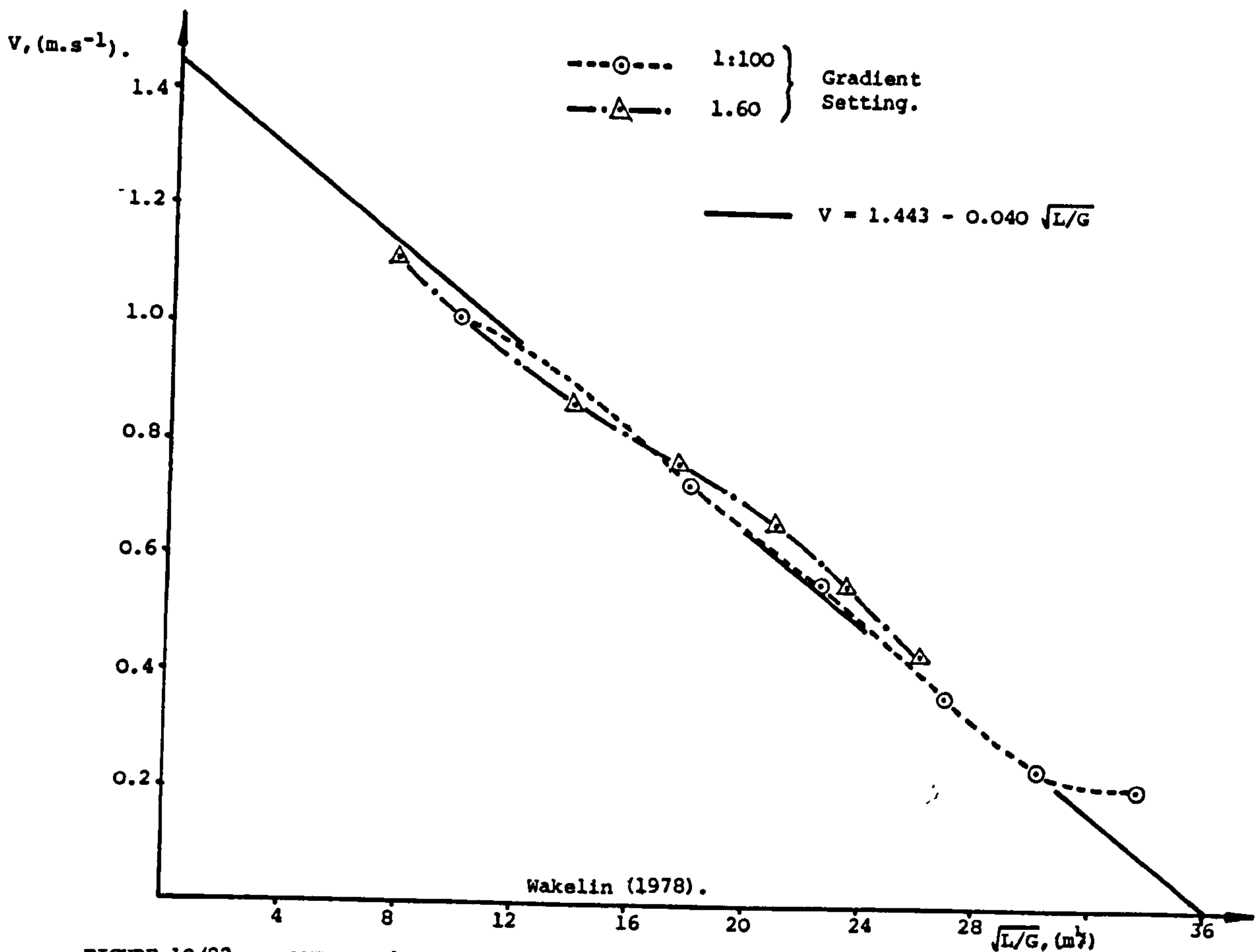

FIGURE 10/82. - AVERAGE 'MATERNITY PAD' VELOCITY PROFILES, AS RECORDED, AT GRADIENTS 1:60 AND 1:100, USING AN UN-VENTED TWYFORDS 'P-TRAP' W.C. PAN.

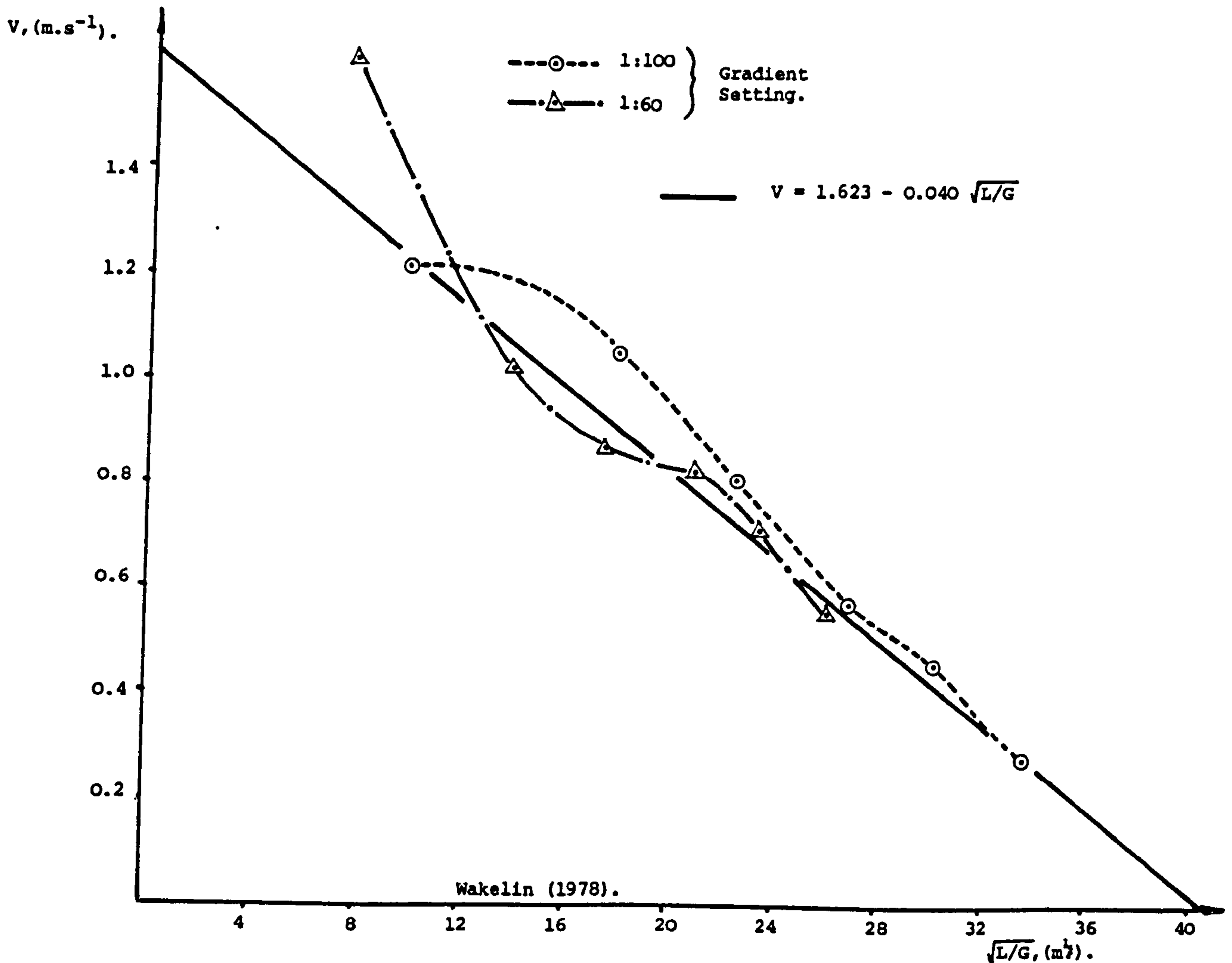

FIGURE 10/83. - AVERAGE 'MATERNITY PAD' VELOCITY PROFILES, AS RECORDED, AT GRADIENTS 1:60 AND 1:100, USING AN UN-VENTED TWYFORDS 'S-TRAP' W.C. PAN.

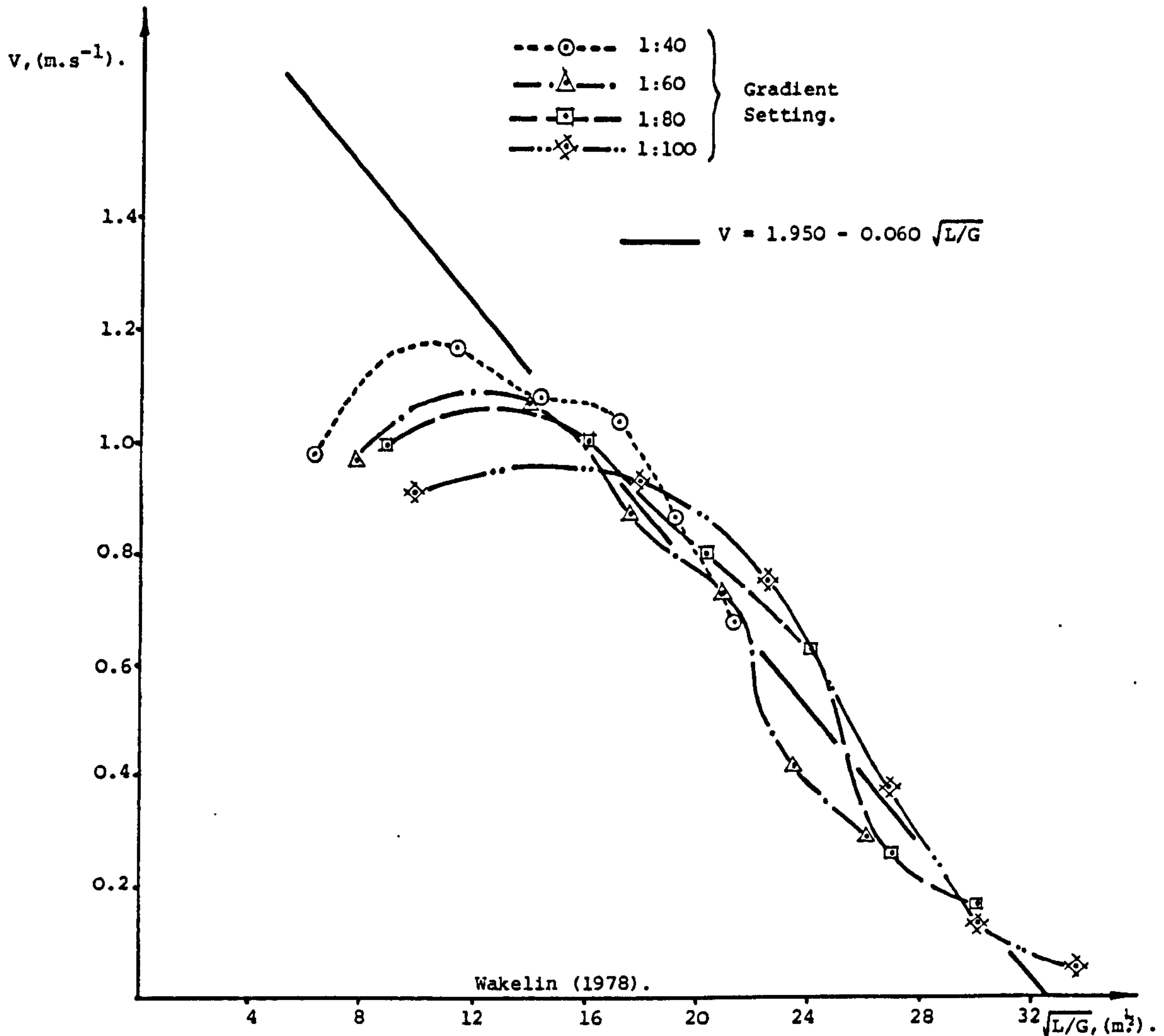

FIGURE 10/84. - AVERAGE VELOCITY PROFILES OF THE 'MATERNITY PAD & 3. KLEENEX TOWEL' WASTE LOAD, AS RECORDED, OVER A RANGE OF DIFFERENT GRADIENTS, USING AN UN-VENTED ARMITAGE SHANKS 'P-TRAP' W.C. PAN.

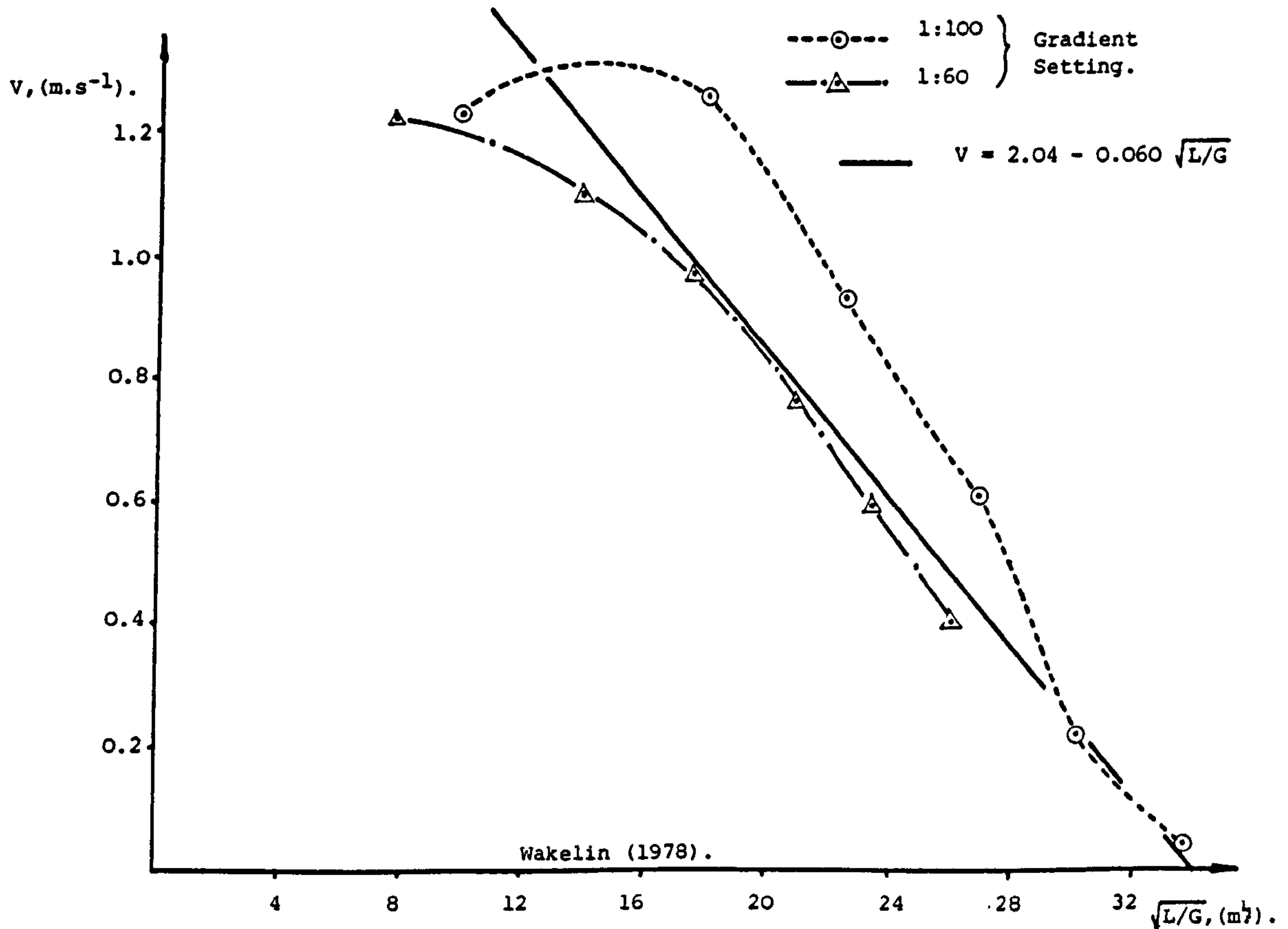

FIGURE 10/85. - AVERAGE VELOCITY PROFILES OF THE 'MATERNITY PAD & 3. KLEENEX TOWEL' WASTE LOAD, AS RECORDED, AT GRADIENTS 1:60 AND 1:100, USING AN UN-VENTED ARMITAGE SHANKS 'S-TRAP' W.C. PAN.

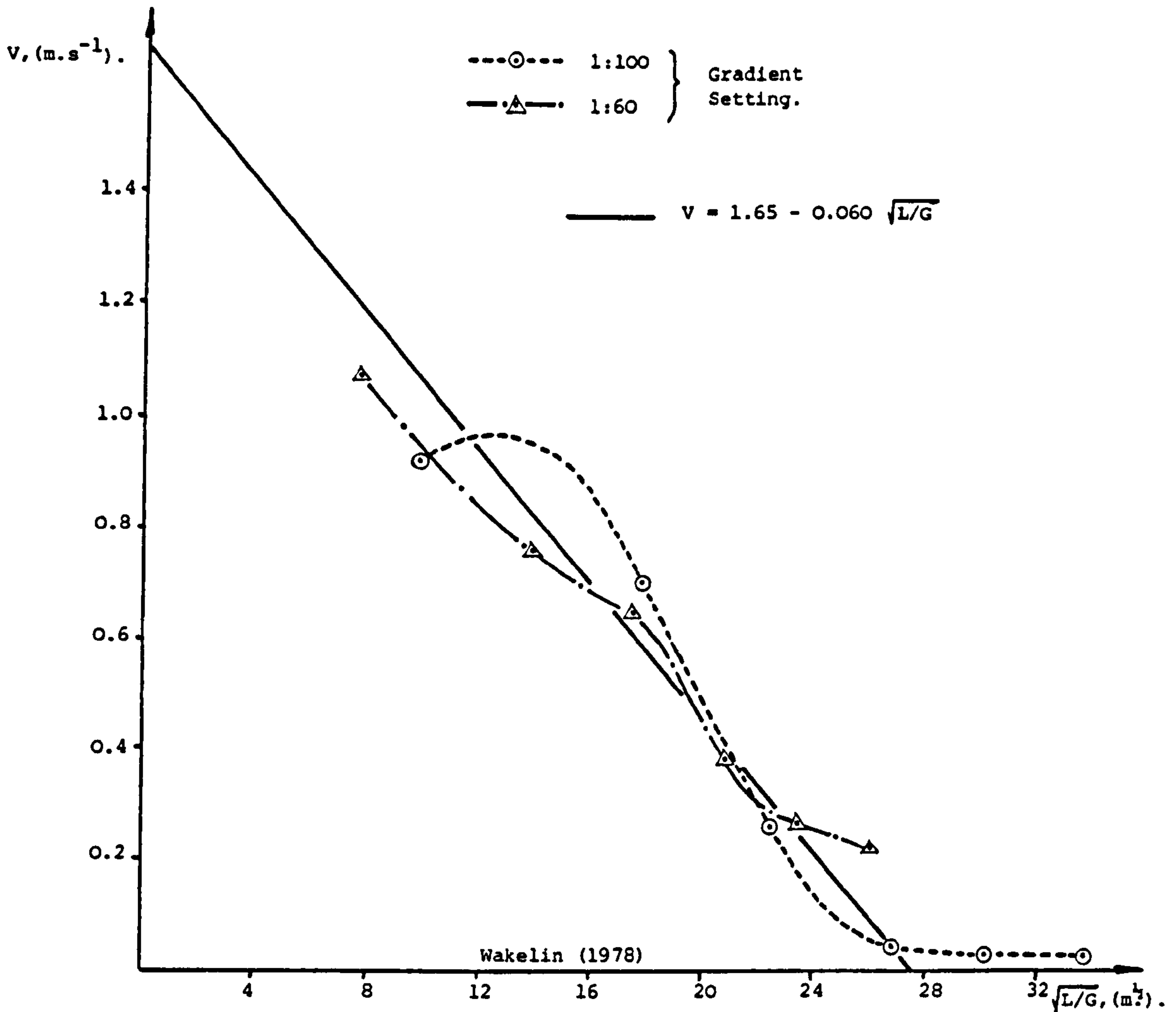

FIGURE 10/86. - AVERAGE VELOCITY PROFILES OF THE 'MATERNITY PAD & 3 KLEENEX TOWEL' WASTE LOAD, AS RECORDED AT GRADIENTS 1:60 AND 1:100, USING AN UN-VENTED TWYFORDS 'P-TRAP' W.C. PAN.

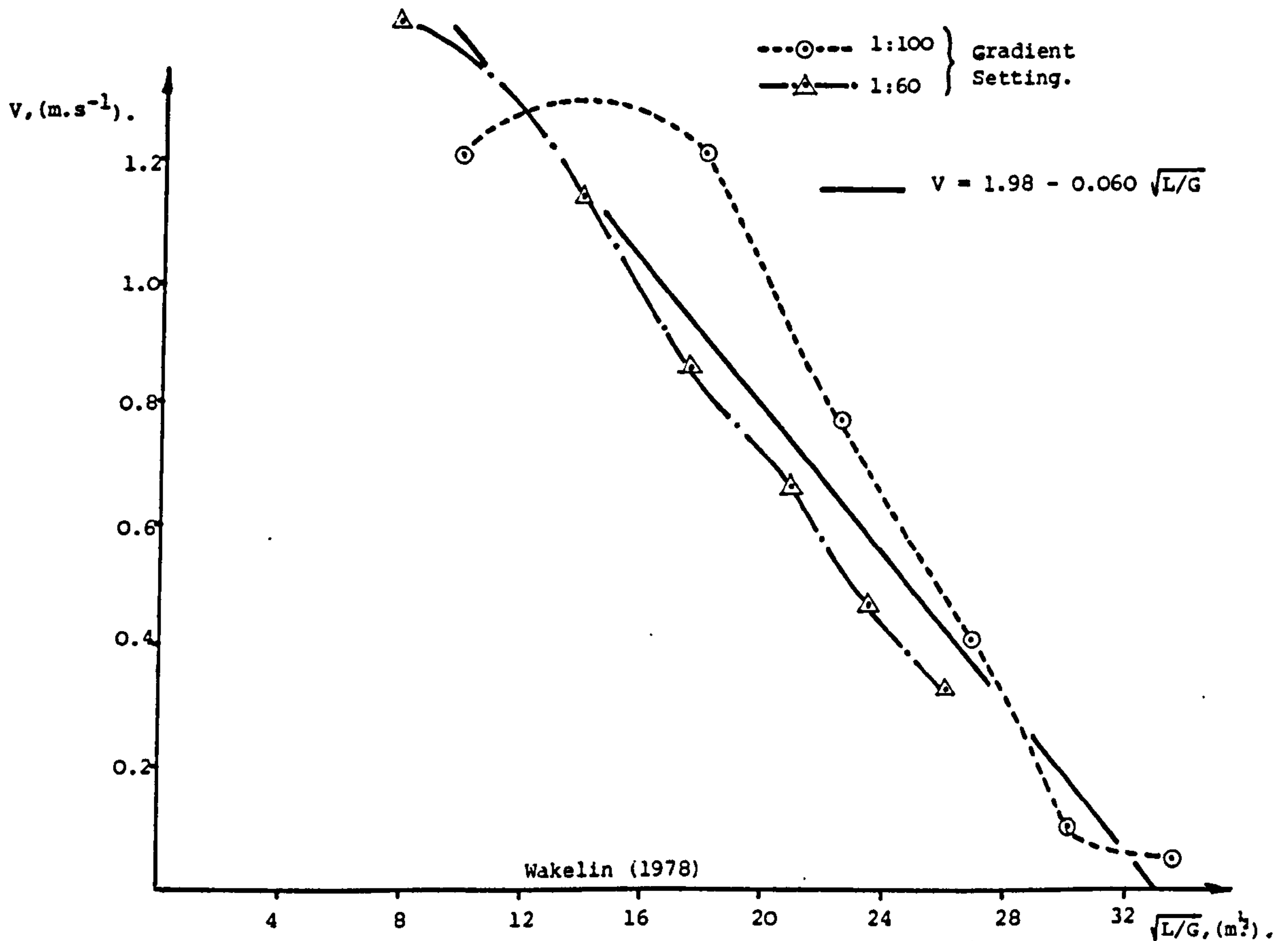

FIGURE 10/87. - AVERAGE VELOCITY PROFILES OF THE 'MATERNITY PAD & 3 KLEENEX TOWEL' WASTE LOAD, AS RECORDED, AT GRADIENTS 1:60 AND 1:100, USING AN UN-VENTED TWYFORDS 'S-TRAP' W.C. PAN.

INPUT DEVICE.	Fig. No. of GRAPH, PRES.	SOLID TYPE.	W.C. CONDITION.	REPORTED VELOCITY CONSTANTS.			RE-ASSESSED VELOCITY CONSTANTS.		
				C1.	C2.	C3.	C1.	C2.	C3.
ARMITAGE SHANKS V1206 'Back Inlet' P-Trap W.C. Pan.	(10/80). * (10/95).	↑	UN-VENTED VENTED	1.798 1.644	0.0476 0.0438	37.8 37.5	1.571 1.520	0.040 0.040	39.3 38.0
ARMITAGE SHANKS V1206 'Back Inlet' S-Trap W.C. Pan.	(10/61). * (10/96)	↑	UN-VENTED VENTED	1.8415 1.8437	0.0459 0.0455	40.1 40.5	1.652 1.650	0.040 0.040	41.3 41.2
TWYFORDS 11006 'Back Inlet' P-Trap W.C. Pan.	(10/82). * (10/97).	SINGLE MATERNITY PAD.	UN-VENTED VENTED	1.4935 1.4346	0.0411 0.0380	36.3 37.8	1.443 1.480	0.040 0.040	36.1 37.0
TWYFORDS 11006 'Back Inlet' S-Trap W.C. Pan.	(10/83). * (10/98).	↑	UN-VENTED VENTED	1.8337 1.8200	0.0468 0.0464	39.2 39.2	1.623 1.620	0.040 0.040	40.6 40.5
TWYFORDS B.S.1213 'Back Inlet' P-Trap W.C. Pan.	- ** (10/78).	↑	UN-VENTED VENTED	- 1.507	- 0.0388	- 38.8	- 1.540	- 0.040	- 38.5
TWYFORDS EURO. REG. 'Back Inlet' P-Trap W.C. Pan.	- ** (10/79).	↑	UN-VENTED VENTED	- 1.564	- 0.0390	- 40.1	- 1.580	- 0.040	- 39.5
ARMITAGE SHANKS V1206 'Back Inlet' P-Trap W.C. Pan.	(10/84). * (10/99).	MATERNITY PAD &	UN-VENTED VENTED	2.0154 1.9742	0.0623 0.0642	32.3 30.8	1.950 1.860	0.060 0.060	32.5 31.0
ARMITAGE SHANKS V1206 'Back Inlet' S-Trap W.C. Pan.	(10/85). * (10/100).	3 KLEENEX TOWELS.	UN-VENTED VENTED	2.2484 2.2057	0.0663 0.0639	33.9 34.5	2.040 2.040	0.060 0.060	34.0 34.0
TWYFORDS 11006 'Back Inlet' P-Trap W.C. Pan.	(10/86). * (10/101).	↑	UN-VENTED VENTED	1.4648 1.6764	0.0506 0.0598	28.9 28.0	1.650 1.710	0.060 0.060	27.5 28.5
TWYFORDS 11006 'Back Inlet' S-Trap W.C. Pan.	(10/87). * (10/102).	↓	UN-VENTED VENTED	2.1431 1.9937	0.0673 0.0607	31.8 32.8	1.980 1.980	0.060 0.060	33.0 33.0

C1, C2 and C3, where:- $V = C1 - C2 \cdot \sqrt{L/G}$, and $C3 = C1/C2$. Original Researcher, - * Wakelin (1978). ** Marriott (1979).

FIGURE 10/88. - SUMMARY OF WORKS RELATING TO THE EFFECTS, UPON 'MODEL' SOLID TRANSPORT, OF VARIATIONS IN W.C. TYPE AND VENT CONDITION.

10/89. - A). Back of W.C. Pan
Facing the
Direction of Flow.

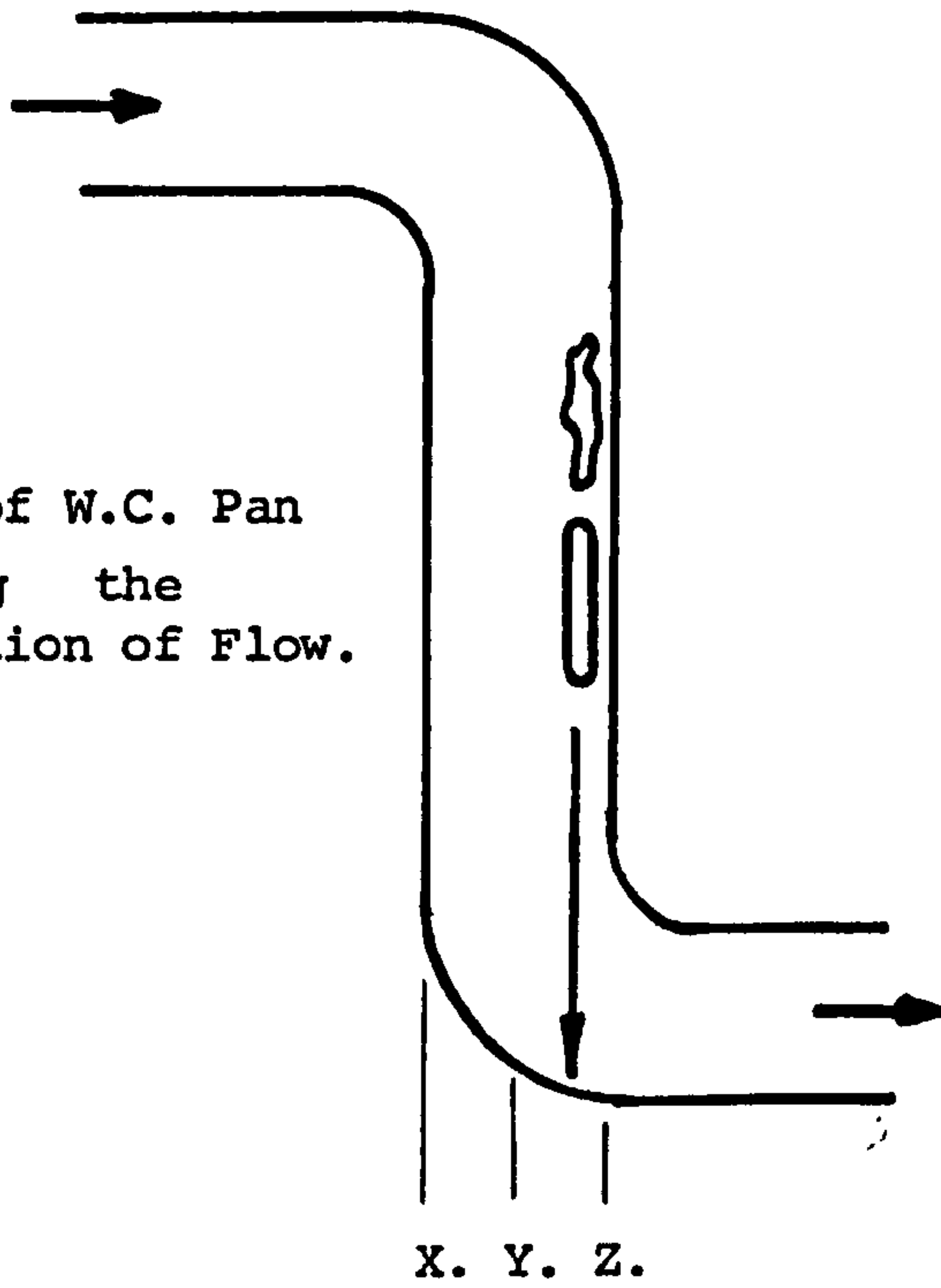

10/89. - B). Front of W.C. Pan
Facing the
Direction of Flow.

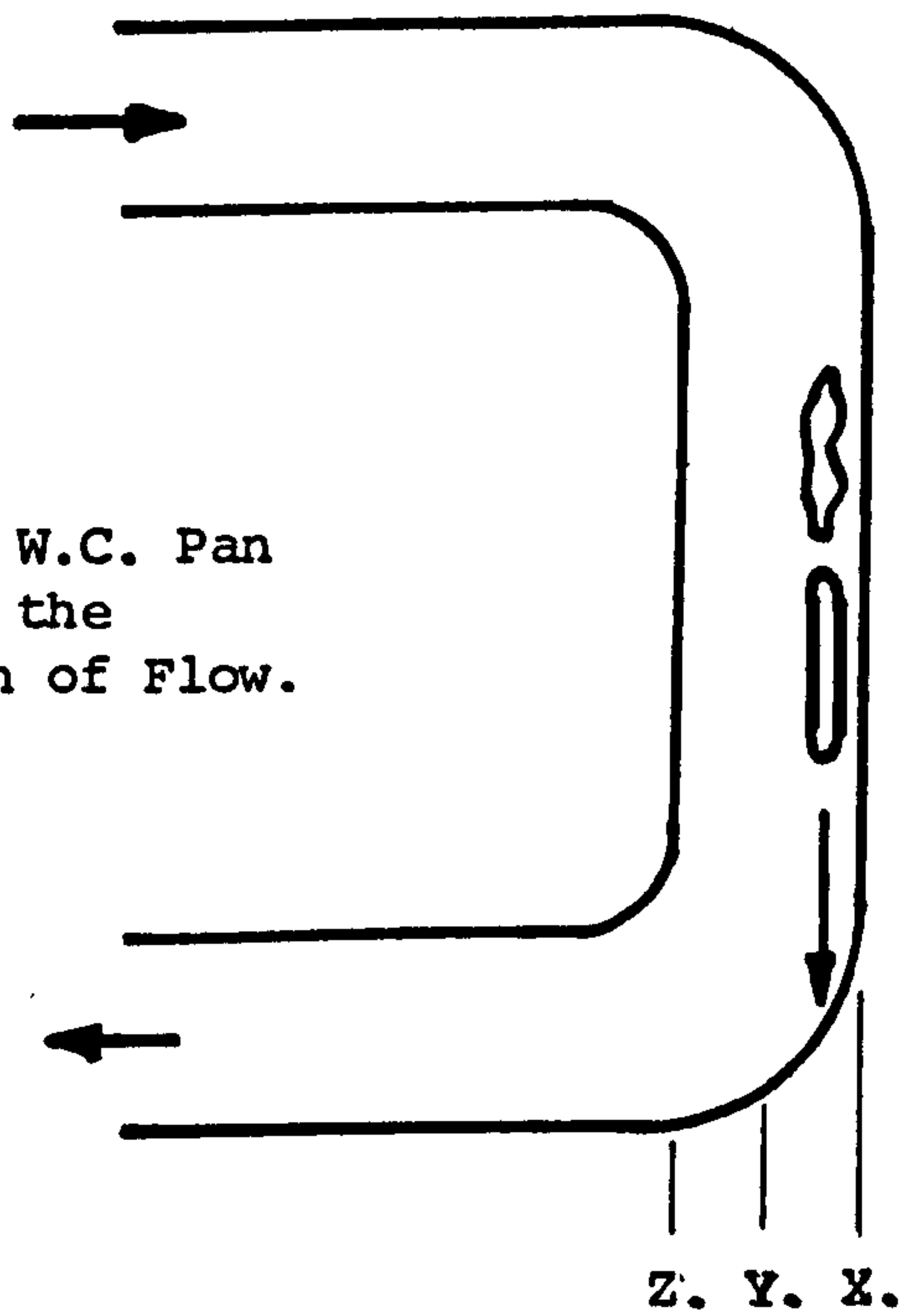

FIGURE 10/89. - W.C. Orientation and Waste Solid Transport.

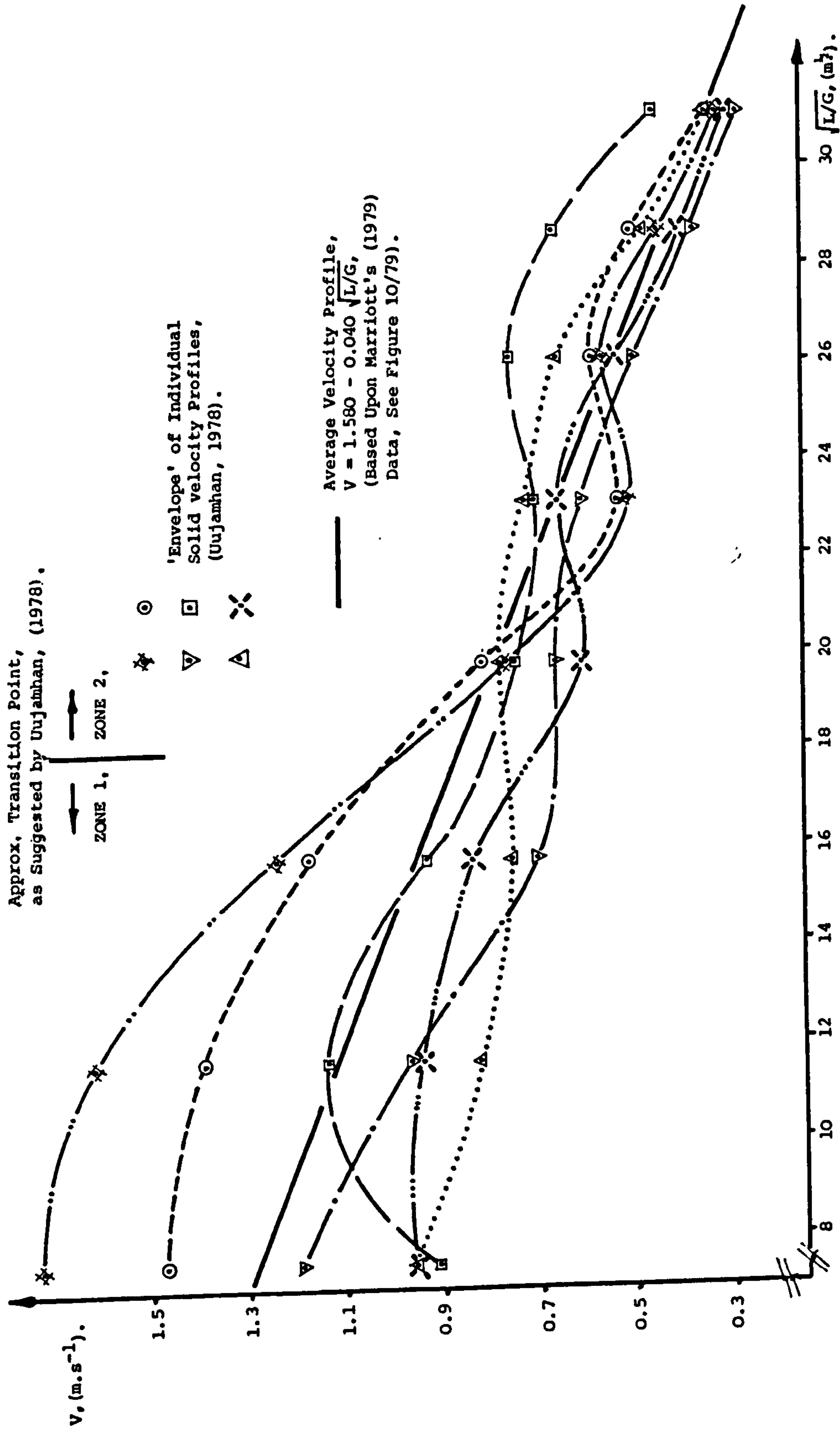

FIGURE 10/90. - INDIVIDUAL 'ZONE 1.' SOLID VELOCITY PROFILES OF 'MATERNITY PADS', AS RECORDED IN THE LABORATORY AT GRADIENT 1:80, - all data recorded using a Twyford's Euro. Reg. 'Back entry', p-trap W.C. pan.

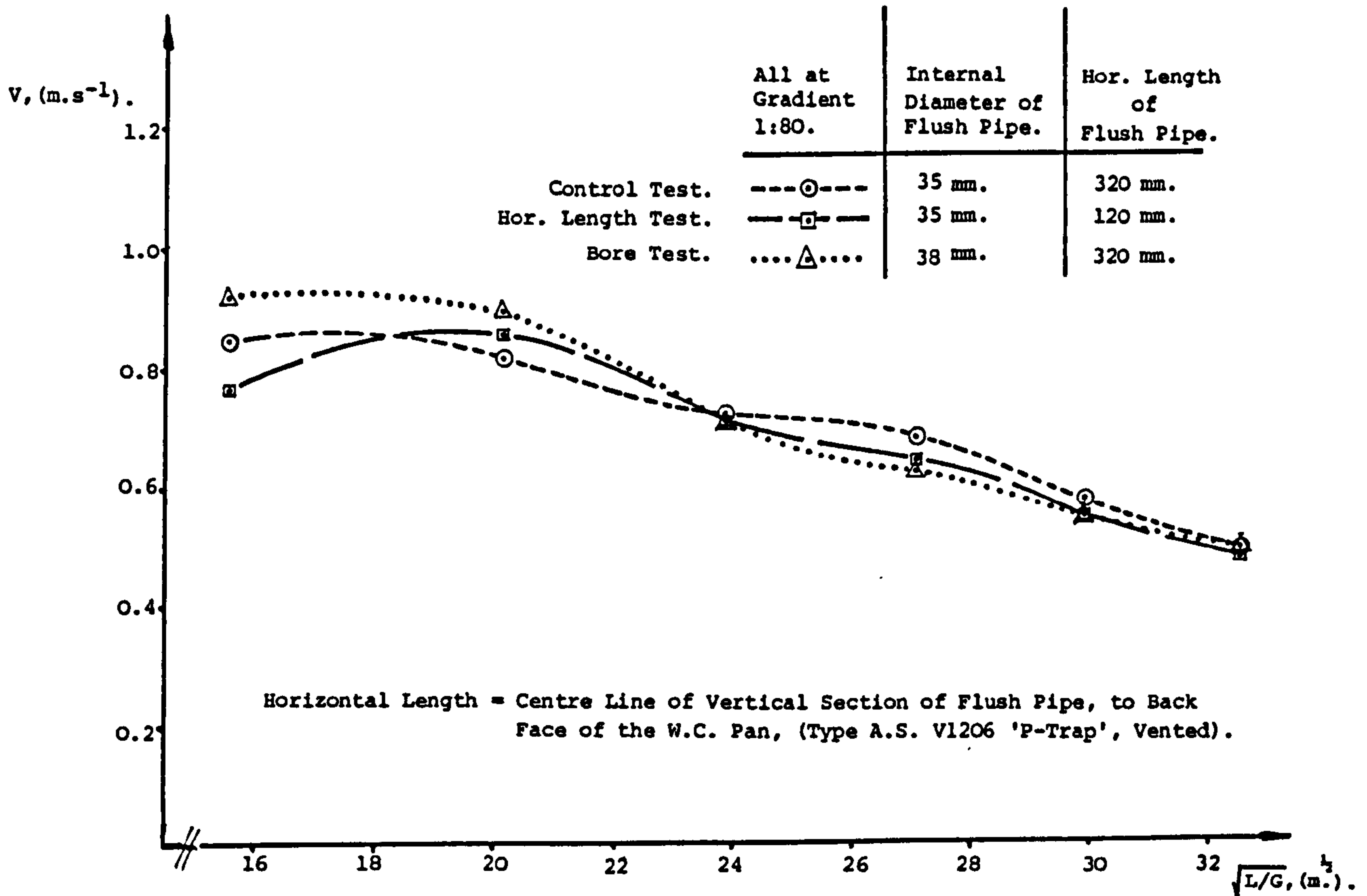

FIGURE 10/91. - W.C./CISTERN GEOMETRY, - AVERAGE VELOCITY PROFILES FOR EACH OF THE 'CONTROL', 'HORIZONTAL LENGTH' (OF FLUSH PIPE), AND 'BORE' (OF FLUSH PIPE), TESTS'.

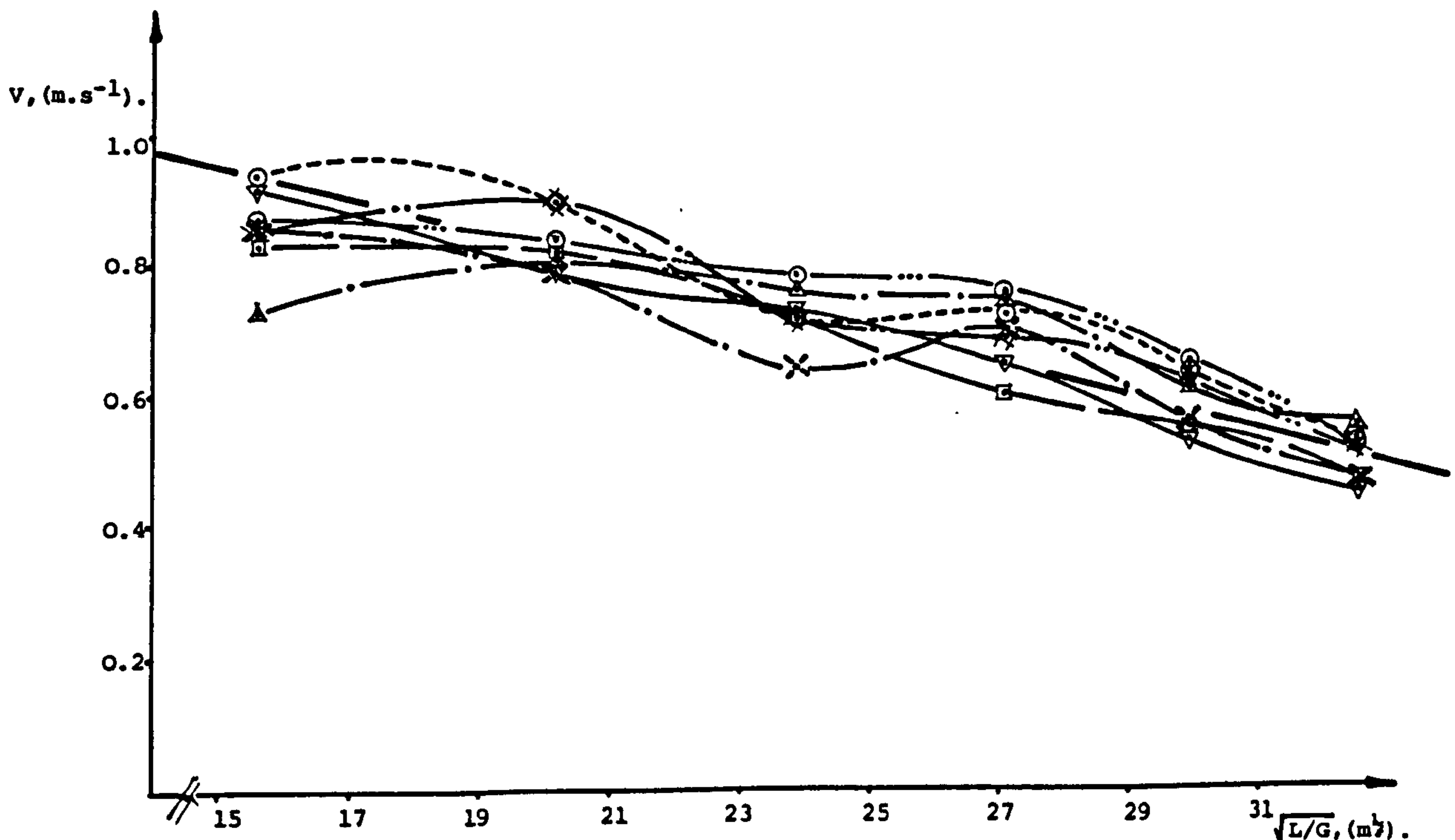

FIGURE 10/92. - W.C./CISTERN GEOMETRY, - A RANGE OF INDIVIDUAL 'MODULATIVE' SOLID VELOCITY PROFILES, AS COMPONENT TO THE 'CONTROL' TEST.

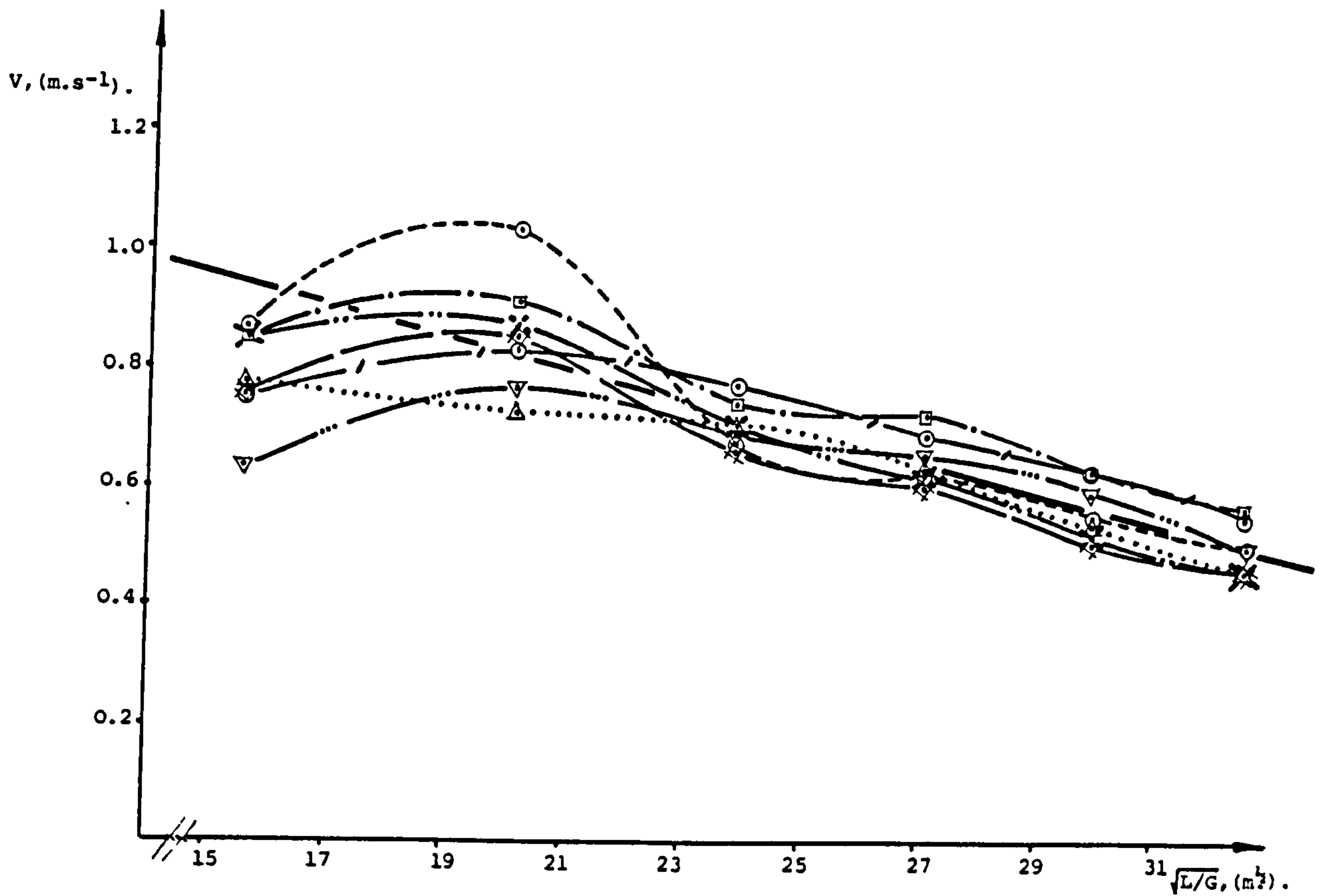

FIGURE 10/93. - W.C./CISTERN GEMOETRY, - A RANGE OF INDIVIDUAL 'MODULATIVE' SOLID VELOCITY PROFILES, AS COMPONENT TO THE 'HORIZONTAL LENGTH' (OF FLUSH PIPE), TEST.

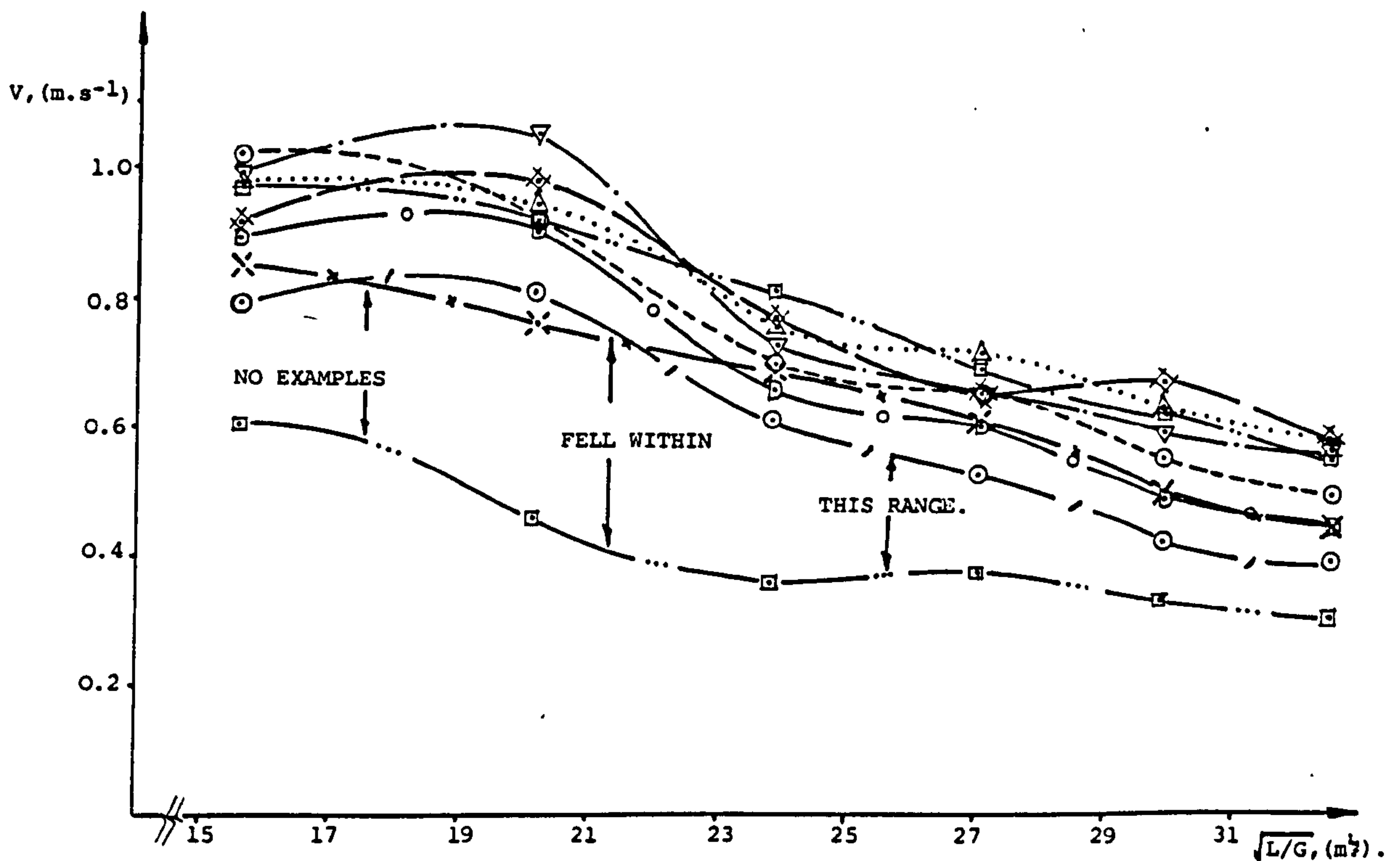

FIGURE 10/94. - W.C./CISTERN GEMOETRY, - A RANGE OF INDIVIDUAL 'MODULATIVE' SOLID VELOCITY PROFILES, AS COMPONENT TO THE 'BORE' (OF FLUSH PIPE), TEST.

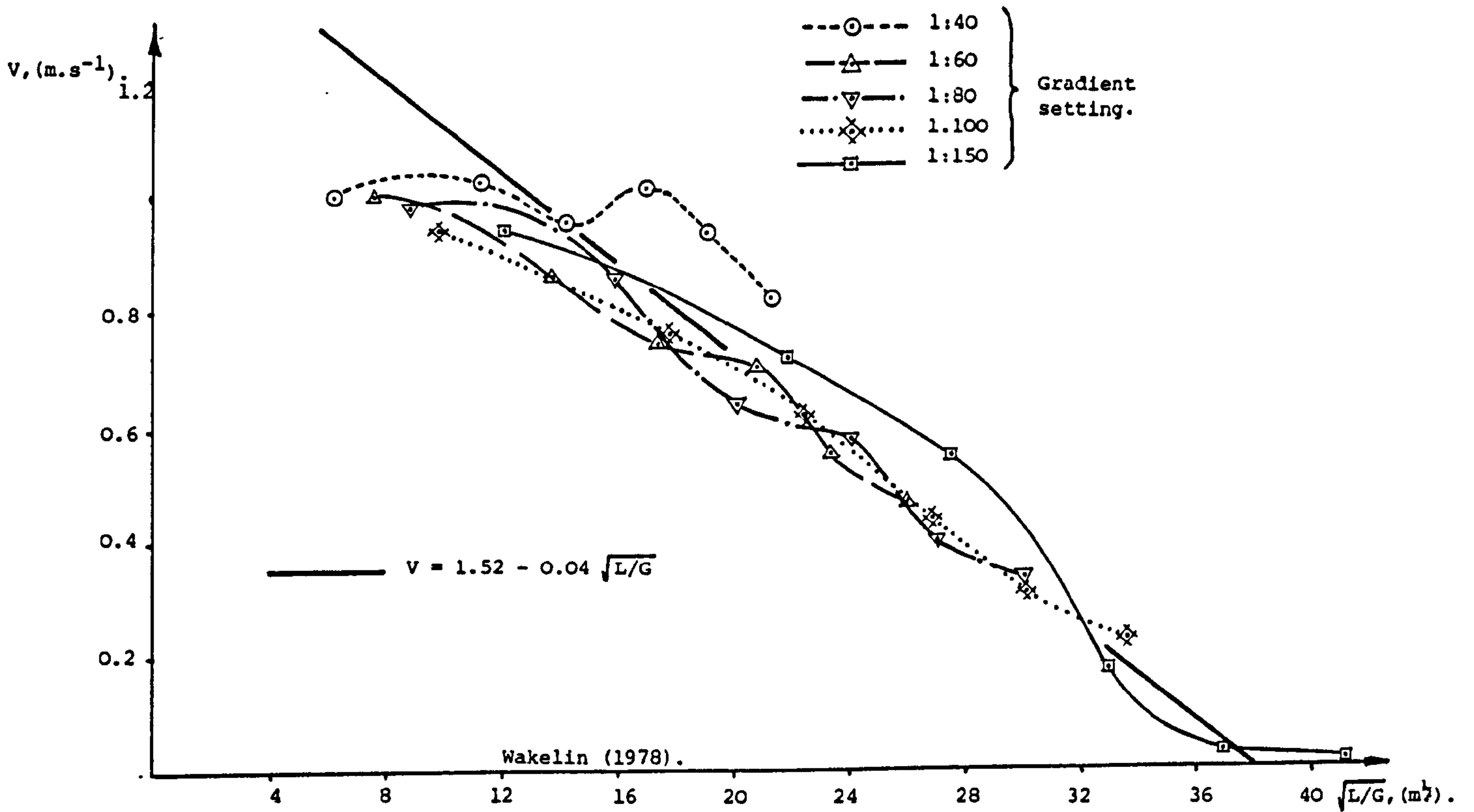

FIGURE 10/95. - AVERAGE 'MATERNITY PAD' VELOCITY PROFILES, AS RECORDED, OVER A RANGE OF DIFFERENT GRADIENTS USING A VENTED ARMITAGE SHANKS 'P-TRAP' W.C. PAN.

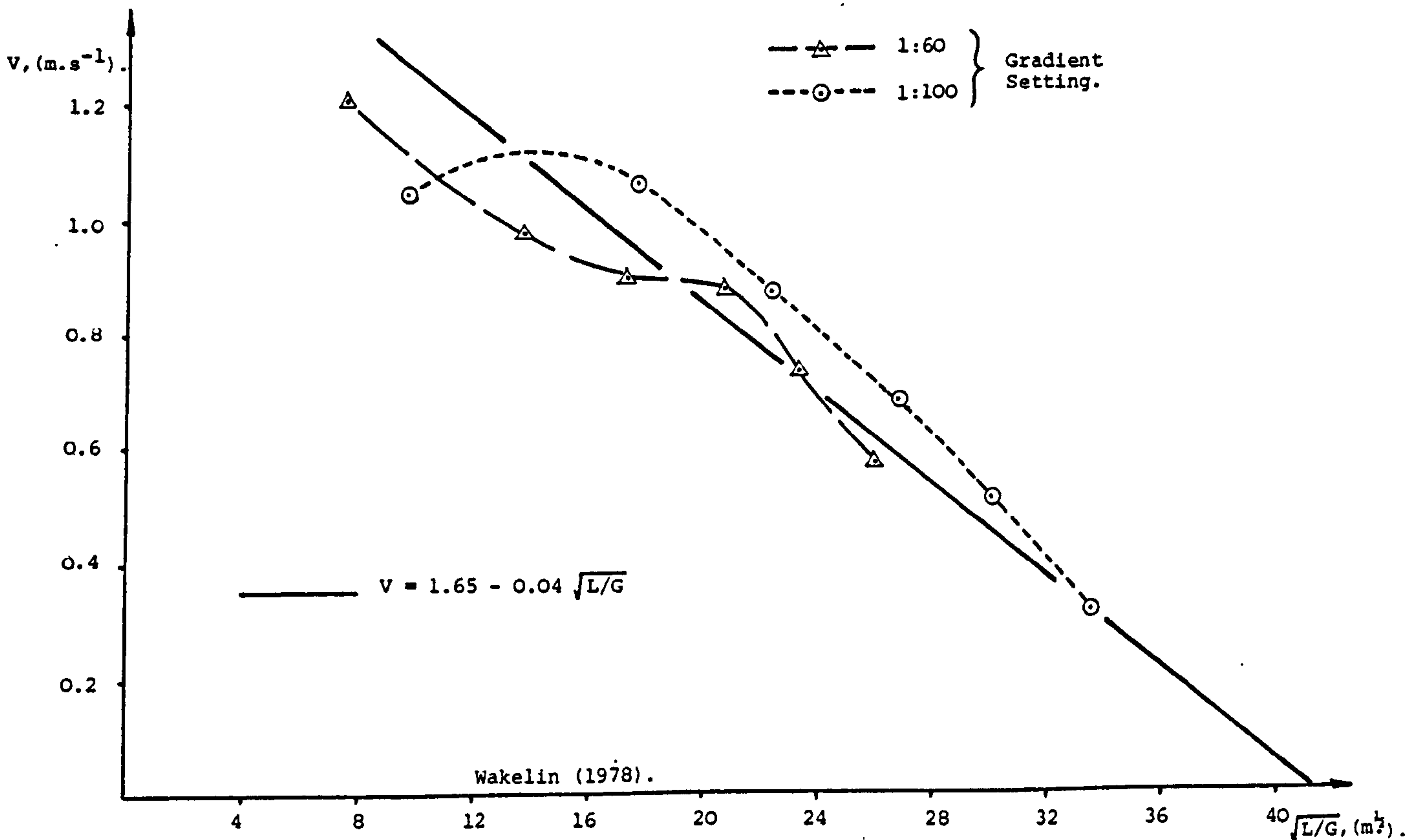

FIGURE 10/96. - AVERAGE 'MATERNITY PAD' VELOCITY PROFILES, AS RECORDED, AT GRADIENTS 1:60 AND 1:100, USING A VENTED ARMITAGE SHANKS 'S-TRAP' W.C. PAN.

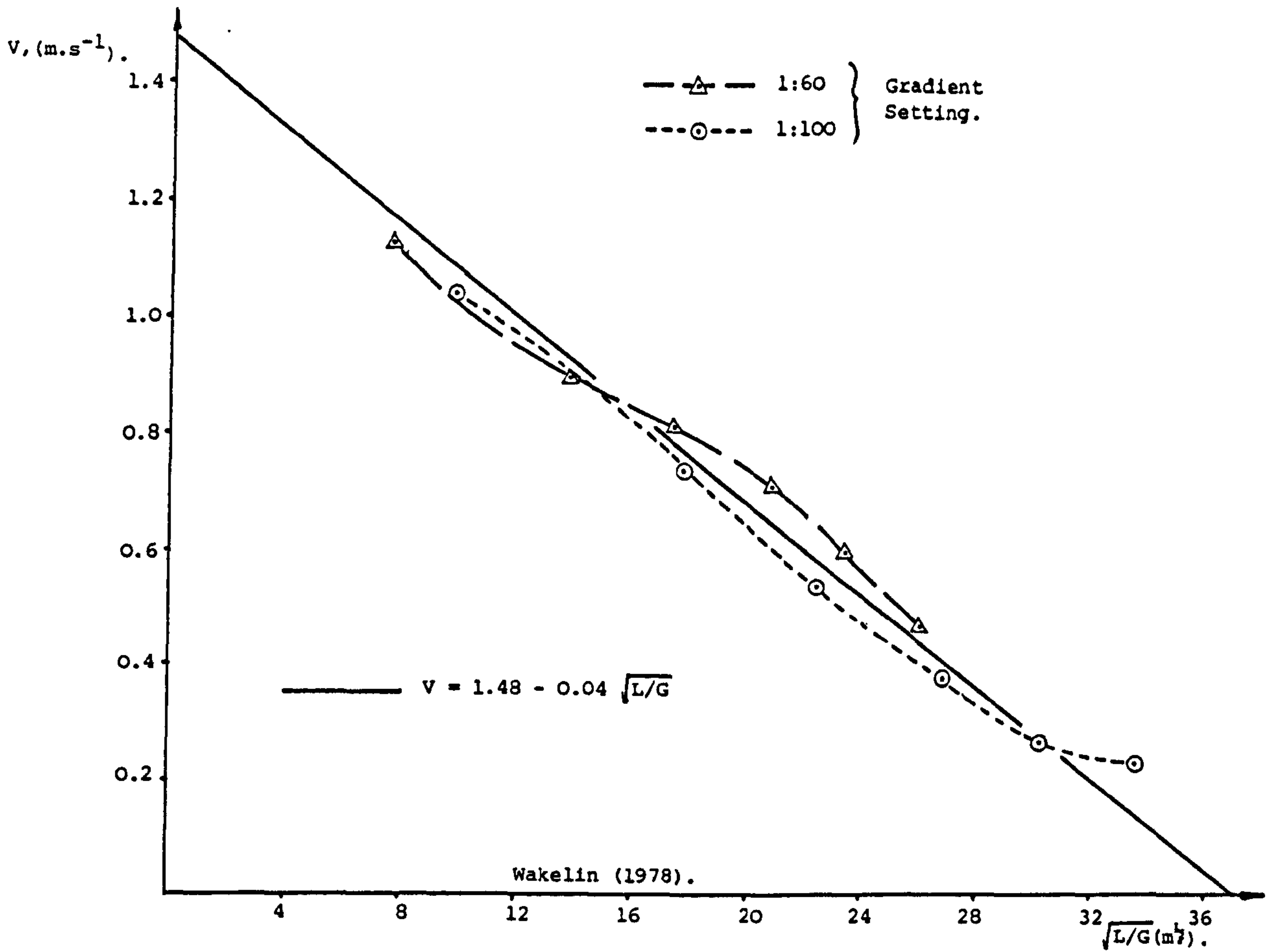

FIGURE 10/97. - AVERAGE 'MATERNITY PAD' VELOCITY PROFILES, AS RECORDED, AT GRADIENTS 1:60 AND 1:100, USING A VENTED TWYFORDS 'P-TRAP' W.C. PAN.

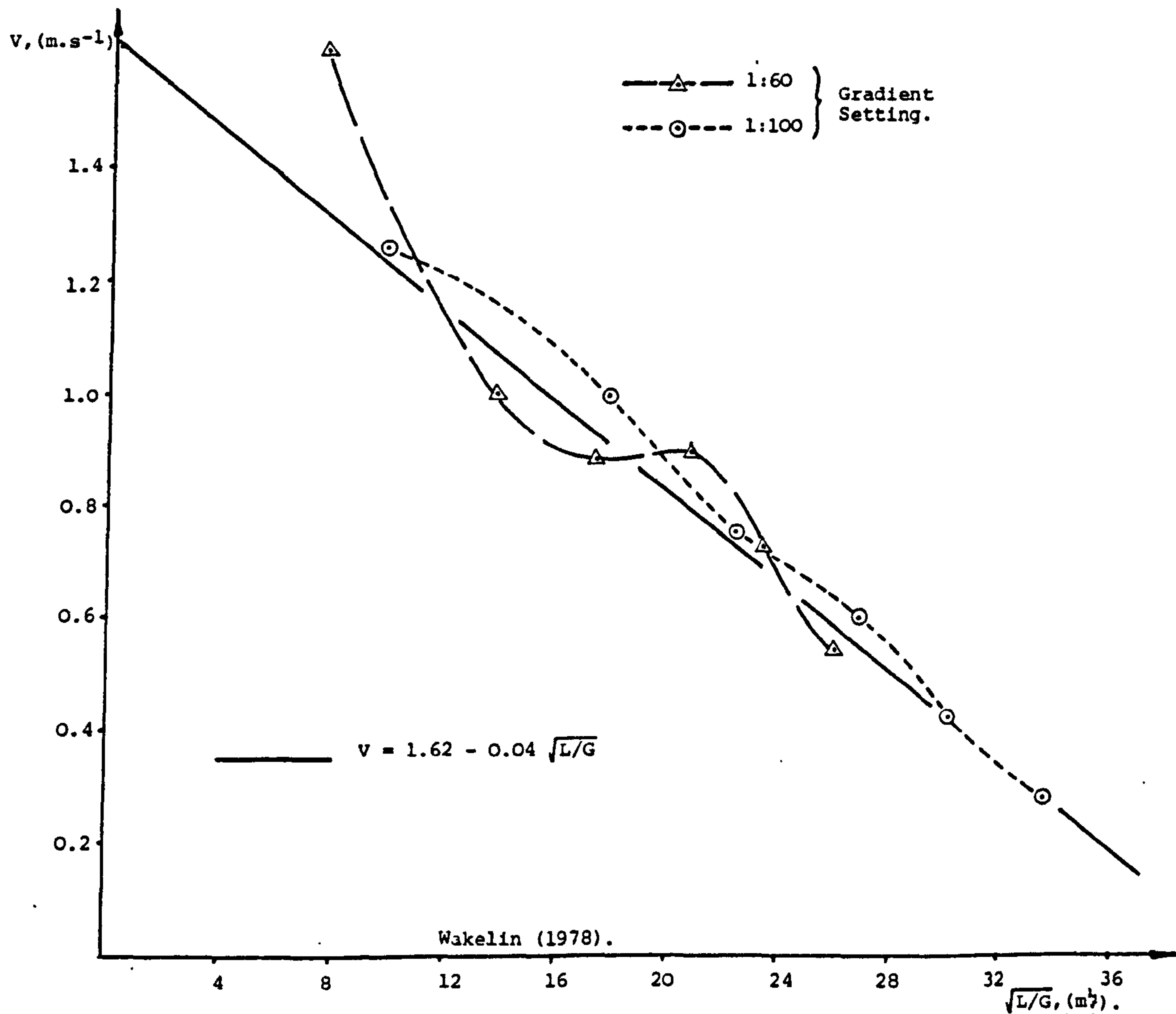

FIGURE 10/98. - AVERAGE 'MATERNITY PAD' VELOCITY PROFILES, AS RECORDED, AT GRADIENTS 1:60 AND 1:100, USING A VENTED TWYFORDS 'S-TRAP' W.C. PAN.

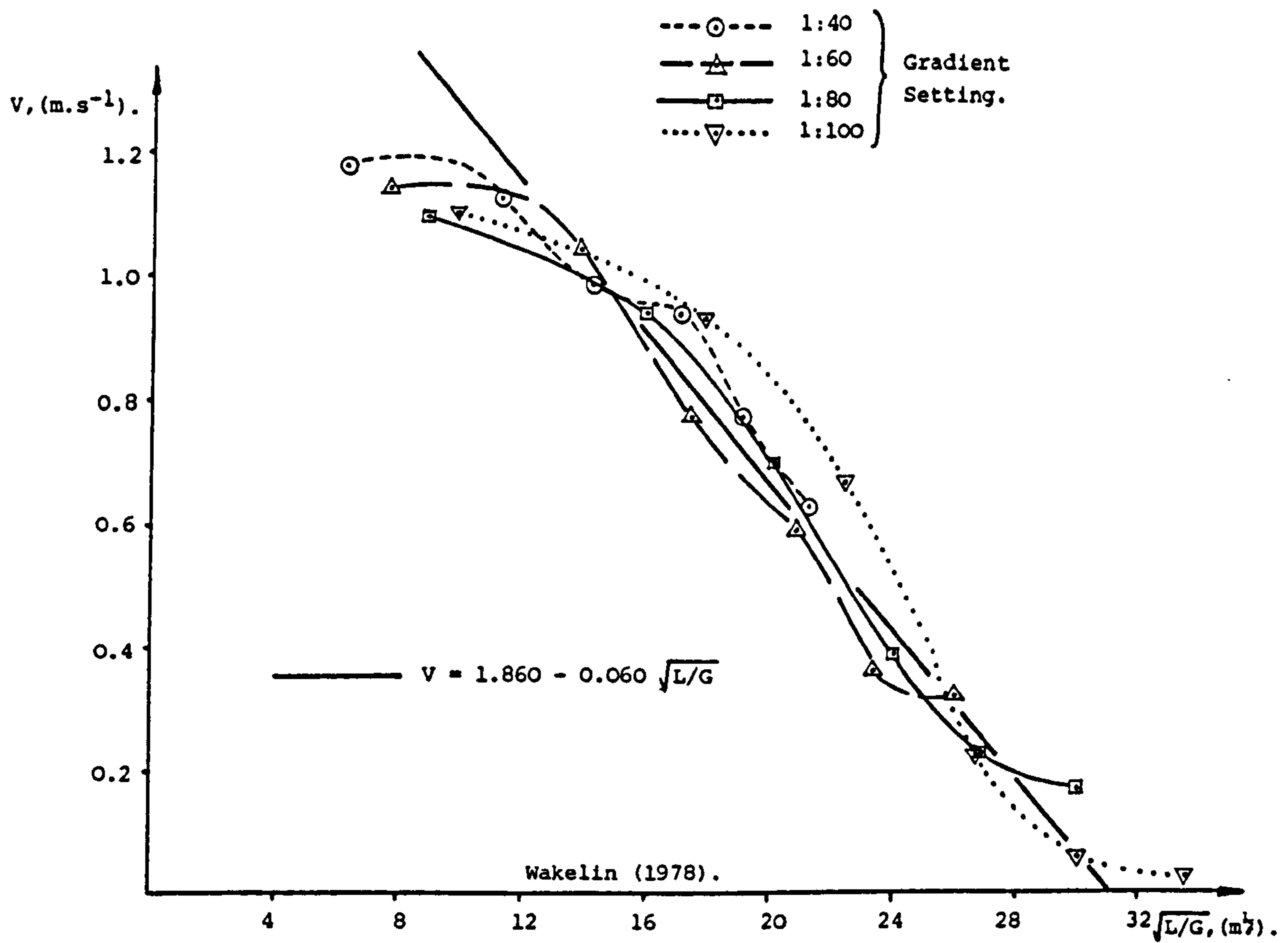

FIGURE 10/99. - AVERAGE VELOCITY PROFILES OF THE 'MATERNITY PAD & 3. KLEENEX TOWEL' WASTE LOAD, AS RECORDED, OVER A RANGE OF DIFFERENT GRADIENTS, USING A VENTED ARMITAGE SHANKS 'P-TRAP' W.C. PAN.

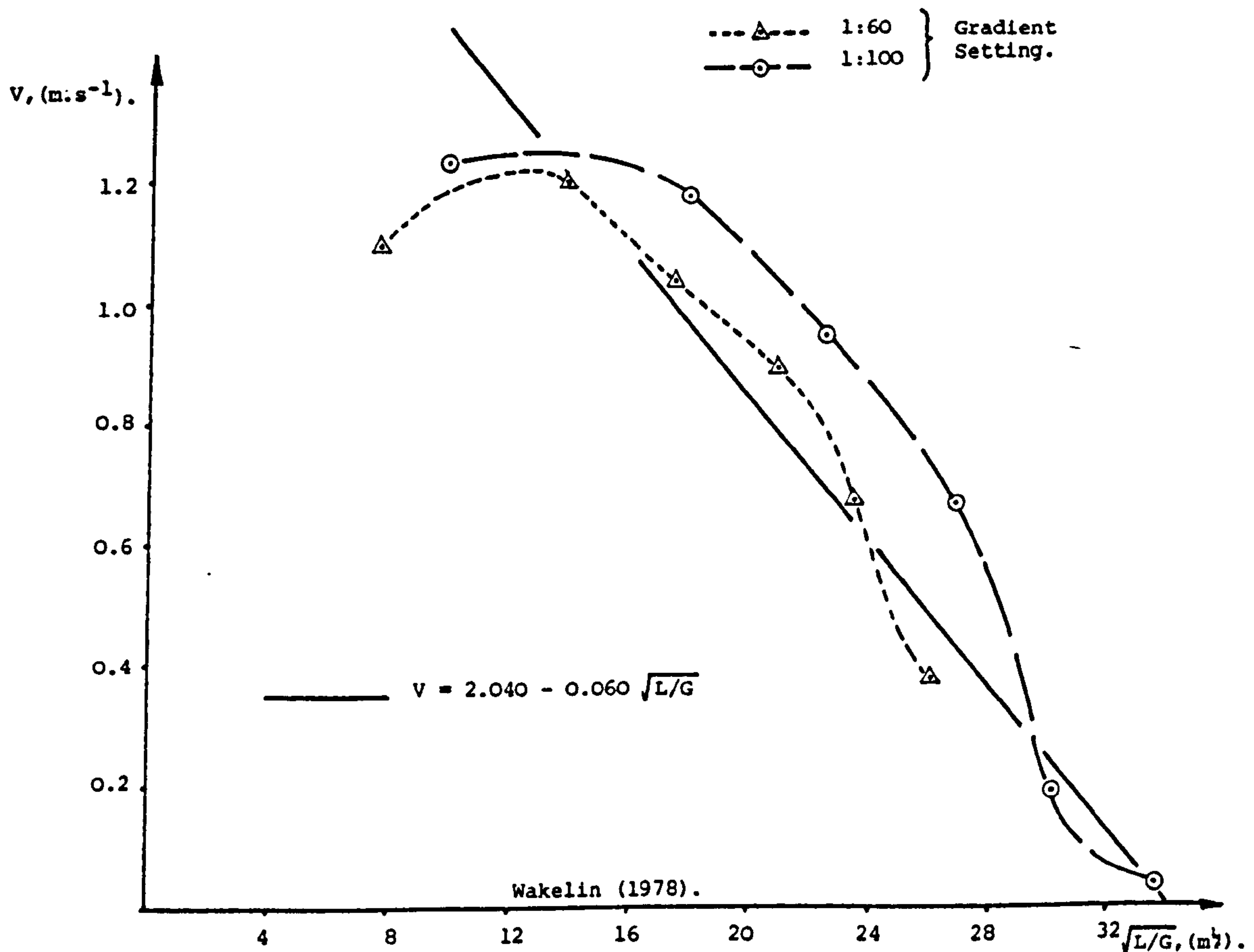

FIGURE 10/100. - AVERAGE VELOCITY PROFILES OF THE 'MATERNITY PAD & 3. KLEENEX TOWEL' WASTE LOAD, AS RECORDED, AT GRADIENTS 1:60 AND 1:100, USING A VENTED ARMITAGE SHANKS 'S-TRAP' W.C. PAN.

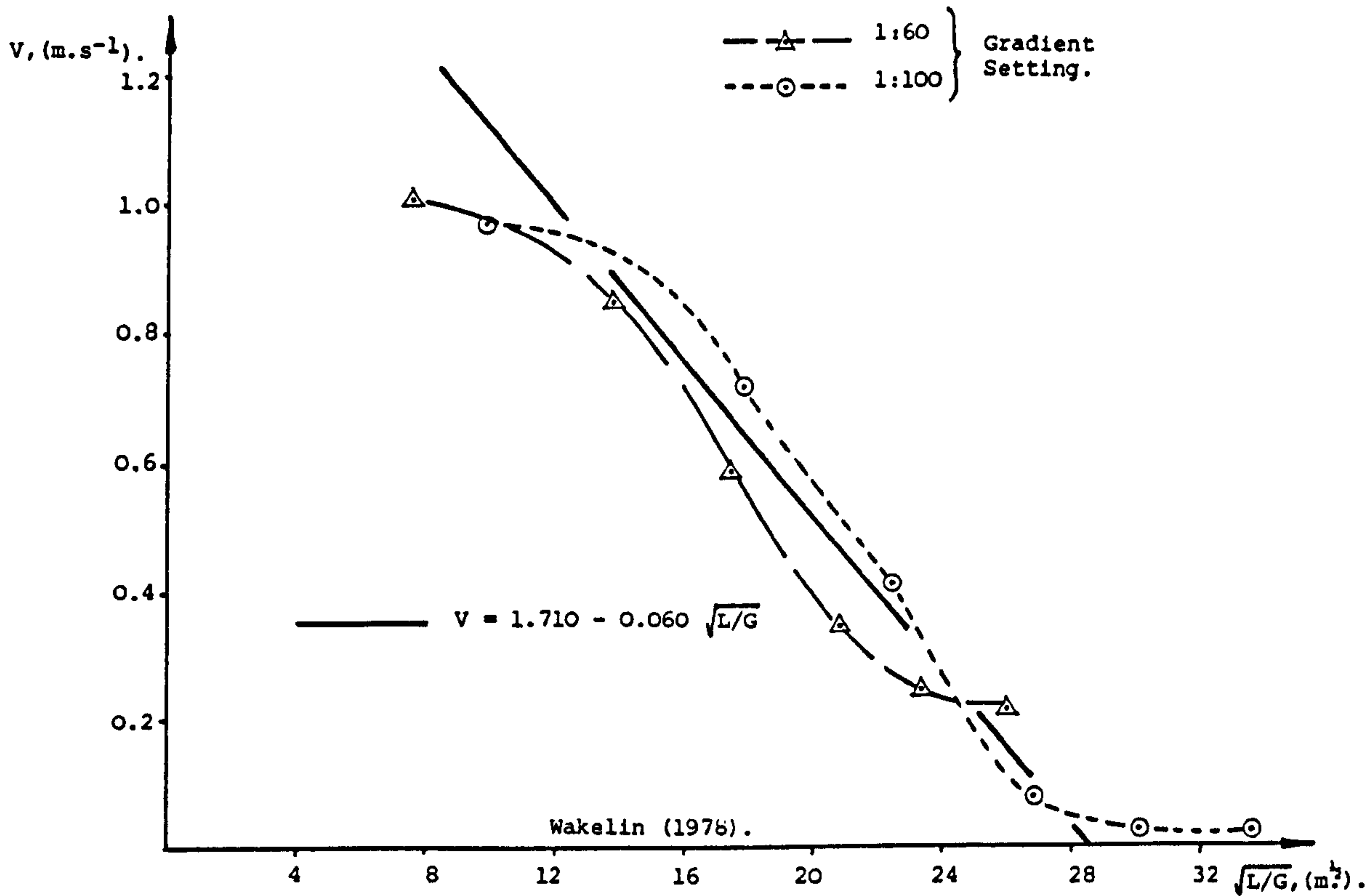

FIGURE 10/101. - AVERAGE VELOCITY PROFILES OF THE 'MATERNITY PAD & 3. KLEENEX TOWEL' WASTE LOAD, AS RECORDED, AT GRADIENTS 1:60 AND 1:100, USING A VENTED TWYFORDS 'P-TRAP' W.C. PAN.

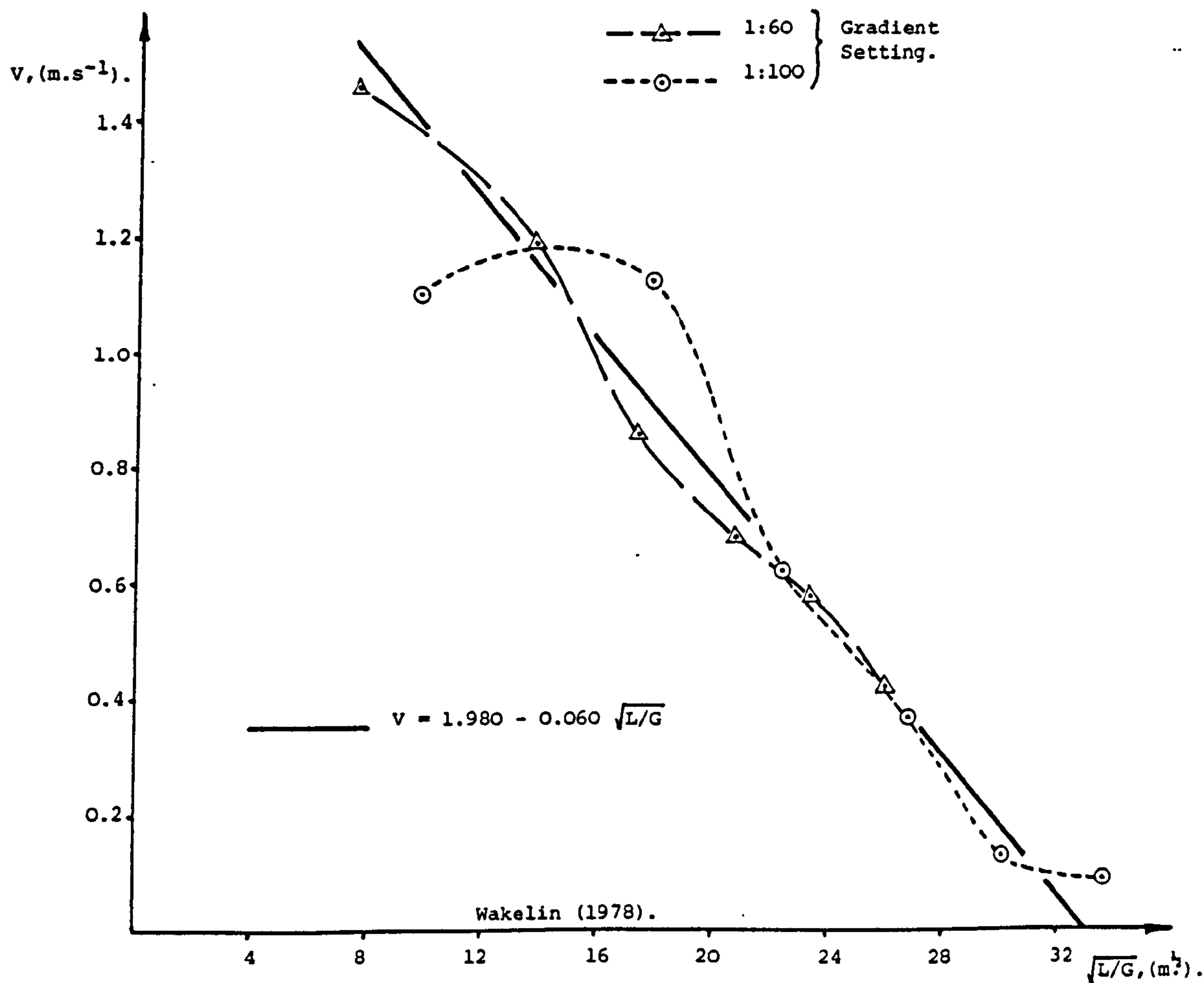

FIGURE 10/102. - AVERAGE VELOCITY PROFILES OF THE 'MATERNITY PAD & 3. KLEENEX TOWEL' WASTE LOAD, AS RECORDED, AT GRADIENTS 1:60 AND 1:100, USING A VENTED TWYFORDS 'S-TRAP' W.C. PAN.

	Variation in 'C3', (%), as a Consequence of Venting the W.C. Discharge.		Variation in the Amount of Water Behind the Average Solid, (%), as a Consequence of Venting the W.C. Discharge.		Variation in the Standard Deviation of Velocity, (%), (Averaged Over the Six Different Velocity Measurement Points), as a Consequence of Venting the W.C. Discharge.		
	SINGLE MATERNITY PAD SOLID.	MATERNITY PAD & 3 KLEENEX TOWELS.	SINGLE MATERNITY PAD SOLID.	MATERNITY PAD & 3 KLEENEX TOWELS.	SINGLE MATERNITY PAD SOLID.	MATERNITY PAD & 3 KLEENEX TOWELS.	
ARMITAGE SHANKS V1206 'back-inlet', P-trap, W.C. pan.	1/60 1/100	-3.31	-4.62	-6.47	-0.55	+59.05	-5.97
ARMITAGE SHANKS V1206 'back inlet', S-Trap, W.C. pan.	1/60 1/100	-0.24	NONE.	-11.03	+1.69	+33.37	-11.67
TWYFORDS 11006 'back-inlet', P-trap W.C. pan.	1/60 1/100	+2.49	+3.64	+1.11	-4.31	+1.44	+0.24
TWYFORDS 11006 'back-inlet', S-trap W.C. pan.	1/60 1/100	-0.25	NONE.	+1.79	+0.44	+13.75	+27.00
				-0.91	+1.29	-31.17	+2.47
				-6.10	+2.55	-7.95	+35.07
				-5.13	-0.74	+7.11	+32.66
				-6.51	-4.36	+19.54	-20.59

FIGURE 10/103. - Summary of the Effects of 'Venting' W.C. Discharge.

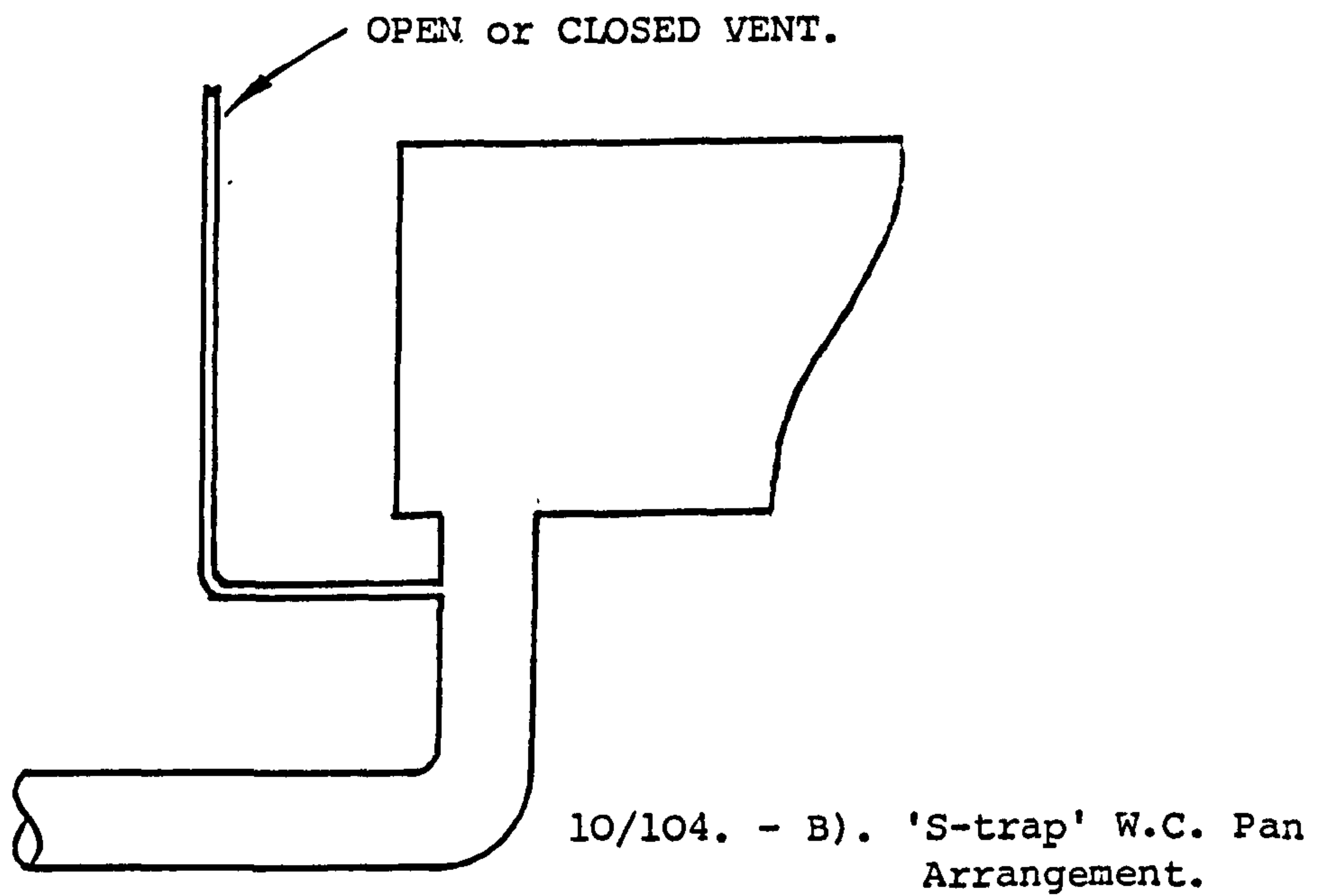
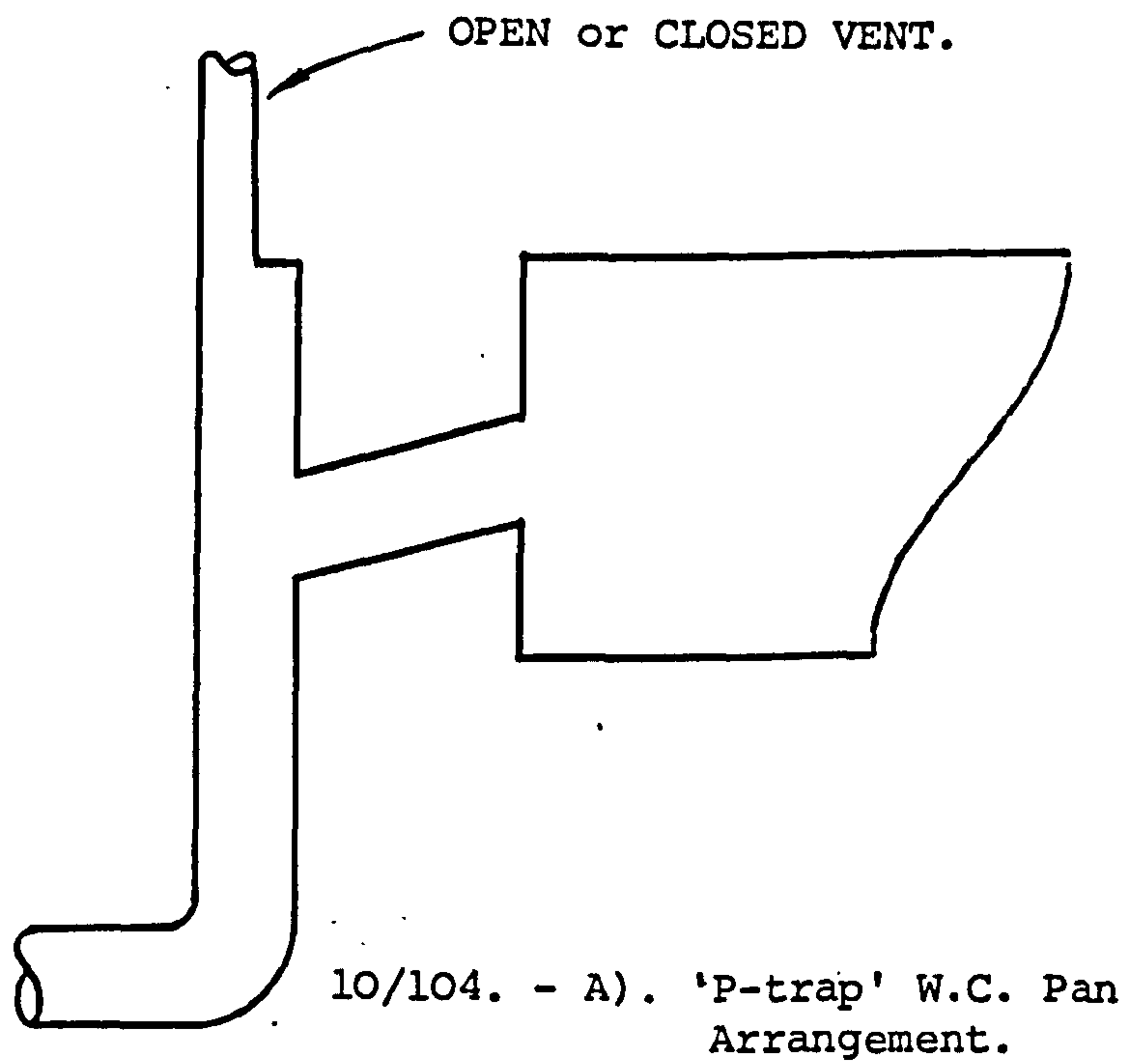

FIGURE 10/104. - The Venting Configurations Employed by Wakelin (1978).

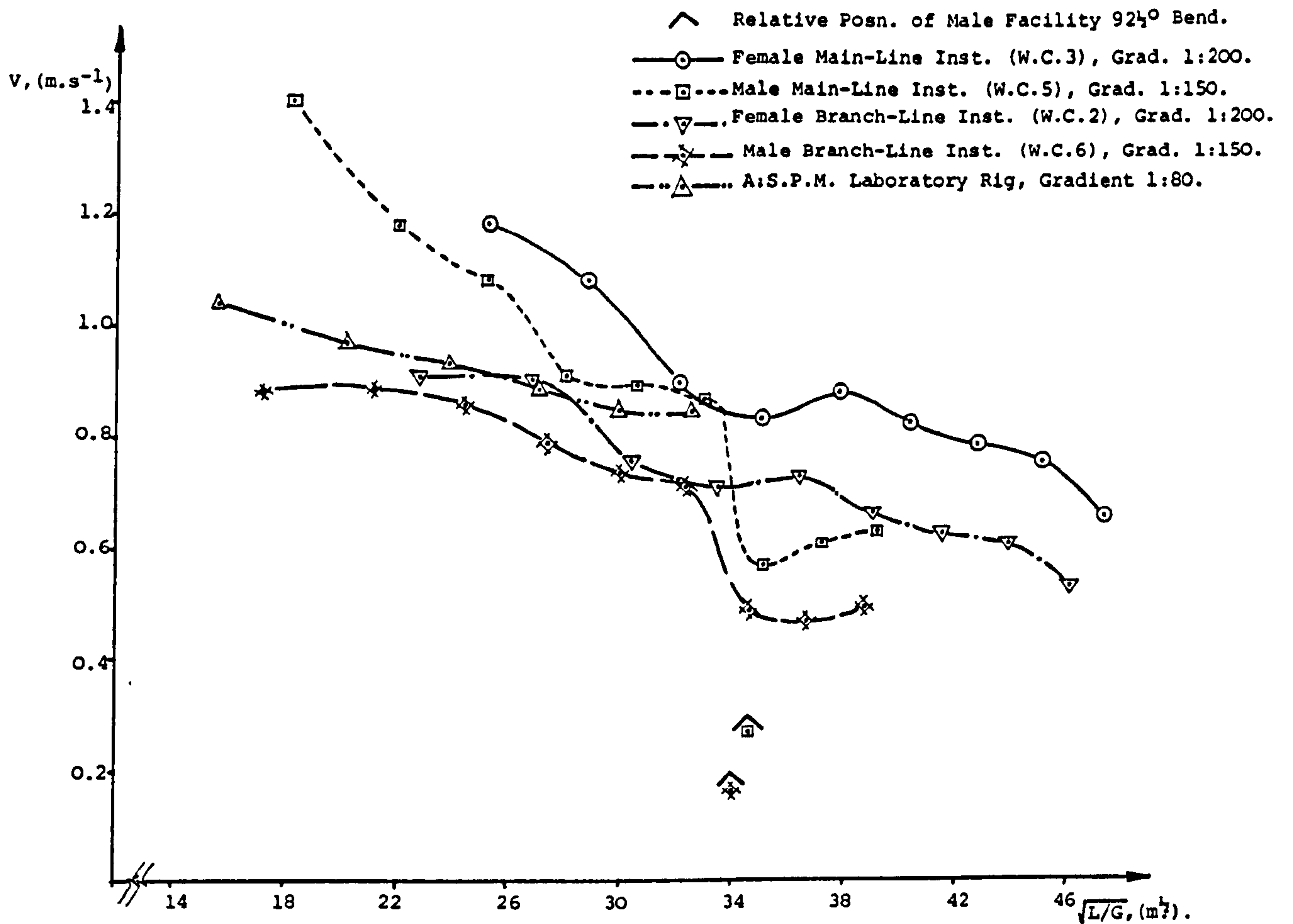

FIGURE 10/105. - AVERAGE 'JOHNSON & JOHNSON PANTY SHIELD' VELOCITY PROFILES, AS RECORDED DURING 'INSTALLED SYSTEM' CALIBRATION PROCEDURES.

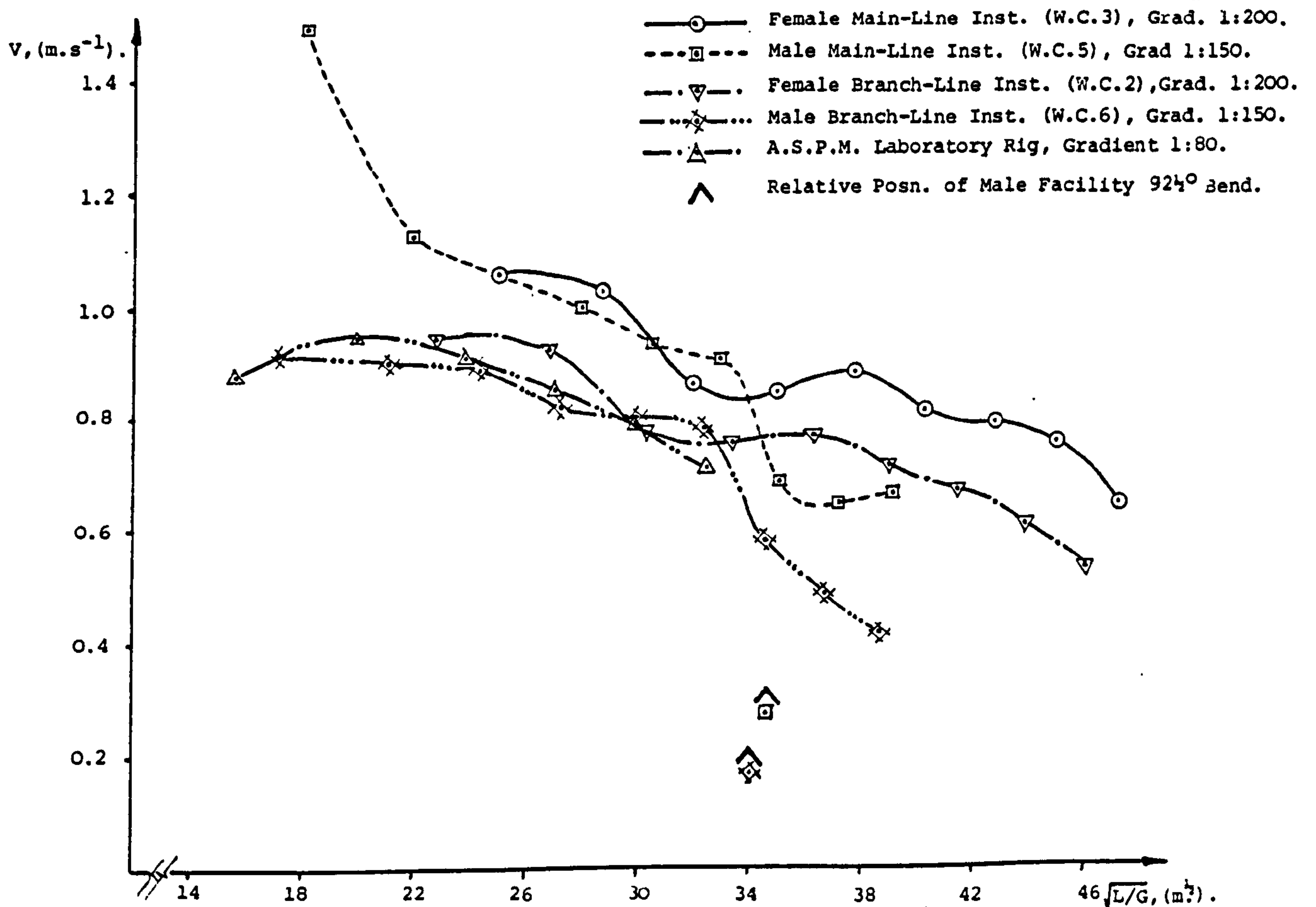

FIGURE 10/106. - AVERAGE 'FASTIDIA MINI-PAD' VELOCITY PROFILES, AS RECORDED DURING 'INSTALLED SYSTEM' CALIBRATION PROCEDURES.

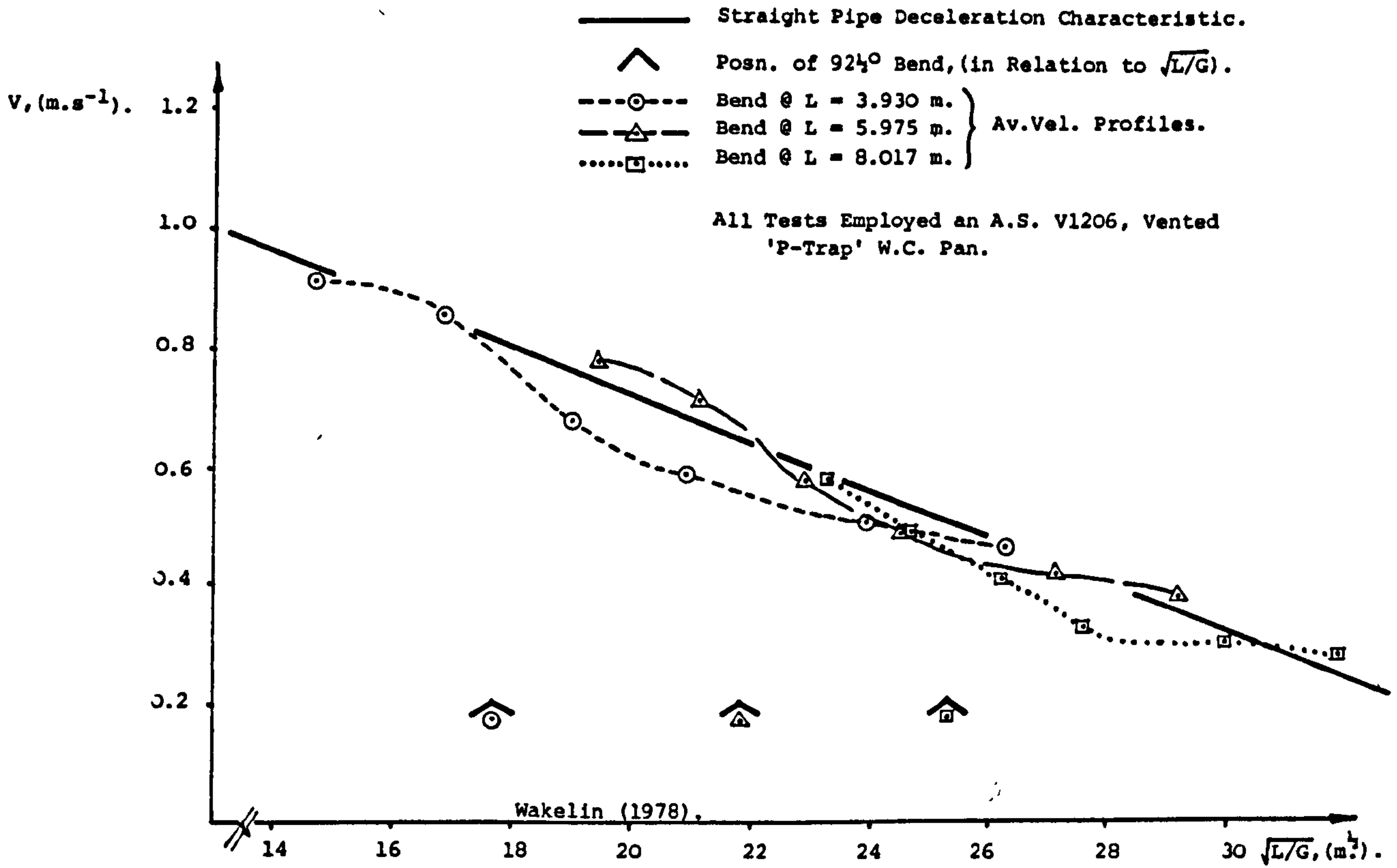

FIGURE 10/107. - AVERAGE 'MATERNITY PAD' VELOCITY PROFILES, AS RECORDED, AT GRADIENT 1:80, DURING LABORATORY BASED INVESTIGATIONS OF THE EFFECTS OF AN INCORPORATED 92½° BEND.

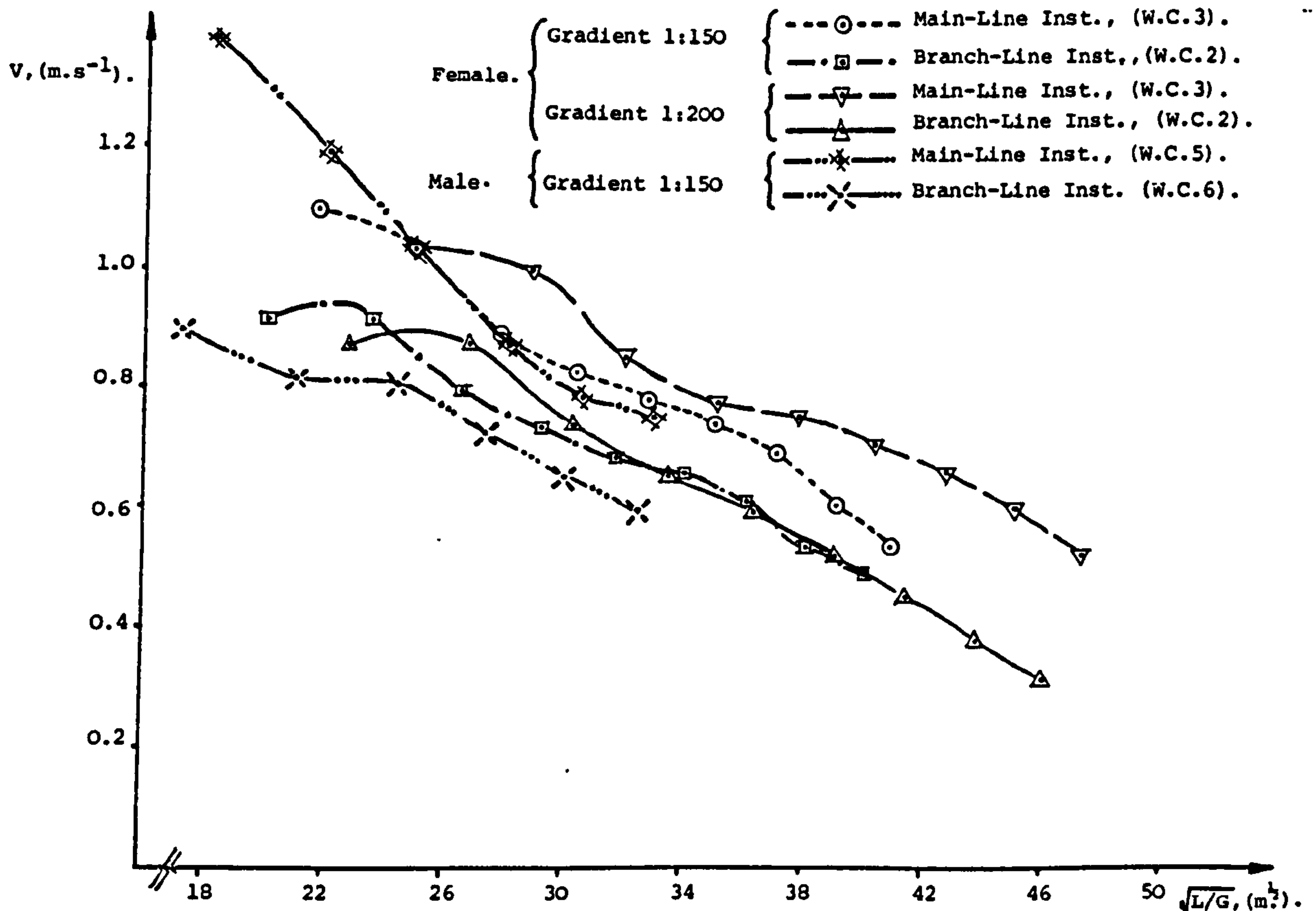

FIGURE 10/108. - AVERAGE 'TRAILING SOLID' VELOCITY PROFILES OF 'NON-FAECAL' FLUSHES, AS RECORDED AT THE 'IN SITU' INSTALLATIONS.

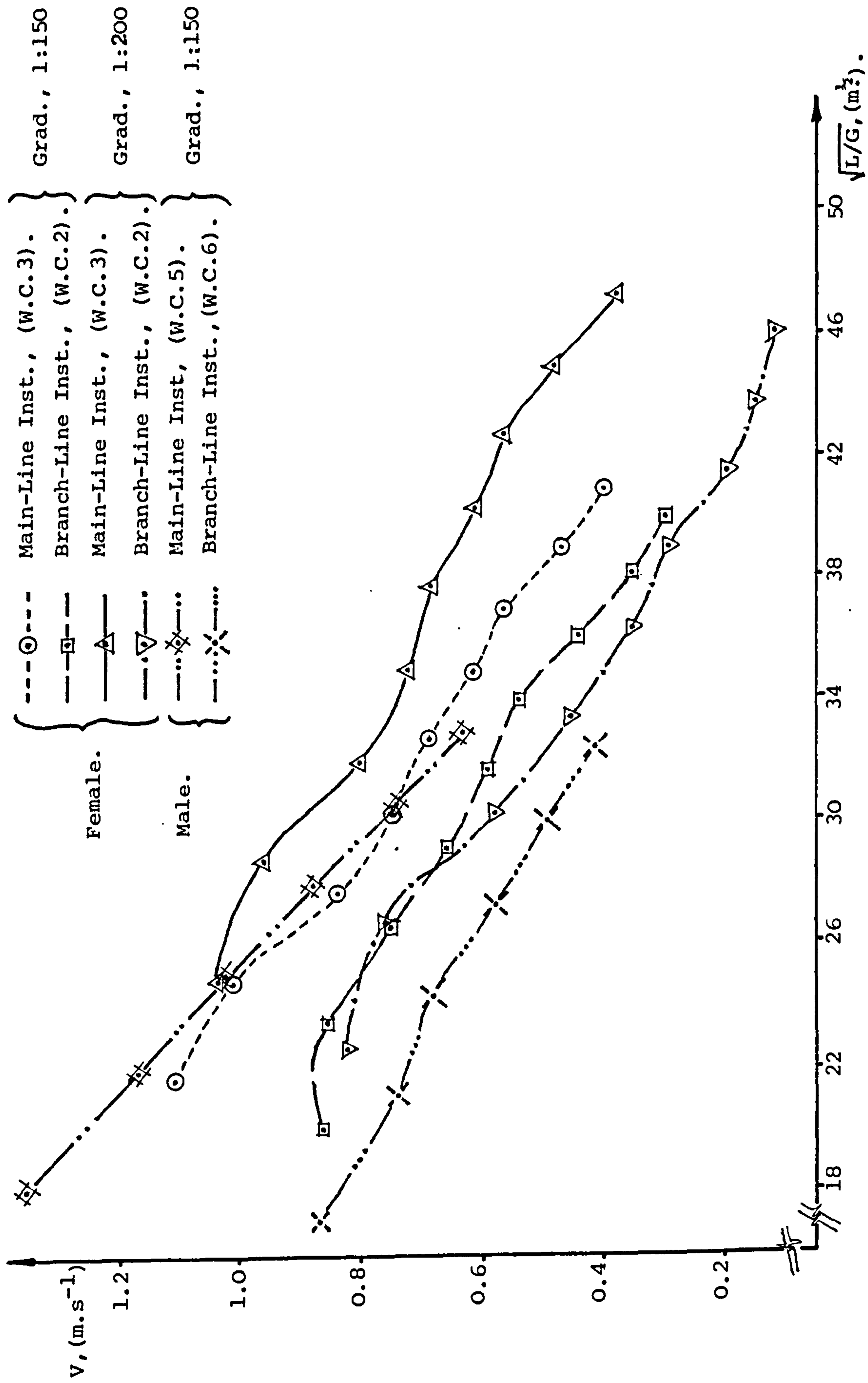

FIGURE 10/109. - AVERAGE 'TRAILING SOLID' VELOCITY PROFILES OF 'FAECAL' FLUSHES, AS RECORDED AT THE 'IN SITU' INSTALLATIONS.

				MEAN NUMBER OF TOILET/ TISSUE- PAPER SOLIDS PER FLUSH.	MEAN NUMBER OF OTHER NON- FAECAL SOLIDS PER FLUSH.	MEAN NUMBER OF FAECAL SOLIDS PER FLUSH.	MEAN TOTAL NUMBER OF SOLIDS PER FLUSH.	MEAN LENGTH OF INDIVID- UAL TOILET/ TISSUE- PAPER SOLIDS. (mm).	MEAN LENGTH OF TOILET/ TISSUE- PAPER MATERIAL PER FLUSH. (mm).	MEAN LENGTH OF ALL NON- FAECAL MATERIAL PER FLUSH. (mm).	MEAN THICKNESS OF INDIVID- AL TOILET/ TISSUE- PAPER SOLIDS (SCALAR).	NUMBER OF FLUSHES PER TEST SAMPLE.
FEMALE FACILITY	'FAECAL' WASTE LOADS	'MAIN- LINE' (W.C.3).	1:150	1,127	0,018	1,855	3,000	236	266	271	3.226	55
			1:200	1,375	0,063	2,281	3,719	181	248	260	3.364	32
		'BRANCH- LINE' (W.C.2).	1:150	1,306	0,000	1,639	2,994	231	301	301	3,255	36
			1:200	1,459	0,000	2,676	4,135	217	317	317	3.241	37
	'NON FAECAL' WASTE LOADS.	'MAIN- LINE' (W.C.3).	1:150	1,189	0,065	-	1,254	185	220	232	3.178	307
			1:200	1,207	0,015	-	1,222	208	251	254	3.371	261
		'BRANCH- LINE' (W.C.2).	1:150	1,101	0,078	-	1,178	184	200	216	3.236	258
			1:200	1,197	0,014	-	1,211	190	228	230	3.259	284
MALE FACILITY	'FAECAL' WASTE LOADS.	'MAIN-LINE' (W.C.5).		1,391	0,031	2,047	3,469	196	273	279	3.034	64
		'BRANCH-LINE' (W.C.6).		1,554	0,000	2,723	4,277	195	303	303	3.103	112
	'NON- FAECAL' WASTE LOADS.	'MAIN-LINE' (W.C.5).		1,632	0,053	-	1,684	179	293	307	2.968	38
		'BRANCH-LINE' (W.C.6).		1,563	0,063	-	1,625	157	246	253	3.067	48

FIGURE 10/110. - SUMMARY OF USEFUL DESCRIPTIVE INFORMATION CONCERNING THE MEAN WASTE CONTENT OF EACH DISTINCT AND SEPARATE TEST SAMPLE, AS RECORDED AT THE 'IN SITU' INSTALLATIONS, OF SUCCESSFULLY MONITORED 'SINGLE' FLUSHES WHICH DID NOT ENCOUNTER PREVIOUS DEPOSITS.

	'FAECAL FLUSH' SAMPLE SIZE. (Number of Flushes).	'NON-FAECAL FLUSH' SAMPLE SIZE. (Number of Flushes).	TOTAL NUMBER OF FLUSHES INVOLVED IN COMPARISON.	MEAN 'FAECAL FLUSH' TOILET/TISSUE-PAPER 'LENGTH', AS COMPARED TO MEAN 'NON-FAECAL FLUSH' TOILET/TISSUE-PAPER 'LENGTH'.	MEAN 'FAECAL FLUSH' TOILET/TISSUE-PAPER 'THICKNESS', AS COMPARED TO MEAN 'NON-FAECAL FLUSH' TOILET/TISSUE-PAPER 'THICKNESS'.
FEMALE.	'MAIN-LINE', (1:150).	307	362	+20.91%	+1.51%
	'MAIN-LINE', (1:200).	261	293	- 1.20%	-0.21%
	'BRANCH-LINE', (1:150).	258	294	+49.01%	+0.59%
	'BRANCH-LINE', (1:200).	284	321	+39.04%	-0.55%
MALE.	'MAIN-LINE', (1:150).	38	102	- 6.83%	+2.22%
	'BRANCH-LINE', (1:150).	48	160	+23.17%	+1.17%
AVERAGE RESULT.		-	-	+20.68%	+0.79%

* - Most Representative Results.

FIGURE 10/111. - Comparative Assessment of Toilet/Tissue-Paper Content Between 'Faecal' and 'Non-Faecal' Flushes.

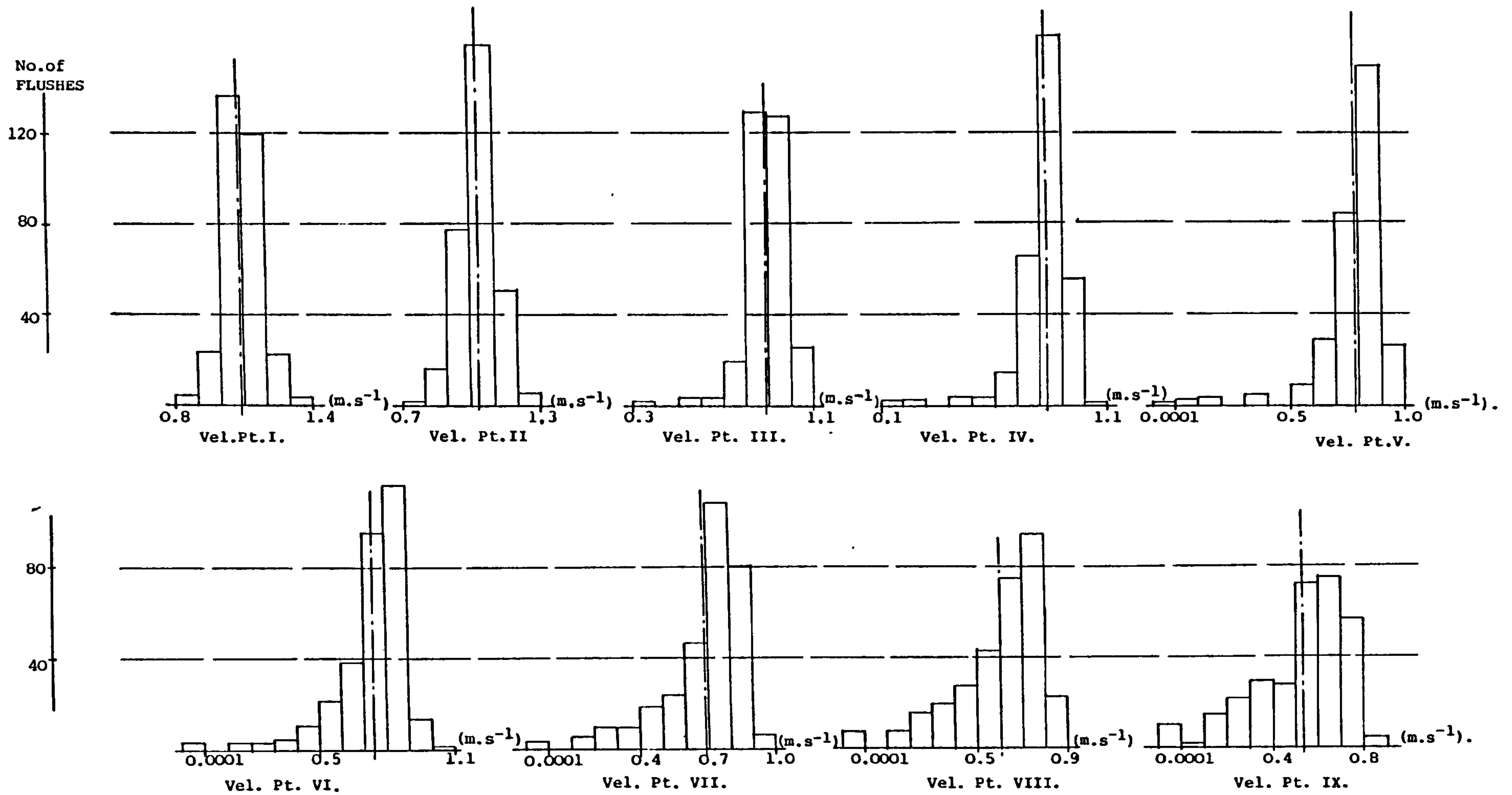
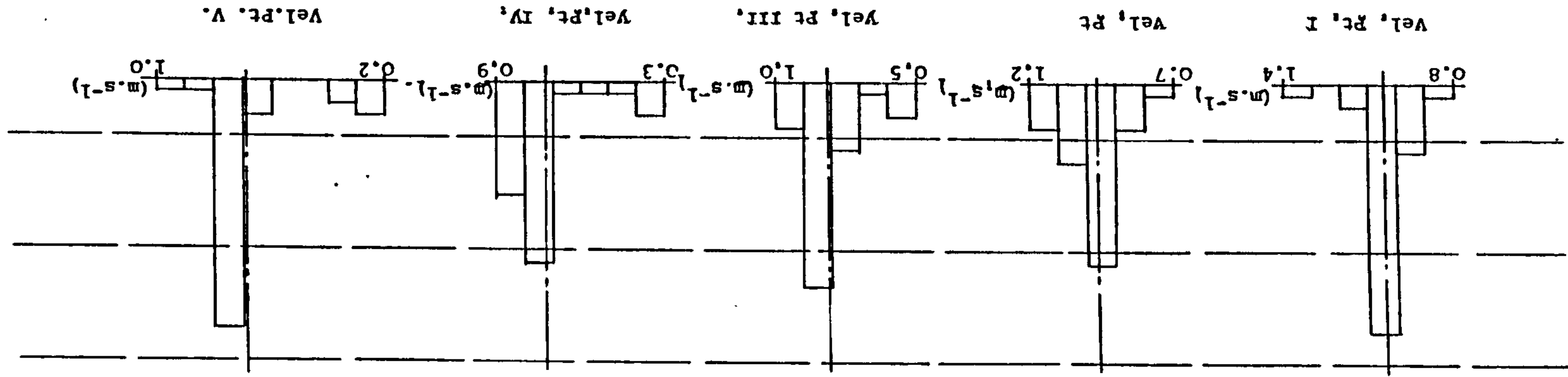
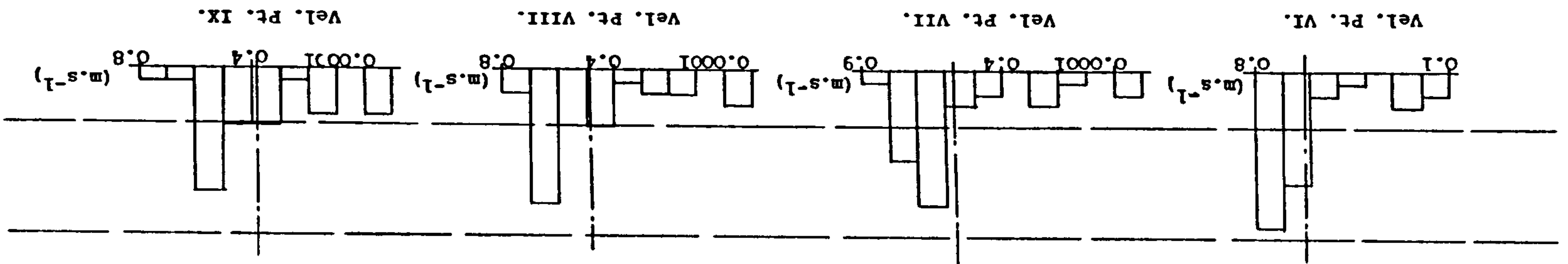

FIGURE 10/112. - DISTRIBUTION OF 'NON-FAECAL' FLUSH 'TRAILING SOLID' VELOCITIES, FOR EACH OF THE DIFFERENT VELOCITY MEASUREMENT POINTS, AS RECORDED, AT GRADIENT 1:150, AT THE FEMALE 'MAIN-LINE' INSTALLATION, (W.C.3).



5
15

5
15
25
No. of Flushes.

FIGURE 10/113. - DISTRIBUTION OF 'FARCAT' FLUSH 'TRAILING SOLID' VELOCITIES, FOR EACH OF THE DIFFERENT VELOCITY MEASUREMENT POINTS, AS RECORDED, AT GRADIENT 1:150, AT THE FEMALE 'MAIN-LINE' INSTALLATION, (M.C.3).

		$\sqrt{L/G}$										
		Vel. Pt. 1 (21.67)	Vel. Pt. 2 (24.89)	Vel. Pt. 3 (27.74)	Vel. Pt. 4 (30.32)	Vel. Pt. 5 (32.70)	Vel. Pt. 6 (34.92)	Vel. Pt. 7 (37.01)	Vel. Pt. 8 (38.98)	Vel. Pt. 9 (40.86)		
SAMPLE 1. (55 flushes).	\bar{x}	1.1047	1.0129	0.8394	0.7469	0.6898	0.6183	0.5677	0.4719	0.3987		
	S.D.	0.2227	0.2306	0.1869	0.2433	0.2941	0.2787	0.2833	0.2694	0.2727		
	Vd.	0.7384	0.6336	0.5319	0.3467	0.2060	0.1598	0.1017	0.0287	-		
	%	3.6	3.6	3.6	7.3	10.9	12.7	12.7	14.6	-		
SAMPLE 2. (307 flushes).	\bar{x}	1.0938	1.0290	0.8910	0.8274	0.7798	0.7413	0.6906	0.5984	0.5304		
	S.D.	0.0788	0.0767	0.0807	0.1102	0.1403	0.1588	0.1790	0.1908	0.1952		
	Vd.	0.9642	0.9028	0.7582	0.6461	0.5490	0.4801	0.3861	0.2845	0.2093		
	%	5.5	5.5	5.2	4.2	4.9	6.5	8.1	9.1	8.5		
SAMPLE 3. (5.1 + 5.2).	\bar{x}	1.0955	1.0266	0.8832	0.8152	0.7661	0.7226	0.6719	0.5792	0.5104		
	S.D.	0.1132	0.1145	0.1057	0.1419	0.1757	0.1875	0.2033	0.2097	0.2141		
	Vd.	0.9093	0.8382	0.7093	0.5818	0.4771	0.4142	0.3375	0.2342	0.1582		
	%	2.5	1.1	3.3	5.0	5.8	7.2	8.3	8.8	8.6		

L = Distance from input device to velocity measurement point.

G = Pipe gradient.

\bar{x} = Mean 'trailing' solid velocity (m.s⁻¹).

S.D. = Standard deviation of 'trailing solid' velocity (m.s⁻¹).

Vd. = That velocity which, assuming a 'normal' distribution, should have been exceeded by 95% of 'trailing solids', (m.s⁻¹).

% = Proportion of 'trailing solids' which did not exceed Vd, (%).

(where; Vd = $\bar{x} - 1.645$ (S.D.)).

FIGURE 10/114. - VARIATION, IN 'TRAILING SOLID' VELOCITY DISTRIBUTION, WITH DISTANCE FROM THE INPUT DEVICE, - (Female 'Main-Line' Installation, W.C.3, Gradient 1:150).

				K1.	K2.	N.
'FAECAL' FLUSHES.	MALE FACILITY	GRADIENT 1:150	W.C.5	2.762	2.598	64
			W.C.6	2.994	2.041	112
	FEMALE FACILITY	GRADIENT 1:150	W.C.3	3.070	2.345	55
			W.C.2	3.026	1.954	36
		GRADIENT 1:200	W.C.3	2.428	2.267	32
			W.C.2	2.748	2.471	37
'NON-FAECAL' FLUSHES.	MALE FACILITY	GRADIENT 1:150	W.C.5	3.816	2.672	38
			W.C.6	2.530	2.139	48
	FEMALE FACILITY	GRADIENT 1:150	W.C.3	1.957	1.768	307
			W.C.2	2.673	1.780	258
		GRADIENT 1:200	W.C.3	2.115	1.713	261
			W.C.2	3.049	1.879	284
'FAECAL' AND 'NON-FAECAL' FLUSHES.	MALE FACILITY	GRADIENT 1:150	W.C.5	3.008	2.839	102 (64 + 38)
			W.C.6	3.133	2.540	160 (112 + 48)
	FEMALE FACILITY	GRADIENT 1:150	W.C.3	2.384	1.715	362 (55 + 307)
			W.C.2	2.457	2.303	294 (36 + 258)
		GRADIENT 1:200	W.C.3	2.379	1.839	293 (32 + 261)
			W.C.2	3.061	2.641	321 (37 + 284)

Where; N = Sample size (no. of flushes). \bar{X} = Mean 'trailing solid' velocity (m.s⁻¹).

K1 = That value of 'K', whose associated values of 'Vd' were exceeded throughout by 95.00% of 'trailing solids'.

S.D. = Standard Deviation of 'trailing solid' velocity, (m.s⁻¹).

K = A constant.

K2 = That value of 'K', whose associated values of 'Vd' were exceeded throughout by 92.57% of 'trailing solids'.

Vd. = $\bar{X} - K.(S.D.)$, (design velocity, m.s⁻¹).

FIGURE 10/115. - OVERALL MEASURE OF 'TRAILING SOLID' VELOCITY DISTRIBUTION.

		SAMPLES CONTAINING BOTH 'FAECAL' AND 'NON-FAECAL' FLUSHES (IN VARYING PROPORTIONS).							
		MALE FACILITY				FEMALE FACILITY			
		GRADIENT 1:150		GRADIENT 1:150		GRADIENT 1:200		GRADIENT 1:200	
		W.C.5	W.C.6	W.C.3	W.C.2	W.C.3	W.C.2		
No. of 'Faecal' Flushes.	64	112	36	32	37				
No. of 'Non-Faecal' Flushes.	38	48	258	261	284				
Total Number of Flushes.	102	160	294	293	321				
K1 (A).	2.764	2.764	2.764	2.764	2.764	2.764	2.764	2.764	2.764
P1 (A).	92.2%	93.7%	97.0%	95.6%	93.8%	95.6%	93.8%	95.6%	93.8%
K2 (A).	2.136	2.136	2.136	2.136	2.136	2.136	2.136	2.136	2.136
P2 (A).	91.2%	90.0%	94.5%	92.2%	91.3%	94.9%	91.3%	94.9%	91.3%
K1 (B).	2.574	2.574	2.574	2.574	2.574	2.574	2.574	2.574	2.574
P1 (B).	92.2%	93.1%	95.6%	95.6%	92.2%	95.6%	92.2%	95.6%	92.2%
K2 (B).	1.923	1.923	1.923	1.923	1.923	1.923	1.923	1.923	1.923
P2 (B).	87.3%	87.5%	94.2%	92.2%	90.7%	93.2%	90.7%	93.2%	90.7%
K1 (C).	2.783	2.794	2.712	2.708	2.707	2.706	2.707	2.706	2.707
P1 (C).	92.2%	93.7%	96.7%	95.6%	93.5%	95.6%	93.5%	95.6%	93.5%
K2 (C).	2.172	2.193	2.036	2.027	2.025	2.023	2.025	2.023	2.025
P2 (C).	91.2%	90.6%	94.2%	92.2%	91.0%	94.5%	91.0%	94.5%	91.0%
K1 (D).	2.737	2.766	2.547	2.536	2.533	2.530	2.533	2.530	2.533
P1 (D).	92.2%	93.7%	95.6%	95.6%	91.9%	95.6%	91.9%	95.6%	91.9%
K2 (D).	2.097	2.129	1.894	1.881	1.878	1.876	1.878	1.876	1.878
P2 (D).	89.2%	90.0%	94.2%	92.2%	90.3%	92.8%	90.3%	92.8%	90.3%

	P1.			P2.	
	Mean.	Standard difference from 95.00%		Mean.	Standard difference from 92.57%
K1 (A).	94.65%	1.77%	K2 (A).	92.35%	1.97%
K1 (B).	94.05%	2.02%	K2 (B).	90.85%	3.47%
K1 (C).	94.55%	1.75%	K2 (C).	92.28%	1.72%
K1 (D).	94.10%	2.01%	K2 (D).	91.45%	2.28%

Where; 'K1 (A)', 'K1 (B)', 'K1 (C)' and 'K1 (D)' = Different Estimates of 'K1'.
 'K2 (A)', 'K2 (B)', 'K2 (C)' and 'K2 (D)' = Different Estimates of 'K2'.

'K1' = That value of 'K' (in the equation; $Vd = \bar{X} - K(S.D.)$), giving values of 'Vd' which, on average, would be exceeded throughout by 95% of 'trailing solids'.

'K2' = That value of 'K' (in the equation; $Vd = \bar{X} - K(S.D.)$), giving values of 'Vd' which, on average, would be exceeded throughout by 92.57% of 'trailing solids'.

'P1 (A)' = The proportion, of all 'trailing solids', which exceeded throughout that performance suggested by $K = K1 (A)$, ('P1 (B)', 'P1 (C)' and 'P1 (D)', being similarly associated with 'K1 (B)', 'K1 (C)' and 'K1 (D)' respectively).

'P2 (A)' = The proportion, of all 'trailing solids', which exceeded throughout that performance suggested by $K = K2 (A)$, ('P2 (B)', 'P2 (C)' and 'P2 (D)', being similarly associated with 'K2 (B)', 'K2 (C)' and 'K2 (D)' respectively).

\bar{X} = Mean 'trailing solid' velocity, (m.s⁻¹).

S.D. = Standard deviation of 'trailing solid' velocity, (m.s⁻¹).

Vd = Design velocity, to be exceeded by a set majority of 'trailing solids' as associated with a particular value of 'K', (m.s⁻¹).

K = A constant, (in the equation; $Vd = \bar{X} - K(S.D.)$).

FIGURE 10/116. - ASSESSMENT OF COMBINED SAMPLE VELOCITY DISTRIBUTION.

VELOCITY MEASUREMENT POINT.	$\sqrt{L/G}$ (m.)	FEMALE 'MAIN-LINE' INSTALLATION, (W.C.3), GRADIENT 1:150.					
		'FAECAL FLUSH' SAMPLE (55 FLUSHES).		'NON-FAECAL FLUSH' SAMPLE. (307 FLUSHES)		'COMBINED' SAMPLE (55 + 307 = 362 FLUSHES)	
		\bar{X}	S.D.	\bar{X}	S.D.	\bar{X}	S.D.
1	21.67	1.1047	0.2227	1.0938	0.0788	1.0955	0.1132
2	24.89	1.0129	0.2306	1.0290	0.0767	1.0266	0.1145
3	27.74	0.8394	0.1869	0.8910	0.0807	0.8832	0.1057
4	30.32	0.7469	0.2433	0.8274	0.1102	0.8152	0.1419
5	32.70	0.6898	0.2941	0.7798	0.1403	0.7661	0.1757
6	34.92	0.6183	0.2787	0.7413	0.1588	0.7226	0.1875
7	37.01	0.5677	0.2833	0.6906	0.1790	0.6719	0.2033
8	38.98	0.4719	0.2694	0.5984	0.1908	0.5792	0.2097
9	40.86	0.3987	0.2727	0.5304	0.1952	0.5104	0.2141

\bar{X} = Mean 'trailing solid' velocity, (m.s⁻¹).
 L = Distance from 'input device', (m.).

Based upon only those 'single' flushes which were successfully monitored, and which encountered no previous deposits already in the system. 'Branch-line' values of ' $\sqrt{L/G}$ ' have been adjusted to account for an approximate gradient of 1:58 over that 1.428 metres between the input device (W.C.2), and its associated 135° junction.

VELOCITY MEASUREMENT POINT.	$\sqrt{L/G}$ (m.)	FEMALE 'BRANCH-LINE' INSTALLATION, (W.C.2), GRADIENT 1:150.					
		'FAECAL FLUSH' SAMPLE (36 FLUSHES).		'NON-FAECAL FLUSH' SAMPLE (258 FLUSHES).		'COMBINED' SAMPLE (36 + 258 = 294 FLUSHES).	
		\bar{X}	S.D.	\bar{X}	S.D.	\bar{X}	S.D.
1	20.11	0.8625	0.1141	0.9130	0.0927	0.9068	0.0970
2	23.55	0.8539	0.1248	0.9128	0.1335	0.9056	0.1338
3	26.54	0.7518	0.1571	0.7916	0.1394	0.7868	0.1423
4	29.23	0.6578	0.1851	0.7302	0.1606	0.7214	0.1656
5	31.69	0.5936	0.1824	0.6820	0.1751	0.6712	0.1784
6	33.98	0.5421	0.1940	0.6541	0.1857	0.6404	0.1903
7	36.12	0.4450	0.2282	0.6079	0.1933	0.5880	0.2050
8	38.14	0.3545	0.1964	0.5331	0.1976	0.5112	0.2060
9	40.06	0.3017	0.2003	0.4857	0.1926	0.4632	0.2028

S.D. = Standard deviation of 'trailing solid' velocity, (m.s⁻¹).
 G = Pipe gradient.

FIGURE 10/117. - BASIC SOLID VELOCITY DATA, AS RECORDED, AT GRADIENT 1:150, AT THE FEMALE 'ON-SITE' INSTALLATION.

VELOCITY MEASUREMENT POINT	$\sqrt{L/G}$, (m)	FEMALE 'MAIN-LINE' INSTALLATION, (W.C. 3), GRADIENT 1:200.					
		'FAECAL FLUSH' SAMPLE. (32 FLUSHES).		'NON-FAECAL FLUSH' SAMPLE (261 FLUSHES).		'COMBINED' SAMPLE (32 + 261 = 293 FLUSHES).	
		\bar{X}	S.D.	\bar{X}	S.D.	\bar{X}	S.D.
1	25.02	1.0350	0.0726	1.0318	0.0736	1.0321	0.0735
2	28.74	0.9634	0.0827	0.9959	0.0712	0.9923	0.732
3	32.03	0.8009	0.0999	0.8484	0.0826	0.8432	0.0859
4	35.01	0.7260	0.1425	0.7754	0.1009	0.7700	0.1074
5	37.76	0.6853	0.1858	0.7516	0.1342	0.7443	0.1423
6	40.32	0.6153	0.1887	0.6977	0.1537	0.6887	0.1600
7	42.73	0.5675	0.2231	0.6563	0.1715	0.6466	0.1801
8	45.01	0.4815	0.2154	0.5956	0.1730	0.5831	0.1816
9	47.18	0.3823	0.2019	0.5194	0.1730	0.5044	0.1815

\bar{X} = Mean 'trailing solid' velocity, (m.s⁻¹).

L = Distance from 'input device', (m).

Based upon only those 'single' flushes which were successfully monitored, and which encountered no previous deposits already in the system. 'Branch-line values of ' $\sqrt{L/G}$ ' have been adjusted to account for an approximate gradient, of 1:62, over that 1.428 metres between the input device (W.C.2), and its associated 135° junction.

VELOCITY MEASUREMENT POINT	$\sqrt{L/G}$, (m)	FEMALE 'BRANCH-LINE' INSTALLATION, (W.C.2), GRADIENT 1:200.					
		'FAECAL FLUSH' SAMPLE. (37 FLUSHES).		'NON-FAECAL FLUSH' SAMPLE (284 FLUSHES).		'COMBINED' SAMPLE. (37 + 284 = 321 FLUSHES)	
		\bar{X}	S.D.	\bar{X}	S.D.	\bar{X}	S.D.
1	22.75	0.8197	0.2011	0.8725	0.1055	0.8664	0.1216
2	26.78	0.7597	0.1891	0.8731	0.0933	0.8600	0.1146
3	30.29	0.5782	0.2525	0.7348	0.1143	0.7168	0.1463
4	33.43	0.4499	0.2853	0.6498	0.1521	0.6267	0.1842
5	36.30	0.3527	0.2688	0.5907	0.1848	0.5633	0.2105
6	38.95	0.2936	0.2449	0.5189	0.1951	0.4929	0.2139
7	41.44	0.1952	0.2128	0.4478	0.2098	0.4187	0.2251
8	43.79	0.1531	0.1812	0.3736	0.1967	0.3482	0.2073
9	46.02	0.1170	0.1595	0.3113	0.1766	0.2889	0.1854

S.D. = Standard deviation of 'trailing solid' velocity, (m.s⁻¹).

G = Pipe gradient.

FIGURE 10/118. - BASIC SOLID VELOCITY DATA, AS RECORDED, AT GRADIENT 1:200, AT THE FEMALE 'ON-SITE' INSTALLATION.

Bend Position, - $\sqrt{L/G} = 34.62$

VELOCITY MEASUREMENT POINT	$\sqrt{L/G}, (m.s^{-1})$	MALE 'MAIN-LINE' INSTALLATION, (W.C.5), GRADIENT 1:150.					
		'FAECAL FLUSH' SAMPLE (64 FLUSHES).		'NON-FAECAL FLUSH' SAMPLE (38 FLUSHES).		'COMBINED' SAMPLE (64 + 38 = 102 FLUSHES).	
		\bar{x}	S.D.	\bar{x}	S.D.	\bar{x}	S.D.
1	18.23	1.3504	0.2092	1.3817	0.1641	1.3620	0.1942
2	21.96	1.1653	0.2068	1.1906	0.1178	1.1747	0.1793
3	25.14	1.0216	0.1811	1.0357	0.1029	1.0269	0.1567
4	27.97	0.8766	0.2118	0.8684	0.2224	0.8735	0.2158
5	30.53	0.7428	0.2856	0.7854	0.2169	0.7587	0.2629
6	32.90	0.6352	0.2995	0.7489	0.2379	0.6776	0.2835

\bar{x} = Mean trailing solid velocity, (m.s⁻¹).

L = Distance from 'input device', (m).

Based upon only those 'single' flushes which were successfully monitored, and which encountered no previous deposits already in the system. 'Branch-line' values of ' $\sqrt{L/G}$ ' have been adjusted to account for an approximate gradient, of 1:69, over that 1.265 metres between the input device (W.C.6), and its associated 135° junction.

Bend position, - $\sqrt{L/G} = 34.10$

VELOCITY MEASUREMENT POINT	$\sqrt{L/G}, (m.s^{-1})$	MALE 'BRANCH-LINE' INSTALLATION, (W.C.6), GRADIENT 1:150.					
		'FAECAL FLUSH' SAMPLE (112 FLUSHES).		'NON-FAECAL FLUSH' SAMPLE (48 FLUSHES).		'COMBINED' SAMPLE (112 + 48 = 160 FLUSHES).	
		\bar{x}	S.D.	\bar{x}	S.D.	\bar{x}	S.D.
1	17.23	0.8680	0.2022	0.8955	0.1480	0.8763	0.1880
2	21.14	0.7412	0.2075	0.8144	0.1978	0.7632	0.2073
3	24.43	0.6774	0.2574	0.0811	0.2082	0.7145	0.2502
4	27.33	0.5781	0.2833	0.7178	0.2098	0.6200	0.2711
5	29.95	0.4930	0.2866	0.6465	0.2145	0.5391	0.2761
6	32.35	0.4163	0.2693	0.5883	0.2428	0.4679	0.2732

S.D. = Standard deviation of 'trailing solid' velocity, (m.s⁻¹).

G = Pipe gradient.

FIGURE 10/119. - BASIC SOLID VELOCITY DATA, AS RECORDED, AT GRADIENT 1:150, AT THE MALE 'ON-SITE' INSTALLATION.

VELOCITY POINT NUMBER.	1	2	3	4	5	6	7	8	9
$\sqrt{L/G}$, (m ^{1/2}).	21.67	24.89	27.74	30.32	32.70	34.92	37.01	38.98	40.86
MALE FACILITY	\bar{X}_p	1.0171	0.8530	0.7681	0.7135	0.6507	0.6001	0.5052	0.4334
DESIGN METHOD.	S.D.p	0.2019	0.1672	0.2192	0.2655	0.2584	0.2655	0.2572	0.2611
	Vd	0.4520	0.3850	0.1546	-	-	-	-	-
FEMALE FACILITY	\bar{X}_p	1.0268	0.8841	0.8166	0.7678	0.7249	0.6742	0.5815	0.5128
DESIGN METHOD.	S.D.p	0.1106	0.1031	0.1385	0.1719	0.1843	0.2006	0.2076	0.2120
	Vd	0.8023	0.6748	0.5354	0.4188	0.3508	0.2670	0.1601	0.0824

\bar{X}_p = Predicted mean 'trailing solid' velocity (m.s⁻¹), for a 'normal' male/female facility.
 S.D.p = Predicted standard deviation of 'trailing solid' velocity (m.s⁻¹), for a 'normal' male/female facility.
 Vd = Design velocity, (m.s⁻¹), for a 'normal' male/female facility.
 (Vd = \bar{X}_p - 2.799 (S.D.p), for the male design, or Vd = \bar{X}_p - 2.030 (S.D.p), for the female design).

FIGURE 10/120 - Estimated Design Velocity Data, - constructed from female 1:150 'waste load' data, and applicable for female 'main-line' installation (W.C.3), 'system geometry'.

VELOCITY POINT NUMBER.	1	2	3	4	5	6	
$\sqrt{L/G}$, (m ^{1/2}).	18.23	21.96	25.14	27.97	30.53	32.90	
MALE FACILITY DESIGN METHOD.	\bar{x}_p	1.3586	1.1720	1.0253	0.8744	0.7540	0.6651
	S.D.p	0.1988	0.1878	0.1643	0.2147	0.2699	0.2889
	v_d	0.8022	0.6463	0.5654	0.2735	-	-

\bar{x}_p = Predicted mean 'trailing solid' velocity, (m.s⁻¹), for a 'normal' male facility.

S.D.p = Predicted standard deviation of 'trailing solid' velocity, (m.s⁻¹), for a 'normal' male facility.

v_d = Design velocity, (m.s⁻¹), for a 'normal' male facility = $\bar{x}_p - 2.799$ (S.D.p).

FIGURE 10/121. - Estimated Design Velocity Data, - constructed from male 1:150 'waste load' data, and applicable for male 'main-line' installation (W.C.5), 'system geometry'.

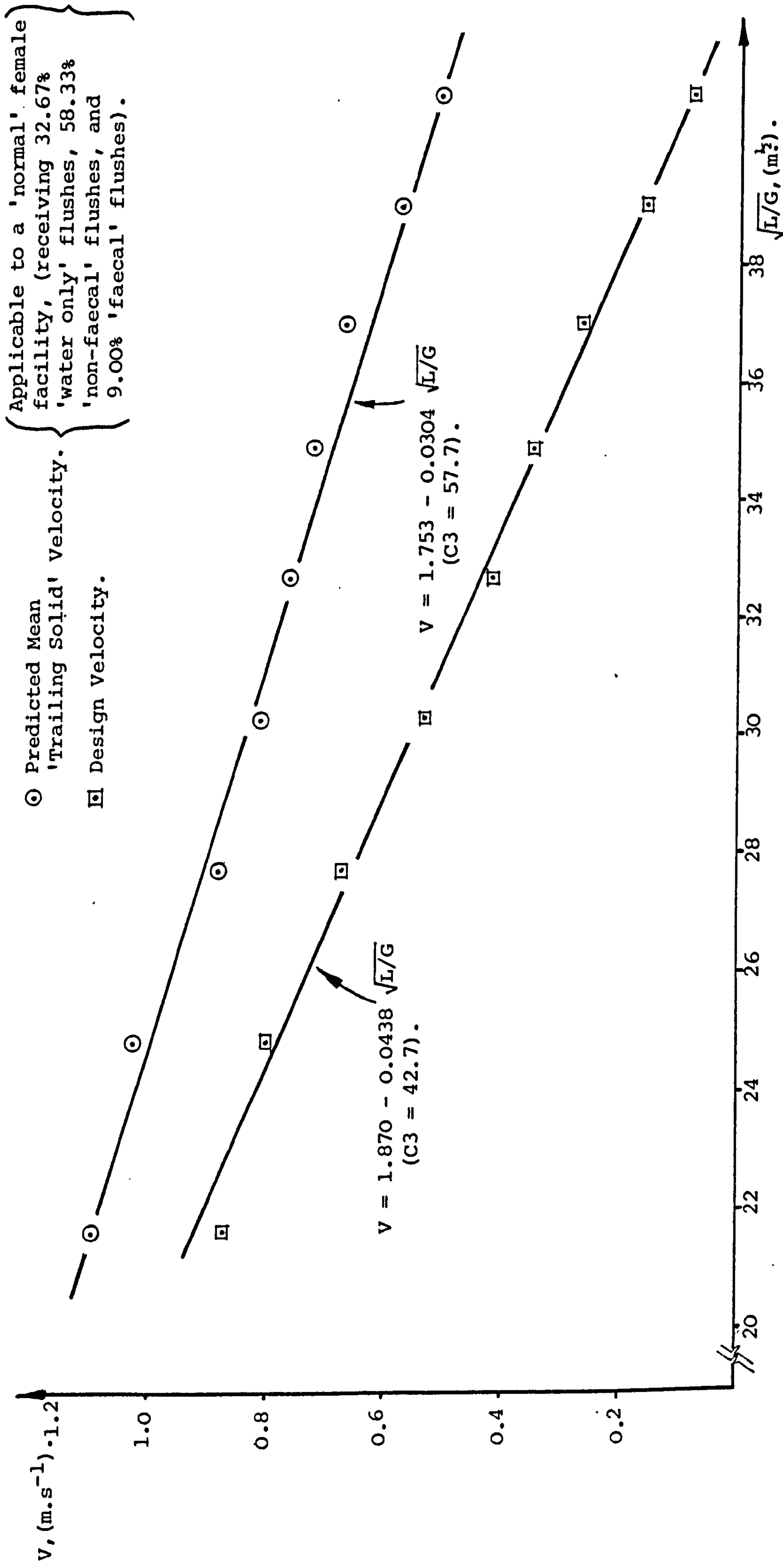

Applicable to a 'normal' female facility, (receiving 32.67% 'water only' flushes, 58.33% 'non-faecal' flushes, and 9.00% 'faecal' flushes).

FIGURE 10/122. - Female Facility Design Performance Level, - constructed from female 'waste load' data, and applicable for female 'main-line' installation (W.C.3), 'system geometry' .

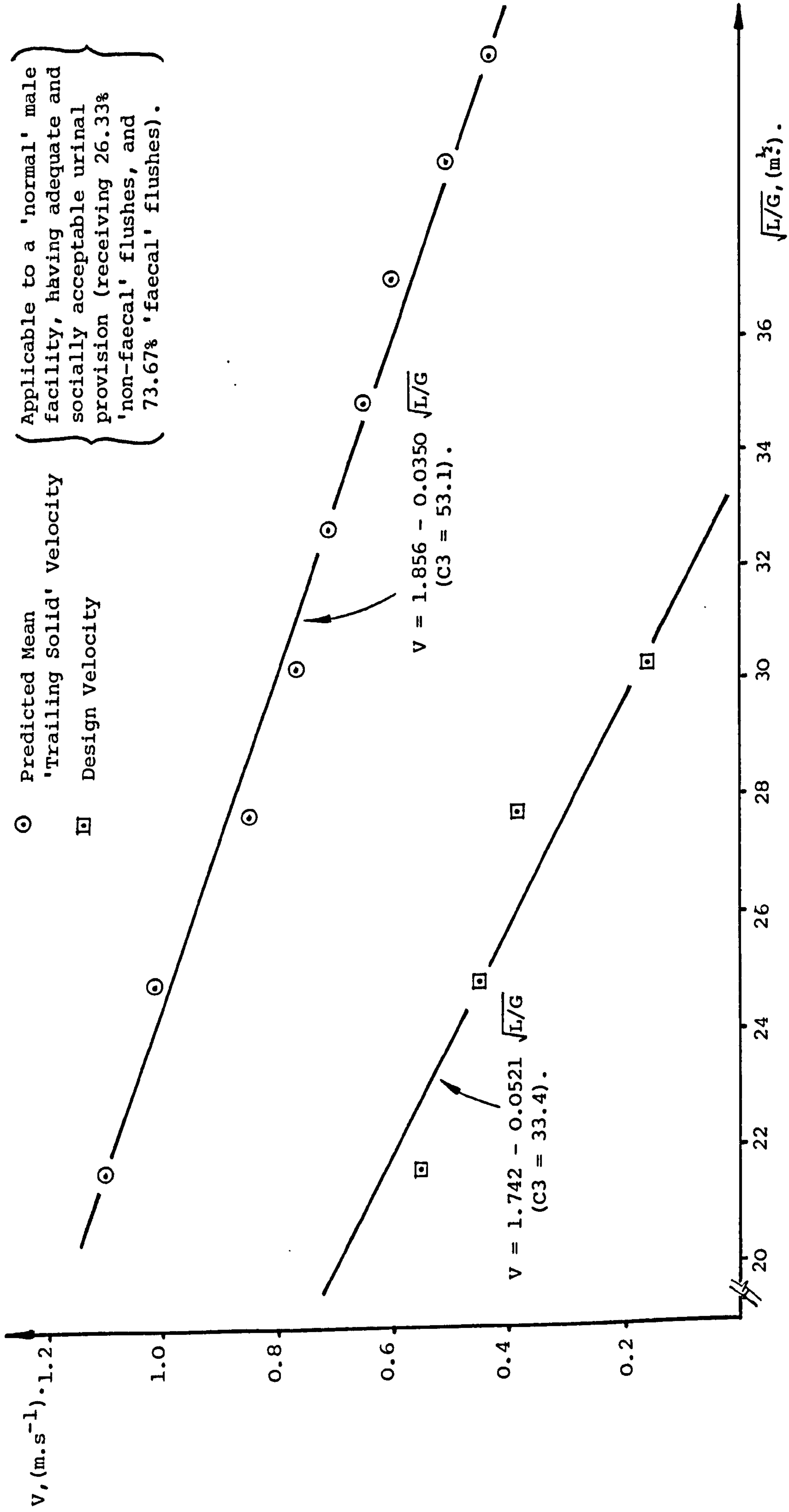

FIGURE 10/123. - Male Facility Design Performance Level, - constructed from female 'waste load' data, and applicable for female 'main-line' installation (W.C.3), 'system geometry'.

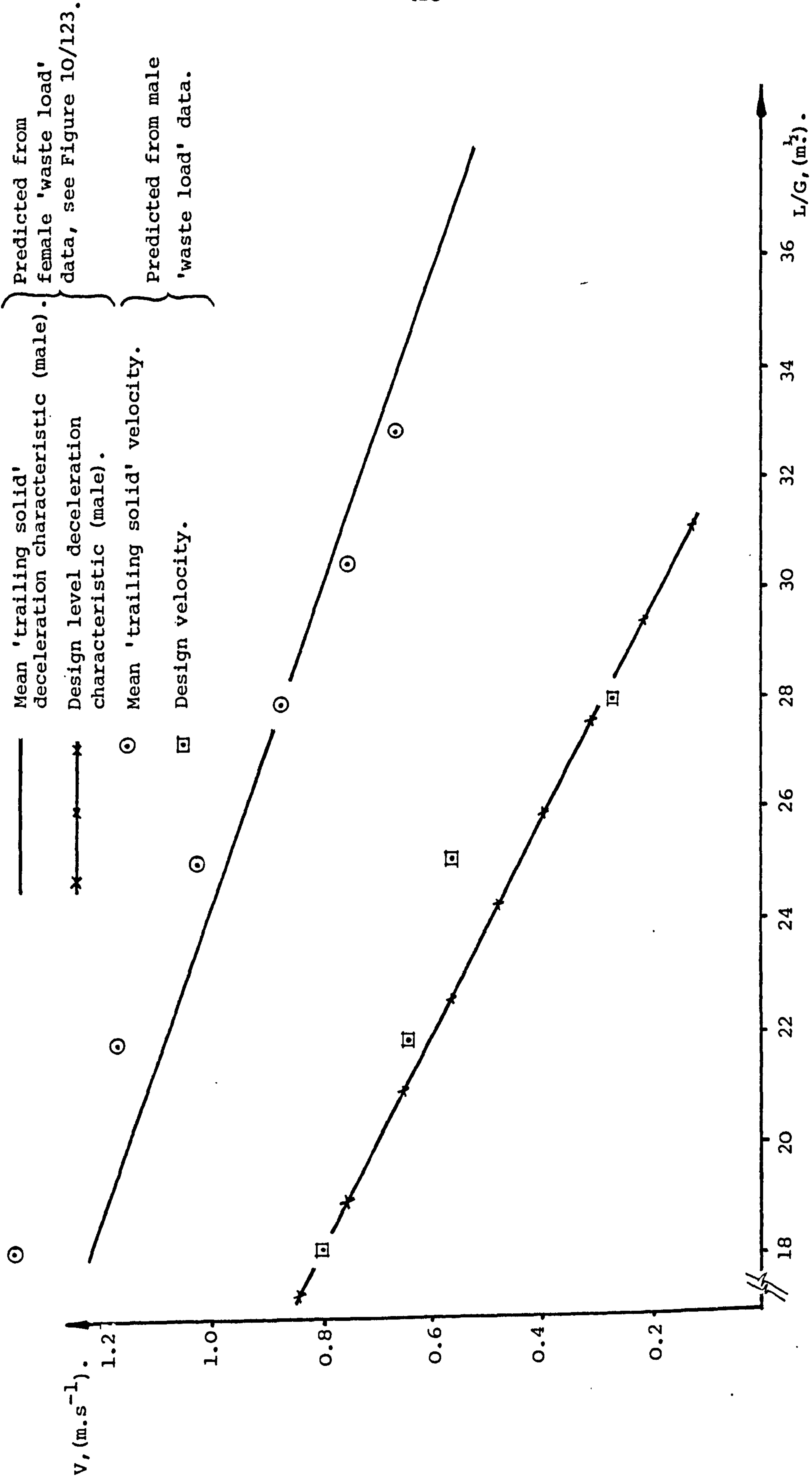

FIGURE 10/124. - Check of Male Facility Design Performance Level, - constructed from male 'waste load data, and applicable for male 'main-line' installation (W.C.5), 'system geometry'.

APPENDIX I

A1. MASTER DREG COMPUTER PROGRAM.

A1 - 1 Listing of Variable Names.

LABL	-	indicates the type of data to be read into the program.
LABL 1	-	indicates alphanumeric data (headings etc.).
LABL 2	-	indicates data which remains constant for any one particular set up of the rig.
LABL 3	-	indicates data which must be recorded for each flush of the W.C.
LABL 4	-	indicates that a complete new set of data is to be fed in, followed by a complete re-run of the program. After LABL 4 new type 1, 2 and 3, data is fed in.
N	=	the number of sets of photocells.
NS	=	the number of successful flushes.
NT	=	the number of cases where the solid stops in the pipe.
NF	=	the number of W.C. failures.
NR	=	the number of flushes (number of runs).
RN	=	the run number (e.g. 250.030).
RUN(NS)	=	values of RN for successful flushes only.
SP(N)	=	the separation between a set of photocells (M).
POS(N)	=	distance of velocity measuring point from W.C. (M).
X	=	the L.V.D.T. deflection synonymous to volumes ahead of solid.
DMAX	=	the maximum L.V.D.T. deflection (for 9.1 litres).
IY(N)	=	timer counter readings (secs x 10^{-4}) as integer numbers.
TIME(N)	=	values of IY(N) in seconds and as real numbers.
PFAS(NS)	=	percentage of flush ahead of solid measured at collection tank.
VASL(NS)	=	volume ahead of the solid in litres measured at tank.

STPS = Distance of stoppage position from W.C. (metres).
STPOS (NS) = Values of STPS stored in array for all successful flushes.
STP (NT) = Values of STPS stored in array only where solid
stopped, i.e. no zero values.

PFASD = Standard deviation of values of PFAS(NS).
PFAMN = Minimum value of values of PFAS(NS).
PFAMX = Maximum value of values of PFAS(NS).
PFAM = Mean of values of PFAS(NS).

VASSD = Standard deviation of values of VASL(NS).
VASMN = Minimum value of VASL(NS)
VASMX = Maximum value of VASL(NS)
VASM = Mean of values of VASL(NS)

STPSD = Standard deviation of values of STP(NT)
STPMN = Minimum value of STP(NT)
STPMX = Maximum value of STP(NT)
STPM = Mean of values of STP(NT)

VEL(N,NS) = Values of velocity measured at each velocity point
for all successful runs stored in array.

VLCTY (NS) = Values of velocity for all successful runs
measured at one velocity point only.

VLCM = Mean of values of VLCTY(NS)
VLCMX = Maximum value of VLCTY(NS)
VLCMN = Minimum value of VLCTY(NS)
VLCSD = Standard deviation of values of VLCTY(NS)

VELM(N) = Values of VLCM stored in array.
VELMX(N) = Values of VLCMX stored in array.
VELMN(N) = Values of VLCMN stored in array.
VELSD(N) = Values of VLCSD stored in array.

NTOTAL(N) = Number of velocities in particular interval for one
velocity point.

V1 = Lower limit of histogram interval.
V2 = Upper limit of histogram interval.

A1 - 2 Data Controls.

If a value of IY equal to zero is fed into the program, this is taken to mean velocity is equal to zero and NOT infinite velocity.

If a value of STPS equal to zero is fed into the program, this is taken to mean that there is no stoppage position as the solid cleared the pipe.

If a value of x equal to DMAX is fed into the program, the program recognises this as a W.C. failure.

If a value of x greater than DMAX is fed into the program, this is taken to indicate an end of LABL 3 data, and the program will not compute if further LABL 3 data has been entered.

At the end of the program , if a further complete new set of data is NOT available for analysis, insertion of any value of LABL, other than 4, will cause the program to terminate. For convenience, and to save confusion, a value of LABL equal to zero was used for this purpose.

A1 - 3 Flow Diagram (Master DREG).

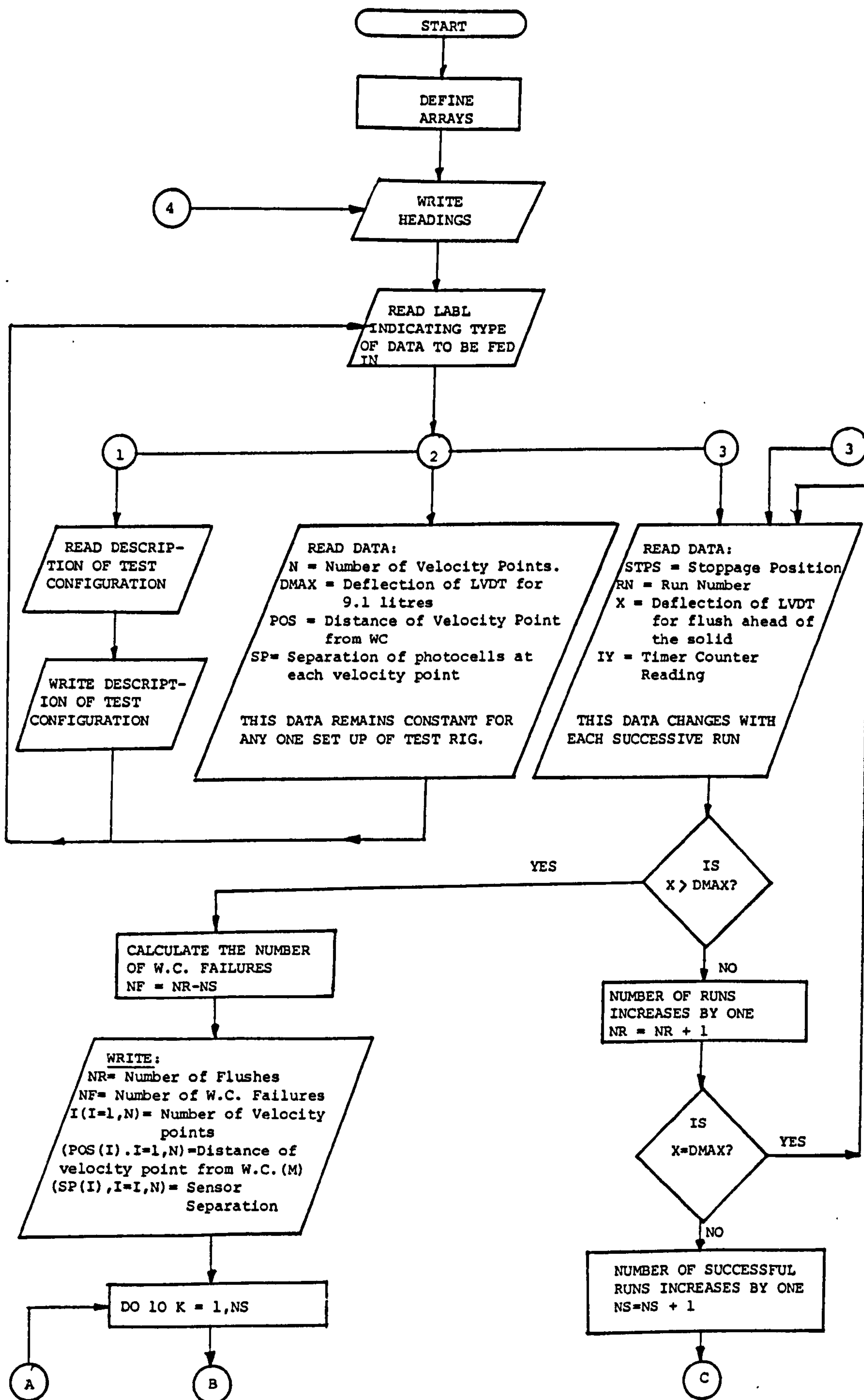

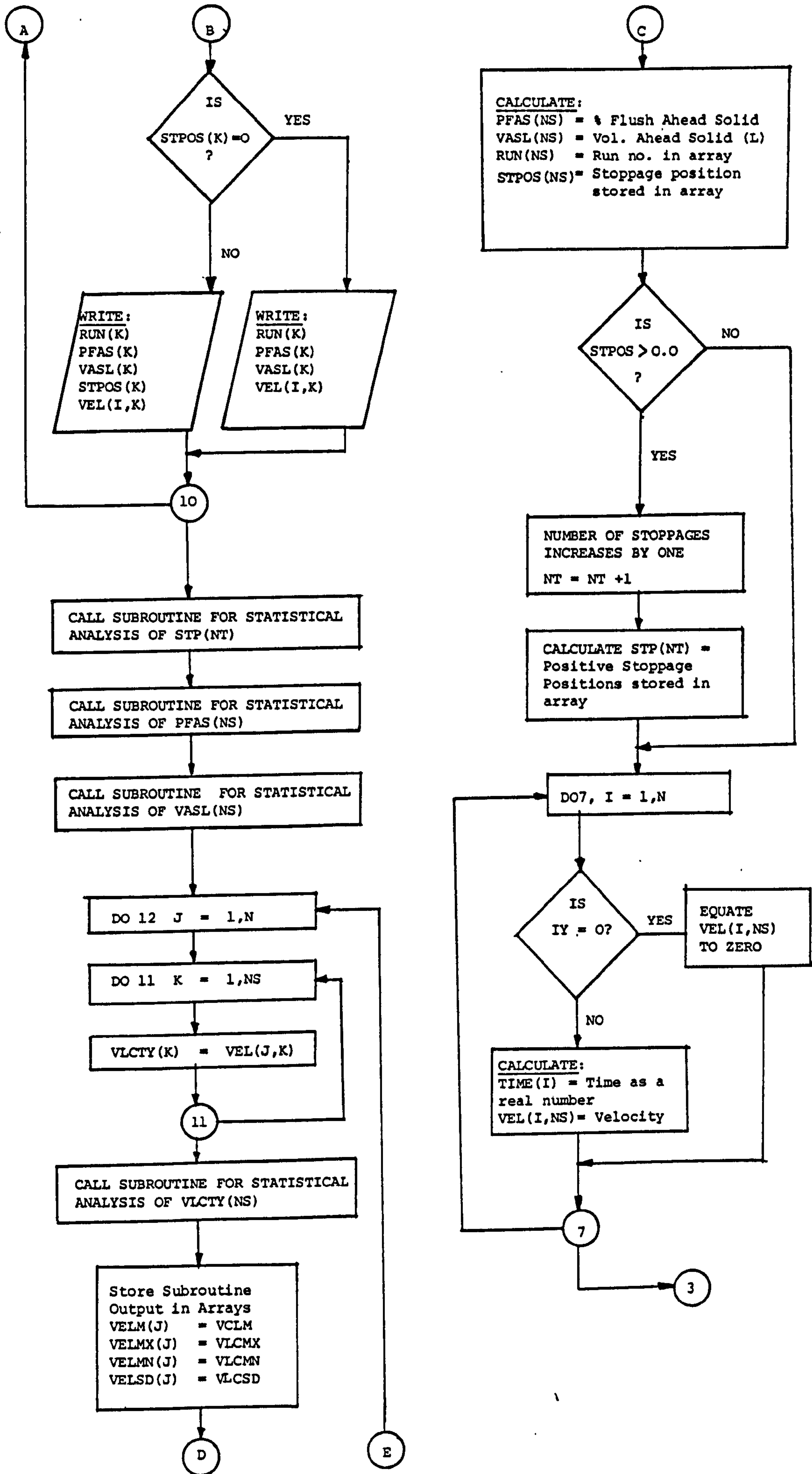

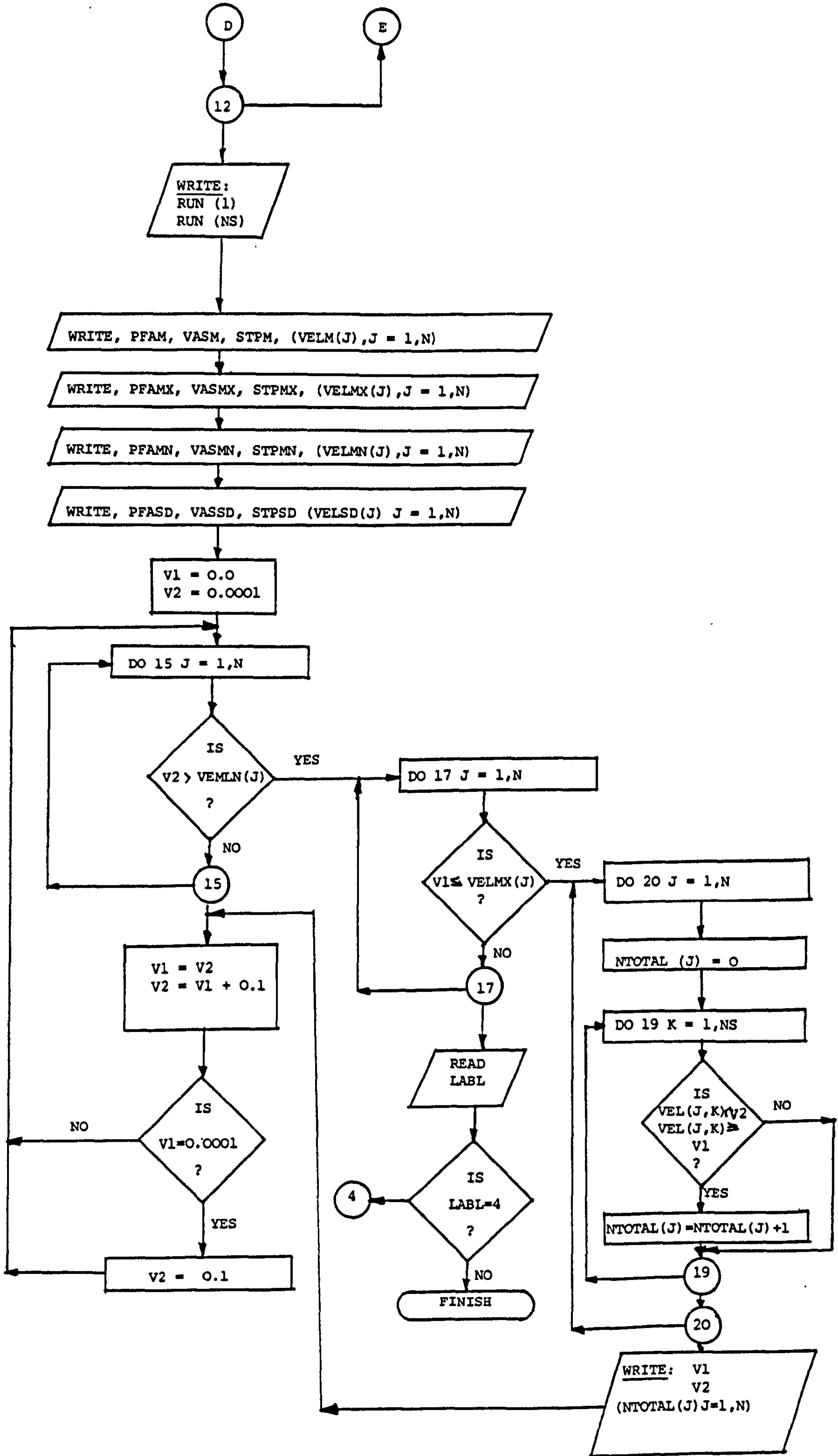

A1 - 4 Flow Diagram (Subroutine STATIS).

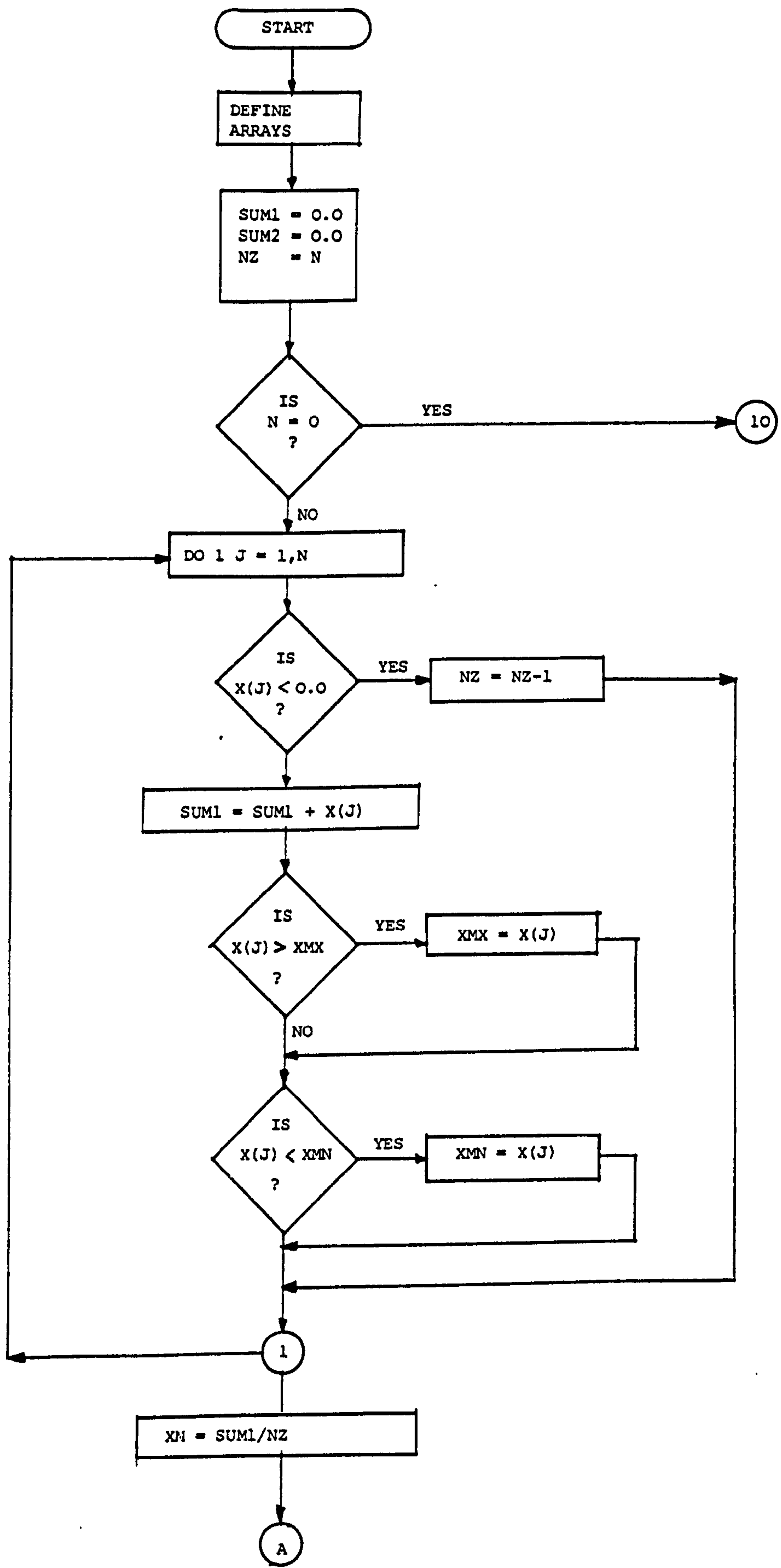

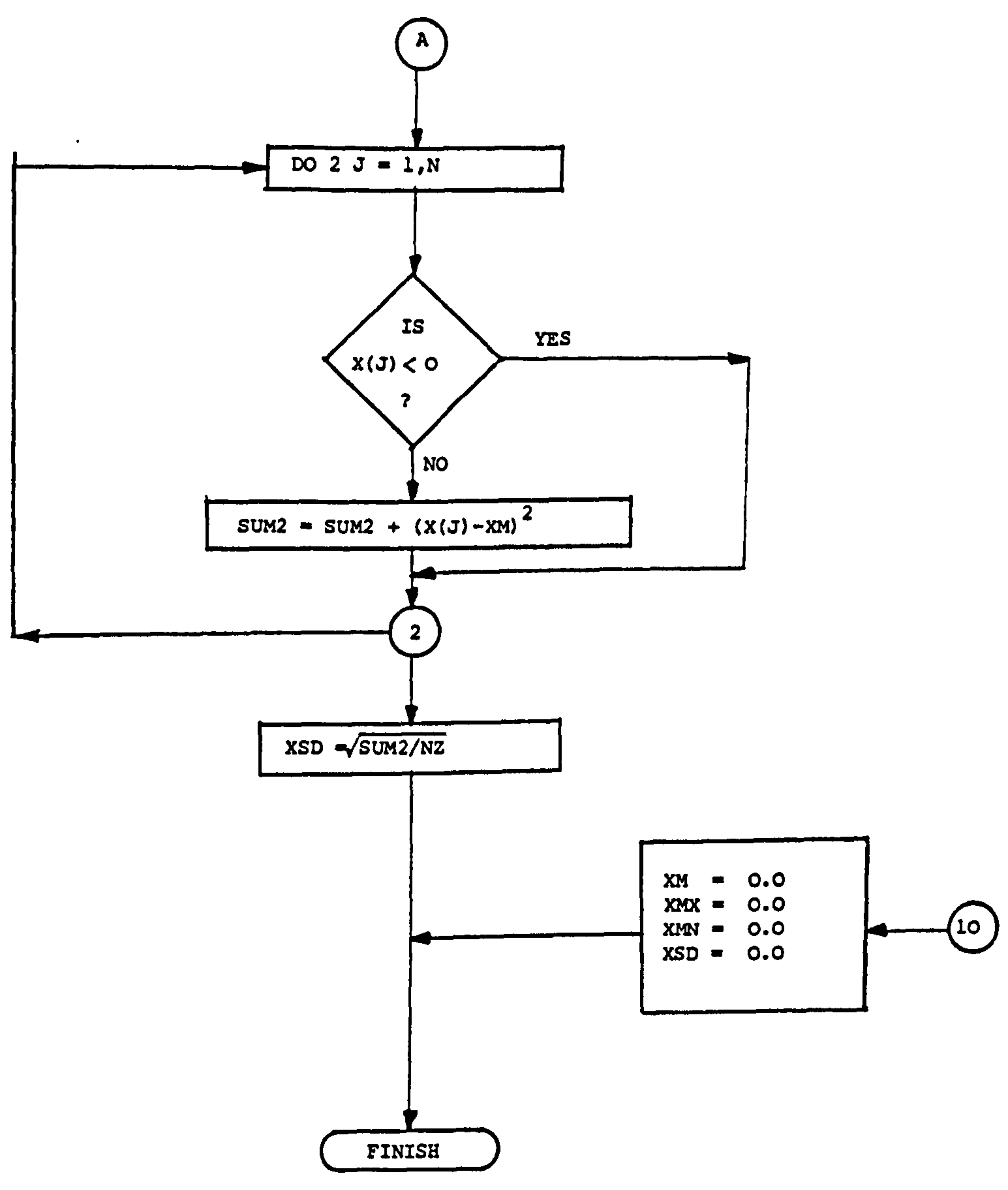

Al - 5 Program Listing.

#LISTING OF IDT.SD=WCSDDB(1/B1B0) PRODUCED ON 7AUG78 AT 19.43.16
#OUTPUT BY LISTFILE III IDT.SD=WCSDDB1 ON 7AUG78 AT 19.44.01 USING 3
DOCUMENT IDT.SD=WCSDDB(/B1B0)

STARTED IDT.SD=WCSDDB, 7AUG78 , 19.01.43 TYPETRACK
19.01.44* JOB SD=WCSDDB,IBT
19.01.45* SD=WCSDDB
19.01.45* BFORTRAN SD=SOURCE,SD=DATA,CLIST
19.01.46* TA AB,GN
WAITING FOR JOB TO BE FULLY STARTED
19.38.53 JOB IS NOW FULLY STARTED
19.39.30 0.03 CORE GIVEN 32576
0.12 ;HALTED ; EP
0.16 ;HALTED ; BP
19.41.23 FREE *DA3 ,13 TRANSFERS
19.41.26 FREE *CR0 ,173 TRANSFERS
19.41.26 FREE *DA1 ,11 TRANSFERS
19.41.26 FREE *DA4 ,10 TRANSFERS
0.26 ;DELETED ; FI
19.41.27 FREE *DA0 ,249 TRANSFERS
19.41.27 FREE *LPG ,201 TRANSFERS
19.41.27 0.26 DELETED,CLOCKED 0.10

FORTAN COMPILATION BY #XFIV IIK 3N DATE 07/08/78 TIME 10/39/39

0000 PROGRAM (WCSDDB)
0001 INPUT 5PCRO
0002 OUTPUT 6=LPG
0003 TRACE 2
0004 END

0005 MASTER DREG
0006 DIMENSION E(9),POS(4),SP(6),IY(6),PFAS(100),VASL(100),
0007 :RUN(100),STPOS(100),TIMR(6),VEL(6,100),STP(100),VLCTY(100),
0008 2VELU(6),VELUX(6),VELMN(4),VELSD(6),ITOTAL(6)
0009 WRITE (6,200)
0010 FORMAT (1H1,///,20X,
0011 158H HOSPITAL DRAINAGE DESIGN = DECELERATION CHARACTERISTICS.//,
0012 220X,58HDR,J.A.SUAFFIELD AND S.D.BOKOR, = DRAINAGE RESEARCH GROUP,;
0013 3/,20X,58H DEPARTMENT OF BUILDING TECHNOLOGY, = BRUNEL UNIVERSITY
0014 4,///)
0015 NRM0
0016 NSM0
0017 NTM0
0018 READ (5,100) LABEL
0019 GO TO (1,2,3),LABEL
0020 READ (5,101) (E(I),I=1,05
0021 FOKIAT (9A8)
0022 WRITE (6,201) (E(I),I=1,9)

```

0023 FORMAT (2UX,9A8)
0024 FORMAT (I0)
0025 GO TO 6
0026 READ (5,102) N,DMAX,(POS(I),I=1,N),(SP(I),I=1,N)
0027 FORMAT (I0,13F0.0)
0028 GO TO 6
0029 READ (5,103) RN,X,STPS,(Y(I),I=1,N)
0030 FORMAT (3F0.0,6I0)
0031 IF (X.GT.DMAX) GO TO 5
0032 NR=NR+1
0033 IF (X.EQ.DMAX) GO TO 3
0034 IF (DMAX.GT.X) NS=NS+1
0035 PFAS(NS)=(X/DMAX)*100.0
0036 VASL(NS)=(X/DMAX)*9.1
0037 RUN(NS)=RN
0038 STPOS(NS)=STPS
0039 IF (STPOS(NS).GT.0.0) NY=NY+1
0040 IF (STPOS(NS).GT.0.0) STP(:IT)=STPOS(NS)
0041 DO 7 I=1,N
0042 IF (Y(I).EQ.0) GO TO 600
0043 TIME(I)=FLOAT(Y(I))/(10.0**4)
0044 VEL(I,NS)=SP(I)/TIME(I)
0045 GO TO 650
0046 VEL(I,NS)=0.0
0047 CONTINUE
0048 CONTINUE
0049 GO TO 3
0050 NF=NR*NS
0051 WRITE (6,202) NR,NF
0052 FORMAT (/20X,20HNUMBER OF FLUSHES = ,I4,15X,
0053 126HNUMBER OF U.C. FAILURES = ,I4,/)
0054 IF (NF.EQ.NR) GO TO 21
0055 WRITE (6,203) (I,I=1,N)
0056 FORMAT (28X,22HPHOTOCELL SET NUMBER.,15X,6(I5,3X))
0057 WRITE (6,204) (POS(I),I=1,N)
0058 FORMAT (28X,22HDISTANCE (M) FROM U.C.,14X,6F8.3)
0059 WRITE (6,205) (SP(I),I=1,N)
0060 FORMAT (28X,22HSENSOR SEPERATION (I),14X,6F8.1)
0061 WRITE (6,206)
0062 FORMAT (/17X,7HRUN NO.,1X,11HFLUSH AHEAD,4X,11HFLUSH AHEAD,5X,
0063 114HDIST. TO STOP,20X,14HVELOCITY, 11/S.)
0064 WRITE (6,207)
0065 FORMAT (16X,10HSOLID (X),5X,10HSOLID (L),5X,14HFROM U.C. (M).)
0066 DO 10 K=1,NS
0067 IF (STPOS (K).EQ.0.0) GO TO 8
0068 WRITE (6,208) RUN(K),PFAR(K),VASL(K),STPOS(K),(VEL (I,K),I=1,N)
0069 FORMAT (7X,F7.3,5X,F6.3,9X,F5.3,13X,F5.2,9X,6(F6.4,2X))
0070 GO TO 9
0071 WRITE (6,209) RUN(K),PFAR(K),VASL(K),(VEL (I,K),I=1,N)
0072 FORMAT (7X,F7.3,5X,F6.3,9X,F5.3,13X,5HCLEAR,9X,6(F6.4,2X))
0073 CONTINUE
0074 CONTINUE
0075 STPIX=0.0
0076 STPHIN=50.0
0077 CALL STATUS (STP,NT,STPH,STPHX,STPHI,STPSD)
0078 PFANX=0.0
0079 PFAHN=100.0
0080 CALL STATUS (PFAS,NS,PFAN,PFANX,PFAIN,PFASD)
0081 VASHX=0.0

```

```

0082 VASIN=9.6
0083 CALL STATIS (VASL,NS,VARN,VASIX,VASIN,VASSD)
0084 DO 12 J=1,N
0085 DO 11 K=1,NS
0086 VLCTV(K)=VEL(J,K)
0087 CONTINUE
0088 VLCHX=0.0
0089 VLCHN=5000.0
0090 CALL STATIS (VLCTY,NS,VICH,VLCHX,VLCHN,VLCSD)
0091 VELH(J)=VLCH
0092 VELHX(J)=VLCHX
0093 VELHN(J)=VLCHN
0094 VELSD(J)=VLCSD
0095 CONTINUE
0096 WRITE (6,210) RUIN(1),RUH(NS)
0097 FORMAT (1H1,/,/,20X,15HTPEST NUMBERS = ,F8.3,6H TO ,F8.3)
0098 WRITE (6,211)
0099 FORMAT (/,/,17X,11HFLUSH AHEAD,4X,11HFLUSH AHEAD,5X,
0100 11HNDIST. TO STOP,20X,14HVELOCITY, 11/S.)
0101 WRITE (6,212)
0102 FORMAT (18X,10HSOLID (X),,5X,10HSOLID (L),,5X,
0103 114HFRUIT W.C. (H).)
0104 WRITE (6,213) PFAH,VASH,STP1,(VELH(J),J=1,N)
0105 FORMAT (/,/,7X,5HNEAR,,7X,F6.3,9X,F5.3,13X,F5.2,9X,6(F6.4,2X))
0106 WRITE (6,214) PFAHX,VASIX,STPIX,(VELHX(J),J=1,N)
0107 FORMAT (7X,6HMAX,,8X,F6.3,9X,F5.3,13X,F5.2,9X,6(F6.4,2X))
0108 WRITE (6,215) PFAHN,VASIN,STPIN,(VELHN(J),J=1,N)
0109 FORMAT (7X,6HMIN,,8X,F6.3,9X,F5.3,13X,F5.2,9X,6(F6.4,2X))
0110 WRITE (6,216) PFASD,VASND,STPSD,(VELSD(J),J=1,N)
0111 FORMAT (7X,7HST.DEV.,5X,F6.3,9X,F5.3,13X,F5.2,9X,6(F6.4,2X),/)
0112 V1=0.0
0113 V2=0.0001
0114 WRITE (6,217)
0115 FORMAT (/,/,25X,24HVELOCITY INTERVAL, H/S.)
0116 GO TO 14
0117 V1=V2
0118 V2=V1+0.1
0119 IF (V1.EQ.0.0001) V2=0.1
0120 CONTINUE
0121 DO 15 J=1,N
0122 IF (V2.GT.VELHN(J)) GO TO 14
0123 CONTINUE
0124 GO TO 13
0125 DO 17 J=1,N
0126 IF (V1.LE.VELHX(J)) GO TO 14
0127 CONTINUE
0128 GO TO 21
0129 DO 20 J=1,N
0130 NTOTAL(J)=0
0131 DO 19 K=1,NS
0132 IF (VEL(J,K).LT.V2.AND.VEL(J,K).GE.V1) HTOTAL(J)=HTOTAL(J)+1
0133 CONTINUE
0134 CONTINUE
0135 WRITE (6,218) V1,V2,(NTOTAL(J),J=1,N)
0136 FORMAT (/,/,27X,F6.4,6H TO ,F6.4,16X,6(16,2X))
0137 GO TO 13
0138 CONTINUE
0139 READ (5,100) LABL
0140 IF (LABL.EQ.6) GO TO 4

```

0143
0142

STOP
END

END OF SEGMENT, LENGTH 963, NAME DREG

```

0143 SUBROUTINE STATIS (X,H,XM,XIX,XIIN,XSD)
0144 DIMENSION X(100)
0145 SUM1=0.0
0146 SUM2=0.0
0147 NZ=1
0148 IF (N.EQ.0) GO TO 10
0149 DO 1 J=1,H
0150 IF (X(J).LT.0.0) GO TO 4
0151 SUM1=SUM1+X(J)
0152 IF (X(J).GT.XIIX) XIIX=X(J)
0153 IF (X(J).LT.XIIN) XIIN=X(J)
0154 GO TO 1
0155 NZ=NZ-1
0156 CONTINUE
0157 XIISUM1/FLOAT(NZ)
0158 DO 2 J=1,N
0159 IF (X(J).LT.0.0) GO TO 7
0160 SUM2=SUM2+(X(J)-XIIN)**2
0161 CONTINUE
0162 CONTINUE
0163 XSD=SQRT(SUM2/FLOAT(NZ))
0164 GO TO 9
0165 XIIN=0.0
0166 XIIX=0.0
0167 XIIN=0.0
0168 XSD=0.0
0169 CONTINUE
0170 RETURN
0171 END

```

9
1
7
2
10
9

END OF SEGMENT, LENGTH 214, NAME STATIS

0172 FINISH

END OF COMPILATION - NO ERRORS

```

S/C SUBFILE : 26 BUCKETS USED
FIRST WORKFILE : 37 BUCKETS USED
SECOND WORKFILE : 26 BUCKETS USED
19.41.53 0.31 CORE GIVEN 11392
( 19.42.13 FREE *LPO ,16 TRANSFERS
19.42.20 FREE *DA1 ,20 TRANSFERS
( 19.42.24 FREE *DA2 ,77 TRANSFERS
19.42.24 FREE *DA13,7 TRANSFERS
( 19.42.30 0.39 CORE GIVEN 7936,CLOCKED 0.06
0.39 :HALTED ; LD

```

A1 - 6 Sample Printout.

HOSPITAL DRAINAGE DESIGN - DECELERATION CHARACTERISTICS.
 DR. J. A. SHAFFIELD AND S. D. BOKOR. - DRAINAGE RESEARCH GROUP,
 DEPARTMENT OF BUILDING TECHNOLOGY, - BRUNEL UNIVERSITY.

APRIL 26TH 1978. TEST NUMBER 10.
 AIRLIFT SHANKS P-TRAP BACK ENTRY LOW LEVEL W.C. VENTED DISCHARGE.
 SOLID DECELERATION SERIES. 14.227 METRES OF STRAIGHT PLASTIC PIPE.
 GRADIENT OF 1/80. CUT MAT. PAD - FULL WIDTH (35MM), 226MM LENGTH.

RUN NO.	FLUSH AHEAD SOLID (%):		FLUSH AHEAD SOLID (L):	DIST. TO STOP FROM W.C. (M).	NUMBER OF W.C. FAILURES = 0						VELOCITY, M/S:					
	8.750	10.000			10.000	11.250	13.750	15.000	8.750	6.250		10.000	11.250	12.500	10.000	13.750
10.010	8.750	10.000	0.796	CLEAR	0.6887	0.7778	0.9016	0.6806	0.4107	0.3968						
10.020	10.000	10.000	0.910	CLEAR	0.6578	0.7782	0.6439	0.5210	0.4272	0.4188						
10.030	10.000	10.000	0.910	CLEAR	0.6543	0.7308	0.6019	0.6129	0.3888	0.3604						
10.040	11.250	11.250	1.024	CLEAR	0.7037	0.7667	0.6036	0.6056	0.3932	0.3595						
10.050	13.750	13.750	1.251	CLEAR	0.6662	0.7231	0.5185	0.3827	0.3560	0.3442						
10.060	11.250	11.250	1.024	CLEAR	0.7013	0.7487	0.6271	0.6615	0.4087	0.3803						
10.070	15.000	15.000	1.365	CLEAR	0.7126	0.7872	0.5529	0.6199	0.3874	0.3747						
10.080	8.750	8.750	0.796	CLEAR	0.7255	0.9110	0.6160	0.5199	0.4256	0.3929						
10.090	6.250	6.250	0.569	CLEAR	0.6859	0.7491	0.6797	0.5184	0.4357	0.4025						
10.100	10.000	10.000	0.910	CLEAR	0.7406	0.7461	0.6103	0.6694	0.4092	0.3936						
10.110	11.250	11.250	1.024	CLEAR	0.7448	0.7442	0.5984	0.6985	0.6011	0.3813						
10.120	12.500	12.500	1.137	CLEAR	0.6904	0.8235	0.6328	0.6660	0.3968	0.3725						
10.130	10.000	10.000	0.910	CLEAR	0.7133	0.7758	0.5966	0.6682	0.3861	0.3660						
10.140	13.750	13.750	1.251	CLEAR	0.6187	0.6936	0.5139	0.3766	0.3424	0.3181						
10.150	23.750	23.750	2.161	CLEAR	0.7346	0.8188	0.5679	0.3658	0.3499	0.3385						
10.160	15.000	15.000	1.365	CLEAR	0.6985	0.7004	0.5733	0.6093	0.3720	0.3552						
10.170	15.000	15.000	1.365	CLEAR	0.8075	0.8039	0.5468	0.6157	0.3853	0.3629						
10.180	13.750	13.750	1.251	CLEAR	0.6434	0.7742	0.5739	0.6040	0.3682	0.3396						
10.190	23.750	23.750	2.161	CLEAR	0.6667	0.7704	0.5027	0.3539	0.3393	0.3286						
10.200	20.000	20.000	1.820	CLEAR	0.7593	0.8045	0.5134	0.3609	0.3445	0.3443						
10.210	13.750	13.750	1.251	CLEAR	0.6368	0.8532	0.5627	0.4365	0.3855	0.3663						
10.220	12.500	12.500	1.137	CLEAR	0.7227	0.9036	0.5924	0.4917	0.4198	0.3968						
10.230	13.750	13.750	1.251	CLEAR	0.6106	0.6927	0.5567	0.4264	0.3942	0.3741						
10.240	13.750	13.750	1.251	CLEAR	0.6363	0.7720	0.5877	0.4219	0.3751	0.3745						
10.250	11.250	11.250	1.024	CLEAR	0.6761	0.7724	0.5465	0.4231	0.3997	0.3858						
10.260	11.250	11.250	1.024	CLEAR	0.6849	0.8774	0.6639	0.6736	0.6079	0.3988						
10.270	11.250	11.250	1.024	CLEAR	0.5943	0.7632	0.6188	0.6481	0.3918	0.3840						
10.280	6.250	6.250	0.569	CLEAR	0.7391	0.8069	0.6748	0.5227	0.4272	0.4066						
10.290	11.250	11.250	1.024	CLEAR	0.6708	0.7889	0.6249	0.5050	0.4337	0.4110						
10.300	11.250	11.250	1.024	CLEAR	0.6821	0.7985	0.6643	0.6548	0.3899	0.3781						
10.310	11.250	11.250	1.024	CLEAR	0.6383	0.7481	0.5937	0.6516	0.4061	0.3965						
10.320	12.500	12.500	1.137	CLEAR	0.6382	0.8713	0.6035	0.5018	0.4189	0.4036						

APPENDIX II

A2 MASTER GREENWICH COMPUTER PROGRAM

A2 - 1 Listing of Variable Names

- LABL - indicates the type of data to be read into the program.
- LABL 1 - indicates alphanumeric data (headings etc).
- LABL 2 - indicates data which remains constant for any one particular experiment.
- LABL 3 - indicates data which must be recorded for each flush of the W.C.
- LABL 25 - indicates that a complete new set of data is to be fed in, followed by a complete re-run of the program. After LABL 25, new type 1, 2 and 3, data is fed in.
- NR = The Number of flushes, (number of runs).
- NT = The Number of cases where the solid stops in the pipe.
- M = The Computer Check Number, (eg. 25th data analysis).
- N = The Number of Velocity Measurement Points.
- XTRAL = Distance from 'Input Device' to 135° junction.
- PSPD = Pen Recorder Chart-paper speed.
- POS(N) = Distance from 135° junction to Velocity Measurement Point.
- SP(N) = Separation between Photocells.
- POSN(N) = Distance from 'Input Device' to Velocity Measurement Point.
- IRN = The Run Number, (eg. 156th flush).
- ISLDN = Position of solid in flush, (eg. 1st, 2nd, 3rd etc).
- NSLDS = Total number of solids in flush.
- STPP = Stoppage position, measured from 135° junction.
- IDIST(N) = Length of Chart-paper travel, between photocell pulses.

NA	=	First number of code describing solid	}	See Section 8.7 and Figure 8/13.
NB	=	Second " " " " " "		
NC	=	Third " " " " " "		
ND	=	Fourth " " " " " "		
NE	=	Fifth " " " " " "		
NF	=	Sixth " " " " " "		

IRUN(NR) = Values of IRN, stored in an array
ISOLDN(NR) = Values of ISLDN, stored in an array
NSOLDS(NR) = Values of NSLDS, stored in an array
STP(NT) = Stoppage position, measured from 'input device'.

NAX(NR) = Values of NA, stored in an array.
NBX(NR) = " NB, " " " "
NCX(NR) = " NC, " " " "
NDX(NR) = " ND, " " " "
NEX(NR) = " NE, " " " "
NFX(NR) = " NF, " " " "

DIST(N) = Conversion to 'real' number, of 'integer' IDIST.
TIME = Time taken for 'solid to travel distance, SP(N),
VEL(NR,N) = Values of Solid Velocity, as measured at each Velocity
Point, stored in an array.

STPM = Mean of values of STP(NT)
STPMX = Maximum value of STP(NT)
STPMN = Minimum value of STP(NT)
STPSD = Standard deviation of values of STP(NT).

VLCTY(NR) = Values of Solid Velocity, as measured at one Velocity
Point only.

VLCM = Mean of values of VLCTY(NR)
VLCMX = Maximum value of VLCTY(NR)
VLCMN = Minimum value of VLCTY(NR)
VLCSD = Standard deviation of values of VLCTY(NR).

VELM(N) = Values of VLCM stored in an array
VELMX(N) = Values of VLCMX stored in an array
VELMN(N) = Values of VLCMN stored in an array
VELSD(N) = Values of VLCSD stored in an array.

NTOTAL(N) = Number of velocities in particular interval, for
one velocity point.

V1 = Lower limit of histogram interval.
V2 = Upper limit of histogram interval.

A2 - 2 Data Controls

If a value of IDIST(N) equal to zero is fed into the program, this is taken to mean that velocity is equal to zero, and NOT that velocity is infinite.

If a value of STPP equal to zero is fed into the program, this is taken to mean that there is no stoppage position as the solid cleared the monitored length of pipework.

If a value of IRN equal to zero is fed into the program, this is taken to indicate an end of LABL 3 data, and the program will not compute if further LABL 3 data has been entered.

At the end of the program, if a further complete new set of data is not available for analysis, insertion of any value of LABL, other than 25, will cause the program to terminate. For convenience, and to save confusion, a value of LABL equal to zero was used for this purpose.

A2 - 3 Program Listing.

#LISTING OF 'BT.SD-SITE(1/B1BU)' PRODUCED ON 10NOV81 AT 13.52.11
#OUTPUT BY LISTFILE IN 'BT.SD-SITE' ON 10NOV81 AT 13.53.05 USING 3

DOCUMENT 'BT.SD-SITE(/B1B0)

STARTED 'BT.SD-SITE,10NOV81 , 13.48.55 TYPE:BACK
13.48.55+ JOB SD-SITE,'BT
13.48.55+ SD-SITE
13.48.55+ BFORTRAN SD-SOURCE1,SD-DATA1,CLIST,TIME 1000
13.48.56+ TA AB,CM
13.48.58 JOB IS NOW FULLY STARTED
13.49.01 0.02 CORE GIVEN 32576
0.13 : HALTED : BP
0.13 : HALTED : BP
13.50.01 FREE *DA3 ,29 TRANSFERS
13.50.01 FREE *CRO ,235 TRANSFERS
13.50.01 FREE *DA1 ,113 TRANSFERS
13.50.02 FREE *DA4 ,15 TRANSFERS
0.37 : DELETED : FI
13.50.02 FREE *DAO ,249 TRANSFERS
13.50.02 FREE *LPO ,263 TRANSFERS
13.50.02 0.37 DELETED,CLOCKED 0.29

FORTRAN COMPILATION BY #XFIV IJK 38 DATE 10/11/81 TIME 13/49/06

0000 PROGRAM (SITE)
0001 INPUT 5=CRO
0002 OUTPUT 6=LPO
0003 TRACE 2
0004 END

0005 MASTER GREENWICH
0006 DIMENSION E(9),POB(9),SP(9),PUSH(9),IDIST(9),IRUN(500),
0007 IISJLDN(200),NSOLDS(500),STPPN(500) STP(500),MAX(500),NBX(500),
0008 2NCX(500),NDX(500),NEX(500),NFX(500),DIST(500),VEL(500,9),
0009 3VLCY(500),VELM(9),VELMX(9),VELMH(9),VELSD(9),MFOY(9)
0010 WRITE (6,200)
0011 FORMAT (1H1,/,/,20X,
0012 140HGREENWICH DISTRICT HOSPITAL, ON SITE.,/,20X,
0013 240HMONITORING OF ABOVE GROUND DRAINAGE.,/,20X,
0014 340HDR.J.A.SHAFFIELD AND MR.S.D.BOKOR.,/,20X,
0015 440HDRAINAGE RESEARCH GROUP, - DEPARTMENT OF.,/,20X,
0016 540HBUILDING TECHNOLOGY - BRUNEL UNIVERSITY.,/)
0017 NR=J
0018 NT=0
0019 READ (5,100) LABL
0020 GO TO (I,2,3),LABL
0021 READ (5,101) (E(I),I=1,9)
0022 FORMAT (10)
0023 FORMAT (9A8)

```

0024 WRITE (0,201) (E(I),I=1,9)
0025 FORMAT (20X,9A8)
0026 GO TO 6
0027 READ (5,102) M,N,XTRAL,PSPD,(POS(I),I=1,N)
0028 FORMAT (210,11F0.0)
0029 READ (5,132) (SP(I),I=1,N)
0030 FORMAT (9F0.0)
0031 DO 9 I=1,N
0032 POSN(I)=POS(I)+XTRAL
0033 CONTINUE
0034 GO TO 6
0035 READ (5,103) IRN,ISLDN,NSLDS,STPP,(IDIST(I),I=1,N),
0036 1MA,NB,NC,HD,NE,NF
0037 FORHAT (310,F0.0,1510)
0038 IF (IRN.EQ.0) GO TO 8
0039 NR=NR+1
0040 IRUN(NR)=IRN
0041 ISOLDN(JR)=ISLDN
0042 NSLDS(NR)=NSLDS
0043 IF (STPP.EQ.0.0) GO TO 11
0044 STPP(NR)=STPP+XTRAL
0045 NT=NT+1
0046 STP(NT)=STPP(NR)
0047 GO TO 12
0048 STPP(NR)=0.0
0049 CONTINUE
0050 MAX(NR)=NA
0051 NBX(NR)=NB
0052 NCX(NR)=NC
0053 NDX(NR)=ND
0054 NEX(NR)=NE
0055 NFX(NR)=NF
0056 DO 4 I=1,N
0057 IF (IDIST(I).EQ.0) GO TO 5
0058 DIST(I)=FLOAT (IDIST(I))/(10.0**3)
0059 TIME=DIST(I)/PSPD
0060 VEL(NR,I)=SP(I)/TIME
0061 GO TO 7
0062 VEL(NR,I)=0.0
0063 CONTINUE
0064 CONTINUE
0065 GO TO 3
0066 CONTINUE
0067 WRITE (0,202) NR
0068 FORMAT (/,20X,34HNUMBER OF RUNS UNDER COMPARISON =,I4,2H //)
0069 WRITE (0,203) (I,I=1,N)
0070 FORMAT (20X,27HVVELOCITY MEASURING POINT. 9(16,2X),)
0071 WRITE (6,204) (POSN(I),I=1,N)
0072 FORMAT (20X,27HDISTANCE (M) FRO. U.C. .9F8.3)
0073 WRITE (6,205) (SP(I),I=1,N)
0074 FORMAT (20X,27HSENSOR SEPARATION (H) . .9F8.1)
0075 WRITE (6,206)
0076 FORMAT (/,2X,5HRUN ,17HRELATIVE OSN- ,16HCLASSIFICATION ,
0077 15HSTOP ,32X,14HVELOCITY, M/S.)
0078 WRITE (0,207)
0079 FORMAT (2X,5HNO. ,17HSOLID IN FLU.H. ,
0080 116HO. OF SOLID. ,5HPOSN.//)
0081 DO 10 K=1,NR
0082 IF (STP(N(K)).EQ.0.0) GO TO 60J

```

```

0083 IF (NSOLDS(K).EQ.1) GO TO 500
0084 IF (ISOLDN(K).EQ.1) GO TO 501
0085 IF (ISO-DN(K).EQ.2) GO TO 502
0086 IF (ISOLDN(K).EQ.3) GO TO 503
0087 WRITE (0,208) IRUN(K),ISOLDN(K),NSOLDS(K),NAX(K),NBX(K),NCX(K),
0088 1NDX(K),HFX(K),NFX(K),STPPN(K),(VEL(K,I),I=1,N)
0089 FORMAT (15,2X,I1,6HTH OF ,I1,7H SOLIDS,2X,I1,1H/,12,1H/,
0090 112,1H/,I1,1H/,I1,1X,F6.3,2X,9(2X,F6.4))
0091 GO TO 800
0092 WRITE (0,209) IRUN(K),NAX(K),NBX(K),NCX(K),NDX(K),NFX(K),
0093 1STPPN(K),(VEL(K,I),I=1,N)
0094 FORMAT (15,2X,I1,6HTH OF ,I1,11,1H/,12,1H/,12,1H/,
0095 112,1H/,I1,1H/,I1,1X,F6.3,2X,9(2X,F6.4))
0096 GO TO 800
0097 WRITE (0,210) IRUN(K),ISOLDN(K),NSOLDS(K),NAX(K),NBX(K),NCX(K),
0098 1NDX(K),HFX(K),NFX(K),STPPN(K),(VEL(K,I),I=1,N)
0099 FORMAT (15,2X,I1,6HTH OF ,I1,7H SOLIDS,2X,I1,1H/,12,1H/,12,1H/,
0100 112,1H/,I1,1H/,I1,1X,F6.3,2X,9(2X,F6.4))
0101 GO TO 800
0102 WRITE (0,211) IRUN(K),ISOLDN(K),NSOLDS(K),NAX(K),NBX(K),NCX(K),
0103 1NDX(K),HFX(K),NFX(K),STPPN(K),(VEL(K,I),I=1,N)
0104 FORMAT (15,2X,I1,6HTH OF ,I1,7H SOLIDS,2X,I1,1H/,12,1H/,12,1H/,
0105 112,1H/,I1,1H/,I1,1X,F6.3,2X,9(2X,F6.4))
0106 GO TO 800
0107 WRITE (0,212) IRUN(K),ISOLDN(K),NSOLDS(K),NAX(K),NBX(K),NCX(K),
0108 1NDX(K),HFX(K),NFX(K),STPPN(K),(VEL(K,I),I=1,N)
0109 FORMAT (15,2X,I1,6HTH OF ,I1,7H SOLIDS,2X,I1,1H/,12,1H/,12,1H/,
0110 112,1H/,I1,1H/,I1,1X,F6.3,2X,9(2X,F6.4))
0111 GO TO 800
0112 CONTINUE
0113 IF (NSOLDS(K).EQ.1) GO TO 700
0114 IF (ISO-DN(K).EQ.1) GO TO 701
0115 IF (ISOLDN(K).EQ.2) GO TO 702
0116 IF (ISOLDN(K).EQ.3) GO TO 703
0117 WRITE (0,213) IRUN(K),ISOLDN(K),NSOLDS(K),NAX(K),NBX(K),NCX(K),
0118 1NDX(K),HFX(K),NFX(K),(VEL(K,I),I=1,N)
0119 FORMAT (15,2X,I1,6HTH OF ,I1,7H SOLIDS,2X,I1,1H/,12,1H/,12,1H/,
0120 112,1H/,I1,1H/,I1,1X,6H CLEAR,2X,9(2X,F6.4))
0121 GO TO 800
0122 WRITE (0,214) IRUN(K),NAX(K),NBX(K),NCX(K),NDX(K),NFX(K),
0123 1VEL(K,I),I=1,N)
0124 FORMAT (15,2X,I1,6HTH OF ,I1,11,1H/,12,1H/,12,1H/,
0125 112,1H/,I1,1H/,I1,1X,6H CLEAR,2X,9(2X,F6.4))
0126 GO TO 800
0127 WRITE (0,215) IRUN(K),ISOLDN(K),NSOLDS(K),NAX(K),NBX(K),NCX(K),
0128 1NDX(K),HFX(K),NFX(K),(VEL(K,I),I=1,N)
0129 FORMAT (15,2X,I1,6HTH OF ,I1,7H SOLIDS,2X,I1,1H/,12,1H/,12,1H/,
0130 112,1H/,I1,1H/,I1,1X,6H CLEAR,2X,9(2X,F6.4))
0131 GO TO 800
0132 WRITE (0,216) IRUN(K),ISOLDN(K),NSOLDS(K),NAX(K),NBX(K),NCX(K),
0133 1NDX(K),HFX(K),NFX(K),(VEL(K,I),I=1,N)
0134 FORMAT (15,2X,I1,6HTH OF ,I1,7H SOLIDS,2X,I1,1H/,12,1H/,12,1H/,
0135 112,1H/,I1,1H/,I1,1X,6H CLEAR,2X,9(2X,F6.4))
0136 GO TO 800
0137 WRITE (0,217) IRUN(K),ISOLDN(K),NSOLDS(K),NAX(K),NBX(K),NCX(K),
0138 1NDX(K),HFX(K),NFX(K),(VEL(K,I),I=1,N)
0139 FORMAT (15,2X,I1,6HTH OF ,I1,7H SOLIDS,2X,I1,1H/,12,1H/,12,1H/,
0140 112,1H/,I1,1H/,I1,1X,6H CLEAR,2X,9(2X,F6.4))
0141 CONTINUE
800

```



```

0142 CONTINUE
0143 WRITE (6,218) M
0144 FORMAT (///,20X,18HCOMPUTER CHECK NO.,I6)
0145 STPMX=0.0
0146 STPHN=50.0
0147 CALL STATIS (STB,NT,STPH,STPMX,STPH,STPSD)
0148 DO 14 J=1,N
0149 DO 13 K=1,NR
0150 VLCTY(K)=VEL(K,J)
0151 CONTINUE
0152 VLCHX=0.0
0153 VLCHN=5000.0
0154 CALL STATIS (VLCTY,NR,VLCHM,VLCHX,VLCHN,VLCSO)
0155 VELH(J)=VLCH
0156 VELHX(J)=VLCHX
0157 VELMN(J)=VLCHN
0158 VE_S(D(J))=VLCSO
0159 CONTINUE
0160 WRITE (6,219)
0161 FORMAT (1H1,(/,31X,14HDIST. 10 S:OP,32X,14HVELOCITY, H/S.)
0162 WRITE (6,220)
0163 FORIAT (31X,14HFROM W.C. (M.))
0164 WRITE (6,221) STPH, (VELH(J),J=1,N)
0165 FORIAT (/ ,20X,7HMEAN. ,8X,F6.3,6X.9(2X,F6.4))
0166 WRITE (6,222) STPMX, (VELMX(J),J=1,N)
0167 FORIAT (20X,7HHAX. ,8X,F6.3,6X.9(2X,F6.4))
0168 WR LCE (6,223) STPHN, (VELMN(J),J=1,N)
0169 FORIAT (20X,7HMIN. ,8X,F6.3,6X.9(2X,F6.4))
0170 WRITE (6,224) STPSD, (VELSD(J),J=1,N)
0171 FORIAT (20X,7HST.DEV.,8X,F6.3,6X.9(2X,F6.4))
0172 V1=0.0
0173 V2=0.00V1
0174 WRITE (6,225)
0175 FORIAT (//,12X,24HVELOCITY INTERVAL, H/S.)
0176 GO TO 16
0177 V1=V2
0178 V2=V1+0.1
0179 IF (V1.EQ.0.0001) V2=0 1
0180 CONTINUE
0181 DO 17 J=1,N
0182 IF (V2.GT.VELMN(J)) GO TO 18
0183 CONTINUE
0184 GO TO 17
0185 DO 19 J=1,N
0186 IF (V1.LE.VELMX(J)) GO TO 20
0187 CONTINUE
0188 GO TO 23
0189 DO 22 J=1,N
0190 NTOTAL(J)=0
0191 DO 21 K=1,NR
0192 IF (VEL(K,J)).LT.V2.AND.VEL(K,J).GE.V1) NTOTAL(J)=NTOTAL(J)+1
0193 CONTINUE
0194 CONTINUE
0195 WRITE (6,226) V1,V2,(NTOTAL(J),J=1,N)
0196 FORIAT (/ ,14X,F6.4,8H TO ,F6.4,10X,9(2X,I6),
0197 GO TO 15
0198 CONTINUE
0199 WRITE (6,227) M
0200 FORMAT (///,20X,18HCOMPUTER CHECK NO.,I6)

```

```

0201 READ (5,100) LABL
0202 IF (LABL.EQ.25) GO TO 25
0203 STUP
0204 END

```

END OF SEGMENT, LENGTH 1570, NAME GREENWICH

```

0205 SUBROUTINE STATIS (X,N,XM,XXM,XIHN,SD)
0206 DIMENSION X(500)
0207 SUM1=0.0
0208 SUM2=0.0
0209 NZ=H
0210 IF (N.EQ.0) GO TO 10
0211 DO 1 J=1,N
0212 IF (X(J).LT.0.0) GO TO 6
0213 SUM1=SUM1+X(J)
0214 IF (X(J).GT.XM) XXM=X(J)
0215 IF (X(J).LT.XMN) XMN=X(J)
0216 GO TO 1
0217 NZ=NZ-1
0218 CONTINUE
0219 XM=SUM1/FLOAT(NZ)
0220 DO 2 J=1,N
0221 IF (X(J).LT.0.0) GO TO 7
0222 SUM2=SUM2+(X(J)-XM)**2
0223 CONTINUE
0224 CONTINUE
0225 XSD=SQRT(SUM2/FLOAT(NZ))
0226 GO TO 9
0227 XM=0.0
0228 XXM=0.0
0229 XMN=0.0
0230 XSD=0.0
0231 CONTINUE
0232 RETURN
0233 END

```

6
1
7
2
10
9

END OF SEGMENT, LENGTH 214, NAME STATIS

0234 FINISH

END OF COMPILATION - NO ERRORS

S/C SUBFILE : 36 BUCKETS USED

FIRST WORKFILE : 63 BUCKETS USED

SECOND WORKFILE : 40 BUCKETS USED

13.50.14 0.42 CORE GIVEN 11392
13.50.23 0.45 CORE GIVEN 28689,CLOCKED 0.02
13.50.24 FREE *LP0 ,16 TRANSFERS
13.50.33 FREE *DA1 ,23 TRANSFERS
13.50.35 FREE *DA2 ,77 TRANSFERS
13.50.33 FREE *DA13,7 TRANSFERS

13.50.34 0.50 CORE GIVEN 28416,CLOCKED 0.07
0.51 ; HALTED ; LD

CONSOLIDATED BY XPCK 12J DATE 10/11/81 TIME 13/56/14

PROGRAM SITE
EXTENDED DATA (22AM)
COMPACT PROGRAM (DBM)
CORE 28416

SEG GREENWICH
SEG FLOAT
SEG STATIS
SEG SURT
13.52.05 FREE *CRO /254 TRANSFERS
13.52.06 FREE *LPO /685 TRANSFERS
1.59 : DELETED : 00
13.52.06 FREE *DA15,0 TRANSFERS
13.52.06 1.59 DELETED,CLOCKED 1.12
END OF MACRO
END OF MACRO
MAXIMUM ONLINE BS USED 140 KHURDS
13.52.10 2.01 FINISHED I 2 LISTFILES

↑*****↑
↑*****↑

TEXT BOUND INTO

THE SPINE

A2 - 4 Sample Printout.

COMPUTER CHECK NO. 1122

GREENWICH DISTRICT HOSPITAL, ON SITE
MONITORING OF ABOVE GROUND DRAINAGE,
DR. J.A. SWAFFIELD AND MR. S.D. BUCK,
DRAINAGE RESEARCH GROUP, DEPARTMENT OF
BUILDING TECHNOLOGY - BRUNEL UNIVERSITY,

RED W.C. GRADIENT = 1:150.

FEMALE SUITE OF W.C. S.
LAST SOLID OF FLUSH, IRRESPECTIVE
OF COMPOSITION OR NUMBER OF SOLIDS.

NUMBER OF RUNS UNDER COMPARISON = 362.

VELOCITY MEASURING POINT:
DISTANCE (M) FROM W.C. 3.150
SENSOR SEPARATION (M) 1.00

RUN NO.	RELATIVE POSITION OF SOLID IN FLUSH	PUSH NO. OF SOLID	CLASSIFICATION STOP POSN.	VELOCITY M/S.								
				1	2	3	4	5	6	7	8	9
1	NU OTHER SOLID	2/ 9/15/ U/3/0	CLEAR	1.1111	1.4195	0.9604	0.9091	0.9259	0.8621	0.8712	0.7937	0.7576
2	NU OTHER SOLID	2/ 7/14/ U/3/0	CLEAR	1.1023	0.9804	0.8197	0.7576	0.7463	0.6579	0.6175	0.5102	0.4464
3	NU OTHER SOLID	2/ 7/15/ U/3/0	CLEAR	0.9259	0.9804	0.8849	0.5155	0.3205	0.1818	0.2137	0.2053	0.1712
4	NU OTHER SOLID	2/11/14/ U/3/0	CLEAR	1.0658	0.6621	0.8197	0.7937	0.6944	0.5618	0.4950	0.3247	0.1984
5	NU OTHER SOLID	2/ 7/14/ U/3/0	CLEAR	1.0070	1.0417	0.8197	0.7692	0.7246	0.6757	0.6494	0.5102	0.3906
6	NU OTHER SOLID	2/ 7/15/ U/3/0	CLEAR	1.1111	1.0658	1.0000	0.9091	0.8929	0.8475	0.8475	0.7576	0.7463
7	NU OTHER SOLID	2/10/14/ U/3/0	CLEAR	1.0417	1.0658	0.8772	0.8333	0.7692	0.6944	0.6494	0.5882	0.5051
8	NU OTHER SOLID	2/ 7/15/ U/3/0	CLEAR	0.9804	1.0000	0.8197	0.7576	0.6667	0.6024	0.5319	0.4274	0.3556
9	NU OTHER SOLID	2/ 9/15/ U/3/0	CLEAR	1.0417	1.0658	0.8197	0.8849	0.8098	0.4052	0.2959	0.1730	0.1457
10	NU OTHER SOLID	2/ 7/15/ U/3/0	CLEAR	1.0658	1.0417	0.8772	0.8475	0.8197	0.7246	0.6849	0.5618	0.5000
11	NU OTHER SOLID	2/11/14/ U/3/0	CLEAR	1.0070	1.1628	0.8929	0.8475	0.8333	0.7576	0.7246	0.5882	0.5051
12	NU OTHER SOLID	2/ 9/14/ U/3/0	CLEAR	1.0070	1.0870	0.8454	0.9091	0.8475	0.6197	0.6929	0.7463	0.7553
13	NU OTHER SOLID	2/ 9/14/ U/3/0	CLEAR	1.1111	1.1364	0.8475	0.8475	0.8621	0.8065	0.7246	0.5952	0.5618
14	NU OTHER SOLID	2/ 7/14/ U/3/0	CLEAR	1.1364	1.0658	0.8772	0.8621	0.7692	0.6757	0.6494	0.4950	0.3937
15	NU OTHER SOLID	2/ 7/14/ U/3/0	CLEAR	1.0417	1.0000	0.7553	0.6667	0.5556	0.4675	0.3846	0.2459	0.2404
16	NU OTHER SOLID	2/ 7/14/ U/3/0	CLEAR	1.1111	1.0870	0.7937	0.8333	0.8333	0.7576	0.6944	0.5814	0.5747
17	NU OTHER SOLID	2/ 7/15/ U/3/0	CLEAR	1.1364	1.0658	0.8929	0.8333	0.8197	0.7815	0.8553	0.7553	0.6410
18	NU OTHER SOLID	2/11/14/ U/3/0	CLEAR	1.0658	1.1364	0.9615	0.9615	0.9259	0.8197	0.8929	0.7576	0.7815
19	NU OTHER SOLID	2/ 7/15/ U/3/0	CLEAR	1.0204	1.0870	0.8333	0.7937	0.7463	0.6849	0.6667	0.5155	0.4310
20	NU OTHER SOLID	2/15/15/ U/3/0	CLEAR	1.0000	1.0658	0.8772	0.7576	0.6024	0.5155	0.4257	0.2392	0.1852
21	NU OTHER SOLID	2/12/14/ U/3/0	CLEAR	1.0000	1.0870	0.8553	0.7937	0.7333	0.6250	0.5102	0.4675	0.3846
22	NU OTHER SOLID	2/ 4/15/ U/3/0	10.540	0.9804	0.8553	0.5937	0.2941	0.1538	0.2174	0.2008	0.0000	0.0000
23	NU OTHER SOLID	2/12/14/ U/3/0	CLEAR	1.0658	1.0870	0.9259	0.7815	0.7692	0.7333	0.7246	0.6250	0.5618
24	NU OTHER SOLID	2/ 7/14/ U/3/0	CLEAR	1.0658	1.1905	0.9615	0.9091	0.9615	0.8475	0.8621	0.7937	0.7463
25	NU OTHER SOLID	7/ 0/ 0/25/1/0	CLEAR	1.1364	1.1628	0.8475	1.0417	0.9804	1.0000	0.7815	0.8621	0.7937
26	NU OTHER SOLID	2/ 9/14/ U/3/0	CLEAR	1.0417	1.1905	0.9259	0.8065	0.7576	0.7576	0.7937	0.6757	0.5882
27	NU OTHER SOLID	2/ 4/13/ U/3/0	10.540	1.0417	1.1111	0.8065	0.6667	0.5376	0.5401	0.1260	0.0000	0.0000
28	NU OTHER SOLID	2/ 5/15/ U/3/0	CLEAR	1.0670	1.1905	1.0000	0.872	0.8333	0.8197	0.7815	0.6579	0.5952
29	NU OTHER SOLID	4/12/15/ U/3/0	CLEAR	1.0000	1.0000	0.8621	0.7692	0.7463	0.6667	0.7333	0.6024	0.5453
30	NU OTHER SOLID	2/ 9/15/ U/3/0	CLEAR	1.0417	1.1628	0.9615	0.8197	0.8675	0.8475	0.8553	0.6757	0.6410
31	NU OTHER SOLID	2/11/15/ U/3/0	CLEAR	1.0638	1.0870	0.9091	0.9434	0.8629	0.8333	0.9091	0.7815	0.7042
32	NU OTHER SOLID	2/10/14/ U/3/0	CLEAR	1.0870	1.0204	0.8621	0.7463	0.7042	0.6757	0.6024	0.5906	0.2646
33	NU OTHER SOLID	2/15/15/ U/3/0	CLEAR	1.1364	1.1111	0.8621	0.8021	0.8333	0.7376	0.7692	0.6667	0.6250
34	NU OTHER SOLID	2/ 7/15/ U/3/0	CLEAR	1.0204	1.1111	0.8772	0.8475	0.8621	0.7937	0.8065	0.7143	0.6849
35	NU OTHER SOLID	7/ 0/ 0/11/1/0	CLEAR	1.3514	0.9804	1.0204	1.0038	1.0204	0.9615	1.2500	1.0638	1.0204
36	NU OTHER SOLID	2/ 5/15/ U/3/0	CLEAR	1.0638	1.1111	0.9259	0.8259	0.8475	0.8475	0.8259	0.8197	0.7937
37	NU OTHER SOLID	2/ 9/15/ U/3/0	CLEAR	1.0870	1.0417	0.9259	0.872	0.8065	0.8197	0.8197	0.6944	0.6494
38	NU OTHER SOLID	2/10/14/ U/3/0	CLEAR	1.1364	1.0204	1.0617	0.9259	0.8454	0.8475	0.9091	0.7937	0.7553
39	NU OTHER SOLID	2/10/14/ U/3/0	CLEAR	1.1364	1.0204	1.0617	0.9259	0.8454	0.8475	0.9091	0.7937	0.7553
40	NU OTHER SOLID	2/10/14/ U/3/0	CLEAR	1.0870	1.0204	0.9091	0.8197	0.8333	0.7463	0.7692	0.6175	0.5682
41	NU OTHER SOLID	2/ 7/14/ U/3/0	CLEAR	1.0870	1.0204	0.8772	0.8197	0.7815	0.7463	0.7692	0.6175	0.5682

465	NU OTHER SOLID	2/ 4/15/ U/3/0	1.1564	0.9804	0.8621	0.8475	0.8553	0.8197	0.7576	0.5882	0.5747
466	NU OTHER SOLID	2/11/15/ U/3/0	0.9091	0.8929	0.8475	0.7692	0.7145	0.7246	0.6250	0.4854	0.5597
475	NU OTHER SOLID	2/12/14/ U/3/0	0.9091	0.9091	0.9091	0.8333	0.7937	0.7692	0.7145	0.6849	0.5519
479	NU OTHER SOLID	2/ 5/14/ U/3/0	1.0658	1.0658	0.8621	0.8197	0.7145	0.6849	0.5519	0.4202	0.5289
481	NU OTHER SOLID	2/ 9/14/ U/3/0	1.1028	1.1364	1.0000	0.9091	0.8621	0.8475	0.8065	0.7463	0.6757
484	NU OTHER SOLID	2/ 9/14/ U/3/0	1.2195	1.0000	1.0000	0.9434	0.9091	0.8772	0.8475	0.8065	0.7145
490	NU OTHER SOLID	2/10/14/ U/3/0	0.9804	1.0000	0.9615	0.8197	0.7463	0.8475	0.7813	0.7145	0.6410
496	NU OTHER SOLID	2/ 4/10/ U/3/0	1.2195	1.0417	0.8929	0.9615	0.9091	0.8929	0.8553	0.8065	0.7813
499	NU OTHER SOLID	2/ 1/14/ U/3/0	1.1111	1.0204	0.9434	0.8333	0.8333	0.8197	0.7813	0.7463	0.6410
501	NU OTHER SOLID	2/11/14/ U/3/0	1.3158	1.0658	1.0417	0.9804	0.8772	0.8333	0.7813	0.7463	0.6757
504	NU OTHER SOLID	2/ 1/14/ U/3/0	1.1111	1.0204	1.0000	0.9091	0.8621	0.8299	0.8065	0.7813	0.7463
511	NU OTHER SOLID	2/13/12/ U/3/0	1.1628	1.0000	0.9615	0.9259	0.8333	0.8621	0.8197	0.7813	0.6667
519	NU OTHER SOLID	2/ 8/14/ U/3/0	1.1564	1.0870	0.9804	0.8929	0.8772	0.8299	0.8065	0.7813	0.7576
524	NU OTHER SOLID	2/ 9/14/ U/3/0	1.1111	1.0658	0.8475	0.7555	0.6494	0.5814	0.4762	0.3731	0.3165
526	NU OTHER SOLID	2/ 1/14/ U/3/0	1.1028	1.0204	1.0000	0.8772	0.8621	0.8475	0.8299	0.8065	0.7813
529	NU OTHER SOLID	2/10/14/ U/3/0	0.9615	1.0870	1.0204	0.9259	0.7937	0.7555	0.7246	0.6529	0.5814
545	NU OTHER SOLID	2/ 5/10/ U/3/0	1.1564	0.8621	0.8333	0.7737	0.6667	0.5495	0.4152	0.2959	0.2564
547	NU OTHER SOLID	2/ 5/15/ U/3/0	1.1028	1.0204	0.9259	0.8621	0.8065	0.8065	0.7246	0.6529	0.5814
550	NU OTHER SOLID	2/ 2/15/ U/3/0	1.0658	1.0204	0.9804	0.9091	0.8197	0.8772	0.7937	0.7463	0.6849
555	NU OTHER SOLID	2/ 2/15/ U/3/0	1.2195	1.0658	0.9434	0.8772	0.8065	0.7937	0.7463	0.7042	0.6410
557	NU OTHER SOLID	2/ 5/14/ U/3/0	1.1111	0.9804	1.0000	0.9091	0.8475	0.8621	0.8197	0.7813	0.7042
560	NU OTHER SOLID	2/ 1/14/ U/3/0	1.0370	1.0000	0.8772	0.8475	0.8333	0.8553	0.7937	0.7463	0.6944
561	NU OTHER SOLID	2/15/14/ U/3/0	1.2521	1.0417	0.8929	0.8475	0.7434	0.7576	0.6576	0.6377	0.5952
568	NU OTHER SOLID	2/ 1/14/ U/3/0	1.1628	1.0658	0.9615	0.8772	0.8475	0.8553	0.7813	0.7463	0.6944
574	NU OTHER SOLID	6/ 6/14/ U/3/0	1.1111	1.0000	0.9259	0.8621	0.8333	0.8197	0.8197	0.7813	0.6757
585	NU OTHER SOLID	2/ 5/14/ U/3/0	1.1028	1.0417	0.9434	0.9615	0.8621	0.8772	0.8197	0.7813	0.6579
586	NU OTHER SOLID	2/ 2/14/ U/3/0	1.0658	1.0204	0.9259	0.9091	0.8621	0.8553	0.7813	0.7463	0.6944
588	NU OTHER SOLID	2/ 4/14/ U/3/0	0.9615	0.9259	0.8667	0.8475	0.8065	0.8065	0.7576	0.7042	0.6410
596	NU OTHER SOLID	2/ 4/14/ U/3/0	1.0870	1.1111	1.0000	0.8475	0.8065	0.8475	0.8197	0.7813	0.7042
598	NU OTHER SOLID	5/18/ 11/31/3/0	1.0870	1.0870	1.0000	0.8621	0.8772	0.8621	0.8553	0.8197	0.7246
607	NU OTHER SOLID	2/ 1/15/ U/3/0	1.0204	0.9804	0.9091	0.8772	0.8475	0.8475	0.7937	0.7463	0.6667
609	NU OTHER SOLID	2/ 1/14/ U/3/0	1.1111	1.0204	1.0204	0.9615	0.9615	0.8929	0.8772	0.8553	0.7692
634	NU OTHER SOLID	2/ 6/14/ U/3/0	1.1028	1.0658	0.9259	0.8621	0.8475	0.8772	0.8553	0.8065	0.7692
636	NU OTHER SOLID	2/ 5/14/ U/3/0	1.0658	0.9615	0.9259	0.8065	0.8475	0.8772	0.8553	0.8065	0.7692
640	NU OTHER SOLID	5/18/ 11/31/3/0	1.2195	1.0417	1.0000	0.8621	0.8929	0.8621	0.8553	0.8197	0.7246
645	NU OTHER SOLID	2/ 1/15/ U/3/0	1.0658	1.0417	0.9091	0.8065	0.8475	0.8621	0.8553	0.8065	0.7692
659	NU OTHER SOLID	2/ 1/15/ U/3/0	1.0658	1.0000	0.9434	0.8929	0.8929	0.8621	0.8553	0.8065	0.7692
662	NU OTHER SOLID	2/ 1/15/ U/3/0	1.0638	0.8772	0.8475	0.7937	0.7353	0.7042	0.6576	0.6259	0.5952
665	NU OTHER SOLID	2/ 9/12/ U/3/0	1.0658	1.0000	0.9259	0.8621	0.8065	0.7553	0.7576	0.7145	0.6410
680	NU OTHER SOLID	2/ 4/14/ U/3/0	1.0204	1.1111	1.0417	0.9434	0.9615	0.8929	0.8065	0.8929	0.8475
682	NU OTHER SOLID	2/ 1/14/ U/3/0	1.1628	1.0417	0.9434	0.9091	0.8621	0.8553	0.7813	0.7463	0.6529
685	NU OTHER SOLID	2/ 1/14/ U/3/0	1.0870	0.9804	0.9091	0.7692	0.6944	0.6529	0.6494	0.6197	0.5968
692	NU OTHER SOLID	2/ 1/15/ U/3/0	1.1628	0.9804	0.8929	0.8475	0.8065	0.8494	0.8197	0.7813	0.7145
705	NU OTHER SOLID	2/ 5/12/ U/3/0	1.0204	1.0000	0.8621	0.7376	0.6667	0.6494	0.5326	0.4332	0.3165
706	NU OTHER SOLID	2/ 5/15/ U/3/0	1.0204	0.9434	0.9091	0.8065	0.8621	0.8494	0.8197	0.7813	0.7042
709	NU OTHER SOLID	2/ 12/14/ U/3/0	1.2195	1.0658	1.0000	0.8772	0.8494	0.8197	0.7813	0.7463	0.6944
712	NU OTHER SOLID	2/ 1/15/ U/3/0	1.1111	1.0417	0.9259	0.8333	0.8333	0.8299	0.7937	0.7692	0.7145
716	NU OTHER SOLID	2/ 1/15/ U/3/0	1.0870	1.0000	0.9434	0.8929	0.8929	0.8929	0.8553	0.8065	0.7692
720	NU OTHER SOLID	2/ 1/14/ U/3/0	1.1564	1.0658	0.9434	0.8475	0.9091	0.8772	0.8065	0.7576	0.7246
725	NU OTHER SOLID	2/ 1/14/ U/3/0	1.0570	1.0870	0.9434	0.8065	0.7463	0.6849	0.6098	0.5265	0.4545
731	NU OTHER SOLID	2/ 1/14/ U/3/0	1.2195	1.0204	0.9615	0.8929	0.8333	0.8772	0.8197	0.7692	0.7145
732	NU OTHER SOLID	2/ 1/14/ U/3/0	1.0417	0.9804	0.8475	0.8197	0.7246	0.7937	0.7353	0.6579	0.5618
736	NU OTHER SOLID	2/ 1/15/ U/3/0	1.1564	1.0658	0.9434	0.8929	0.8333	0.8621	0.8197	0.7813	0.7042
739	NU OTHER SOLID	2/11/14/ U/3/0	1.0000	1.0000	0.8772	0.8475	0.7145	0.6529	0.5203	0.4310	0.3472
741	NU OTHER SOLID	2/ 1/15/ U/3/0	1.1111	0.9615	0.8929	0.8772	0.8475	0.7937	0.7145	0.6944	0.6329
742	NU OTHER SOLID	2/ 9/14/ U/3/0	1.1564	0.9804	0.9091	0.8772	0.8475	0.7937	0.6757	0.6024	0.5102
749	NU OTHER SOLID	2/ 1/14/ U/3/0	1.1564	0.9804	0.9434	0.8772	0.7937	0.7692	0.6667	0.5747	0.5000
755	NU OTHER SOLID	2/15/15/ U/3/0	1.2509	1.0658	0.9259	0.8772	0.8333	0.8197	0.8197	0.8065	0.6944
759	NU OTHER SOLID	2/ 1/14/ U/3/0	1.1905	0.9615	0.9434	0.8475	0.7937	0.8065	0.7692	0.7463	0.6667
767	NU OTHER SOLID	2/ 1/14/ U/3/0	1.1905	0.9804	0.8929	0.8772	0.8475	0.8065	0.7463	0.7042	0.6329
774	NU OTHER SOLID	2/ 9/14/ U/3/0	1.0870	0.9804	0.8929	0.8772	0.8475	0.7813	0.6579	0.5452	0.4717
775	NU OTHER SOLID	2/ 9/14/ U/3/0	1.2509	0.9804	0.8929	0.8772	0.8475	0.8065	0.7463	0.7042	0.6259
778	NU OTHER SOLID	2/ 5/15/ U/3/0	1.1111	0.9615	0.9804	0.8929	0.8772	0.8475	0.7937	0.7463	0.6259
785	NU OTHER SOLID	2/ 9/10/ U/3/0	1.0870	0.9434	0.8197	0.7463	0.6667	0.6259	0.5495	0.4694	0.3805
789	NU OTHER SOLID	2/ 1/14/ U/3/0	1.1111	0.9434	0.8772	0.8475	0.7937	0.7813	0.7042	0.6494	0.5452
795	NU OTHER SOLID	5/18/ 11/31/3/0	1.1111	0.9434	0.8772	0.8475	0.7937	0.7813	0.7042	0.6494	0.5452

1005	NU OTHER SOLID	2/ 5/14/ 0/3/0	1.1720	1.0200	0.7015	0.7015	0.6944	0.6529	0.5747	0.5051
1010	NU OTHER SOLID	2/ 5/13/ 0/3/0	1.0000	0.9804	0.9021	0.9021	0.8576	0.8049	0.6494	0.5682
1011	NU OTHER SOLID	2/ 5/13/ 0/3/0	1.1625	0.9804	0.9615	0.9259	0.8929	0.8929	0.7813	0.7246
1020	NU OTHER SOLID	2/ 7/12/ 0/3/0	1.0204	1.0000	0.9454	0.9259	0.8621	0.8475	0.8475	0.7576
1025	NU OTHER SOLID	2/ 5/14/ 0/3/0	1.1405	1.0870	1.0000	0.8621	0.8475	0.8475	0.8197	0.8065
1030	NU OTHER SOLID	2/ 7/12/ 0/3/0	0.9454	0.8929	0.7015	0.6944	0.6529	0.6529	0.6494	0.5556
1034	NU OTHER SOLID	2/ 5/14/ 0/3/0	1.0638	1.0000	0.9259	0.8929	0.8929	0.8929	0.7692	0.6667
1040	NU OTHER SOLID	2/11/14/ 0/3/0	1.3758	1.1364	0.9259	0.9454	0.9021	0.8621	0.8065	0.7463
1042	NU OTHER SOLID	2/ 7/12/ 0/3/0	1.2195	0.9615	0.9454	0.8621	0.8475	0.8475	0.8065	0.7463
1047	NU OTHER SOLID	2/11/14/ 0/3/0	1.0204	1.0204	0.9804	0.9021	0.8576	0.8049	0.6494	0.5747
1051	NU OTHER SOLID	2/ 6/14/ 0/3/0	1.0417	1.0000	0.9259	0.8621	0.8475	0.8475	0.7576	0.6410
12	END UF 2 SOLIDS	2/ 7/14/ 0/3/0	1.0638	1.0000	0.8621	0.8475	0.8475	0.8475	0.7576	0.6410
24	END UF 2 SOLIDS	2/ 7/14/ 0/3/0	1.1111	1.1111	0.8621	0.8475	0.8475	0.8475	0.7576	0.6410
31	END UF 2 SOLIDS	2/11/14/ 0/3/0	1.1028	1.1111	0.9259	0.8621	0.8475	0.8475	0.7576	0.6410
33	END UF 2 SOLIDS	2/ 7/14/ 0/3/0	1.1111	1.1111	0.9259	0.8621	0.8475	0.8475	0.7576	0.6410
39	END UF 2 SOLIDS	2/ 7/14/ 0/3/0	1.1111	1.1111	0.9259	0.8621	0.8475	0.8475	0.7576	0.6410
62	END UF 2 SOLIDS	2/ 7/13/ 0/3/0	1.0204	1.0638	0.8621	0.8475	0.8475	0.8475	0.7576	0.6410
64	END UF 2 SOLIDS	2/ 7/13/ 0/3/0	1.0870	1.0870	0.9259	0.8621	0.8475	0.8475	0.7576	0.6410
65	END UF 2 SOLIDS	2/11/13/ 0/3/0	1.1111	1.1628	0.8621	0.8475	0.8475	0.8475	0.7576	0.6410
70	END UF 2 SOLIDS	2/ 5/13/ 0/3/0	1.0370	1.1364	0.9021	0.8621	0.8475	0.8475	0.7576	0.6410
86	END UF 2 SOLIDS	2/ 7/13/ 0/3/0	0.9804	1.0417	0.8621	0.8475	0.8475	0.8475	0.7576	0.6410
91	END UF 2 SOLIDS	2/ 7/13/ 0/3/0	1.0638	1.0870	0.9021	0.8621	0.8475	0.8475	0.7576	0.6410
102	END UF 2 SOLIDS	2/12/13/ 0/3/0	1.1111	1.1111	0.8621	0.8475	0.8475	0.8475	0.7576	0.6410
106	END UF 2 SOLIDS	2/ 5/12/ 0/3/0	1.0370	1.1111	0.8621	0.8475	0.8475	0.8475	0.7576	0.6410
112	END UF 2 SOLIDS	2/11/12/ 0/4/0	0.9804	1.0000	0.8621	0.8475	0.8475	0.8475	0.7576	0.6410
121	END UF 2 SOLIDS	2/11/12/ 0/3/0	1.0638	1.0870	0.8621	0.8475	0.8475	0.8475	0.7576	0.6410
132	END UF 2 SOLIDS	2/ 5/14/ 0/3/0	1.0000	0.8772	0.8621	0.8475	0.8475	0.8475	0.7576	0.6410
162	END UF 2 SOLIDS	2/11/13/ 0/3/0	1.0417	1.0000	0.8621	0.8475	0.8475	0.8475	0.7576	0.6410
182	END UF 2 SOLIDS	2/ 6/14/ 0/3/0	1.0417	1.0870	0.8621	0.8475	0.8475	0.8475	0.7576	0.6410
172	END UF 2 SOLIDS	2/ 7/13/ 0/3/0	0.9021	1.0000	0.8621	0.8475	0.8475	0.8475	0.7576	0.6410
177	END UF 2 SOLIDS	0/ 4/ 0/ 0/3/0	1.0000	1.0000	0.8621	0.8475	0.8475	0.8475	0.7576	0.6410
180	END UF 2 SOLIDS	0/ 4/ 0/ 0/3/0	1.0000	1.0638	0.8621	0.8475	0.8475	0.8475	0.7576	0.6410
190	END UF 2 SOLIDS	3/19/ 0/33/3/0	1.0638	1.0638	0.8621	0.8475	0.8475	0.8475	0.7576	0.6410
198	END UF 2 SOLIDS	2/ 7/13/ 0/3/0	1.0638	1.0638	0.8621	0.8475	0.8475	0.8475	0.7576	0.6410
200	END UF 2 SOLIDS	2/ 6/14/ 0/3/0	1.0638	1.1111	0.8621	0.8475	0.8475	0.8475	0.7576	0.6410
207	END UF 2 SOLIDS	3/17/ 0/33/3/0	1.0204	1.1111	0.8621	0.8475	0.8475	0.8475	0.7576	0.6410
223	END UF 2 SOLIDS	2/ 6/14/ 0/3/0	1.1111	1.1628	0.8621	0.8475	0.8475	0.8475	0.7576	0.6410
232	END UF 2 SOLIDS	2/ 4/12/ 0/3/0	1.1111	1.0870	0.8621	0.8475	0.8475	0.8475	0.7576	0.6410
236	END UF 2 SOLIDS	2/ 4/12/ 0/3/0	1.1111	1.0870	0.8621	0.8475	0.8475	0.8475	0.7576	0.6410
239	END UF 2 SOLIDS	2/ 4/12/ 0/3/0	1.1111	1.1364	0.8621	0.8475	0.8475	0.8475	0.7576	0.6410
249	END UF 2 SOLIDS	2/ 5/13/ 0/3/0	1.1111	1.1364	0.8621	0.8475	0.8475	0.8475	0.7576	0.6410
254	END UF 2 SOLIDS	2/11/12/ 0/3/0	1.1111	1.2195	0.8621	0.8475	0.8475	0.8475	0.7576	0.6410
258	END UF 2 SOLIDS	2/ 5/13/ 0/3/0	1.0638	1.0638	0.8621	0.8475	0.8475	0.8475	0.7576	0.6410
270	END UF 2 SOLIDS	2/11/14/ 0/3/0	1.0638	1.0638	0.8621	0.8475	0.8475	0.8475	0.7576	0.6410
304	END UF 2 SOLIDS	2/12/14/ 0/3/0	1.2500	1.1905	0.8621	0.8475	0.8475	0.8475	0.7576	0.6410
333	END UF 2 SOLIDS	2/12/14/ 0/3/0	1.0638	1.0204	0.8621	0.8475	0.8475	0.8475	0.7576	0.6410
340	END UF 2 SOLIDS	2/ 5/14/ 0/3/0	1.1364	1.0870	0.8621	0.8475	0.8475	0.8475	0.7576	0.6410
363	END UF 2 SOLIDS	2/ 7/10/ 0/3/0	1.0204	0.9804	0.8621	0.8475	0.8475	0.8475	0.7576	0.6410
364	END UF 2 SOLIDS	2/ 7/10/ 0/3/0	1.1111	1.1111	0.8621	0.8475	0.8475	0.8475	0.7576	0.6410
366	END UF 2 SOLIDS	2/ 7/12/ 0/3/0	1.1111	1.1111	0.8621	0.8475	0.8475	0.8475	0.7576	0.6410
368	END UF 2 SOLIDS	2/ 5/13/ 0/3/0	1.2500	1.1364	0.8621	0.8475	0.8475	0.8475	0.7576	0.6410
383	END UF 2 SOLIDS	2/ 7/14/ 0/3/0	1.2195	1.0638	0.8621	0.8475	0.8475	0.8475	0.7576	0.6410
385	END UF 2 SOLIDS	2/ 7/14/ 0/3/0	1.0638	0.8929	0.8621	0.8475	0.8475	0.8475	0.7576	0.6410
407	END UF 2 SOLIDS	2/ 7/14/ 0/3/0	1.0638	0.8929	0.8621	0.8475	0.8475	0.8475	0.7576	0.6410
422	END UF 2 SOLIDS	2/ 7/12/ 0/3/0	1.0870	0.7813	0.8621	0.8475	0.8475	0.8475	0.7576	0.6410
430	END UF 2 SOLIDS	2/ 7/14/ 0/3/0	1.0638	0.9454	0.8621	0.8475	0.8475	0.8475	0.7576	0.6410
443	END UF 2 SOLIDS	1/ 5/ 0/ 1/2/0	1.1628	1.1364	0.8621	0.8475	0.8475	0.8475	0.7576	0.6410
506	END UF 2 SOLIDS	2/ 5/14/ 0/3/0	1.1628	0.9454	0.8621	0.8475	0.8475	0.8475	0.7576	0.6410
545	END UF 2 SOLIDS	2/ 7/10/ 0/3/0	1.0417	0.8772	0.8621	0.8475	0.8475	0.8475	0.7576	0.6410
575	END UF 2 SOLIDS	2/ 7/13/ 0/3/0	1.0870	1.0870	0.8621	0.8475	0.8475	0.8475	0.7576	0.6410
607	END UF 2 SOLIDS	2/ 4/14/ 0/3/0	1.1364	1.0417	0.8621	0.8475	0.8475	0.8475	0.7576	0.6410
605	END UF 2 SOLIDS	2/ 4/14/ 0/3/0	1.1364	1.0000	0.8621	0.8475	0.8475	0.8475	0.7576	0.6410
604	END UF 2 SOLIDS	2/ 3/13/ 0/3/0	1.1364	0.9615	0.8621	0.8475	0.8475	0.8475	0.7576	0.6410
612	END UF 2 SOLIDS	2/ 5/14/ 0/3/0	1.0870	0.9454	0.8621	0.8475	0.8475	0.8475	0.7576	0.6410
647	END UF 2 SOLIDS	2/ 5/14/ 0/3/0	1.2500	1.1111	0.8621	0.8475	0.8475	0.8475	0.7576	0.6410
720	END UF 2 SOLIDS	2/ 5/14/ 0/3/0	1.1364	1.0638	0.8621	0.8475	0.8475	0.8475	0.7576	0.6410

730	2ND	UF	2	SOLIDS	2/ 5/14/	U/3/0	CLEAR	1.1111	0.9259	0.7815	0.6410	0.5435	0.5000	0.4404	0.5350	0.3086
731	2ND	UF	2	SOLIDS	2/ 5/15/	U/3/0	CLEAR	1.0633	0.9259	0.8005	0.6579	0.4425	0.5012	0.1742	0.1484	0.1558
732	2ND	UF	2	SOLIDS	2/11/14/	U/3/0	CLEAR	1.1025	1.0204	0.9804	0.8434	0.8772	0.8065	0.7937	0.7463	0.7143
761	2ND	UF	2	SOLIDS	2/ 7/12/	U/3/0	CLEAR	1.0870	1.0417	0.9091	0.8772	0.8065	0.8772	0.8772	0.7463	0.7246
760	2ND	UF	2	SOLIDS	2/ 7/14/	U/3/0	CLEAR	1.0870	1.0204	0.9091	0.8475	0.8475	0.8197	0.8197	0.6494	0.5682
801	2ND	UF	2	SOLIDS	2/ 7/16/	U/3/0	CLEAR	1.0638	0.9454	0.8021	0.6475	0.6475	0.6021	0.5814	0.4052	0.2890
817	2ND	UF	2	SOLIDS	2/ 5/14/	U/3/0	CLEAR	1.1025	1.0417	0.8929	0.8929	0.8333	0.7576	0.7042	0.6024	0.5263
844	2ND	UF	2	SOLIDS	2/13/14/	U/3/0	CLEAR	1.1005	0.9615	0.8065	0.7246	0.5922	0.5618	0.4425	0.3185	0.2174
893	2ND	UF	2	SOLIDS	2/ 5/14/	U/3/0	CLEAR	1.1628	0.8929	0.8772	0.8197	0.7937	0.7553	0.6329	0.5122	0.3571
895	2ND	UF	2	SOLIDS	2/ 5/14/	U/3/0	CLEAR	0.8004	0.9615	0.8065	0.6944	0.6098	0.5435	0.4425	0.3472	0.2703
949	2ND	UF	2	SOLIDS	2/ 7/12/	U/3/0	CLEAR	0.9804	0.9615	0.8555	0.7576	0.6175	0.5814	0.4510	0.3247	0.2174
970	2ND	UF	2	SOLIDS	2/ 7/14/	U/3/0	CLEAR	1.0638	1.0204	0.9091	0.7465	0.7143	0.6579	0.5526	0.4854	0.3876
1000	2ND	UF	2	SOLIDS	2/ 7/14/	U/3/0	CLEAR	1.0000	0.9091	0.8555	0.8197	0.7576	0.7463	0.6098	0.5269	0.4101
34	3RD	UF	3	SOLIDS	2/11/14/	U/3/0	CLEAR	0.9454	1.0671	0.8929	0.8929	0.8621	0.8065	0.7463	0.6175	0.5495
44	3RD	UF	3	SOLIDS	2/ 5/14/	U/3/0	CLEAR	0.9804	0.9615	0.8475	0.8197	0.7576	0.7042	0.6024	0.5269	0.4101
81	3RD	UF	3	SOLIDS	2/ 5/14/	U/3/0	CLEAR	0.9804	0.9615	0.8475	0.8197	0.7576	0.7042	0.6024	0.5269	0.4101
94	3RD	UF	3	SOLIDS	2/11/12/	U/3/0	CLEAR	1.1111	1.0638	0.9091	0.8929	0.8065	0.7463	0.6098	0.5269	0.4101
129	3RD	UF	3	SOLIDS	2/13/14/	U/3/0	CLEAR	1.1025	1.1304	0.9259	0.8475	0.7692	0.6944	0.6175	0.5495	0.4335
149	3RD	UF	3	SOLIDS	1/ 5/ 11/14/	U/3/0	CLEAR	1.1111	1.1628	0.9454	0.8929	0.8772	0.8065	0.7463	0.6175	0.5495
160	3RD	UF	3	SOLIDS	2/ 7/14/	U/3/0	CLEAR	1.0671	1.0870	0.8929	0.8621	0.8197	0.7692	0.6667	0.5814	0.4694
220	3RD	UF	3	SOLIDS	3/17/ 11/32/4/0	U/3/0	CLEAR	1.1628	0.9091	0.8555	0.8197	0.7576	0.7042	0.6024	0.5269	0.4101
230	3RD	UF	3	SOLIDS	2/ 4/12/	U/3/0	CLEAR	1.0870	1.1628	0.8621	0.8333	0.7692	0.6944	0.6175	0.5495	0.4335
267	3RD	UF	3	SOLIDS	2/ 7/14/	U/3/0	CLEAR	1.1504	1.0417	0.8772	0.8475	0.8065	0.7463	0.6175	0.5495	0.4335
310	3RD	UF	3	SOLIDS	2/ 7/14/	U/3/0	CLEAR	1.1564	1.1304	0.9259	0.8929	0.8197	0.7463	0.6667	0.5814	0.4694
390	3RD	UF	3	SOLIDS	2/ 9/12/	U/3/0	CLEAR	1.2500	0.9615	0.8475	0.8197	0.7576	0.7042	0.6024	0.5269	0.4101
471	3RD	UF	3	SOLIDS	1/ 7/ 4/ 1/2/0	U/3/0	CLEAR	1.1564	1.0870	0.9454	0.8929	0.8772	0.8065	0.7463	0.6175	0.5495
567	3RD	UF	3	SOLIDS	3/17/ 11/32/0/0	U/3/0	CLEAR	1.0870	1.0204	0.8772	0.8475	0.8065	0.7463	0.6175	0.5495	0.4335
582	3RD	UF	3	SOLIDS	2/11/14/	U/3/0	CLEAR	1.2195	0.9259	0.8475	0.8197	0.7576	0.7042	0.6024	0.5269	0.4101
689	3RD	UF	3	SOLIDS	2/ 7/14/	U/3/0	CLEAR	2.2000	1.0251	1.1025	0.8475	0.8065	0.7463	0.6175	0.5495	0.4335
713	3RD	UF	3	SOLIDS	1/ 5/ 11/14/	U/3/0	CLEAR	1.1025	0.9615	0.8475	0.8197	0.7576	0.7042	0.6024	0.5269	0.4101
751	3RD	UF	3	SOLIDS	2/ 9/14/	U/3/0	CLEAR	1.0204	0.9615	0.8475	0.8197	0.7576	0.7042	0.6024	0.5269	0.4101
765	3RD	UF	3	SOLIDS	2/ 9/16/	U/3/0	CLEAR	1.0204	0.9615	0.8475	0.8197	0.7576	0.7042	0.6024	0.5269	0.4101
677	3RD	UF	3	SOLIDS	2/ 5/14/	U/3/0	CLEAR	1.0417	0.9615	0.8475	0.8197	0.7576	0.7042	0.6024	0.5269	0.4101
690	3RD	UF	3	SOLIDS	2/ 5/14/	U/3/0	CLEAR	1.0000	0.8621	0.8475	0.8333	0.7692	0.6944	0.6175	0.5495	0.4335
900	3RD	UF	3	SOLIDS	2/ 5/14/	U/3/0	CLEAR	1.0500	1.0204	0.9259	0.8475	0.8065	0.7463	0.6175	0.5495	0.4335
957	3RD	UF	3	SOLIDS	2/11/14/	U/3/0	CLEAR	1.0870	0.9615	0.8475	0.8197	0.7576	0.7042	0.6024	0.5269	0.4101
1000	3RD	UF	3	SOLIDS	2/ 9/14/	U/3/0	CLEAR	1.0417	1.0000	0.9454	0.8929	0.8772	0.8065	0.7463	0.6175	0.5495
1014	3RD	UF	3	SOLIDS	2/ 5/14/	U/3/0	CLEAR	1.0671	0.9259	0.8475	0.8197	0.7576	0.7042	0.6024	0.5269	0.4101
33	4TH	UF	4	SOLIDS	2/13/12/	U/3/0	10.500	1.1504	1.0000	0.9454	0.8929	0.8772	0.8065	0.7463	0.6175	0.5495
82	4TH	UF	4	SOLIDS	2/ 4/12/	U/3/0	CLEAR	1.0417	0.9454	0.8250	0.854	0.854	0.854	0.854	0.854	0.854
204	4TH	UF	4	SOLIDS	2/ 5/13/	U/3/0	CLEAR	1.0000	1.0870	0.9621	0.8333	0.7813	0.7143	0.6250	0.5376	0.4244
379	4TH	UF	4	SOLIDS	2/ 7/10/	U/3/0	7.150	1.1564	0.9615	0.8715	0.8065	0.7463	0.6667	0.5814	0.4664	0.3401
505	4TH	UF	4	SOLIDS	2/ 5/14/	U/3/0	CLEAR	1.1111	1.0204	0.8929	0.8621	0.8065	0.7463	0.6175	0.5495	0.4335
515	4TH	UF	4	SOLIDS	2/11/14/	U/3/0	CLEAR	1.1025	1.0417	0.8475	0.8197	0.7576	0.7042	0.6024	0.5269	0.4101
522	4TH	UF	4	SOLIDS	2/ 7/14/	U/3/0	CLEAR	1.1111	0.9615	0.8475	0.8197	0.7576	0.7042	0.6024	0.5269	0.4101
695	4TH	UF	4	SOLIDS	2/ 7/14/	U/3/0	CLEAR	1.0638	0.9454	0.8555	0.8475	0.8621	0.8621	0.8621	0.8621	0.8621
697	4TH	UF	4	SOLIDS	2/ 5/10/	U/3/0	5.150	0.8024	0.845	0.8000	0.8000	0.8000	0.8000	0.8000	0.8000	0.8000
709	4TH	UF	4	SOLIDS	1/ 4/ 6/ 1/2/0	U/3/0	CLEAR	1.1111	1.1111	0.9454	0.8475	0.7937	0.6475	0.5000	0.4167	0.2959
854	4TH	UF	4	SOLIDS	2/11/14/	U/3/0	CLEAR	1.1564	1.0000	0.8772	0.8197	0.7692	0.6944	0.6175	0.5495	0.4335
892	4TH	UF	4	SOLIDS	2/13/14/	U/3/0	CLEAR	1.0417	0.8772	0.7465	0.7553	0.8621	0.8621	0.8621	0.8621	0.8621
970	4TH	UF	4	SOLIDS	1/ 5/ 1/ 2/ 1/2/0	U/3/0	6.875	0.9454	0.8454	0.8454	0.8454	0.8454	0.8454	0.8454	0.8454	0.8454
297	5TH	UF	5	SOLIDS	2/ 9/14/	U/3/0	CLEAR	1.0870	1.0870	0.8621	0.8065	0.7692	0.6667	0.5814	0.4167	0.2959
359	5TH	UF	5	SOLIDS	2/ 9/14/	U/3/0	CLEAR	1.1025	1.0204	0.8772	0.8197	0.7692	0.6944	0.6175	0.5495	0.4335
791	5TH	UF	5	SOLIDS	2/13/14/	U/3/0	CLEAR	1.0638	0.9804	0.8621	0.8621	0.8621	0.8621	0.8621	0.8621	0.8621
879	5TH	UF	5	SOLIDS	2/ 5/14/	U/3/0	CLEAR	1.1564	1.0417	0.8929	0.8621	0.8065	0.7463	0.6175	0.5495	0.4335
962	5TH	UF	5	SOLIDS	2/12/12/	U/3/0	9.955	1.0870	1.0417	0.8621	0.8065	0.7463	0.6175	0.5495	0.4335	0.3289
935	6TH	UF	6	SOLIDS	2/15/13/	U/3/0	10.510	1.0870	0.8929	0.8621	0.8065	0.7463	0.6175	0.5495	0.4335	0.3289
952	7TH	UF	7	SOLIDS	2/10/12/	U/3/0	4.130	1.1564	0.9615	0.8621	0.8065	0.7463	0.6175	0.5495	0.4335	0.3289

2,4000 TU 2,5000

COMPUTER CHECK NO. 1125

APPENDIX III

A3 DATABANK OF INSTALLED SYSTEM SOLID TRANSPORT MEASUREMENTS.

69	NO OTHER SOLID	2/ 4/16/ 0/3/0	10.260	0.9804	0.8333	0.3937	0.2941	0.1338	0.2174	0.2008	0.0000	0.0000
71	NO OTHER SOLID	2/12/14/ 0/3/0	CLEAR	1.0638	1.0870	0.9259	0.7813	0.7692	0.7353	0.7266	0.6250	0.5618
72	NO OTHER SOLID	2/ 7/14/ 0/3/0	CLEAR	1.0638	1.1905	0.9615	0.9091	0.9615	0.8475	0.8621	0.7937	0.7463
74	NO OTHER SOLID	1/ 0/ 0/23/1/0	CLEAR	1.1364	1.1628	0.8475	1.0417	0.9804	1.0000	0.7813	0.8621	0.7937
78	NO OTHER SOLID	2/ 9/14/ 0/3/0	CLEAR	1.0417	1.1905	0.9259	0.8065	0.7576	0.7576	0.7937	0.6757	0.5882
87	NO OTHER SOLID	2/ 4/15/ 0/3/0	10.340	1.0417	1.1111	0.8065	0.6667	0.5376	0.3601	0.1266	0.0000	0.0000
92	NO OTHER SOLID	2/ 5/13/ 0/3/0	CLEAR	1.0870	1.1905	1.0000	0.8772	0.8333	0.8197	0.7813	0.6579	0.5952
93	NO OTHER SOLID	2/12/15/ 0/3/0	CLEAR	1.0000	1.0000	0.8621	0.7692	0.7463	0.6667	0.7353	0.6024	0.5435
103	NO OTHER SOLID	2/ 9/15/ 0/3/0	CLEAR	1.0417	1.1628	0.9615	0.8197	0.8475	0.8475	0.8333	0.6757	0.6410
104	NO OTHER SOLID	2/11/15/ 0/3/0	CLEAR	1.0638	1.0870	0.9091	0.9434	0.8929	0.8333	0.9091	0.7813	0.7042
111	NO OTHER SOLID	2/10/14/ 0/3/0	CLEAR	1.0870	1.0204	0.8621	0.7463	0.7042	0.6757	0.6024	0.3906	0.2666
118	NO OTHER SOLID	2/13/15/ 0/3/0	CLEAR	1.1364	1.1111	0.8621	0.8621	0.8333	0.7576	0.7692	0.6667	0.6250
120	NO OTHER SOLID	2/ 7/15/ 0/3/0	CLEAR	1.0204	1.1111	0.8772	0.8475	0.8621	0.7937	0.8065	0.7143	0.6849
122	NO OTHER SOLID	1/ 0/ 0/11/1/0	CLEAR	1.3514	0.9804	1.0204	1.0638	1.0204	0.9615	1.2500	1.0638	1.0204
123	NO OTHER SOLID	2/ 5/15/ 0/3/0	CLEAR	1.0638	1.1111	0.9259	0.9259	0.8475	0.8475	0.9259	0.8197	0.7937
124	NO OTHER SOLID	2/ 9/15/ 0/3/0	CLEAR	1.0870	1.0417	0.9259	0.8772	0.8065	0.8197	0.8197	0.6944	0.6494
127	NO OTHER SOLID	2/10/14/ 0/3/0	CLEAR	1.1364	1.0204	1.0417	0.9259	0.9434	0.8475	0.9091	0.7937	0.7353
131	NO OTHER SOLID	2/10/15/ 0/3/0	CLEAR	1.0870	1.0204	0.9091	0.8197	0.8333	0.7463	0.7692	0.6173	0.5682
133	NO OTHER SOLID	2/ 7/14/ 0/3/0	CLEAR	1.0870	1.0870	0.8772	0.8197	0.7813	0.7143	0.7143	0.5747	0.5208
140	NO OTHER SOLID	2/15/15/ 0/3/0	CLEAR	1.0870	0.9804	0.8197	0.7463	0.7266	0.6098	0.6673	0.3125	0.2166
141	NO OTHER SOLID	2/ 7/14/ 0/3/0	CLEAR	1.1111	1.0417	0.8929	0.8475	0.8197	0.7692	0.7463	0.6250	0.5556
145	NO OTHER SOLID	2/ 7/14/ 0/3/0	CLEAR	1.0204	1.1111	0.8929	0.9259	0.8475	0.8065	0.8333	0.7143	0.6757
151	NO OTHER SOLID	2/ 9/14/ 0/3/0	CLEAR	1.0638	1.0204	0.8772	0.8929	0.8475	0.8333	0.8772	0.8065	0.7266
153	NO OTHER SOLID	5/ 4/12/11/3/2	CLEAR	0.0000	0.0000	0.0000	0.0000	0.0000	0.0000	0.0000	0.0000	0.0000
160	NO OTHER SOLID	2/ 4/15/ 0/3/0	CLEAR	1.0204	1.1111	0.8772	0.8333	0.8065	0.7692	0.8333	0.6757	0.5952
170	NO OTHER SOLID	2/ 7/14/ 0/3/0	CLEAR	1.0204	0.9804	0.7937	0.6494	0.5556	0.6032	0.2336	0.1362	0.1167
183	NO OTHER SOLID	2/ 6/14/ 0/3/0	CLEAR	1.1111	1.1628	0.9804	0.8621	0.7813	0.7692	0.8621	0.7143	0.6610
187	NO OTHER SOLID	2/ 5/13/ 0/3/0	CLEAR	1.0000	1.0638	0.9091	0.7463	0.7937	0.7266	0.6869	0.6856	0.6386
190	NO OTHER SOLID	2/ 5/15/ 0/3/0	CLEAR	0.9804	1.0638	0.8333	0.8772	0.8475	0.7576	0.8333	0.6944	0.6098
192	NO OTHER SOLID	2/ 8/13/ 0/3/0	CLEAR	1.0204	1.0000	0.8333	0.7937	0.7692	0.7143	0.6494	0.5102	0.4625
193	NO OTHER SOLID	2/ 5/15/ 0/3/0	CLEAR	1.0204	1.0870	0.9434	0.8772	0.8772	0.8065	0.8197	0.7143	0.6494
195	NO OTHER SOLID	2/ 5/15/ 0/3/0	CLEAR	1.1111	1.0000	0.8621	0.8772	0.8929	0.8065	0.8065	0.7463	0.6379
203	NO OTHER SOLID	2/11/12/ 0/3/0	CLEAR	1.1364	1.0638	0.8929	0.9091	0.8621	0.8197	0.8333	0.7143	0.6757

208	NO OTHER SOLID	3/19/ 0/33/3/0	CLEAR	1.0417	1.0870	0.9434	0.7813	0.8065	0.7692	0.7463	0.6173	0.5635
212	NO OTHER SOLID	2/ 5/15/ 0/3/0	CLEAR	1.0417	1.0870	0.8929	0.8675	0.7692	0.6757	0.5814	0.4587	0.3697
215	NO OTHER SOLID	2/ 8/14/ 0/3/0	CLEAR	1.2821	1.1111	1.0000	0.8929	0.9636	0.8772	0.8929	0.8197	0.7163
215	NO OTHER SOLID	2/ 6/14/ 0/3/0	CLEAR	1.1111	1.0417	0.8772	0.7813	0.6869	0.6410	0.5814	0.4386	0.3289
216	NO OTHER SOLID	6/ 1/ 2/ 0/1/0	CLEAR	0.0000	0.0000	0.0000	0.0000	0.0000	0.0000	0.0000	0.0000	0.0000
217	NO OTHER SOLID	2/ 4/15/ 0/3/0	CLEAR	1.1111	1.1628	1.0000	0.9259	0.8621	0.8675	0.8929	0.7692	0.7246
218	NO OTHER SOLID	2/ 5/15/ 0/3/0	11.130	0.8621	0.9804	0.8675	0.8065	0.7246	0.5814	0.3623	0.2128	0.0000
219	NO OTHER SOLID	2/ 6/13/ 0/3/0	CLEAR	1.1111	1.0638	0.9091	0.8621	0.8621	0.8065	0.8197	0.7042	0.6667
220	NO OTHER SOLID	2/ 5/15/ 0/3/0	CLEAR	1.1364	1.0417	0.8197	0.7813	0.7692	0.7813	0.8197	0.6173	0.6098
224	NO OTHER SOLID	2/ 5/14/ 0/3/0	CLEAR	1.0204	1.0870	0.9259	0.8929	0.8197	0.8197	0.7692	0.6579	0.5952
231	NO OTHER SOLID	2/ 6/14/ 0/3/0	CLEAR	1.0417	1.1364	0.8929	0.8772	0.8333	0.7937	0.8621	0.7692	0.6964
241	NO OTHER SOLID	1/ 0/ 0/ 2/1/0	CLEAR	1.0638	1.0000	0.8197	0.7813	0.7813	0.6667	0.6869	0.5495	0.4717
243	NO OTHER SOLID	2/ 5/14/ 0/3/0	CLEAR	1.1111	1.2821	0.9434	0.8065	0.8197	0.7353	0.7246	0.5952	0.5051
247	NO OTHER SOLID	2/13/13/ 0/3/0	CLEAR	1.0638	1.0417	0.9259	0.8621	0.8621	0.8197	0.7937	0.6944	0.6329
251	NO OTHER SOLID	2/ 4/15/ 0/3/0	CLEAR	1.0204	1.0638	0.8772	0.7813	0.7463	0.6869	0.6757	0.5767	0.5263
264	NO OTHER SOLID	3/18/ 0/ 0/3/0	CLEAR	1.0870	1.1628	0.9091	0.8772	0.8772	0.8333	0.8929	0.7663	0.6964
270	NO OTHER SOLID	2/ 6/14/ 0/3/0	CLEAR	1.0870	1.1628	0.9259	0.8772	0.9091	0.7937	0.8475	0.7246	0.6329
272	NO OTHER SOLID	2/ 3/14/ 0/3/0	CLEAR	1.0204	1.0204	0.8772	0.7937	0.8065	0.7937	0.7463	0.6329	0.5814
284	NO OTHER SOLID	2/ 5/14/ 0/3/0	CLEAR	1.1111	1.1905	0.9434	0.8772	0.8333	0.8333	0.8675	0.7353	0.6757
287	NO OTHER SOLID	2/ 7/14/ 0/3/0	CLEAR	1.1111	1.1905	0.9434	0.8772	0.8772	0.8772	0.8929	0.7813	0.7576
294	NO OTHER SOLID	2/ 9/14/ 0/3/0	CLEAR	0.9615	0.9434	0.8675	0.8197	0.8475	0.6757	0.6610	0.5635	0.6386
295	NO OTHER SOLID	2/ 9/14/ 0/3/0	CLEAR	1.0638	1.0638	0.8621	0.7692	0.7692	0.6757	0.6694	0.5000	0.4098
300	NO OTHER SOLID	2/ 9/14/ 0/3/0	CLEAR	1.0638	1.0638	0.8929	0.8675	0.8065	0.7353	0.8065	0.6667	0.5814
308	NO OTHER SOLID	2/ 9/14/ 0/3/0	CLEAR	1.0204	1.0638	0.8929	0.8675	0.8197	0.7376	0.7813	0.6173	0.5319
312	NO OTHER SOLID	2/12/14/ 0/3/0	CLEAR	1.1364	1.1111	0.9434	0.8333	0.8621	0.7937	0.7813	0.6944	0.5952
319	NO OTHER SOLID	2/ 7/14/ 0/3/0	CLEAR	1.1111	1.0870	0.9634	0.8929	0.8675	0.8621	0.8929	0.7576	0.7062
324	NO OTHER SOLID	2/ 9/14/ 0/3/0	CLEAR	1.0204	1.1628	0.7937	0.8929	0.8675	0.8333	0.7937	0.6610	0.6494
327	NO OTHER SOLID	2/11/14/ 0/3/0	CLEAR	1.1364	1.1111	0.9091	0.9091	0.8197	0.7813	0.8197	0.6944	0.5952
328	NO OTHER SOLID	2/ 6/14/ 0/3/0	CLEAR	1.0204	1.1364	0.9259	0.8772	0.9259	0.8675	0.8333	0.7663	0.7333
333	NO OTHER SOLID	5/11/14/ 0/3/4	CLEAR	1.1628	1.2500	0.8621	0.9434	0.8929	0.8621	0.9804	0.8333	0.7813
338	NO OTHER SOLID	2/12/14/ 0/3/0	CLEAR	1.0638	1.0000	0.9091	0.8929	0.8197	0.7813	0.7937	0.6610	0.5882
339	NO OTHER SOLID	2/ 9/14/ 0/3/0	CLEAR	1.0870	1.0417	0.8675	0.7937	0.7692	0.6964	0.5635	0.3706	0.3012
340	NO OTHER SOLID	2/11/14/ 0/3/0	CLEAR	1.0870	1.0638	0.9259	0.9259	0.8621	0.8621	0.8929	0.7463	0.6964

342	NO OTHER SOLID	2/ 7/14/ 0/3/0	CLEAR	1.1564	1.1111	0.8929	0.8621	0.8621	0.7937	0.7937	0.6757	0.6250
344	NO OTHER SOLID	2/ 5/14/ 0/3/0	CLEAR	1.1111	1.0417	0.8772	0.8772	0.9091	0.8621	0.8772	0.7813	0.7376
345	NO OTHER SOLID	2/ 7/15/ 0/3/0	CLEAR	1.1905	1.2195	0.9091	0.9091	0.8621	0.7937	0.7813	0.6757	0.6494
349	NO OTHER SOLID	2/11/14/ 0/3/0	CLEAR	1.0870	1.0417	0.9091	0.7937	0.7692	0.7163	0.6494	0.5319	0.6167
357	NO OTHER SOLID	2/ 5/14/ 0/3/0	CLEAR	1.2500	1.0870	0.8621	0.8929	0.9091	0.8675	0.8197	0.7576	0.7062
361	NO OTHER SOLID	2/ 7/14/ 0/3/0	CLEAR	1.1364	1.0417	0.9091	0.8675	0.8333	0.7937	0.7813	0.6667	0.5814
365	NO OTHER SOLID	2/ 9/14/ 0/3/0	CLEAR	1.0000	1.0417	0.8333	0.8065	0.7663	0.6173	0.5208	0.3145	0.1661
373	NO OTHER SOLID	2/ 7/14/ 0/3/0	CLEAR	1.1364	1.0870	0.8929	0.9091	0.7937	0.8475	0.8333	0.6667	0.6494
382	NO OTHER SOLID	2/ 7/15/ 0/3/0	CLEAR	1.2500	1.0638	0.9434	0.8333	0.7353	0.7937	0.7692	0.7163	0.6410
404	NO OTHER SOLID	2/15/14/ 0/3/0	CLEAR	1.1111	0.9615	0.8475	0.8197	0.7463	0.6757	0.5435	0.4132	0.3866
414	NO OTHER SOLID	3/ 8/ 0/55/4/0	CLEAR	1.0417	1.0638	0.8772	0.7937	0.6494	0.4950	0.3817	0.2185	0.1832
419	NO OTHER SOLID	2/ 7/14/ 0/3/0	CLEAR	1.1628	1.1111	1.0000	0.8621	0.8065	0.8333	0.7163	0.6173	0.5556
421	NO OTHER SOLID	2/ 7/12/ 0/3/0	CLEAR	1.2821	0.9615	0.8929	0.8929	0.8621	0.8621	0.8197	0.7937	0.7937
425	NO OTHER SOLID	2/11/14/ 0/3/0	CLEAR	1.1628	0.9615	0.8929	0.8333	0.8475	0.7692	0.7692	0.7266	0.6667
427	NO OTHER SOLID	2/ 7/14/ 0/3/0	CLEAR	1.0638	1.0204	0.9434	0.8475	0.8065	0.8675	0.7937	0.7576	0.7353
428	NO OTHER SOLID	2/11/15/ 0/3/0	CLEAR	1.1564	1.0417	0.9434	0.9091	0.8772	0.8475	0.8065	0.8065	0.7062
435	NO OTHER SOLID	2/11/15/ 0/3/0	CLEAR	1.1905	0.9615	0.9615	0.9434	0.8929	0.7937	0.7692	0.7042	0.6250
441	NO OTHER SOLID	2/10/15/ 0/3/0	CLEAR	1.0870	1.1111	0.9091	0.9091	0.7813	0.7692	0.7353	0.6250	0.5952
451	NO OTHER SOLID	2/ 4/16/ 0/3/0	CLEAR	0.8333	0.8929	0.5051	0.2326	0.1923	0.2577	0.2857	0.2427	0.2262
458	NO OTHER SOLID	2/ 4/15/ 0/5/0	CLEAR	0.0000	0.0000	0.0000	0.8772	0.9259	0.8772	1.0000	0.6944	0.7376
459	NO OTHER SOLID	2/ 7/15/ 0/3/0	CLEAR	1.1628	1.0870	0.8065	0.7692	0.7463	0.6944	0.5682	0.4132	0.3165
461	NO OTHER SOLID	2/11/15/ 0/3/0	CLEAR	1.1628	1.1111	0.8475	0.7937	0.9091	0.8333	0.7576	0.6250	0.6024
462	NO OTHER SOLID	2/ 4/13/ 0/3/0	CLEAR	1.1364	0.9804	0.8621	0.8475	0.8333	0.8197	0.7576	0.5882	0.5767
469	NO OTHER SOLID	2/11/15/ 0/3/0	CLEAR	0.9091	0.8929	0.8475	0.7692	0.7163	0.7266	0.6250	0.4854	0.3597
475	NO OTHER SOLID	2/12/14/ 0/3/0	CLEAR	1.1364	0.9091	0.9091	0.8333	0.7937	0.7692	0.7163	0.6849	0.5319
479	NO OTHER SOLID	2/ 5/14/ 0/5/0	CLEAR	1.1364	1.0638	0.8621	0.8197	0.7163	0.6849	0.5376	0.4202	0.3289
481	NO OTHER SOLID	2/ 9/14/ 0/3/0	CLEAR	1.1628	1.1364	1.0000	0.9091	0.8621	0.8675	0.8065	0.7663	0.6757
484	NO OTHER SOLID	2/ 9/14/ 0/3/0	CLEAR	1.2195	1.0000	1.0000	0.9434	0.9091	0.8772	0.8675	0.8065	0.7163
490	NO OTHER SOLID	2/10/14/ 0/3/0	CLEAR	0.9804	1.0000	0.9615	0.8197	0.7463	0.8675	0.7813	0.7163	0.6410
496	NO OTHER SOLID	2/ 4/16/ 0/3/0	CLEAR	1.2195	1.0417	0.8929	0.9615	0.9091	0.8929	0.8333	0.8065	0.7813
499	NO OTHER SOLID	2/ 7/14/ 0/3/0	CLEAR	1.1111	1.0204	0.9434	0.8333	0.8333	0.8197	0.7813	0.7266	0.6610
501	NO OTHER SOLID	2/11/14/ 0/3/0	CLEAR	1.3158	1.0638	1.0417	0.9804	0.8772	0.8333	0.7813	0.8333	0.7813
504	NO OTHER SOLID	2/ 7/14/ 0/3/0	CLEAR	1.1111	1.0204	1.0000	0.9091	0.8621	0.8929	0.8621	0.8333	0.7663

511	NO OTHER SOLID	2/13/12/ 0/3/0	CLEAR	1.1628	1.0000	0.9615	0.9259	0.8333	0.8621	0.7813	0.7266	0.6667
519	NO OTHER SOLID	2/ 8/14/ 0/3/0	CLEAR	1.1364	1.0870	0.9804	0.8929	0.8772	0.9259	0.8929	0.7813	0.7376
524	NO OTHER SOLID	2/ 9/14/ 0/5/0	CLEAR	1.1111	1.0638	0.8475	0.7353	0.6494	0.5816	0.4762	0.3731	0.3165
526	NO OTHER SOLID	2/ 7/14/ 0/3/0	CLEAR	1.1905	1.0204	1.0000	0.8772	0.8621	0.9434	0.9259	0.8675	0.7692
529	NO OTHER SOLID	2/10/14/ 0/3/0	CLEAR	0.9615	1.0870	1.0204	0.9259	0.7937	0.8333	0.8621	0.8197	0.7692
545	NO OTHER SOLID	2/ 5/16/ 0/3/0	CLEAR	1.1564	0.8621	0.8333	0.7937	0.6667	0.5695	0.4132	0.2959	0.2564
547	NO OTHER SOLID	2/ 5/15/ 0/3/0	CLEAR	1.1905	1.0204	0.9259	0.8621	0.8065	0.8065	0.7266	0.6329	0.5814
550	NO OTHER SOLID	2/ 5/15/ 0/3/0	CLEAR	1.0638	1.0204	0.9804	0.9091	0.8197	0.8772	0.7937	0.7042	0.6869
553	NO OTHER SOLID	2/ 5/13/ 0/3/0	CLEAR	1.2195	1.0638	0.9434	0.8772	0.8929	0.9091	0.7937	0.7353	0.7062
557	NO OTHER SOLID	2/ 5/14/ 0/3/0	CLEAR	1.1111	0.9804	1.0000	0.9091	0.8475	0.8621	0.8197	0.7813	0.7692
560	NO OTHER SOLID	2/ 7/14/ 0/3/0	CLEAR	1.0870	1.0000	0.8772	0.8475	0.8333	0.8333	0.7937	0.7463	0.6944
561	NO OTHER SOLID	2/13/14/ 0/3/0	CLEAR	1.2821	1.0417	0.8929	0.8929	0.9434	0.7576	0.7576	0.6757	0.5952
568	NO OTHER SOLID	2/ 7/14/ 0/3/0	CLEAR	1.1628	1.0638	0.9615	0.8772	0.8475	0.9091	0.8772	0.7813	0.6944
574	NO OTHER SOLID	6/ 6/14/ 0/5/0	CLEAR	1.1111	1.0000	0.9259	0.8621	0.8333	0.8333	0.8197	0.7463	0.6737
583	NO OTHER SOLID	2/ 3/14/ 0/3/0	CLEAR	1.1628	1.0417	0.9434	0.9615	0.8621	0.8772	0.7813	0.7163	0.6579
586	NO OTHER SOLID	2/ 5/14/ 0/3/0	CLEAR	1.0638	1.0204	0.9259	0.9091	0.8065	0.8333	0.7813	0.7163	0.6694
588	NO OTHER SOLID	2/ 4/14/ 0/5/0	CLEAR	0.9615	0.9259	0.6667	0.4902	0.3759	0.3650	0.3356	0.3226	0.2000
596	NO OTHER SOLID	2/ 4/14/ 0/3/0	CLEAR	1.0870	1.1111	1.0000	0.8475	0.8065	0.8475	0.8197	0.7576	0.7062
598	NO OTHER SOLID	3/18/ 0/5/13/0	CLEAR	1.0870	1.0870	1.0000	0.8621	0.8772	0.8621	0.8333	0.8197	0.7266
607	NO OTHER SOLID	2/ 7/13/ 0/3/0	CLEAR	1.0204	0.9804	0.9091	0.8772	0.8475	0.8475	0.7937	0.6944	0.6667
609	NO OTHER SOLID	2/ 7/14/ 0/3/0	CLEAR	1.1111	1.0204	1.0204	0.9615	0.9615	0.8929	0.8772	0.8333	0.7692
634	NO OTHER SOLID	2/ 6/14/ 0/3/0	CLEAR	1.1628	1.0638	0.9259	0.8065	0.8475	0.8772	0.8333	0.7463	0.6579
638	NO OTHER SOLID	2/ 5/14/ 0/3/0	CLEAR	1.0638	0.9615	1.0000	0.8621	0.8929	0.8621	0.7692	0.6757	0.6329
640	NO OTHER SOLID	3/18/ 0/5/13/0	CLEAR	1.2195	1.0417	0.9091	0.9804	0.9434	0.8621	0.8333	0.8065	0.7937
643	NO OTHER SOLID	2/ 7/14/ 0/3/0	CLEAR	1.0638	1.0000	0.9434	0.8929	0.8929	0.8621	0.8065	0.7163	0.6694
654	NO OTHER SOLID	6/ 0/ 0/ 0/0/0	CLEAR	0.0000	0.0000	0.0000	0.0000	0.0000	0.0000	0.0000	0.0000	0.0000
659	NO OTHER SOLID	2/ 7/15/ 0/3/0	CLEAR	1.0638	0.8772	0.8929	0.7937	0.7353	0.7062	0.5952	0.4237	0.2994
662	NO OTHER SOLID	2/ 9/15/ 0/3/0	CLEAR	1.0638	1.0000	0.9091	0.8929	0.8065	0.7353	0.7376	0.7163	0.6694
665	NO OTHER SOLID	2/ 4/14/ 0/3/0	CLEAR	1.0204	1.1111	1.0617	0.9434	0.9615	0.8929	0.8065	0.8929	0.8675
680	NO OTHER SOLID	2/ 7/14/ 0/3/0	CLEAR	1.1628	1.0417	0.9434	0.9091	0.8621	0.8333	0.7813	0.7062	0.6329
682	NO OTHER SOLID	2/ 7/14/ 0/3/0	CLEAR	1.0870	0.9804	0.9091	0.7692	0.6944	0.6329	0.5556	0.4717	0.3968
683	NO OTHER SOLID	2/ 7/13/ 0/3/0	CLEAR	1.1628	0.9804	0.8929	0.7692	0.6494	0.6869	0.5556	0.4132	0.3165
692	NO OTHER SOLID	2/11/15/ 0/3/0	CLEAR	1.0870	1.0000	0.8621	0.7576	0.6667	0.6494	0.5556	0.3676	0.2809

705	NO OTHER SOLID	2/ 5/15/ 0/3/0	CLEAR	1.0204	0.9434	0.7937	0.8065	0.7692	0.7692	0.6694	0.5635	0.5695
706	NO OTHER SOLID	2/ 5/15/ 0/3/0	CLEAR	1.2195	1.0638	1.0000	0.8772	0.8197	0.7692	0.7163	0.6098	0.4950
709	NO OTHER SOLID	2/12/14/ 0/3/0	CLEAR	1.1111	1.0417	0.9259	0.8333	0.8621	0.8621	0.7937	0.6667	0.5618
712	NO OTHER SOLID	2/ 7/13/ 0/3/0	CLEAR	1.0870	1.0000	0.9434	0.9259	0.8929	0.8929	0.8333	0.7692	0.6757
718	NO OTHER SOLID	2/ 7/14/ 0/5/0	CLEAR	1.1564	1.0638	0.9434	0.8675	0.9091	0.8772	0.8065	0.7576	0.7246
720	NO OTHER SOLID	2/ 7/14/ 0/3/0	CLEAR	1.0870	1.0870	0.9434	0.8065	0.7463	0.6849	0.6098	0.5263	0.4565
723	NO OTHER SOLID	2/ 7/14/ 0/3/0	CLEAR	1.2195	1.0204	0.9804	0.8929	0.8333	0.8772	0.8197	0.7692	0.6329
731	NO OTHER SOLID	2/ 7/14/ 0/5/0	CLEAR	1.0417	0.9804	0.8475	0.8197	0.7246	0.7937	0.7353	0.6579	0.5682
732	NO OTHER SOLID	2/ 7/15/ 0/3/0	CLEAR	1.1564	1.0638	0.9434	0.8929	0.8621	0.8333	0.8197	0.7813	0.7692
738	NO OTHER SOLID	2/11/14/ 0/3/0	CLEAR	1.0000	1.0000	0.8772	0.8475	0.7143	0.6329	0.5263	0.4310	0.3472
739	NO OTHER SOLID	2/ 7/13/ 0/3/0	CLEAR	1.1111	0.9615	0.8929	0.8772	0.8475	0.7937	0.7163	0.6944	0.6329
741	NO OTHER SOLID	2/ 7/15/ 0/3/0	CLEAR	1.1564	0.9434	0.9091	0.8772	0.8475	0.7937	0.6757	0.6026	0.5102
742	NO OTHER SOLID	2/ 9/14/ 0/3/0	CLEAR	1.1564	0.9804	0.9434	0.8772	0.7937	0.7692	0.6667	0.5747	0.5000
749	NO OTHER SOLID	2/ 7/14/ 0/3/0	CLEAR	1.0870	1.0638	0.9434	0.8197	0.8621	0.8772	0.8197	0.8065	0.6964
755	NO OTHER SOLID	2/13/15/ 0/3/0	CLEAR	1.2500	0.9259	0.9259	0.8772	0.8333	0.8065	0.7692	0.6667	0.5618
759	NO OTHER SOLID	2/ 7/14/ 0/3/0	CLEAR	1.1905	0.9615	0.9434	0.8475	0.7937	0.8065	0.7463	0.7042	0.6329
767	NO OTHER SOLID	2/11/14/ 0/3/0	CLEAR	1.1905	0.9804	0.8929	0.8772	0.7813	0.7143	0.6579	0.5435	0.4717
774	NO OTHER SOLID	2/ 9/14/ 0/5/0	CLEAR	1.0870	0.9804	0.7937	0.7692	0.6944	0.5882	0.4237	0.2825	0.2069
775	NO OTHER SOLID	2/ 9/14/ 0/3/0	CLEAR	1.2500	1.1111	0.8929	0.8929	0.7937	0.8197	0.7692	0.7246	0.6250
778	NO OTHER SOLID	2/ 5/15/ 0/3/0	CLEAR	1.1111	0.9615	0.9804	0.9615	0.8772	0.8621	0.7937	0.7937	0.8065
783	NO OTHER SOLID	2/ 9/16/ 0/5/0	CLEAR	1.0870	0.9434	0.8197	0.7937	0.7246	0.6579	0.5495	0.3676	0.2500
789	NO OTHER SOLID	2/ 7/14/ 0/3/0	CLEAR	1.1111	0.9434	0.8772	0.8475	0.7937	0.7813	0.7062	0.6494	0.5435
793	NO OTHER SOLID	3/18/ 0/32/0/0	CLEAR	0.9804	0.9804	0.9091	0.7463	0.7692	0.8197	0.6757	0.5882	0.4717
797	NO OTHER SOLID	2/ 7/14/ 0/5/0	CLEAR	1.1111	1.0000	0.9091	0.7353	0.7062	0.7246	0.6610	0.5682	0.4950
799	NO OTHER SOLID	2/ 9/15/ 0/3/0	CLEAR	0.8333	0.9259	0.7813	0.7813	0.8065	0.7246	0.6694	0.6098	0.4630
801	NO OTHER SOLID	2/ 7/14/ 0/3/0	CLEAR	0.9804	0.9434	0.9259	0.8772	0.8475	0.8675	0.7813	0.7062	0.6329
804	NO OTHER SOLID	2/ 5/15/ 0/5/0	CLEAR	1.1564	0.9804	0.8197	0.6869	0.6329	0.5556	0.4386	0.2660	0.2336
808	NO OTHER SOLID	2/ 5/15/ 0/3/0	CLEAR	1.0417	0.9615	0.9615	0.8929	0.7576	0.7353	0.6849	0.5882	0.5263
812	NO OTHER SOLID	2/11/14/ 0/5/0	CLEAR	1.0417	0.8929	0.8197	0.7937	0.7143	0.6757	0.5495	0.4310	0.3356
813	NO OTHER SOLID	6/ 0/ 0/ 0/0/0	11.740	1.0670	1.0204	0.8475	0.8197	0.6944	0.5682	0.4202	0.2825	0.0000
819	NO OTHER SOLID	2/ 7/15/ 0/3/0	CLEAR	0.9434	1.0000	0.8929	0.8621	0.7692	0.8197	0.7062	0.6944	0.5952
823	NO OTHER SOLID	2/13/14/ 0/3/0	CLEAR	1.1111	0.9091	0.8929	0.8621	0.7813	0.7692	0.7062	0.6026	0.5376
825	NO OTHER SOLID	2/ 7/14/ 0/3/0	CLEAR	0.9615	0.9434	0.8475	0.8475	0.8065	0.7937	0.7937	0.6757	0.6757

915	NO OTHER SOLID	2/ 7/14/ 0/3/0	CLEAR	1.0204	0.8929	0.7813	0.7576	0.7353	0.6579	0.5882	0.4545	0.3546
917	NO OTHER SOLID	2/11/15/ 0/5/0	CLEAR	1.0417	0.8772	0.9804	0.8675	0.9091	0.6757	0.7353	0.7163	0.7163
919	NO OTHER SOLID	2/ 7/15/ 0/3/0	CLEAR	1.1564	1.0638	0.9091	0.8333	0.8065	0.7813	0.7266	0.6757	0.5952
922	NO OTHER SOLID	2/11/15/ 0/5/0	CLEAR	0.9615	0.9804	0.9091	0.8929	0.8929	0.8675	0.7937	0.7353	0.6379
928	NO OTHER SOLID	2/ 7/16/ 0/5/0	CLEAR	0.9615	0.8772	0.8065	0.6869	0.6098	0.5952	0.5000	0.4310	0.3704
944	NO OTHER SOLID	2/ 7/14/ 0/3/0	CLEAR	1.3158	1.0638	0.9804	0.9634	0.8772	0.8621	0.8929	0.8333	0.7163
945	NO OTHER SOLID	2/11/14/ 0/5/0	CLEAR	1.1364	0.9804	0.9091	0.8675	0.8065	0.7813	0.6579	0.5435	0.5051
946	NO OTHER SOLID	2/ 5/15/ 0/3/0	CLEAR	1.1111	1.0417	0.9804	0.8929	0.8929	0.8621	0.8197	0.8065	0.7692
954	NO OTHER SOLID	2/ 5/15/ 0/3/0	CLEAR	1.1364	0.9091	0.7463	0.7062	0.6410	0.6024	0.5208	0.4545	0.4167
955	NO OTHER SOLID	2/11/14/ 0/5/0	CLEAR	0.8929	0.8929	0.8065	0.8772	0.7163	0.7463	0.6694	0.5618	0.5263
958	NO OTHER SOLID	2/ 9/15/ 0/3/0	CLEAR	1.1364	1.0000	0.9091	0.8929	0.9259	0.8929	0.8675	0.7937	0.7266
959	NO OTHER SOLID	2/ 5/16/ 0/5/0	CLEAR	1.1905	1.0638	0.8929	0.7353	0.6098	0.4545	0.2907	0.1923	0.2326
964	NO OTHER SOLID	2/ 9/15/ 0/3/0	CLEAR	1.0000	0.9615	0.9259	0.8772	0.8333	0.8929	0.7937	0.7353	0.6410
967	NO OTHER SOLID	2/ 5/15/ 0/3/0	CLEAR	1.0870	1.0204	0.9434	0.7937	0.8197	0.8475	0.8065	0.7692	0.7266
968	NO OTHER SOLID	2/ 4/14/ 0/5/0	CLEAR	1.0638	0.9804	0.8333	0.8621	0.8333	0.7353	0.7163	0.5952	0.4808
971	NO OTHER SOLID	2/13/15/ 0/3/0	CLEAR	1.1628	0.9804	0.8772	0.8929	0.8621	0.8772	0.8333	0.7692	0.6944
974	NO OTHER SOLID	2/ 9/15/ 0/5/0	CLEAR	1.0870	0.9615	0.8772	0.8675	0.7353	0.7353	0.7266	0.6667	0.5814
980	NO OTHER SOLID	2/11/16/ 0/5/0	CLEAR	0.0000	0.0000	0.0000	0.0000	0.0000	0.0000	0.0000	0.0000	0.5102
984	NO OTHER SOLID	2/ 7/14/ 0/5/0	CLEAR	1.0417	0.9091	0.8621	0.8197	0.7463	0.7266	0.7163	0.6610	0.5814
988	NO OTHER SOLID	2/12/14/ 0/5/0	CLEAR	1.1111	0.9804	0.9434	0.8675	0.8197	0.8197	0.7163	0.6610	0.5536
989	NO OTHER SOLID	2/ 7/15/ 0/5/0	CLEAR	1.2195	1.0204	0.8475	0.8621	0.8333	0.8333	0.7266	0.6944	0.6173
990	NO OTHER SOLID	2/ 5/14/ 0/3/0	CLEAR	1.1564	1.1111	1.0204	1.0000	0.9259	0.9091	0.9434	0.8929	0.8929
991	NO OTHER SOLID	2/ 9/14/ 0/5/0	CLEAR	1.0870	1.0000	0.9091	0.9259	0.8929	0.9634	0.8621	0.8333	0.7937
996	NO OTHER SOLID	2/11/14/ 0/3/0	CLEAR	1.1564	1.0638	0.9091	0.8333	0.8197	0.8197	0.7692	0.7062	0.6098
1000	NO OTHER SOLID	2/ 7/14/ 0/3/0	CLEAR	1.1364	1.0204	0.9259	0.8621	0.8929	0.8621	0.8197	0.7576	0.6024
1005	NO OTHER SOLID	2/ 5/14/ 0/3/0	CLEAR	1.1628	1.0204	0.9615	0.7813	0.7163	0.6964	0.6329	0.5767	0.5051
1010	NO OTHER SOLID	2/ 9/15/ 0/5/0	CLEAR	1.0000	0.9804	0.8621	0.7937	0.7576	0.7576	0.6869	0.6694	0.5682
1011	NO OTHER SOLID	2/ 9/15/ 0/3/0	CLEAR	1.1628	0.9804	0.9615	0.9259	0.8929	0.8929	0.8929	0.7813	0.7266
1016	NO OTHER SOLID	1/ 0/ 0/12/1/0	CLEAR	0.0000	0.0000	0.0000	0.0000	0.0000	0.0000	0.0000	0.0000	0.0000
1020	NO OTHER SOLID	2/ 7/15/ 0/3/0	CLEAR	1.0204	1.0000	0.9434	0.9259	0.8772	0.8621	0.8675	0.8675	0.7576
1025	NO OTHER SOLID	2/ 5/14/ 0/3/0	CLEAR	1.1905	1.0870	1.0000	0.8621	0.9259	0.9634	0.9259	0.8197	0.8065
1030	NO OTHER SOLID	2/ 7/15/ 0/5/0	CLEAR	0.9434	0.8929	0.9091	0.8065	0.8065	0.7663	0.7062	0.6694	0.5536
1034	NO OTHER SOLID	2/ 5/14/ 0/3/0	CLEAR	1.0638	1.0000	0.9259	0.8929	0.7813	0.8772	0.7813	0.7692	0.6667

1040	NO OTHER SOLID	2/11/14/ 0/3/0	CLEAR	1.3158	1.1364	0.9259	0.9434	0.8929	0.9091	0.8621	0.8065	0.7463
1042	NO OTHER SOLID	2/ 7/15/ 0/3/0	CLEAR	1.2195	0.9615	0.9434	0.8475	0.8772	0.8333	0.7062	0.6494	0.5747
1047	NO OTHER SOLID	2/11/14/ 0/3/0	CLEAR	1.0204	1.0204	0.9804	0.9091	0.8333	0.8333	0.7937	0.7353	0.6410
1051	NO OTHER SOLID	2/ 6/14/ 0/3/0	CLEAR	1.0417	1.0000	0.9259	0.8621	0.7692	0.7576	0.6849	0.6173	0.5682
7	1ST OF 2 SOLIDS	2/11/14/ 0/3/0	CLEAR	0.9804	1.0417	0.8333	0.7353	0.6667	0.5882	0.5319	0.3676	0.3012
7	2ND OF 2 SOLIDS	2/11/14/ 0/3/0	CLEAR	0.9434	1.0000	0.8065	0.6849	0.5882	0.5376	0.4664	0.3425	0.2564
12	1ST OF 2 SOLIDS	1/ 0/ 0/25/1/0	CLEAR	0.0000	0.0000	0.0000	0.0000	0.0000	0.0000	0.0000	0.0000	0.0000
12	2ND OF 2 SOLIDS	2/10/16/ 0/3/0	CLEAR	1.0417	1.0000	0.8772	0.7692	0.6579	0.5695	0.6630	0.2232	0.1232
22	1ST OF 2 SOLIDS	1/ 0/ 0/25/1/0	CLEAR	0.9804	1.1111	0.8333	0.9615	0.8475	0.7143	0.9259	0.8621	0.9259
22	2ND OF 2 SOLIDS	1/ 9/ 6/ 1/2/0	CLEAR	1.0000	0.9804	0.8475	0.4673	1.5625	0.9804	0.9804	0.9804	0.9804
25	1ST OF 2 SOLIDS	2/ 7/14/ 0/3/0	CLEAR	1.0000	1.1111	0.9615	0.9091	0.9259	0.8675	0.9091	0.7813	0.7246
25	2ND OF 2 SOLIDS	2/ 5/15/ 0/3/0	CLEAR	1.0417	1.2195	0.9434	0.8475	0.9259	0.8333	0.8197	0.7143	0.6667
46	1ST OF 2 SOLIDS	2/ 7/14/ 0/3/0	CLEAR	1.1111	1.1111	0.8621	0.8621	0.7937	0.7813	0.7813	0.6410	0.5952
46	2ND OF 2 SOLIDS	2/ 7/14/ 0/3/0	CLEAR	1.0638	1.1111	0.8621	0.7692	0.7353	0.5882	0.4587	0.5263	0.4464
51	1ST OF 2 SOLIDS	1/ 0/ 0/18/1/0	CLEAR	1.0638	1.2500	1.0204	1.0000	1.0870	0.9804	1.0417	0.8929	0.8621
51	2ND OF 2 SOLIDS	2/11/14/ 0/5/0	CLEAR	1.1628	1.1111	0.9259	0.8065	0.7937	0.7692	0.7692	0.6410	0.6329
55	1ST OF 2 SOLIDS	2/ 7/14/ 0/3/0	CLEAR	1.1628	1.0870	0.9259	0.8475	0.8929	0.8197	0.8772	0.7463	0.6849
55	2ND OF 2 SOLIDS	2/ 7/14/ 0/3/0	CLEAR	1.1111	1.1111	0.9259	0.8772	0.8929	0.8675	0.8772	0.7246	0.6250
59	1ST OF 2 SOLIDS	2/ 7/14/ 0/3/0	CLEAR	1.1564	1.3158	0.9804	0.9091	0.9091	0.8772	0.9434	0.8065	0.7576
59	2ND OF 2 SOLIDS	2/ 9/15/ 0/3/0	CLEAR	1.0204	1.0638	0.8772	0.8772	0.8197	0.7692	0.7692	0.5263	0.4630
62	1ST OF 2 SOLIDS	1/ 0/ 0/ 4/1/0	CLEAR	1.2500	0.7246	1.0417	0.7937	1.2195	1.0417	1.0870	0.6667	0.6250
62	2ND OF 2 SOLIDS	2/ 9/15/ 0/3/0	CLEAR	1.0870	1.1364	0.9091	0.8772	0.8065	0.7353	0.6849	0.5263	0.4310
64	1ST OF 2 SOLIDS	2/ 7/13/ 0/3/0	CLEAR	1.0204	1.0417	0.8772	0.8475	0.8333	0.8333	0.7692	0.6944	0.6494
64	2ND OF 2 SOLIDS	2/ 7/13/ 0/3/0	CLEAR	1.0638	1.0870	0.9259	0.8475	0.8333	0.7937	0.7692	0.6667	0.5952
65	1ST OF 2 SOLIDS	1/ 0/ 0/11/1/0	CLEAR	1.5152	1.2195	1.0417	0.9804	0.7813	0.9259	1.0000	0.7937	1.0638
65	2ND OF 2 SOLIDS	2/11/13/ 0/3/0	CLEAR	1.1111	1.1628	0.8772	0.8197	0.8065	0.7692	0.7692	0.6849	0.6173
76	1ST OF 2 SOLIDS	2/ 7/15/ 0/3/0	CLEAR	1.0638	1.2195	0.9091	0.9091	0.8772	0.7692	0.7463	0.7353	0.6757
76	2ND OF 2 SOLIDS	2/ 5/15/ 0/3/0	CLEAR	1.0870	1.1364	0.9091	0.8475	0.8065	0.7937	0.7937	0.6849	0.6579
86	1ST OF 2 SOLIDS	1/ 1/ 1/ 1/1/0	CLEAR	1.1364	0.9091	0.8772	0.6854	0.5695	1.1111	1.2500	1.1111	0.7576
86	2ND OF 2 SOLIDS	2/ 7/15/ 0/3/0	CLEAR	0.9804	1.0417	0.8475	0.8197	0.7062	0.5695	0.3731	0.2119	0.1742
91	1ST OF 2 SOLIDS	1/ 2/ 4/ 1/1/0	CLEAR	0.0000	0.0000	0.0000	0.0000	0.0000	0.0000	0.0000	0.0000	0.0000
91	2ND OF 2 SOLIDS	2/ 7/15/ 0/3/0	CLEAR	1.0638	1.0870	0.9091	0.7937	0.7246	0.6757	0.6610	0.5695	0.4673
105	1ST OF 2 SOLIDS	2/13/15/ 0/3/0	CLEAR	1.1111	1.0204	0.9615	0.8197	0.8333	0.7692	0.8197	0.6250	0.6579
105	2ND OF 2 SOLIDS	2/13/15/ 0/3/0	CLEAR	1.1111	1.1111	0.8197	0.8065	0.6849	0.5952	0.5208	0.3876	0.3125
106	1ST OF 2 SOLIDS	2/ 9/15/ 0/3/0	CLEAR	1.0870	1.1111	0.9091	0.8675	0.8772	0.8065	0.7937	0.5882	0.5495
106	2ND OF 2 SOLIDS	2/ 9/15/ 0/3/0	CLEAR	1.0870	1.1111	0.8621	0.8675	0.7937	0.7376	0.6579	0.5682	0.4902
115	1ST OF 2 SOLIDS	3/18/ 0/32/3/0	CLEAR	1.0204	0.8929	0.9634	0.9091	0.8333	0.8333	0.8772	0.7692	0.7246
115	2ND OF 2 SOLIDS	2/11/13/ 0/4/0	9.730	0.9804	1.0000	0.8621	0.7692	0.6757	0.5376	0.2688	0.0000	0.0000
121	1ST OF 2 SOLIDS	1/ 0/ 0/11/1/0	CLEAR	1.0204	1.1111	1.0638	0.8772	0.8333	1.0000	1.0870	0.8333	0.8065
121	2ND OF 2 SOLIDS	2/11/15/ 0/3/0	CLEAR	1.0638	1.0870	0.8475	0.8197	0.7813	0.7246	0.6849	0.5433	0.4762
152	1ST OF 2 SOLIDS	2/11/14/ 0/3/0	10.730	0.9804	1.0870	0.7692	0.6494	0.5319	0.0734	0.1389	0.1166	0.0000
152	2ND OF 2 SOLIDS	2/ 5/14/ 0/3/0	10.430	1.0000	0.8772	0.5682	0.1678	0.1222	0.1618	0.1613	0.0000	0.0000

162	1ST OF 2 SOLIDS	2/ 5/13/ 0/3/0	CLEAR	1.0000	1.0417	1.0204	0.7353	0.8063	0.7353	0.7266	0.5376	0.2631
162	2ND OF 2 SOLIDS	2/11/15/ 0/3/0	CLEAR	1.0417	1.0000	0.8772	0.8475	0.7692	0.7353	0.7062	0.4717	0.2767
165	1ST OF 2 SOLIDS	2/ 5/13/ 0/3/0	CLEAR	1.2821	1.1364	0.8621	0.8772	0.7937	0.7353	0.7463	0.6579	0.4505
165	2ND OF 2 SOLIDS	2/ 8/14/ 0/3/0	CLEAR	1.0417	1.0870	0.9091	0.7937	0.7576	0.7266	0.7353	0.5767	0.4587
172	1ST OF 2 SOLIDS	2/ 5/13/ 0/3/0	CLEAR	0.9434	1.0000	0.8333	0.7463	0.7813	0.7463	0.6849	0.4854	0.4464
172	2ND OF 2 SOLIDS	2/ 7/13/ 0/3/0	CLEAR	0.9091	1.0000	0.7576	0.7576	0.7937	0.6944	0.6737	0.5155	0.4274
177	1ST OF 2 SOLIDS	6/ 4/ 6/ 0/3/0	CLEAR	1.0870	1.1905	0.9259	0.9434	0.9091	0.8621	0.8197	0.7692	0.7246
177	2ND OF 2 SOLIDS	6/ 4/ 6/ 0/3/0	CLEAR	1.1905	1.0638	0.8333	0.7163	0.7353	0.6667	0.6230	0.5263	0.4808
180	1ST OF 2 SOLIDS	3/19/ 0/33/3/0	CLEAR	0.9615	1.0638	0.8621	0.6849	0.7937	0.7937	0.7813	0.6579	0.6410
180	2ND OF 2 SOLIDS	3/19/ 0/33/3/0	CLEAR	1.0638	1.0638	0.7463	0.7576	0.8475	0.7463	0.7266	0.6329	0.5682
198	1ST OF 2 SOLIDS	2/ 5/14/ 0/3/0	CLEAR	1.0417	1.0417	0.8475	0.8333	0.8621	0.7353	0.7937	0.6250	0.4762
198	2ND OF 2 SOLIDS	2/ 7/13/ 0/3/0	CLEAR	1.0870	1.1111	0.9434	0.8621	0.7813	0.7813	0.7813	0.6250	0.5102
200	1ST OF 2 SOLIDS	2/ 5/14/ 0/3/0	CLEAR	1.0417	1.0870	0.8929	0.7937	0.7937	0.7813	0.7463	0.6494	0.5155
200	2ND OF 2 SOLIDS	2/ 6/14/ 0/3/0	CLEAR	1.0204	1.1111	0.8333	0.8065	0.7937	0.7576	0.7353	0.5952	0.5000
207	1ST OF 2 SOLIDS	2/15/15/ 0/3/0	CLEAR	1.0638	1.0870	0.9091	0.8929	0.8475	0.8065	0.7937	0.6494	0.5695
207	2ND OF 2 SOLIDS	3/17/ 0/53/3/0	CLEAR	1.1111	1.1628	0.8621	0.7813	0.6757	0.5952	0.5682	0.4386	0.3356
223	1ST OF 2 SOLIDS	3/19/ 0/31/3/0	CLEAR	1.0638	1.1364	0.7937	0.7813	0.7576	0.6579	0.5952	0.4717	0.3846
223	2ND OF 2 SOLIDS	2/ 6/14/ 0/3/0	CLEAR	0.9804	1.0000	0.8772	0.7813	0.7576	0.7163	0.6494	0.4854	0.3759
232	1ST OF 2 SOLIDS	2/ 9/13/ 0/3/0	CLEAR	1.1564	1.0417	0.9259	0.8772	0.8197	0.7813	0.7353	0.5952	0.5495
232	2ND OF 2 SOLIDS	2/ 4/13/ 0/3/0	CLEAR	1.1111	1.0870	0.7813	0.6230	0.5155	0.4505	0.2961	0.1969	0.2183
238	1ST OF 2 SOLIDS	3/18/ 0/ 0/0/0	CLEAR	1.0417	1.1111	0.8621	0.7813	0.7813	0.6944	0.6329	0.4762	0.3817
238	2ND OF 2 SOLIDS	2/ 4/13/ 0/3/0	CLEAR	1.0417	1.1111	0.8621	0.7813	0.7813	0.6944	0.6329	0.4762	0.3817
249	1ST OF 2 SOLIDS	2/ 5/14/ 0/3/0	CLEAR	1.0870	1.1111	0.9434	0.8929	0.8929	0.8475	0.9259	0.8065	0.7246
249	2ND OF 2 SOLIDS	2/ 5/14/ 0/3/0	CLEAR	1.1111	1.1364	0.9259	0.8621	0.8772	0.7692	0.7576	0.6096	0.5208
254	1ST OF 2 SOLIDS	2/11/13/ 0/3/0	CLEAR	0.9804	1.1364	0.8929	0.8929	0.8621	0.7576	0.8065	0.7353	0.6757
254	2ND OF 2 SOLIDS	2/11/13/ 0/3/0	CLEAR	1.1111	1.2195	0.9091	0.8475	0.8197	0.8065	0.8065	0.7163	0.6757
258	1ST OF 2 SOLIDS	2/ 5/13/ 0/3/0	CLEAR	1.0417	1.1364	1.0204	0.9091	0.9091	0.8929	0.9804	0.8475	0.7937
258	2ND OF 2 SOLIDS	2/ 5/13/ 0/3/0	CLEAR	1.0638	1.0638	0.8772	0.7937	0.7692	0.7246	0.7576	0.6173	0.5376
276	1ST OF 2 SOLIDS	2/ 6/14/ 0/3/0	CLEAR	1.0417	1.1905	0.9615	0.8475	0.8475	0.8475	0.8929	0.7576	0.6944
276	2ND OF 2 SOLIDS	2/11/14/ 0/3/0	CLEAR	1.0638	1.0417	0.8475	0.8333	0.8475	0.7576	0.7353	0.6410	0.5618
303	1ST OF 2 SOLIDS	2/11/14/ 0/3/0	CLEAR	0.0000	0.0000	0.0000	0.0000	0.0000	0.0000	0.0000	0.8197	0.8621
303	2ND OF 2 SOLIDS	2/ 5/14/ 0/3/0	CLEAR	1.1905	1.1364	0.9091	0.9091	0.9259	0.6849	0.5618	0.6494	0.6494
304	1ST OF 2 SOLIDS	3/19/ 0/52/3/0	CLEAR	1.2195	1.2500	1.0204	0.9091	0.9259	0.8197	0.8772	0.7813	0.7463
304	2ND OF 2 SOLIDS	2/15/14/ 0/3/0	CLEAR	1.2500	1.1905	0.9615	0.8929	0.8929	0.8197	0.8475	0.7463	0.6410
333	1ST OF 2 SOLIDS	1/ 3/ 4/ 1/0/0	CLEAR	1.0417	1.1905	1.1111	1.0204	0.9434	0.8772	0.9615	0.8929	0.9615
333	2ND OF 2 SOLIDS	2/12/14/ 0/3/0	CLEAR	1.0638	1.0204	0.8929	0.8475	0.8197	0.6757	0.5556	0.4202	0.2675
346	1ST OF 2 SOLIDS	1/ 0/ 0/ 7/0/0	CLEAR	1.2821	0.8929	1.0638	1.0417	0.9434	1.0000	0.7576	1.0204	0.9091
346	2ND OF 2 SOLIDS	2/ 5/14/ 0/3/0	CLEAR	1.1364	1.0870	0.9259	0.8929	0.8065	0.7937	0.7576	0.6579	0.6098
363	1ST OF 2 SOLIDS	2/10/13/ 0/3/0	CLEAR	1.1111	1.1364	0.9615	0.8772	0.8475	0.8333	0.8621	0.7163	0.6098
363	2ND OF 2 SOLIDS	2/ 7/16/ 0/3/0	7.900	1.0204	0.9804	0.7463	0.6329	0.3704	0.0000	0.0000	0.0000	0.0000
364	1ST OF 2 SOLIDS	2/ 7/12/ 0/3/0	CLEAR	1.1628	1.1111	0.9259	0.8772	0.8621	0.8621	0.8621	0.7163	0.6579
364	2ND OF 2 SOLIDS	2/ 7/12/ 0/3/0	CLEAR	1.1111	1.1111	0.8929	0.8772	0.8772	0.8333	0.7813	0.6757	0.5882
368	1ST OF 2 SOLIDS	1/ 3/ 2/ 1/1/0	CLEAR	0.0000	0.0000	0.0000	0.0000	0.0000	0.0000	0.0000	0.0000	0.0000
368	2ND OF 2 SOLIDS	2/ 5/13/ 0/3/0	CLEAR	1.2500	1.1364	0.9091	0.8621	0.7692	0.8333	0.7937	0.6757	0.6329

370	1ST OF 2 SOLIDS	2/ 11/16/	0/3/0	CLEAR	0.0000	0.0000	0.0000	0.0000	0.0000	0.7692	0.8929	0.6667	0.3922
370	2ND OF 2 SOLIDS	2/ 9/14/	0/5/0	CLEAR	1.2195	1.0204	0.7143	0.6410	0.6024	0.6869	0.6579	0.5682	0.5319
380	1ST OF 2 SOLIDS	2/ 7/16/	0/5/0	CLEAR	0.0000	0.0000	0.0000	0.0000	0.0000	0.8197	0.7813	0.7266	0.6250
380	2ND OF 2 SOLIDS	2/11/14/	0/3/0	7.130	1.0638	0.8929	0.7576	0.5635	0.0000	0.0000	0.0000	0.0000	0.0000
383	1ST OF 2 SOLIDS	2/ 5/14/	0/3/0	CLEAR	1.1905	1.0000	0.9804	0.9289	0.8772	0.8929	0.8675	0.7813	0.6944
383	2ND OF 2 SOLIDS	2/ 7/14/	0/3/0	CLEAR	1.2195	1.0638	1.0000	0.9289	0.8333	0.9091	0.7937	0.7576	0.6869
385	1ST OF 2 SOLIDS	2/ 7/14/	0/3/0	CLEAR	1.1111	0.9804	0.8065	0.8333	0.7692	0.7576	0.6737	0.6250	0.5155
385	2ND OF 2 SOLIDS	2/ 9/14/	0/3/0	CLEAR	1.1905	0.8929	0.7576	0.6579	0.5635	0.6310	0.5289	0.2703	0.1235
401	1ST OF 2 SOLIDS	2/ 7/15/	0/5/0	CLEAR	1.1111	1.0000	0.9259	0.7692	0.6173	0.5155	0.3937	0.0358	0.2092
401	2ND OF 2 SOLIDS	2/ 7/15/	0/5/0	CLEAR	1.0870	0.7813	0.5263	0.1433	0.0630	0.1305	0.1946	0.1880	0.1484
422	1ST OF 2 SOLIDS	2/ 7/14/	0/3/0	CLEAR	1.1564	1.0870	1.0000	0.8772	0.9091	0.9259	0.8675	0.8333	0.7143
422	2ND OF 2 SOLIDS	2/ 7/14/	0/3/0	CLEAR	1.0638	0.9434	0.9091	0.8475	0.7692	0.7353	0.6098	0.5682	0.4717
430	1ST OF 2 SOLIDS	2/ 4/16/	0/5/0	CLEAR	1.0417	1.0000	1.0000	1.0000	0.7692	0.8475	0.8065	0.6667	0.6250
430	2ND OF 2 SOLIDS	1/ 3/ 8/	1/2/0	CLEAR	0.8772	1.1364	1.0417	0.9259	0.8197	0.8333	0.7937	0.6494	0.6379
445	1ST OF 2 SOLIDS	2/ 5/14/	0/3/0	CLEAR	1.0870	1.1364	0.9804	0.8929	0.9259	0.9259	0.9615	0.8929	0.8772
445	2ND OF 2 SOLIDS	2/ 5/14/	0/3/0	CLEAR	1.1628	0.9434	0.9259	0.8929	0.9091	0.9259	0.8621	0.7813	0.7576
508	1ST OF 2 SOLIDS	1/ 0/	0/20/1/0	CLEAR	1.0204	0.9804	0.8675	0.8197	0.7663	0.8333	0.7813	0.7143	0.6494
508	2ND OF 2 SOLIDS	2/ 7/16/	0/3/0	CLEAR	1.0417	0.8772	0.7246	0.5556	0.3521	0.2336	0.2688	0.2604	0.2500
545	1ST OF 2 SOLIDS	2/ 5/15/	0/3/0	CLEAR	1.0638	1.0870	0.9615	1.0417	0.8772	0.8772	0.8675	0.7463	0.7353
545	2ND OF 2 SOLIDS	2/ 7/15/	0/3/0	CLEAR	1.0870	1.0870	0.9804	0.9615	0.8772	0.8621	0.8065	0.7576	0.7143
573	1ST OF 2 SOLIDS	2/ 4/14/	0/3/0	CLEAR	1.1905	1.1628	1.0204	0.8621	0.8929	0.9259	0.7692	0.6579	0.7463
573	2ND OF 2 SOLIDS	2/ 4/14/	0/3/0	CLEAR	1.1564	1.0417	0.9804	0.9615	0.8772	0.7692	0.8333	0.7576	0.7692
601	1ST OF 2 SOLIDS	2/ 4/14/	0/3/0	CLEAR	1.0870	0.9615	0.8621	0.8475	0.8475	0.7353	0.6849	0.4545	0.4065
601	2ND OF 2 SOLIDS	2/ 9/15/	0/5/0	CLEAR	1.1564	1.0000	0.9259	0.7692	0.7353	0.6944	0.6024	0.4762	0.3968
603	1ST OF 2 SOLIDS	2/13/14/	0/3/0	CLEAR	1.0870	0.9804	0.8333	0.8065	0.7937	0.7813	0.6737	0.5882	0.4854
603	2ND OF 2 SOLIDS	2/ 4/14/	0/3/0	CLEAR	1.1564	1.0417	0.7576	0.5952	0.4386	0.2688	0.1592	0.1916	0.1543
604	1ST OF 2 SOLIDS	2/ 7/15/	0/3/0	CLEAR	1.0417	1.0417	0.8065	0.7937	0.7143	0.6494	0.5952	0.4587	0.3623
604	2ND OF 2 SOLIDS	2/ 3/13/	0/3/0	CLEAR	1.0870	0.9615	0.8197	0.6737	0.6250	0.5695	0.4386	0.3704	0.2924
615	1ST OF 2 SOLIDS	2/ 5/14/	0/3/0	CLEAR	1.0204	0.9615	0.8929	0.8772	0.7692	0.7813	0.7042	0.6098	0.5208
615	2ND OF 2 SOLIDS	2/ 5/14/	0/3/0	CLEAR	1.0870	0.9434	0.9434	0.7813	0.7576	0.7143	0.6494	0.5682	0.5263
641	1ST OF 2 SOLIDS	3/18/	0/52/5/0	CLEAR	1.3514	0.9804	1.0638	1.0000	1.0000	0.9634	0.9091	0.9434	0.9091
641	2ND OF 2 SOLIDS	2/ 3/14/	0/3/0	CLEAR	1.2500	1.1111	1.0000	0.9091	0.8621	0.8333	0.7576	0.6410	0.5376
677	1ST OF 2 SOLIDS	2/ 9/14/	0/5/0	CLEAR	0.0000	0.0000	0.0000	0.0000	0.7463	0.8475	0.7463	0.7937	0.7576
677	2ND OF 2 SOLIDS	2/13/14/	0/3/0	CLEAR	1.1564	1.0870	1.0617	0.9091	0.8333	0.8675	0.8197	0.7813	0.7143
726	1ST OF 2 SOLIDS	2/ 7/14/	0/3/0	CLEAR	1.0870	0.9615	0.8929	0.8621	0.8772	0.8475	0.7463	0.7143	0.6173
726	2ND OF 2 SOLIDS	2/ 9/14/	0/3/0	CLEAR	1.1564	1.0638	0.9259	0.8065	0.7353	0.7353	0.6098	0.5319	0.4386
735	1ST OF 2 SOLIDS	2/ 7/13/	0/3/0	CLEAR	1.1905	0.9804	0.9259	0.8929	0.8065	0.7937	0.6944	0.6849	0.5814
735	2ND OF 2 SOLIDS	2/ 5/15/	0/3/0	CLEAR	1.1111	0.9259	0.7813	0.6610	0.5635	0.5000	0.4464	0.3356	0.3086
737	1ST OF 2 SOLIDS	2/ 5/14/	0/3/0	CLEAR	1.0638	1.0204	0.9259	0.8929	0.8333	0.8333	0.7937	0.7463	0.6944
737	2ND OF 2 SOLIDS	2/ 5/15/	0/5/0	CLEAR	1.0638	0.9259	0.8065	0.6579	0.4623	0.3012	0.1742	0.1484	0.1538
752	1ST OF 2 SOLIDS	1/ 4/ 8/	1/2/0	CLEAR	1.1628	1.0000	0.9434	0.9091	0.8772	0.8929	0.7246	0.7143	0.7143
752	2ND OF 2 SOLIDS	2/11/14/	0/3/0	CLEAR	1.1628	1.0204	0.9804	0.9434	0.8772	0.8065	0.7937	0.7463	0.7143
761	1ST OF 2 SOLIDS	2/ 7/15/	0/5/0	CLEAR	1.0638	1.1111	0.9804	0.8929	0.9091	0.8772	0.8475	0.8197	0.7463
761	2ND OF 2 SOLIDS	2/ 7/15/	0/5/0	CLEAR	1.0870	1.0417	0.9091	0.8772	0.8065	0.8772	0.7937	0.7463	0.7246

766	1ST OF 2 SOLIDS	2/ 9/15/ 0/5/0	CLEAR	1.0638	1.0638	0.8929	0.8475	0.8197	0.8333	0.7813	0.7353	0.5952
766	2ND OF 2 SOLIDS	2/ 7/14/ 0/3/0	CLEAR	1.0870	1.0204	0.9091	0.8675	0.8475	0.8197	0.7163	0.6696	0.5682
809	1ST OF 2 SOLIDS	5/ 7/15/ 3/3/3	CLEAR	1.0204	0.9259	0.8475	0.7937	0.8197	0.8333	0.6494	0.4098	0.2762
809	2ND OF 2 SOLIDS	2/ 7/14/ 0/3/0	CLEAR	1.0638	0.9634	0.8621	0.8475	0.7266	0.6944	0.5814	0.4032	0.2890
817	1ST OF 2 SOLIDS	2/ 7/14/ 0/3/0	CLEAR	1.0417	1.0638	0.9434	0.8772	0.8475	0.8772	0.7692	0.7042	0.6410
817	2ND OF 2 SOLIDS	2/ 5/14/ 0/3/0	CLEAR	1.1628	1.0417	0.8929	0.8929	0.8333	0.7576	0.7062	0.6024	0.5263
841	1ST OF 2 SOLIDS	2/ 4/14/ 0/3/0	CLEAR	1.0870	1.1111	1.0870	1.0638	1.0638	0.8772	0.9615	0.8475	0.6098
841	2ND OF 2 SOLIDS	1/ 0/ 0/21/1/0	CLEAR	0.0000	0.0000	0.0000	0.0000	0.0000	0.0000	0.0000	0.0000	0.0000
844	1ST OF 2 SOLIDS	2/15/14/ 0/5/0	CLEAR	1.0417	0.9091	0.9259	0.8197	0.6757	0.5882	0.4587	0.3731	0.2092
844	2ND OF 2 SOLIDS	2/15/14/ 0/5/0	CLEAR	1.1905	0.9615	0.8065	0.7266	0.5952	0.5618	0.4425	0.3185	0.2174
893	1ST OF 2 SOLIDS	2/ 7/15/ 0/3/0	CLEAR	1.1628	1.0417	0.9259	0.7813	0.8475	0.8197	0.7266	0.6250	0.3597
893	2ND OF 2 SOLIDS	2/ 5/14/ 0/3/0	CLEAR	1.1628	0.8929	0.8772	0.8197	0.7937	0.7353	0.6329	0.5155	0.3571
895	1ST OF 2 SOLIDS	2/ 7/15/ 0/3/0	CLEAR	1.0638	1.0000	0.8197	0.8065	0.7463	0.7143	0.5882	0.4808	0.3165
895	2ND OF 2 SOLIDS	2/ 5/14/ 0/3/0	CLEAR	0.9804	0.9615	0.8065	0.6944	0.6098	0.5435	0.4425	0.3472	0.2703
949	1ST OF 2 SOLIDS	2/ 7/15/ 0/3/0	CLEAR	0.8929	0.7576	0.7463	0.8197	0.6757	0.6024	0.5263	0.4587	0.3597
949	2ND OF 2 SOLIDS	2/ 7/15/ 0/3/0	CLEAR	0.9804	0.9615	0.8333	0.7576	0.6173	0.5814	0.4310	0.3267	0.2174
970	1ST OF 2 SOLIDS	2/11/14/ 0/3/0	CLEAR	1.1111	1.0000	0.8621	0.8475	0.7937	0.8197	0.7143	0.6944	0.6024
970	2ND OF 2 SOLIDS	2/ 7/14/ 0/3/0	CLEAR	1.0638	1.0204	0.9091	0.7463	0.7143	0.6579	0.5536	0.4854	0.3876
1007	1ST OF 2 SOLIDS	2/ 7/14/ 0/5/0	CLEAR	1.0000	0.9615	0.8065	0.7692	0.8065	0.7663	0.7266	0.6494	0.5952
1007	2ND OF 2 SOLIDS	2/ 7/14/ 0/5/0	CLEAR	1.0000	0.9091	0.8333	0.8197	0.7576	0.7663	0.7062	0.6329	0.5682
39	1ST OF 3 SOLIDS	1/ 0/ 0/12/1/0	CLEAR	1.1111	1.2195	0.9804	0.9434	1.1111	1.0638	0.9434	0.9634	0.6944
39	2ND OF 3 SOLIDS	1/ 5/ 3/ 1/1/0	CLEAR	1.0417	1.0417	0.9259	0.8772	0.9091	0.7246	0.7143	0.6579	0.5747
39	3RD OF 3 SOLIDS	2/11/14/ 0/3/0	CLEAR	1.0204	1.0870	0.8929	0.8929	0.8621	0.6757	0.7463	0.6173	0.5495
44	1ST OF 3 SOLIDS	1/ 3/ 6/ 1/1/0	CLEAR	1.4706	1.1628	0.9615	0.8475	0.8333	0.8065	0.8065	0.6098	0.5051
44	2ND OF 3 SOLIDS	2/15/14/ 0/3/0	CLEAR	1.1564	1.0638	0.9434	0.9434	0.8333	0.7813	0.7143	0.5882	0.4717
44	3RD OF 3 SOLIDS	2/ 5/14/ 0/3/0	CLEAR	0.9434	1.0417	0.8475	0.5102	0.3521	0.2538	0.2961	0.2793	0.2604
81	1ST OF 3 SOLIDS	1/ 0/ 0/23/0/0	CLEAR	1.1628	0.9434	0.9259	0.7692	0.6329	0.5618	0.3571	0.5556	0.4505
81	2ND OF 3 SOLIDS	2/15/15/ 0/3/0	8.230	1.0204	0.9091	0.7042	0.6849	0.5000	0.0000	0.0000	0.0000	0.0000
81	3RD OF 3 SOLIDS	2/ 5/15/ 0/3/0	7.930	0.9804	0.9615	0.7042	0.5952	0.3876	0.0000	0.0000	0.0000	0.0000
94	1ST OF 3 SOLIDS	1/ 0/ 0/23/1/0	CLEAR	0.0000	0.0000	0.0000	0.0000	0.0000	0.0000	0.0000	0.0000	0.0000
94	2ND OF 3 SOLIDS	1/ 2/ 8/ 1/2/0	CLEAR	1.0204	1.0870	1.0417	0.9615	0.8475	0.7892	0.8065	0.6173	0.4202
94	3RD OF 3 SOLIDS	2/11/15/ 0/3/0	CLEAR	1.1111	1.0638	0.8197	0.8065	0.7463	0.6098	0.5319	0.3289	0.1901
129	1ST OF 3 SOLIDS	1/ 0/ 0/11/1/0	CLEAR	1.3889	1.0417	0.8333	0.9804	1.0417	0.9091	0.8772	0.9091	0.9434
129	2ND OF 3 SOLIDS	2/15/14/ 0/3/0	CLEAR	1.1628	1.0870	0.9804	0.9615	0.9091	0.8675	0.8929	0.7813	0.7143
129	3RD OF 3 SOLIDS	2/15/14/ 0/3/0	CLEAR	1.1628	1.1364	0.9259	0.9434	0.7692	0.6944	0.7163	0.6173	0.5435
149	1ST OF 3 SOLIDS	1/ 0/ 0/11/1/0	CLEAR	1.1364	1.0638	0.9259	0.8197	0.8772	0.8333	0.8621	0.7553	0.7813
149	2ND OF 3 SOLIDS	1/ 0/ 0/11/1/0	CLEAR	0.9259	1.1628	0.8621	0.8621	0.8772	0.8333	0.8475	0.7576	0.6667
149	3RD OF 3 SOLIDS	1/ 0/ 0/11/1/0	CLEAR	1.1111	1.1628	0.9434	0.8929	0.8772	0.8065	0.8065	0.7266	0.6849
168	1ST OF 3 SOLIDS	1/ 2/ 2/ 1/0/0	CLEAR	1.0870	1.1364	0.8772	0.8929	0.8333	0.7692	0.6944	0.5682	0.3937
168	2ND OF 3 SOLIDS	1/ 4/ 4/ 1/0/0	CLEAR	1.0870	1.0870	0.8197	0.8621	0.7813	0.6667	0.5263	0.5618	0.3650
168	3RD OF 3 SOLIDS	2/ 7/14/ 0/3/0	10.730	1.0870	1.0870	0.8197	0.8621	0.7813	0.6667	0.5263	0.2632	0.0000
228	1ST OF 3 SOLIDS	1/ 2/ 4/ 1/0/0	CLEAR	1.2195	0.8333	0.8197	0.6944	0.8333	1.2195	0.7376	0.7692	0.7062
228	2ND OF 3 SOLIDS	1/ 6/ 4/ 2/0/0	CLEAR	0.8929	0.9091	0.8065	0.7813	0.8772	0.9804	0.8065	0.7463	0.6757
228	3RD OF 3 SOLIDS	3/19/ 0/52/4/0	6.130	1.1628	0.9091	0.5952	0.0000	0.0000	0.0000	0.0000	0.0000	0.0000
236	1ST OF 3 SOLIDS	2/ 4/15/ 0/3/0	CLEAR	1.0417	1.0638	0.9259	0.8621	0.8197	0.8197	0.7813	0.6757	0.6250
236	2ND OF 3 SOLIDS	2/ 6/13/ 0/3/0	CLEAR	1.0870	1.0870	0.8929	0.8333	0.8065	0.7062	0.7266	0.6329	0.5495
236	3RD OF 3 SOLIDS	2/ 4/15/ 0/3/0	CLEAR	1.0870	1.1628	0.8621	0.8333	0.7463	0.6944	0.7062	0.6024	0.5263

267	1ST UP 3 SOLIDS	1/ 4/ 4/ 1/0/0	CLEAR	1.0417	1.1202	1.0630	U.0767	U.0767	U.0061	U.0402	U.0377
267	2ND OF 3 SOLIDS	1/ 4/ 4/ 1/0/0	CLEAR	1.1905	1.1628	0.9615	0.9091	0.8772	0.9091	0.7813	0.6849
267	3RD OF 3 SOLIDS	2/ 7/14/ 0/3/0	11.150	1.1564	1.0417	0.8772	0.6849	0.5747	0.6717	0.3356	0.0000
330	3RD OF 3 SOLIDS	2/ 7/14/ 0/3/0	CLEAR	1.1364	1.1364	0.9259	0.7937	0.7463	0.8065	0.6757	0.5882
390	1ST OF 3 SOLIDS	1/ 0/ 0/ 3/1/0	CLEAR	0.0000	0.0000	0.0000	0.0000	0.0000	0.0000	0.0000	0.0000
390	2ND OF 3 SOLIDS	1/ 3/ 8/ 1/2/0	CLEAR	0.9259	0.8772	0.9259	0.8621	0.9804	0.8621	0.8065	0.8197
390	3RD OF 3 SOLIDS	2/ 9/16/ 0/5/0	6.130	1.2500	0.9615	0.6494	0.0000	0.0000	0.0000	0.0000	0.0000
406	1ST OF 3 SOLIDS	2/ 5/16/ 0/3/0	CLEAR	0.0000	0.0000	0.0000	0.9615	0.8621	0.8065	0.8621	0.8197
406	2ND OF 3 SOLIDS	2/ 7/14/ 0/3/0	CLEAR	1.0870	0.9615	0.6667	0.7463	0.7376	0.7143	0.6024	0.6250
406	3RD OF 3 SOLIDS	2/ 7/14/ 0/3/0	CLEAR	1.0417	1.0204	0.6757	0.6849	0.6944	0.6494	0.5814	0.5208
471	1ST OF 3 SOLIDS	1/ 0/ 0/21/2/0	CLEAR	0.9259	1.0417	0.9259	0.9615	0.8621	0.8929	0.8475	0.8333
471	2ND OF 3 SOLIDS	2/ 5/14/ 0/3/0	CLEAR	1.1111	1.1111	0.9259	0.9615	0.8621	0.8929	0.8065	0.7813
471	3RD OF 3 SOLIDS	1/ 7/ 4/ 1/2/0	CLEAR	1.1364	1.0870	0.9434	0.9091	0.9091	0.8772	0.8065	0.7692
537	1ST OF 3 SOLIDS	2/ 7/14/ 0/3/0	CLEAR	1.1628	1.0417	0.9091	0.8197	0.8065	0.8197	0.7463	0.7143
537	2ND OF 3 SOLIDS	2/ 7/14/ 0/3/0	CLEAR	1.1111	1.0204	0.9091	0.8197	0.8065	0.7813	0.7143	0.6757
537	3RD OF 3 SOLIDS	3/17/ 0/53/6/0	CLEAR	1.0870	1.0204	0.8772	0.7937	0.8197	0.7576	0.7042	0.6494
592	1ST OF 3 SOLIDS	1/ 4/ 6/ 1/1/0	CLEAR	1.2500	0.8333	1.0000	1.0000	0.9434	0.8475	0.7246	0.7813
592	2ND OF 3 SOLIDS	1/ 0/ 0/ 7/1/0	CLEAR	1.2195	0.8621	0.9434	1.0204	0.9091	0.7813	0.7576	0.7143
592	3RD OF 3 SOLIDS	2/11/14/ 0/3/0	CLEAR	1.2195	0.9259	0.8475	0.8197	0.7463	0.6173	0.5376	0.4202
689	1ST OF 3 SOLIDS	1/ 7/ 4/ 1/1/0	CLEAR	0.9091	1.0870	0.9434	0.8621	0.7937	1.0417	0.8333	0.7937
689	2ND OF 3 SOLIDS	1/ 5/ 4/ 1/1/0	CLEAR	0.9804	1.1905	0.9091	0.8197	0.7937	0.9804	0.8475	0.7692
689	3RD OF 3 SOLIDS	2/ 7/14/ 0/3/0	CLEAR	2.5000	1.9231	1.1628	0.7246	0.6024	0.5319	0.5051	0.4717
715	1ST OF 3 SOLIDS	1/ 0/ 0/30/1/0	CLEAR	1.2195	0.9259	1.0204	0.8475	0.8772	0.9091	0.8621	0.8333
715	2ND OF 3 SOLIDS	2/11/14/ 0/3/0	CLEAR	1.1628	0.9804	0.9091	0.8475	0.8333	0.7813	0.6379	0.4545
715	3RD OF 3 SOLIDS	1/ 0/ 0/21/1/0	CLEAR	1.1628	0.9804	0.9091	0.8475	0.8333	0.7813	0.6379	0.4545
717	1ST OF 3 SOLIDS	2/11/12/ 0/5/0	CLEAR	0.8000	0.9000	0.9091	0.8000	0.9000	0.9000	0.9000	0.9000
717	2ND OF 3 SOLIDS	2/ 7/14/ 0/3/0	CLEAR	0.8621	0.9434	0.9091	0.8621	0.8333	0.7266	0.3087	0.2032
717	3RD OF 3 SOLIDS	2/ 7/14/ 0/3/0	CLEAR	0.8475	0.9615	0.8197	0.8772	0.7937	0.7062	0.4630	0.3521
751	1ST OF 3 SOLIDS	1/ 3/ 8/ 1/1/0	CLEAR	1.2821	0.9615	0.7813	0.7576	0.8772	0.8197	0.8333	0.7333
751	2ND OF 3 SOLIDS	1/ 0/ 0/11/1/0	CLEAR	0.0000	0.0000	0.0000	0.0000	0.0000	0.0000	0.0000	0.0000
751	3RD OF 3 SOLIDS	2/ 9/14/ 0/3/0	CLEAR	1.0204	0.9804	0.8333	0.8333	0.8065	0.7576	0.6964	0.6329
765	1ST OF 3 SOLIDS	2/ 7/14/ 0/3/0	CLEAR	1.0204	1.0638	1.0000	0.9259	0.7937	0.8929	0.8929	0.7333
765	2ND OF 3 SOLIDS	1/ 7/ 6/ 1/2/0	CLEAR	1.1111	0.9804	0.9615	0.9259	0.9434	0.9091	0.7813	0.7042
765	3RD OF 3 SOLIDS	2/ 9/14/ 0/3/0	CLEAR	1.0417	0.9615	0.9259	0.9091	0.7813	0.7692	0.6173	0.5435
806	1ST OF 3 SOLIDS	2/ 5/15/ 0/3/0	CLEAR	0.0000	0.0000	0.0000	0.9804	0.8621	0.8333	0.8772	0.8065
806	2ND OF 3 SOLIDS	1/ 3/ 6/ 1/1/0	CLEAR	1.4706	0.8929	0.4386	0.7333	0.7937	0.6250	0.5208	0.2618
806	3RD OF 3 SOLIDS	5/ 9/14/12/5/3	9.130	1.3158	0.9091	0.5155	0.6667	0.6587	0.0000	0.0000	0.0000
877	1ST OF 3 SOLIDS	2/ 5/14/ 0/3/0	CLEAR	1.1905	1.0204	0.8475	0.8772	0.9091	0.8065	0.8772	0.7042
877	2ND OF 3 SOLIDS	2/ 5/14/ 0/3/0	CLEAR	1.0638	1.0000	0.8197	0.8772	0.8675	0.7813	0.6667	0.6250
877	3RD OF 3 SOLIDS	2/ 5/14/ 0/3/0	CLEAR	1.0000	0.8621	0.8475	0.8333	0.7463	0.6329	0.5814	0.5376
890	1ST OF 3 SOLIDS	4/ 0/ 0/33/0/0	CLEAR	1.1111	0.9615	0.8065	0.7576	0.5882	0.6717	0.3759	0.2075
890	2ND OF 3 SOLIDS	2/ 3/14/ 0/3/0	CLEAR	1.0000	1.0204	0.8772	0.8475	0.7333	0.5882	0.3521	0.2119
890	3RD OF 3 SOLIDS	2/ 5/14/ 0/3/0	CLEAR	1.2500	1.0204	0.9259	0.8475	0.8065	0.7266	0.3356	0.2174
906	1ST OF 3 SOLIDS	1/ 3/ 6/ 1/2/0	CLEAR	0.8772	0.8772	0.8772	0.9259	0.8621	0.8621	0.7246	0.5682
906	2ND OF 3 SOLIDS	1/ 4/ 6/ 1/2/0	CLEAR	1.0000	0.8772	0.8475	0.8929	0.8065	0.8929	0.6410	0.5208
906	3RD OF 3 SOLIDS	2/ 7/15/ 0/5/0	CLEAR	1.0638	0.9615	0.9091	0.9259	0.7937	0.8065	0.5882	0.4386
957	1ST OF 3 SOLIDS	2/11/14/ 0/3/0	CLEAR	1.0870	1.2500	1.1905	0.9804	0.8621	0.8621	0.8929	0.7463
957	2ND OF 3 SOLIDS	2/ 7/14/ 0/5/0	CLEAR	1.1905	1.0417	1.0000	0.9259	0.8621	0.8333	0.8065	0.7692
957	3RD OF 3 SOLIDS	2/11/14/ 0/3/0	CLEAR	1.0870	1.0000	0.9434	0.8929	0.8065	0.8621	0.7463	0.6667

1008	1ST OF 3 SOLIDS	1/ 3/ 4/ 1/1/0	CLEAR	1.1905	1.0638	1.0204	0.9615	0.9434	0.9239	0.8621	0.7937	0.7813
1008	2ND OF 3 SOLIDS	1/ 7/ 4/ 1/1/0	CLEAR	1.1905	1.0638	1.0638	0.9259	0.9091	0.9091	0.8197	0.8063	0.7576
1008	3RD OF 3 SOLIDS	2/ 9/16/ 0/3/0	CLEAR	1.0417	1.0000	0.9091	0.8065	0.7576	0.6667	0.5618	0.4464	0.3401
1014	1ST OF 3 SOLIDS	2/ 9/14/ 0/5/0	CLEAR	1.2500	1.0638	0.9259	0.8197	0.8772	0.8475	0.7692	0.7246	0.6250
1014	2ND OF 3 SOLIDS	2/ 9/16/ 0/5/0	CLEAR	1.1905	1.0870	0.8772	0.7692	0.6667	0.6250	0.5051	0.3706	0.2404
1014	3RD OF 3 SOLIDS	2/ 5/16/ 0/3/0	8.130	1.0870	0.9259	0.7143	0.5051	0.0865	0.0000	0.0000	0.0000	0.0000
33	1ST OF 4 SOLIDS	1/ 3/ 4/ 1/1/0	CLEAR	0.0000	0.0000	0.0000	0.0000	0.0000	0.0000	0.0000	0.0000	0.0000
33	2ND OF 4 SOLIDS	1/ 4/ 4/ 1/1/0	CLEAR	0.0000	0.0000	0.0000	0.0000	0.0000	0.0000	0.0000	0.0000	0.0000
33	3RD OF 4 SOLIDS	1/ 7/ 2/ 1/1/0	CLEAR	0.0000	0.0000	0.0000	0.0000	0.0000	0.0000	0.0000	0.0000	0.0000
33	4TH OF 4 SOLIDS	2/15/15/ 0/3/0	10.590	1.1564	1.0000	0.7463	0.7576	0.7692	0.6579	0.5376	0.2564	0.0000
82	1ST OF 4 SOLIDS	2/ 5/15/ 0/3/0	CLEAR	1.1628	1.1364	0.9434	0.8772	0.8333	0.8675	0.8621	0.7576	0.7246
82	2ND OF 4 SOLIDS	2/11/15/ 0/3/0	CLEAR	1.1111	1.1364	0.9091	0.8772	0.8621	0.8065	0.8621	0.7576	0.6757
82	3RD OF 4 SOLIDS	2/ 5/15/ 0/3/0	CLEAR	1.0870	1.1111	0.8929	0.7937	0.7813	0.7813	0.7813	0.6494	0.5682
82	4TH OF 4 SOLIDS	2/ 4/15/ 0/3/0	CLEAR	1.0417	0.9434	0.6250	0.4834	0.3706	0.3247	0.2874	0.2222	0.1244
204	1ST OF 4 SOLIDS	1/ 3/ 4/ 1/2/0	CLEAR	1.0204	1.1111	1.0204	0.9615	0.8065	0.8772	0.8475	0.7246	0.6579
204	2ND OF 4 SOLIDS	1/ 3/ 4/ 1/2/0	CLEAR	1.1905	1.2500	0.9804	0.8475	0.8475	0.8333	0.8772	0.7246	0.6579
204	3RD OF 4 SOLIDS	2/ 5/13/ 0/3/0	CLEAR	1.0204	1.0638	0.8929	0.8929	0.8772	0.7937	0.7692	0.6494	0.5618
204	4TH OF 4 SOLIDS	2/ 5/15/ 0/3/0	CLEAR	1.0000	1.0870	0.8621	0.8333	0.7813	0.7143	0.6757	0.5682	0.5000
379	1ST OF 4 SOLIDS	2/11/15/ 0/3/0	CLEAR	1.1111	1.0417	1.0204	0.8772	0.7937	0.8772	0.8065	0.6944	0.5814
379	2ND OF 4 SOLIDS	2/ 7/15/ 0/3/0	CLEAR	1.2195	1.1111	0.9259	0.8333	0.8333	0.8621	0.7663	0.6494	0.5155
379	3RD OF 4 SOLIDS	2/ 5/15/ 0/3/0	CLEAR	1.2821	1.0638	0.8333	0.8621	0.7692	0.7143	0.5882	0.4673	0.2941
379	4TH OF 4 SOLIDS	2/ 7/16/ 0/5/0	7.130	1.1564	0.9615	0.7143	0.4065	0.0000	0.0000	0.0000	0.0000	0.0000
400	1ST OF 4 SOLIDS	1/ 0/ 0/22/1/0	CLEAR	0.0000	0.0000	0.0000	0.0000	0.0000	0.0000	0.0000	0.0000	0.0000
400	2ND OF 4 SOLIDS	1/ 5/ 4/ 1/2/0	CLEAR	1.1905	1.1364	1.0000	0.9804	0.8929	0.8065	0.7463	0.7353	0.7353
400	3RD OF 4 SOLIDS	2/ 7/14/ 0/3/0	CLEAR	1.2500	1.0638	0.9615	0.8065	0.7813	0.8475	0.7692	0.7143	0.6944
400	4TH OF 4 SOLIDS	1/ 0/ 0/21/1/0	CLEAR	0.0000	0.0000	0.0000	0.0000	0.0000	0.0000	0.0000	0.0000	0.0000
503	1ST OF 4 SOLIDS	1/ 4/ 4/ 1/1/0	CLEAR	1.5158	1.0638	0.9804	1.0000	0.9434	0.9091	0.8772	0.7813	0.8475
503	2ND OF 4 SOLIDS	1/ 4/ 4/ 1/1/0	CLEAR	1.2821	1.1364	0.9615	0.9804	0.9259	0.8772	0.8333	0.8065	0.7937
503	3RD OF 4 SOLIDS	2/ 5/14/ 0/3/0	CLEAR	1.2195	0.9615	0.9091	0.8475	0.8621	0.8333	0.7813	0.7353	0.6173
503	4TH OF 4 SOLIDS	2/ 5/14/ 0/3/0	CLEAR	1.1111	1.0204	0.8929	0.8621	0.8675	0.8197	0.7937	0.7143	0.6410
515	1ST OF 4 SOLIDS	2/ 9/14/ 0/3/0	CLEAR	1.0870	1.0870	0.9804	0.9259	1.0204	1.0204	0.9615	0.8065	0.7042
515	2ND OF 4 SOLIDS	2/ 7/14/ 0/3/0	CLEAR	1.1564	1.0638	0.9259	0.9804	1.0000	1.0000	0.9091	0.7576	0.7143
515	3RD OF 4 SOLIDS	2/11/14/ 0/3/0	CLEAR	1.1628	1.0638	0.8197	0.7246	0.6329	0.5495	0.3817	0.2688	0.1488
515	4TH OF 4 SOLIDS	2/11/14/ 0/3/0	CLEAR	1.1628	1.0417	0.8475	0.7576	0.6849	0.4717	0.3817	0.2041	0.1629
522	1ST OF 4 SOLIDS	1/ 0/ 0/14/1/0	CLEAR	0.8929	0.8475	0.9259	0.8929	1.0638	1.0638	0.6667	0.6667	0.9804
522	2ND OF 4 SOLIDS	1/ 4/ 5/ 1/1/0	CLEAR	0.8475	1.0204	0.9091	0.9259	0.9091	0.8621	0.7937	0.7353	0.8772
522	3RD OF 4 SOLIDS	1/ 0/ 0/15/1/0	CLEAR	0.8772	1.0000	0.9259	0.8621	0.8772	0.8772	0.7692	0.7353	0.7042
522	4TH OF 4 SOLIDS	2/ 7/14/ 0/3/0	CLEAR	1.1111	0.9615	0.9615	0.8675	0.7813	0.7937	0.7143	0.6250	0.5376
695	1ST OF 4 SOLIDS	1/ 2/ 4/ 1/2/0	CLEAR	1.1628	1.0638	0.9259	0.8475	0.8475	0.8929	0.8475	0.8065	0.7937
695	2ND OF 4 SOLIDS	1/ 3/ 6/ 1/2/0	CLEAR	1.1628	1.0638	0.9259	0.7937	0.7463	0.8333	0.7143	0.6410	0.2370
695	3RD OF 4 SOLIDS	2/ 9/14/ 0/3/0	CLEAR	1.0870	1.0204	0.8772	0.8772	0.8065	0.8675	0.7353	0.6410	0.2193
695	4TH OF 4 SOLIDS	2/ 7/14/ 0/3/0	CLEAR	1.0638	0.9634	0.8333	0.6494	0.4902	0.3566	0.1825	0.1661	0.1724
697	1ST OF 4 SOLIDS	1/ 7/ 8/ 1/2/0	CLEAR	1.0870	0.9804	0.9434	0.8065	0.7463	0.8675	0.6667	0.5376	0.3623
697	2ND OF 4 SOLIDS	1/ 5/ 8/ 1/2/0	CLEAR	0.9091	0.9804	0.8333	0.7463	0.7353	0.6667	0.5376	0.4063	0.2381
697	3RD OF 4 SOLIDS	1/ 0/ 0/12/2/0	CLEAR	0.0000	0.0000	0.0000	0.0000	0.0000	0.0000	0.0000	0.0000	0.0000
697	4TH OF 4 SOLIDS	2/ 5/16/ 0/5/0	5.130	0.6024	0.1865	0.0000	0.0000	0.0000	0.0000	0.0000	0.0000	0.0000
769	1ST OF 4 SOLIDS	1/ 0/ 0/22/2/0	CLEAR	0.0000	0.0000	0.0000	0.0000	0.0000	0.0000	0.0000	0.0000	0.0000
769	2ND OF 4 SOLIDS	1/ 4/ 6/ 1/2/0	CLEAR	1.1111	1.0000	0.8929	0.9091	0.8621	0.8065	0.7463	0.6329	0.5635
769	3RD OF 4 SOLIDS	2/ 9/14/ 0/3/0	CLEAR	1.1111	1.0000	0.8929	0.9091	0.8621	0.8065	0.7463	0.6329	0.5635
769	4TH OF 4 SOLIDS	1/ 4/ 6/ 1/2/0	CLEAR	1.1111	1.1111	0.9434	0.8675	0.7937	0.8675	0.7246	0.6173	0.5682
854	1ST OF 4 SOLIDS	1/ 0/ 0/23/1/0	CLEAR	1.5152	1.1628	0.8621	1.0638	0.7353	0.7353	0.7813	0.9615	0.7813
854	2ND OF 4 SOLIDS	1/ 4/ 6/ 1/2/0	CLEAR	1.1905	1.0870	0.9804	0.9804	0.5952	1.1628	0.7692	0.7246	0.6329
854	3RD OF 4 SOLIDS	2/12/14/ 0/3/0	CLEAR	1.1905	1.0417	0.8621	0.8065	0.7813	0.7246	0.6329	0.5882	0.4673

932	5TH OF 7 SOLIDS	1/ 5/ 4/ 1/2/0	5.130	1.0870	0.8929	0.0000	0.0000	0.0000	0.0000	0.0000	0.0000	0.0000	0.0000
932	6TH OF 7 SOLIDS	1/ 5/ 4/ 1/2/0	5.130	1.0870	0.8929	0.0000	0.0000	0.0000	0.0000	0.0000	0.0000	0.0000	0.0000
932	7TH OF 7 SOLIDS	2/16/15/ 0/5/0	4.130	0.7553	0.0000	0.0000	0.0000	0.0000	0.0000	0.0000	0.0000	0.0000	0.0000

COMPUTER CHECK NO. 1500

A3 - 2 Comp. Check No. 1600, Female Branch-Line Installation (W.C.2),
Gradient 1:150.

GREENWICH DISTRICT HOSPITAL, ON SITE
MONITORING OF ABOVE GROUND DRAINAGE.
DR. J. A. SWAFFIELD AND MR. S. D. BOKCR.
DRAINAGE RESEARCH GROUP, - DEPARTMENT OF
BUILDING TECHNOLOGY - BRUNEL UNIVERSITY.

ORANGE W.C. SUITE GRADIENT = 1:150.
FEMALE SUITE OF W.C. S.

NUMBER OF RUNS UNDER COMPARISON = 438 .

VELOCITY MEASUREING POINT.
DISTANCE (M) FROM W.C. 1 2 3 4 5 6 7 8 9
SENSOR SEPARATION (M) . 1.0 1.0 1.0 1.0 1.0 1.0 1.0 1.0 1.0

RUN NO.	RELATIVE PUSN. SOLID IN FLUSH.	CLASSIFICATION NO. OF SOLID.	STOP POSN.	VELOCITY, M/S.								
6	NO OTHER SOLID	2/10/14/	0/3/0 CLEAR	0.9615	0.9259	0.8065	0.8475	0.8333	0.7463	0.7353	0.6024	0.5495
11	NO OTHER SOLID	1/ 0/ 0/22/1/0	CLEAR	1.3158	1.1905	1.1111	0.9615	0.9091	0.8929	0.8772	0.7266	0.7463
14	NO OTHER SOLID	2/ 9/14/	0/3/0 CLEAR	0.8772	0.9091	0.8475	0.8065	0.8065	0.7266	0.6944	0.6494	0.5882
17	NO OTHER SOLID	2/ 7/12/	0/3/0 CLEAR	0.8621	0.9259	0.7692	0.7266	0.6667	0.6250	0.6098	0.4425	0.3968
29	NO OTHER SOLID	2/11/14/	0/3/0 CLEAR	0.9434	1.0000	0.7937	0.7937	0.7937	0.7463	0.6694	0.5747	0.5618
34	NO OTHER SOLID	2/ 6/14/	0/3/0 CLEAR	0.9091	1.0638	0.8929	0.8475	0.8065	0.7813	0.8475	0.7042	0.6410
43	NO OTHER SOLID	2/13/14/	0/3/0 CLEAR	0.9091	0.9804	0.9091	0.8197	0.7692	0.7353	0.7463	0.6494	0.6494
45	NO OTHER SOLID	2/10/16/	0/3/0 CLEAR	0.8333	0.8929	0.7937	0.7463	0.6024	0.5635	0.4065	0.2591	0.2146
49	NO OTHER SOLID	2/ 7/13/	0/3/0 CLEAR	1.0204	1.0638	0.8772	0.8929	0.8197	0.7813	0.8475	0.7042	0.7266
54	NO OTHER SOLID	2/ 7/14/	0/3/0 CLEAR	0.9091	1.0638	0.8929	0.8621	0.7576	0.7692	0.7576	0.7266	0.6410
61	NO OTHER SOLID	6/11/14/	0/5/0 6.070	0.7463	0.7353	0.5051	0.0000	0.0000	0.0000	0.0000	0.0000	0.0000
68	NO OTHER SOLID	6/11/15/	0/4/0 CLEAR	0.8929	0.9615	0.7353	0.7266	0.6757	0.5556	0.5000	0.3497	0.2809
70	NO OTHER SOLID	2/ 9/14/	0/3/0 CLEAR	0.8929	0.9615	0.8333	0.7692	0.7813	0.7062	0.6694	0.5495	0.4902
73	NO OTHER SOLID	2/ 7/13/	0/3/0 CLEAR	0.8929	1.0000	0.8621	0.8197	0.8065	0.7692	0.7463	0.6579	0.6494
77	NO OTHER SOLID	2/ 9/14/	0/3/0 CLEAR	0.9091	0.9434	0.8065	0.6757	0.6944	0.6694	0.5882	0.4425	0.3731
79	NO OTHER SOLID	2/ 9/13/	0/3/0 CLEAR	0.9091	0.9615	0.8065	0.7576	0.7163	0.6879	0.6610	0.5693	0.5102
83	NO OTHER SOLID	2/ 7/12/	0/3/0 CLEAR	1.0000	1.0638	0.8621	0.8197	0.8197	0.8333	0.8197	0.6944	0.6944
89	NO OTHER SOLID	2/ 5/16/	0/3/0 CLEAR	0.8475	0.8772	0.7353	0.6694	0.6024	0.5263	0.4368	0.2747	0.2674
90	NO OTHER SOLID	2/ 5/15/	0/3/0 CLEAR	0.8929	0.9091	0.7813	0.7353	0.7463	0.6173	0.5682	0.4808	0.4098
95	NO OTHER SOLID	2/11/13/	0/3/0 CLEAR	0.8929	0.9434	0.7376	0.6667	0.6757	0.6494	0.6230	0.4717	0.4310
97	NO OTHER SOLID	2/13/13/	0/3/0 10.710	0.7576	0.8197	0.6329	0.5882	0.3817	0.1845	0.1044	0.0000	0.0000

100	NO OTHER SOLID	2/11/13/	0/3/0	CLEAR	0.9259	0.9434	0.8475	0.7937	0.7692	0.7266	0.7353	0.6098	0.5618
101	NO OTHER SOLID	2/ 7/15/	0/3/0	CLEAR	0.9434	0.8772	0.7937	0.7266	0.6579	0.6250	0.5682	0.4762	0.4202
102	NO OTHER SOLID	2/11/13/	0/3/0	CLEAR	0.9091	2.2727	0.8475	0.8197	0.7463	0.6737	0.7266	0.6173	0.5747
107	NO OTHER SOLID	2/ 6/15/	0/3/0	CLEAR	0.8929	0.9615	0.8065	0.7813	0.7353	0.6869	0.6329	0.5376	0.4808
109	NO OTHER SOLID	2/ 9/15/	0/3/0	CLEAR	0.9091	1.0000	0.8197	0.8065	0.7576	0.6944	0.6379	0.5747	0.5376
126	NO OTHER SOLID	2/15/14/	0/3/0	CLEAR	0.8929	1.0000	0.7937	0.7576	0.7143	0.6410	0.6667	0.5952	0.5747
128	NO OTHER SOLID	2/10/14/	0/3/0	CLEAR	0.8197	1.0000	0.8475	0.7353	0.7143	0.6410	0.6250	0.5618	0.5208
130	NO OTHER SOLID	2/15/14/	0/3/0	CLEAR	0.8197	0.9259	0.7813	0.8065	0.6944	0.6737	0.6579	0.6026	0.5882
132	NO OTHER SOLID	2/ 5/13/	0/5/0	CLEAR	0.8772	0.8929	0.7692	0.7266	0.6944	0.6024	0.5618	0.4348	0.3876
134	NO OTHER SOLID	2/ 7/14/	0/3/0	CLEAR	0.9615	1.0204	0.8475	0.8475	0.7353	0.7266	0.7692	0.6494	0.6024
144	NO OTHER SOLID	2/ 9/14/	0/3/0	CLEAR	0.7576	0.9804	0.8065	0.7813	0.7266	0.6667	0.6250	0.5635	0.5051
146	NO OTHER SOLID	2/ 7/14/	0/3/0	CLEAR	0.9259	0.9804	0.8333	0.7692	0.7937	0.7143	0.6737	0.6026	0.5635
150	NO OTHER SOLID	2/11/14/	0/3/0	CLEAR	0.9804	1.0870	0.8621	0.8197	0.7937	0.7376	0.7813	0.6410	0.6098
156	NO OTHER SOLID	5/11/14/	18/1/5	CLEAR	0.8197	1.0870	0.8772	0.6579	0.7353	0.6173	0.5265	0.3876	0.3546
163	NO OTHER SOLID	2/ 5/14/	0/3/0	CLEAR	0.8772	0.9804	0.7692	0.7576	0.7813	0.7143	0.6757	0.6173	0.6098
166	NO OTHER SOLID	3/19/	0/33/3/0	CLEAR	0.9615	1.0417	0.8333	0.8475	0.8065	0.7937	0.7463	0.7042	0.6494
167	NO OTHER SOLID	2/ 4/14/	0/3/0	CLEAR	0.8929	0.9615	0.8475	0.7463	0.8197	0.6944	0.8772	0.6098	0.5319
175	NO OTHER SOLID	3/17/	0/53/4/0	CLEAR	0.9259	1.0204	0.8621	0.7813	0.8065	0.7463	0.7353	0.7143	0.6944
181	NO OTHER SOLID	4/ 0/	0/33/0/0	CLEAR	0.8621	0.9804	0.8333	0.7353	0.6757	0.6329	0.5319	0.4237	0.3472
189	NO OTHER SOLID	2/ 5/15/	0/3/0	CLEAR	0.8772	0.9091	0.8065	0.6944	0.6849	0.6379	0.6098	0.4808	0.4202
196	NO OTHER SOLID	2/ 6/15/	0/3/0	CLEAR	0.9615	1.0000	0.7692	0.7692	0.7692	0.7376	0.7692	0.6757	0.6494
202	NO OTHER SOLID	2/11/13/	0/3/0	CLEAR	0.9259	1.0638	0.8929	0.8929	0.8065	0.7376	0.8065	0.7813	0.7143
210	NO OTHER SOLID	2/11/14/	0/3/0	CLEAR	0.8929	0.9804	0.8065	0.7813	0.7463	0.6944	0.6757	0.5952	0.5102
230	NO OTHER SOLID	2/ 6/15/	0/3/0	CLEAR	0.9091	1.0000	0.8621	0.8621	0.7937	0.7463	0.8333	0.7042	0.6849
234	NO OTHER SOLID	2/ 7/14/	0/4/0	CLEAR	0.8065	0.9615	0.7937	0.6737	0.7042	0.6494	0.6098	0.5000	0.4032
240	NO OTHER SOLID	2/ 4/15/	0/3/0	CLEAR	0.9091	0.9804	0.7937	0.7692	0.7463	0.7143	0.7143	0.6024	0.5635
245	NO OTHER SOLID	2/ 4/14/	0/3/0	CLEAR	0.8475	0.9804	0.8333	0.8197	0.7813	0.7813	0.7692	0.6849	0.6494
246	NO OTHER SOLID	2/ 9/15/	0/3/0	CLEAR	0.8197	0.8772	0.7042	0.5682	0.4310	0.3906	0.6368	0.4098	0.3937
248	NO OTHER SOLID	2/ 6/13/	0/3/0	CLEAR	0.9091	1.0000	0.7576	0.7692	0.7976	0.7143	0.7463	0.6098	0.5682
250	NO OTHER SOLID	4/ 0/	0/32/0/0	CLEAR	0.9434	1.0000	0.8621	0.8065	0.7246	0.7576	0.8065	0.7143	0.6667
259	NO OTHER SOLID	2/ 4/15/	0/3/0	CLEAR	0.8621	1.0000	0.8065	0.7353	0.7813	0.7353	0.7353	0.6250	0.5556
261	NO OTHER SOLID	2/ 6/14/	0/3/0	CLEAR	0.8621	0.9259	0.8333	0.7813	0.7143	0.6849	0.6944	0.5618	0.5208
263	NO OTHER SOLID	2/ 6/14/	0/3/0	CLEAR	0.9434	1.0000	0.7937	0.7266	0.7813	0.7143	0.7246	0.6849	0.6024

409	NO OTHER SOLID	2/ 5/15/ 0/5/0	CLEAR	0.9259	0.8197	0.7937	0.6944	0.6757	0.6667	0.5814	0.5051	0.6717
413	NO OTHER SOLID	3/17/ 0/53/0/0	CLEAR	0.9434	0.8475	0.9615	0.8197	0.7353	0.7813	0.7463	0.6579	0.5747
437	NO OTHER SOLID	2/ 5/16/ 0/3/0	CLEAR	1.0638	1.0638	0.8929	0.8621	0.8333	0.8621	0.7813	0.7576	0.7576
440	NO OTHER SOLID	2/ 9/14/ 0/3/0	CLEAR	1.0417	0.9434	0.8772	0.8065	0.7353	0.7353	0.7576	0.6667	0.6173
443	NO OTHER SOLID	2/11/16/ 0/3/0	CLEAR	1.0204	0.9615	0.8475	0.7813	0.7813	0.7576	0.7463	0.7042	0.6849
447	NO OTHER SOLID	2/11/14/ 0/3/0	CLEAR	0.9804	0.9615	0.8621	0.8621	0.8065	0.7813	0.7463	0.7163	0.7163
450	NO OTHER SOLID	2/11/14/ 0/3/0	CLEAR	1.0204	0.9259	0.8621	0.7576	0.8475	0.7353	0.7576	0.7042	0.6849
453	NO OTHER SOLID	2/ 5/16/ 0/5/0	CLEAR	0.8333	0.8772	0.6667	0.5882	0.5000	0.4587	0.4545	0.3521	0.3067
455	NO OTHER SOLID	2/ 7/14/ 0/3/0	CLEAR	0.8929	0.8929	0.6579	0.6024	0.5000	0.4386	0.3676	0.2890	0.3401
456	NO OTHER SOLID	2/ 7/14/ 0/3/0	CLEAR	0.9091	0.9091	0.7813	0.7266	0.7463	0.7353	0.6944	0.5435	0.4950
457	NO OTHER SOLID	2/ 4/15/ 0/5/0	5.645	0.5747	0.3049	0.0000	0.0000	0.0000	0.0000	0.0000	0.0000	0.0000
464	NO OTHER SOLID	2/ 7/15/ 0/3/0	CLEAR	0.9434	0.8772	0.7266	0.7062	0.6667	0.6757	0.5618	0.4000	0.3268
466	NO OTHER SOLID	2/10/15/ 0/3/0	CLEAR	0.9259	0.8929	0.8197	0.7813	0.7463	0.7143	0.6329	0.5814	0.4762
467	NO OTHER SOLID	5/11/15/20/5/3	CLEAR	1.1364	1.0000	0.9259	0.7813	0.7813	0.7937	0.7813	0.7463	0.6849
470	NO OTHER SOLID	2/ 5/16/ 0/5/0	CLEAR	1.1111	0.9434	0.7576	0.5814	0.4000	0.2646	0.2358	0.2294	0.2183
472	NO OTHER SOLID	2/11/14/ 0/3/0	CLEAR	0.9434	0.8929	0.8197	0.7463	0.6944	0.6944	0.6024	0.3731	0.3546
476	NO OTHER SOLID	2/12/14/ 0/3/0	CLEAR	0.9091	0.8065	0.8333	0.7692	0.6410	0.6329	0.6173	0.5495	0.4386
478	NO OTHER SOLID	2/ 5/14/ 0/3/0	CLEAR	0.9259	0.8772	0.8475	0.7813	0.6944	0.7062	0.6250	0.5495	0.4587
491	NO OTHER SOLID	2/ 5/14/ 0/3/0	CLEAR	0.9259	0.8621	0.8621	0.8197	0.7576	0.7937	0.7813	0.6667	0.6329
498	NO OTHER SOLID	2/ 7/14/ 0/3/0	CLEAR	1.0417	1.0000	0.9091	0.7937	0.7143	0.8065	0.7937	0.7813	0.6667
500	NO OTHER SOLID	2/ 7/16/ 0/3/0	CLEAR	0.9091	0.8621	0.8333	0.7062	0.6667	0.6098	0.4464	0.3401	0.2890
505	NO OTHER SOLID	2/ 5/14/ 0/3/0	CLEAR	1.0000	1.0638	0.9091	0.8197	0.8197	0.8675	0.8065	0.7576	0.7143
507	NO OTHER SOLID	2/ 7/14/ 0/3/0	CLEAR	1.0870	0.9804	0.9615	0.8065	0.8197	0.7576	0.8333	0.7143	0.7143
510	NO OTHER SOLID	2/ 5/16/ 0/3/0	CLEAR	0.9434	0.8772	0.8333	0.7576	0.7353	0.7143	0.6250	0.5376	0.4950
512	NO OTHER SOLID	2/ 7/14/ 0/5/0	CLEAR	0.9091	0.8929	0.8197	0.7576	0.7266	0.7042	0.6579	0.5618	0.5051
515	NO OTHER SOLID	2/ 7/16/ 0/5/0	CLEAR	0.9091	0.9259	0.7813	0.7576	0.7692	0.7463	0.7062	0.6329	0.5747
517	NO OTHER SOLID	2/ 7/15/ 0/3/0	CLEAR	1.0204	1.0204	0.8475	0.8197	0.8065	0.7692	0.7463	0.7353	0.6849
527	NO OTHER SOLID	2/ 5/16/ 0/3/0	CLEAR	0.9091	0.9804	0.7813	0.7692	0.7576	0.7692	0.7463	0.6494	0.5682
530	NO OTHER SOLID	2/ 5/16/ 0/3/0	CLEAR	1.0000	0.9804	0.8475	0.7576	0.7576	0.8621	0.7692	0.7246	0.6757
531	NO OTHER SOLID	2/ 7/14/ 0/3/0	CLEAR	1.0204	0.9804	0.8621	0.8475	0.8065	0.7937	0.7692	0.6757	0.6849
536	NO OTHER SOLID	2/ 7/14/ 0/3/0	CLEAR	0.9259	0.9259	0.8197	0.7692	0.7143	0.7463	0.6757	0.6250	0.5682
542	NO OTHER SOLID	2/10/14/ 0/5/0	CLEAR	0.8621	0.8197	0.7937	0.6667	0.6098	0.5102	0.4274	0.3289	0.2732
544	NO OTHER SOLID	2/11/14/ 0/3/0	CLEAR	0.8929	0.8929	0.8065	0.7813	0.7266	0.7042	0.6098	0.5435	0.4762

549	NO OTHER SOLID	2/11/15/ 0/3/0	CLEAR	0.9434	0.8772	0.8065	0.7692	0.7062	0.6966	0.6579	0.5952	0.5263
555	NO OTHER SOLID	2/ 7/14/ 0/3/0	CLEAR	1.0000	0.9615	0.9091	0.8772	0.8197	0.7813	0.7937	0.7463	0.6869
556	NO OTHER SOLID	2/ 7/14/ 0/3/0	CLEAR	1.0000	0.9804	0.8065	0.8333	0.7692	0.7813	0.7143	0.6579	0.6579
558	NO OTHER SOLID	2/ 5/15/ 0/3/0	CLEAR	0.8621	0.8772	0.7937	0.7463	0.7143	0.6869	0.6329	0.5682	0.5263
559	NO OTHER SOLID	2/ 9/14/ 0/3/0	CLEAR	0.9259	0.8621	0.8333	0.8197	0.7143	0.7463	0.6173	0.5635	0.5263
569	NO OTHER SOLID	2/ 7/15/ 0/3/0	CLEAR	1.0638	1.0204	0.8197	0.7813	0.7813	0.7937	0.7813	0.6869	0.6410
576	NO OTHER SOLID	3/18/ 0/5/13/0	CLEAR	1.0638	0.9615	0.9091	0.6869	0.6757	0.7692	0.7692	0.7353	0.6173
577	NO OTHER SOLID	2/ 7/14/ 0/3/0	CLEAR	0.9434	0.9259	0.8772	0.8065	0.7692	0.7576	0.7042	0.6944	0.6250
584	NO OTHER SOLID	2/ 5/14/ 0/3/0	CLEAR	0.8475	0.9259	0.8333	0.7143	0.7353	0.7376	0.6944	0.6250	0.5376
585	NO OTHER SOLID	3/18/ 0/5/3/3/0	CLEAR	1.0870	1.0638	0.9091	0.8475	0.8621	0.8197	0.7576	0.7266	0.7463
589	NO OTHER SOLID	2/ 4/14/ 0/3/0	CLEAR	0.9091	0.8929	0.8065	0.7266	0.6579	0.6024	0.5618	0.5208	0.4348
591	NO OTHER SOLID	2/12/15/ 0/3/0	CLEAR	0.9615	0.9434	0.8065	0.7463	0.7266	0.7353	0.6250	0.5814	0.5376
593	NO OTHER SOLID	3/18/ 0/5/1/3/0	CLEAR	1.0000	0.8929	0.8197	0.8333	0.8333	0.7937	0.7692	0.7042	0.6694
595	NO OTHER SOLID	2/ 5/14/ 0/3/0	CLEAR	0.9804	0.8065	0.8197	0.8065	0.7692	0.7463	0.7246	0.6098	0.5747
599	NO OTHER SOLID	2/15/16/ 0/5/0	6.570	0.7353	0.6757	0.3968	0.0000	0.0000	0.0000	0.0000	0.0000	0.0000
605	NO OTHER SOLID	2/ 6/14/ 0/3/0	CLEAR	0.9259	0.9259	0.7692	0.7813	0.7353	0.7266	0.6944	0.6024	0.5000
617	NO OTHER SOLID	2/ 7/14/ 0/3/0	CLEAR	1.0000	0.8475	0.8475	0.8333	0.8621	0.8197	0.7463	0.7143	0.6757
618	NO OTHER SOLID	3/18/ 0/5/2/3/0	11.480	0.7937	0.7042	0.6757	0.5376	0.3289	0.2155	0.1548	0.1199	0.0000
626	NO OTHER SOLID	2/ 4/14/ 0/3/0	CLEAR	1.0638	0.9615	0.9434	0.8065	0.7692	0.8333	0.7246	0.7353	0.6329
627	NO OTHER SOLID	2/ 7/14/ 0/3/0	CLEAR	0.9804	0.9091	0.8475	0.8065	0.7937	0.7576	0.7143	0.6757	0.5882
632	NO OTHER SOLID	3/18/ 0/5/3/3/0	CLEAR	1.0204	0.8772	0.8475	0.8197	0.8197	0.8065	0.7353	0.7143	0.6667
633	NO OTHER SOLID	2/ 6/14/ 0/3/0	CLEAR	0.8621	0.8621	0.8621	0.7692	0.7266	0.7042	0.6098	0.5682	0.4854
644	NO OTHER SOLID	2/ 7/14/ 0/3/0	CLEAR	0.8333	0.7937	0.7042	0.6173	0.5635	0.5155	0.4425	0.3846	0.3759
646	NO OTHER SOLID	2/ 6/14/ 0/3/0	CLEAR	0.8772	0.8772	0.7813	0.7266	0.6964	0.6630	0.4545	0.3597	0.3247
647	NO OTHER SOLID	2/ 4/14/ 0/3/0	CLEAR	0.9615	0.8772	0.8197	0.7463	0.7266	0.7353	0.6667	0.5618	0.4673
650	NO OTHER SOLID	2/11/15/ 0/3/0	CLEAR	0.9259	0.8621	0.7692	0.7576	0.6694	0.5814	0.5051	0.4587	0.3731
658	NO OTHER SOLID	2/ 7/14/ 0/3/0	CLEAR	0.8929	0.9259	0.7813	0.7692	0.7143	0.7143	0.6098	0.5376	0.5155
661	NO OTHER SOLID	2/ 9/14/ 0/3/0	CLEAR	0.9259	0.9259	0.8475	0.7463	0.6869	0.6757	0.6610	0.5747	0.5208
664	NO OTHER SOLID	2/11/12/ 0/3/0	CLEAR	0.8621	0.9259	0.8929	0.8197	0.7663	0.7576	0.7266	0.6410	0.5882
667	NO OTHER SOLID	2/12/15/ 0/3/0	CLEAR	0.9091	0.8772	0.8333	0.7813	0.7163	0.6579	0.6694	0.5000	0.6000
673	NO OTHER SOLID	2/ 5/14/ 0/3/0	CLEAR	0.9259	0.8929	0.8675	0.7937	0.7266	0.7813	0.6944	0.6250	0.5682
674	NO OTHER SOLID	2/ 7/15/ 0/5/0	CLEAR	1.0000	0.8772	0.9091	0.8197	0.7937	0.7937	0.7692	0.6944	0.6024
675	NO OTHER SOLID	2/11/14/ 0/5/0	12.530	0.8475	0.7813	0.6024	0.4762	0.2128	0.1563	0.1484	0.1235	0.0880

681	NO OTHER SOLID	2/ 7/14/ 0/3/0	CLEAR	0.9091	0.9091	0.8475	0.8065	0.7266	0.7266	0.6757	0.6410
690	NO OTHER SOLID	2/ 9/15/ 0/3/0	CLEAR	0.8772	0.8475	0.6944	0.6329	0.5319	0.4902	0.4032	0.3650
691	NO OTHER SOLID	2/ 7/14/ 0/5/0	CLEAR	0.8772	0.8475	0.8065	0.7266	0.6757	0.7163	0.6667	0.5208
693	NO OTHER SOLID	2/ 6/14/ 0/3/0	CLEAR	0.9804	0.9615	0.8675	0.8065	0.7937	0.7937	0.7463	0.5952
696	NO OTHER SOLID	2/ 5/14/ 0/3/0	CLEAR	0.9259	0.9434	0.9259	0.7353	0.7353	0.7692	0.7463	0.5952
704	NO OTHER SOLID	2/ 9/14/ 0/3/0	CLEAR	0.9091	0.8772	0.7692	0.7463	0.6757	0.6757	0.5747	0.4274
705	NO OTHER SOLID	2/ 9/14/ 0/5/0	CLEAR	0.9091	0.8475	0.7576	0.7576	0.6757	0.6494	0.5618	0.2762
713	NO OTHER SOLID	2/ 5/15/ 0/3/0	CLEAR	0.8475	0.8065	0.7353	0.6869	0.6329	0.5882	0.5208	0.3876
719	NO OTHER SOLID	2/ 5/16/ 0/5/0	CLEAR	0.8929	0.7692	0.6579	0.4310	0.2778	0.3106	0.2703	0.2551
725	NO OTHER SOLID	2/ 9/14/ 0/5/0	CLEAR	0.8772	0.8475	0.8333	0.7576	0.7042	0.7246	0.6329	0.5376
729	NO OTHER SOLID	2/ 7/15/ 0/3/0	CLEAR	0.8929	0.9091	0.8621	0.7463	0.7163	0.7246	0.6757	0.5319
730	NO OTHER SOLID	2/ 9/14/ 0/3/0	CLEAR	0.9259	0.8621	0.8333	0.7353	0.6869	0.5682	0.5376	0.3672
734	NO OTHER SOLID	2/ 9/15/ 0/5/0	CLEAR	0.9259	0.8333	0.7463	0.7163	0.7143	0.3012	0.2604	0.2119
740	NO OTHER SOLID	2/ 5/14/ 0/5/0	CLEAR	0.9434	0.8065	0.8197	0.7463	0.6667	0.6579	0.5376	0.4902
743	NO OTHER SOLID	2/11/14/ 0/3/0	CLEAR	0.9091	0.9804	0.9091	0.7813	0.7353	0.6944	0.6494	0.5102
744	NO OTHER SOLID	2/ 7/14/ 0/5/0	CLEAR	0.9259	0.8065	0.7813	0.7042	0.6250	0.6098	0.5556	0.4098
746	NO OTHER SOLID	2/12/14/ 0/5/0	CLEAR	0.9259	0.8772	0.8475	0.7692	0.7463	0.7042	0.6494	0.4545
750	NO OTHER SOLID	2/ 9/14/ 0/3/0	CLEAR	0.8621	0.8333	0.8065	0.7163	0.6250	0.5952	0.4854	0.3289
753	NO OTHER SOLID	2/ 5/16/ 0/3/0	CLEAR	0.8772	0.8621	0.7813	0.7353	0.7376	0.6869	0.6098	0.5319
754	NO OTHER SOLID	2/12/13/ 0/3/0	CLEAR	0.8475	0.9091	0.8621	0.7692	0.7042	0.7042	0.6329	0.4630
758	NO OTHER SOLID	2/ 4/15/ 0/3/0	CLEAR	0.8621	0.8333	0.7576	0.6494	0.5882	0.5618	0.4717	0.3788
760	NO OTHER SOLID	2/ 5/15/ 0/5/0	CLEAR	0.9091	0.8621	0.8065	0.7813	0.7463	0.7463	0.6250	0.4098
768	NO OTHER SOLID	2/ 7/16/ 0/3/0	CLEAR	0.9091	0.8772	0.7813	0.7246	0.6579	0.6757	0.6098	0.4132
770	NO OTHER SOLID	2/ 4/14/ 0/3/0	CLEAR	1.0204	0.9434	0.9434	0.8475	0.8065	0.8197	0.7353	0.6869
773	NO OTHER SOLID	1/ 5/ 5/ 1/2/0	CLEAR	0.0000	0.0000	0.0000	0.0000	0.0000	0.0000	0.0000	0.2747
779	NO OTHER SOLID	2/ 7/14/ 0/3/0	CLEAR	0.9091	0.9091	0.7246	0.7576	0.6757	0.6494	0.5556	0.4000
782	NO OTHER SOLID	2/11/14/ 0/3/0	CLEAR	0.8772	1.0204	0.8621	0.7937	0.7246	0.7692	0.7246	0.5952
794	NO OTHER SOLID	2/ 7/14/ 0/3/0	CLEAR	0.9804	0.8929	0.7692	0.7576	0.7576	0.7937	0.7937	0.6944
810	NO OTHER SOLID	2/ 7/14/ 0/3/0	CLEAR	0.9434	0.9434	0.8065	0.7163	0.7692	0.7576	0.7246	0.6494
815	NO OTHER SOLID	2/ 9/14/ 0/3/0	CLEAR	1.0000	0.9091	0.8475	0.8065	0.7692	0.7576	0.6667	0.5682
816	NO OTHER SOLID	2/ 7/14/ 0/5/0	CLEAR	0.9259	0.9615	0.8197	0.8197	0.7463	0.7937	0.7463	0.5952
830	NO OTHER SOLID	2/11/14/ 0/5/0	CLEAR	0.8929	0.8065	0.7246	0.6494	0.5882	0.4950	0.3650	0.2857
832	NO OTHER SOLID	2/ 9/14/ 0/3/0	CLEAR	0.9804	0.9091	0.8475	0.8065	0.7576	0.7663	0.7353	0.6667

837	NO OTHER SOLID	2/ 4/15/ 0/3/0	CLEAR	0.8772	0.7576	0.6098	0.4950	0.3937	0.3571	0.3521	0.3521	0.2907
851	NO OTHER SOLID	2/ 9/15/ 0/3/0	CLEAR	1.0000	0.9259	0.8333	0.8065	0.7463	0.7353	0.6667	0.6494	0.5814
894	NO OTHER SOLID	2/15/14/ 0/3/0	CLEAR	0.9615	0.8772	0.8065	0.8772	0.7937	0.7813	0.6494	0.6173	0.5682
896	NO OTHER SOLID	2/11/14/ 0/3/0	CLEAR	0.9091	0.9259	0.8475	0.8065	0.7042	0.7353	0.6494	0.6173	0.5618
898	NO OTHER SOLID	2/ 5/14/ 0/3/0	CLEAR	0.9091	0.9259	0.8333	0.7813	0.7353	0.7937	0.7143	0.6667	0.6098
899	NO OTHER SOLID	2/10/14/ 0/3/0	CLEAR	0.9434	0.9259	0.8065	0.8197	0.8065	0.7663	0.7353	0.6944	0.6494
902	NO OTHER SOLID	2/ 9/14/ 0/3/0	CLEAR	1.0417	0.9434	0.9259	0.8621	0.8065	0.8197	0.7353	0.7143	0.6944
904	NO OTHER SOLID	2/ 7/15/ 0/5/0	CLEAR	0.8333	0.8197	0.7463	0.7813	0.7143	0.6944	0.5263	0.5000	0.4274
908	NO OTHER SOLID	2/ 7/14/ 0/3/0	CLEAR	0.8772	0.7937	0.8065	0.6757	0.6098	0.4854	0.3759	0.2941	0.2762
910	NO OTHER SOLID	2/ 9/14/ 0/5/0	CLEAR	0.9804	0.8772	0.8197	0.8621	0.7692	0.7576	0.7042	0.7143	0.6173
911	NO OTHER SOLID	2/ 7/14/ 0/3/0	CLEAR	1.0204	1.0417	0.8621	0.8333	0.8197	0.7937	0.6944	0.7463	0.6849
912	NO OTHER SOLID	2/ 5/14/ 0/3/0	CLEAR	1.0204	1.0204	0.8621	0.8929	0.7937	0.8197	0.7246	0.7576	0.7937
918	NO OTHER SOLID	2/ 7/14/ 0/3/0	CLEAR	0.9615	0.8333	0.8197	0.8065	0.7813	0.7576	0.7143	0.6410	0.5682
920	NO OTHER SOLID	2/ 9/15/ 0/3/0	CLEAR	0.8929	0.8475	0.7246	0.7692	0.7663	0.6757	0.6098	0.5376	0.4505
923	NO OTHER SOLID	2/11/14/ 0/3/0	CLEAR	0.9259	0.8621	0.8197	0.8333	0.8065	0.7576	0.6494	0.6250	0.6024
925	NO OTHER SOLID	2/ 9/16/ 0/3/0	CLEAR	0.8475	0.8197	0.7813	0.7353	0.7143	0.5882	0.4808	0.4202	0.3268
929	NO OTHER SOLID	2/ 5/14/ 0/3/0	CLEAR	0.8929	0.8929	0.8333	0.7463	0.6944	0.6849	0.6250	0.5814	0.5000
930	NO OTHER SOLID	2/ 9/15/ 0/5/0	CLEAR	0.7692	0.6944	0.4425	0.2128	0.1089	0.1370	0.1712	0.1887	0.1779
931	NO OTHER SOLID	2/ 7/15/ 0/3/0	CLEAR	0.8475	0.8929	0.8475	0.7246	0.7463	0.7143	0.6410	0.5682	0.4902
933	NO OTHER SOLID	2/11/14/ 0/3/0	CLEAR	0.9259	0.9259	0.8065	0.8475	0.7937	0.7692	0.6329	0.6250	0.6173
937	NO OTHER SOLID	2/ 7/14/ 0/3/0	CLEAR	0.8929	0.7692	0.7143	0.6173	0.5051	0.4762	0.4202	0.3401	0.3311
942	NO OTHER SOLID	2/ 9/14/ 0/3/0	CLEAR	1.0417	1.0000	0.9615	0.8197	0.8197	0.7937	0.7692	0.7576	0.6944
947	NO OTHER SOLID	2/ 9/15/ 0/3/0	CLEAR	0.8929	0.9259	0.8197	0.7813	0.7463	0.7463	0.6757	0.6410	0.5814
950	NO OTHER SOLID	2/15/14/ 0/5/0	CLEAR	0.8929	0.9259	0.7576	0.7692	0.7353	0.7353	0.6494	0.6494	0.5952
965	NO OTHER SOLID	2/ 7/14/ 0/3/0	CLEAR	0.8475	0.8333	0.8333	0.7143	0.7042	0.6757	0.6173	0.5263	0.4902
969	NO OTHER SOLID	2/14/14/ 0/3/0	CLEAR	0.9259	0.9804	0.8333	0.8197	0.7692	0.7813	0.7143	0.7143	0.5882
979	NO OTHER SOLID	2/11/16/ 0/5/0	10.780	0.9091	0.8772	0.8475	0.8475	0.5263	0.4505	0.3321	0.0000	0.0000
982	NO OTHER SOLID	2/ 7/14/ 0/3/0	CLEAR	1.0638	1.0417	0.8197	0.7937	0.8929	0.7937	0.7813	0.7143	0.7042
983	NO OTHER SOLID	2/11/15/ 0/5/0	CLEAR	0.8621	0.8772	0.7813	0.7463	0.6667	0.6410	0.5495	0.4717	0.3937
986	NO OTHER SOLID	2/12/15/ 0/3/0	CLEAR	0.9259	0.8772	0.8475	0.8197	0.7813	0.7813	0.7246	0.7042	0.6757
993	NO OTHER SOLID	6/ 0/ 0/ 0/0/0	CLEAR	1.0000	0.9091	0.8333	0.8197	0.7692	0.7937	0.7353	0.7143	0.6329
997	NO OTHER SOLID	2/ 9/14/ 0/3/0	CLEAR	0.9615	0.9259	0.7813	0.8065	0.7692	0.8197	0.8065	0.7692	0.7143
1006	NO OTHER SOLID	2/ 7/14/ 0/3/0	CLEAR	0.8929	0.9259	0.8475	0.8333	0.8197	0.7813	0.7463	0.7813	0.7576

1012	NO OTHER SOLID	2/ 11/14/ 0/3/0	CLEAR	1.0204	0.9804	0.8621	0.8333	0.8063	0.8197	0.7246	0.7042	0.6944
1015	NO OTHER SOLID	2/ 5/16/ 0/3/0	CLEAR	0.0000	0.0000	0.0000	0.0000	0.0000	0.0000	0.4854	0.8333	0.7692
1017	NO OTHER SOLID	2/ 7/16/ 0/3/0	CLEAR	0.8621	0.9091	0.8475	0.7353	0.7042	0.7692	0.6667	0.5495	0.4808
1019	NO OTHER SOLID	2/ 9/14/ 0/3/0	CLEAR	0.8621	0.8772	0.7813	0.7246	0.5618	0.5495	0.4673	0.3937	0.3571
1021	NO OTHER SOLID	2/ 5/14/ 0/3/0	CLEAR	0.9259	0.9434	0.8772	0.7813	0.7246	0.7663	0.7143	0.6410	0.5814
1026	NO OTHER SOLID	2/11/14/ 0/3/0	CLEAR	0.9804	1.0204	0.8475	0.8333	0.8621	0.8063	0.7576	0.7353	0.6944
1031	NO OTHER SOLID	2/11/14/ 0/3/0	CLEAR	0.9615	1.0204	0.9259	0.8063	0.8197	0.7576	0.7463	0.7042	0.6667
1043	NO OTHER SOLID	2/ 7/14/ 0/5/0	CLEAR	0.8929	0.9259	0.8063	0.7463	0.7576	0.7576	0.7143	0.7143	0.6494
1056	NO OTHER SOLID	6/ 0/ 0/ 0/0/0 10.700		0.8475	0.8621	0.8197	0.7576	0.7042	0.6757	0.6950	0.0000	0.0000
85	1ST OF 2 SOLIDS	1/ 0/ 0/11/1/0	CLEAR	1.0000	1.1111	0.9091	0.9091	0.8333	0.7813	0.7692	0.7353	0.6944
85	2ND OF 2 SOLIDS	2/11/12/ 0/3/0	CLEAR	0.8929	0.9434	0.7576	0.7576	0.7042	0.6610	0.6250	0.4854	0.3906
110	1ST OF 2 SOLIDS	2/ 5/15/ 0/3/0	CLEAR	0.8929	0.8333	0.6944	0.7937	0.7463	0.6849	0.6849	0.6024	0.5376
110	2ND OF 2 SOLIDS	2/ 5/15/ 0/3/0	CLEAR	0.8333	0.9259	0.8333	0.7813	0.7246	0.6494	0.6849	0.5767	0.5051
114	1ST OF 2 SOLIDS	1/ 0/ 0/ 5/1/0	CLEAR	0.0000	0.0000	0.0000	0.0000	0.0000	0.0000	0.0000	0.0000	0.0000
114	2ND OF 2 SOLIDS	2/ 5/13/ 0/3/0	CLEAR	0.8065	0.8065	0.7042	0.6410	0.5263	0.4310	0.3731	0.2959	0.2660
138	1ST OF 2 SOLIDS	2/11/14/ 0/3/0 10.420		0.7246	0.9259	0.6757	0.6250	0.6717	0.3145	0.0000	0.0000	0.0000
158	2ND OF 2 SOLIDS	2/ 7/16/ 0/3/0 5.570		0.6944	0.6849	0.0000	0.0000	0.0000	0.0000	0.0000	0.0000	0.0000
159	1ST OF 2 SOLIDS	2/11/14/ 0/3/0	CLEAR	0.0000	0.0000	0.0000	0.0000	0.0000	0.0000	0.0000	0.0000	0.6757
159	2ND OF 2 SOLIDS	2/ 7/16/ 0/3/0	CLEAR	0.0000	0.0000	0.0000	0.8063	0.6173	0.6329	0.6944	0.5376	0.6250
148	1ST OF 2 SOLIDS	1/ 4/ 4/ 1/1/0	CLEAR	1.0000	1.1111	0.8333	0.7576	0.7246	0.7576	0.7042	0.5556	0.4854
148	2ND OF 2 SOLIDS	2/13/14/ 0/3/0	CLEAR	0.8621	0.8929	0.9615	0.5952	0.6667	0.6024	0.5747	0.4854	0.4257
159	1ST OF 2 SOLIDS	1/ 4/ 6/ 1/2/0	CLEAR	0.8621	0.9615	0.6379	0.6579	0.7692	0.6757	0.5747	0.4762	0.4310
159	2ND OF 2 SOLIDS	2/11/13/ 0/3/0	CLEAR	0.8772	0.9259	0.7813	0.7042	0.7042	0.6410	0.6173	0.4950	0.4348
184	1ST OF 2 SOLIDS	2/ 5/13/ 0/3/0	CLEAR	0.8621	0.9091	0.7937	0.7937	0.6667	0.6667	0.7143	0.5814	0.4902
184	2ND OF 2 SOLIDS	1/ 0/ 0/24/0/0	CLEAR	0.9434	0.8772	0.7937	0.7353	0.7143	0.6379	0.6173	0.4808	0.4098
199	1ST OF 2 SOLIDS	3/19/ 0/52/3/0	CLEAR	0.8065	0.8621	0.8621	0.7576	0.6667	0.6494	0.6329	0.5618	0.4854
199	2ND OF 2 SOLIDS	2/ 4/13/ 0/3/0	CLEAR	0.8621	0.9259	0.8772	0.7246	0.6329	0.6329	0.6250	0.5495	0.4717
226	1ST OF 2 SOLIDS	2/ 5/14/ 0/3/0	CLEAR	1.1905	1.3158	1.0638	1.0204	1.0417	1.0000	1.0204	0.9259	0.9091
226	2ND OF 2 SOLIDS	2/ 9/13/ 0/3/0	CLEAR	1.0870	1.2821	1.1428	1.1111	0.8772	0.9615	1.0204	0.8333	0.8621
239	1ST OF 2 SOLIDS	2/ 5/14/ 0/3/0	CLEAR	0.9091	0.9615	0.7813	0.7692	0.6667	0.6410	0.6329	0.4717	0.3846
239	2ND OF 2 SOLIDS	2/ 5/14/ 0/3/0	CLEAR	0.8772	0.8929	0.7937	0.6944	0.6757	0.6410	0.6024	0.5263	0.4000
281	1ST OF 2 SOLIDS	2/11/14/ 0/3/0	CLEAR	0.9434	0.9804	0.7813	0.7813	0.7492	0.7576	0.7266	0.6849	0.6098
281	2ND OF 2 SOLIDS	1/ 5/ 4/ 1/0/0 11.570		0.7692	0.8929	0.7463	0.7463	0.6944	0.6757	0.5682	0.3571	0.0000
330	1ST OF 2 SOLIDS	2/ 9/14/ 0/3/0	CLEAR	0.8929	0.8772	0.7692	0.7813	0.6944	0.7042	0.7143	0.5882	0.5208
330	2ND OF 2 SOLIDS	2/ 7/14/ 0/3/0	CLEAR	0.8065	0.8621	0.6379	0.5618	0.4543	0.4505	0.3676	0.2488	0.2994
351	1ST OF 2 SOLIDS	2/ 7/14/ 0/3/0	CLEAR	0.8929	0.8621	0.8197	0.7246	0.6379	0.6173	0.5952	0.4717	0.3846
351	2ND OF 2 SOLIDS	2/ 7/14/ 0/3/0	CLEAR	0.8475	0.8621	0.7937	0.6944	0.6250	0.6024	0.5814	0.4673	0.3876
358	1ST OF 2 SOLIDS	2/11/14/ 0/3/0	CLEAR	0.9091	0.9804	0.8065	0.7692	0.7353	0.7692	0.7143	0.6173	0.5952
358	2ND OF 2 SOLIDS	2/ 9/14/ 0/3/0	CLEAR	0.8772	0.8929	0.7692	0.7692	0.7353	0.6667	0.6944	0.5882	0.5376
369	1ST OF 2 SOLIDS	2/ 3/12/ 0/3/0	CLEAR	1.6129	1.6129	1.0417	0.8475	0.8475	0.8475	0.8197	0.8063	0.7692
369	2ND OF 2 SOLIDS	2/11/16/ 0/3/0 7.150		0.7937	0.7246	0.6024	0.2924	0.0000	0.0000	0.0000	0.0000	0.0000

818	1ST OF 2 SOLIDS	2/11/14/ 0/5/0	CLEAR	0.8333	0.8772	0.7937	0.7692	0.6944	0.6250	0.5814	0.3425	0.2564
818	2ND OF 2 SOLIDS	2/11/14/ 0/5/0	CLEAR	0.8772	0.8333	0.7692	0.6849	0.6250	0.5682	0.3521	0.2890	0.2049
839	1ST OF 2 SOLIDS	2/11/14/ 0/3/0	CLEAR	0.9091	0.9259	0.7692	0.6757	0.6849	0.6329	0.5155	0.4032	0.3378
839	2ND OF 2 SOLIDS	2/ 5/13/ 0/3/0	9.700	0.6667	0.5102	0.3401	0.3049	0.2193	0.2203	0.0000	0.0000	0.0000
916	1ST OF 2 SOLIDS	2/11/14/ 0/3/0	CLEAR	0.9434	0.9434	0.8475	0.7937	0.8065	0.7463	0.6667	0.6579	0.5882
916	2ND OF 2 SOLIDS	2/ 7/14/ 0/5/0	CLEAR	0.9259	0.8929	0.8197	0.8197	0.7246	0.7576	0.6757	0.6329	0.5155
934	1ST OF 2 SOLIDS	2/11/14/ 0/3/0	CLEAR	0.8621	0.9259	0.8475	0.8475	0.7692	0.6849	0.6098	0.5747	0.5000
934	2ND OF 2 SOLIDS	2/ 9/14/ 0/5/0	CLEAR	0.9259	0.8929	0.8621	0.8065	0.7163	0.6849	0.5376	0.5319	0.5618
956	1ST OF 2 SOLIDS	1/ 0/ 0/21/1/0	CLEAR	0.0000	0.0000	0.0000	0.0000	0.0000	0.0000	0.0000	0.0000	0.0000
956	2ND OF 2 SOLIDS	5/12/13/30/5/3	9.570	0.7813	0.7576	0.5882	0.5495	0.5208	0.4950	0.0000	0.0000	0.0000
963	1ST OF 2 SOLIDS	2/12/13/ 0/5/0	CLEAR	0.0000	0.0000	0.0000	0.0000	0.0000	0.7246	0.6757	0.6410	0.6098
963	2ND OF 2 SOLIDS	5/ 9/13/23/3/3	CLEAR	0.9434	0.9615	0.7143	0.5882	0.5682	0.6757	0.6757	0.6098	0.5682
981	1ST OF 2 SOLIDS	2/ 9/14/ 0/3/0	CLEAR	0.9091	0.8621	0.8197	0.8197	0.7463	0.7576	0.6579	0.6024	0.5102
981	2ND OF 2 SOLIDS	2/12/14/ 0/3/0	CLEAR	0.8929	0.8475	0.8333	0.8065	0.7463	0.7042	0.6329	0.5682	0.5155
1035	1ST OF 2 SOLIDS	2/ 7/14/ 0/3/0	CLEAR	1.0000	0.9091	0.7937	0.7813	0.8333	0.7692	0.7163	0.7143	0.6667
1035	2ND OF 2 SOLIDS	2/ 5/14/ 0/3/0	CLEAR	0.8929	0.9259	0.8475	0.7353	0.7463	0.7576	0.6944	0.6494	0.6329
1045	1ST OF 2 SOLIDS	2/ 9/13/ 0/5/0	CLEAR	1.1564	1.1111	1.1111	1.0417	1.0870	1.0638	1.0870	1.0204	0.9434
1045	2ND OF 2 SOLIDS	2/ 9/13/ 0/3/0	CLEAR	1.3514	1.1628	1.1628	1.1364	1.0638	1.1111	1.0870	1.0417	0.9804
1057	1ST OF 2 SOLIDS	6/ 0/ 0/ 0/0/0	CLEAR	0.0000	0.0000	0.0000	0.0000	0.0000	0.0000	0.0000	0.0000	0.5556
1057	2ND OF 2 SOLIDS	2/ 9/16/ 0/5/0	CLEAR	0.8929	0.8333	0.7163	0.7576	0.6757	0.6024	0.5435	0.3378	0.1832
96	1ST OF 3 SOLIDS	3/18/ 0/32/3/0	CLEAR	1.4706	0.8772	0.7143	0.8197	0.6694	0.5319	0.6250	0.5814	0.5814
96	2ND OF 3 SOLIDS	2/ 7/13/ 0/3/0	CLEAR	0.8475	0.8475	0.5051	0.4630	0.5051	0.4274	0.4032	0.3676	0.3937
96	3RD OF 3 SOLIDS	6/ 4/13/ 0/5/0	10.710	0.7937	0.8772	0.5000	0.4132	0.6000	0.3012	0.3067	0.0000	0.0000
229	1ST OF 3 SOLIDS	3/19/ 0/32/4/0	CLEAR	0.0000	0.0000	0.0000	0.0000	0.6024	0.5495	0.5208	0.4202	0.3401
229	2ND OF 3 SOLIDS	2/ 4/13/ 0/3/0	CLEAR	0.8197	0.5882	0.4098	0.5000	0.5051	0.4425	0.4132	0.3012	0.2876
229	3RD OF 3 SOLIDS	2/ 5/13/ 0/3/0	CLEAR	0.8772	0.7143	0.3968	0.3817	0.4065	0.3876	0.3623	0.2941	0.2762
279	1ST OF 3 SOLIDS	2/ 6/14/ 0/3/0	CLEAR	1.1628	1.1905	0.8929	0.8475	0.9259	0.9804	0.9615	0.8197	0.7042
279	2ND OF 3 SOLIDS	2/ 6/14/ 0/3/0	CLEAR	1.0638	1.0000	1.0000	0.9615	0.9434	0.8621	0.8475	0.7813	0.6667
279	3RD OF 3 SOLIDS	2/11/14/ 0/3/0	CLEAR	1.0870	1.1111	0.8475	0.7692	0.7163	0.5495	0.3425	0.0867	0.0909
321	1ST OF 3 SOLIDS	1/ 4/ 3/ 1/0/0	CLEAR	1.0000	1.1111	0.8621	0.8197	0.8675	0.7813	0.8197	0.7463	0.6494
321	2ND OF 3 SOLIDS	1/ 5/ 6/ 1/0/0	CLEAR	0.9804	1.0870	0.8333	0.8333	0.8621	0.7692	0.8475	0.6757	0.6494
321	3RD OF 3 SOLIDS	2/ 9/14/ 0/3/0	CLEAR	0.8772	0.9259	0.7692	0.6944	0.6667	0.6757	0.6379	0.5376	0.4630
329	1ST OF 3 SOLIDS	1/ 5/ 4/ 2/0/0	CLEAR	0.9091	1.0000	0.8065	0.7813	0.7246	0.6849	0.7143	0.6757	0.6250
329	2ND OF 3 SOLIDS	1/ 5/ 4/ 1/0/0	CLEAR	0.8621	0.9259	0.7576	0.6329	0.6667	0.6944	0.6379	0.4808	0.3571
329	3RD OF 3 SOLIDS	2/ 7/14/ 0/3/0	CLEAR	0.7463	0.8772	0.6494	0.5051	0.3846	0.2092	0.1618	0.1412	0.0883
552	1ST OF 3 SOLIDS	2/11/14/ 0/3/0	CLEAR	0.8929	0.8333	0.7937	0.6667	0.7692	0.7143	0.7353	0.7576	0.7143
552	2ND OF 3 SOLIDS	2/11/14/ 0/3/0	CLEAR	0.9259	0.8197	0.8065	0.7246	0.7042	0.6849	0.5952	0.5000	0.6098
552	3RD OF 3 SOLIDS	2/11/14/ 0/3/0	CLEAR	0.8621	0.8675	0.7813	0.7062	0.6379	0.6250	0.5356	0.3876	0.4065
564	1ST OF 3 SOLIDS	2/ 9/15/ 0/5/0	CLEAR	0.0000	0.0000	0.0000	0.0000	0.0000	0.7042	0.7353	0.6849	0.6379
564	2ND OF 3 SOLIDS	2/ 9/14/ 0/3/0	CLEAR	0.9804	0.9615	0.8475	0.6494	0.6250	0.7246	0.7062	0.6849	0.6250
564	3RD OF 3 SOLIDS	2/ 9/14/ 0/3/0	CLEAR	1.0000	0.9259	0.8065	0.7163	0.6494	0.7246	0.7246	0.6944	0.6024
622	1ST OF 3 SOLIDS	2/ 7/14/ 0/3/0	CLEAR	1.0417	0.9615	0.9259	0.8621	0.8621	0.8333	0.8065	0.7576	0.7246
622	2ND OF 3 SOLIDS	3/18/ 0/33/3/0	CLEAR	0.9259	0.9615	0.9091	0.8197	0.7813	0.7937	0.7692	0.6944	0.6410
622	3RD OF 3 SOLIDS	2/ 3/14/ 0/3/0	CLEAR	0.6667	0.5556	0.3267	0.2809	0.2525	0.2959	0.3030	0.2538	0.1852
630	1ST OF 3 SOLIDS	2/ 4/14/ 0/3/0	CLEAR	0.9615	1.0204	0.9434	0.8929	0.8065	0.7463	0.7463	0.7576	0.7692
630	2ND OF 3 SOLIDS	2/ 9/14/ 0/3/0	CLEAR	1.0204	0.9259	0.8621	0.7463	0.7576	0.7576	0.7813	0.6757	0.6329
630	3RD OF 3 SOLIDS	2/11/14/ 0/3/0	CLEAR	1.0000	0.9091	0.7813	0.7463	0.7353	0.7692	0.6944	0.6494	0.5882

642	1ST OF 3 SOLIDS	1/ 4/ 6/ 1/2/0	CLEAR	0.8621	1.0204	0.8475	0.8333	0.7813	0.6379	0.6667	0.6579	0.5376
642	2ND OF 3 SOLIDS	1/ 4/ 6/ 1/2/0	CLEAR	0.7576	0.8772	0.8621	0.7353	0.6494	0.7143	0.5932	0.4673	0.6032
642	3RD OF 3 SOLIDS	2/ 7/14/ 0/3/0	CLEAR	0.8929	0.8475	0.7692	0.7353	0.6944	0.6329	0.5932	0.4950	0.4587
671	1ST OF 3 SOLIDS	2/ 7/14/ 0/3/0	CLEAR	1.0870	1.0870	0.6410	0.8065	0.6250	0.8929	0.8621	0.7692	0.7576
671	2ND OF 3 SOLIDS	1/ 0/ 0/ 3/1/0	CLEAR	0.9091	0.9259	0.7937	0.6694	0.6329	0.5932	0.5155	0.4032	0.4348
671	3RD OF 3 SOLIDS	5/ 7/14/ 1/5/3	11.448	0.8929	0.8197	0.6737	0.5952	0.4386	0.2941	0.2193	0.1182	0.0000
685	1ST OF 3 SOLIDS	1/ 7/ 8/ 1/2/0	CLEAR	0.0000	0.0000	0.0000	0.0000	0.0000	0.6329	0.5208	0.3571	0.2193
685	2ND OF 3 SOLIDS	2/11/16/ 0/5/0	CLEAR	0.0000	0.0000	0.0000	0.0000	0.4630	0.6250	0.5319	0.3788	0.1597
685	3RD OF 3 SOLIDS	2/ 9/14/ 0/5/0	CLEAR	0.8621	0.7576	0.5455	0.4098	0.3571	0.3731	0.2841	0.1786	0.2262
699	1ST OF 3 SOLIDS	1/ 3/ 5/ 1/1/0	CLEAR	1.1564	1.1111	0.7692	0.9434	0.9091	0.9091	0.9259	0.9259	0.7692
699	2ND OF 3 SOLIDS	2/ 7/14/ 0/3/0	CLEAR	0.9804	0.9434	0.8929	0.8475	0.8197	0.8065	0.7937	0.7246	0.7042
699	3RD OF 3 SOLIDS	2/ 7/14/ 0/3/0	CLEAR	0.8065	0.8772	0.7143	0.6579	0.5682	0.5208	0.4464	0.3788	0.3371
727	1ST OF 3 SOLIDS	2/10/14/ 0/3/0	CLEAR	0.8929	0.9091	0.9615	0.8475	0.6944	0.7353	0.6849	0.6329	0.5435
727	2ND OF 3 SOLIDS	2/ 7/14/ 0/3/0	CLEAR	0.9091	0.9615	0.8065	0.7353	0.6944	0.7042	0.6250	0.5376	0.4673
727	3RD OF 3 SOLIDS	2/ 7/14/ 0/3/0	CLEAR	0.9434	0.9615	0.7813	0.7246	0.6849	0.6579	0.5882	0.5051	0.3788
748	1ST OF 3 SOLIDS	1/ 6/ 5/ 1/1/0	CLEAR	1.2195	1.1905	1.0417	1.0204	0.7246	0.8772	0.7353	0.7576	0.7813
748	2ND OF 3 SOLIDS	1/ 0/ 0/ 5/1/0	CLEAR	0.0000	0.0000	0.0000	0.0000	0.0000	0.0000	0.0000	0.0000	0.0000
748	3RD OF 3 SOLIDS	2/ 9/14/ 0/3/0	CLEAR	0.9434	0.9259	0.8197	0.8197	0.7937	0.7692	0.7353	0.6494	0.6250
940	1ST OF 3 SOLIDS	1/ 0/ 0/24/1/0	CLEAR	0.8333	0.7937	0.8772	1.1364	0.7246	0.7042	0.7246	0.7463	0.6329
940	2ND OF 3 SOLIDS	2/ 9/14/ 0/3/0	CLEAR	0.9434	0.8065	0.7813	0.7692	0.7042	0.6379	0.5932	0.5495	0.4673
940	3RD OF 3 SOLIDS	2/ 9/14/ 0/3/0	CLEAR	0.8333	0.8065	0.7692	0.7143	0.6849	0.6849	0.6757	0.4950	0.4762
987	1ST OF 3 SOLIDS	2/ 7/14/ 0/3/0	CLEAR	1.0638	0.9434	0.8065	0.9091	0.8333	0.8675	0.7062	0.6849	0.7353
987	2ND OF 3 SOLIDS	2/ 7/14/ 0/3/0	CLEAR	0.9615	0.8929	0.8929	0.8333	0.8475	0.7376	0.7266	0.7143	0.6757
987	3RD OF 3 SOLIDS	2/ 7/14/ 0/3/0	CLEAR	0.9434	0.9804	0.8621	0.8772	0.7813	0.7937	0.7463	0.7246	0.6849
497	1ST OF 4 SOLIDS	1/ 7/ 4/ 1/1/0	CLEAR	1.0638	1.0417	0.9434	0.8929	0.7813	0.9259	0.8065	0.7813	0.7143
497	2ND OF 4 SOLIDS	1/ 5/ 4/ 1/1/0	CLEAR	1.1111	0.8621	0.9615	0.8333	0.7813	0.8929	0.8065	0.7143	0.6667
497	3RD OF 4 SOLIDS	1/ 5/ 4/ 1/1/0	CLEAR	0.8621	1.0000	0.8772	0.8065	0.8475	0.8333	0.8675	0.6757	0.6667
497	4TH OF 4 SOLIDS	2/11/14/ 0/3/0	CLEAR	0.8333	0.8475	0.7353	0.6944	0.5747	0.5000	0.2668	0.2564	0.2273
628	1ST OF 4 SOLIDS	2/ 7/14/ 0/5/0	CLEAR	0.9091	1.1628	1.0204	0.7937	0.8197	0.7663	0.6329	0.3049	0.1538
628	2ND OF 4 SOLIDS	2/ 7/14/ 0/5/0	CLEAR	1.2821	1.0870	0.7937	0.7813	0.6849	0.4274	0.3876	0.1295	0.0727
628	3RD OF 4 SOLIDS	2/ 7/14/ 0/5/0	11.510	1.2195	0.8621	0.8197	0.6944	0.4902	0.3937	0.1993	0.0797	0.0000
628	4TH OF 4 SOLIDS	2/ 7/14/ 0/5/0	10.500	1.1111	0.9804	0.8065	0.6579	0.5263	0.3846	0.1529	0.0000	0.0000
676	1ST OF 4 SOLIDS	1/ 0/ 0/ 4/1/0	CLEAR	0.0000	0.0000	0.0000	0.0000	0.0000	0.0000	0.0000	0.0000	0.0000
676	2ND OF 4 SOLIDS	1/ 3/ 5/ 1/2/0	CLEAR	0.8772	0.8333	0.7813	0.7246	0.6849	0.6024	0.5495	0.3788	0.2475
676	3RD OF 4 SOLIDS	5/11/14/ 1/3/2	CLEAR	0.9091	0.8929	0.8197	0.7576	0.6944	0.6494	0.5376	0.3676	0.2262
676	4TH OF 4 SOLIDS	2/ 9/14/ 0/5/0	7.040	0.7143	0.6579	0.3106	0.0000	0.0000	0.0000	0.0000	0.0000	0.0000
684	1ST OF 4 SOLIDS	1/ 3/ 4/ 1/2/0	CLEAR	0.9091	0.8197	0.7246	0.6849	0.3817	0.3425	0.2273	0.2513	0.1938
684	2ND OF 4 SOLIDS	1/ 0/ 0/ 5/1/0	CLEAR	0.0000	0.0000	0.0000	0.0000	0.0000	0.0000	0.0000	0.0000	0.0000
684	3RD OF 4 SOLIDS	1/ 7/ 8/ 1/2/0	8.070	0.8333	0.7376	0.6849	0.4902	0.0000	0.0000	0.0000	0.0000	0.0000
684	4TH OF 4 SOLIDS	2/11/16/ 0/5/0	8.070	0.5882	0.3759	0.1730	0.0000	0.0000	0.0000	0.0000	0.0000	0.0000
701	1ST OF 4 SOLIDS	1/ 5/ 6/ 1/1/0	CLEAR	1.1111	0.9259	0.8929	0.8621	0.6757	0.8772	0.7353	0.7143	0.5747
701	2ND OF 4 SOLIDS	1/ 4/ 6/ 1/1/0	CLEAR	0.9434	0.9091	0.9091	0.7813	0.7463	0.8475	0.6944	0.5682	0.5618
701	3RD OF 4 SOLIDS	2/11/14/ 0/3/0	CLEAR	0.7813	0.8333	0.7463	0.6667	0.5932	0.5102	0.3468	0.2232	0.1623
701	4TH OF 4 SOLIDS	2/11/15/ 0/3/0	CLEAR	0.8333	0.7937	0.7463	0.6329	0.6024	0.4717	0.3125	0.2137	0.1634
907	1ST OF 4 SOLIDS	1/ 4/ 6/ 1/2/0	CLEAR	0.9091	0.9804	0.8065	0.8065	0.6379	0.7246	0.6849	0.8197	0.6173
907	2ND OF 4 SOLIDS	2/11/15/ 0/3/0	CLEAR	0.9091	0.9804	0.8065	0.8065	0.6379	0.7246	0.6849	0.8197	0.6173
907	3RD OF 4 SOLIDS	1/ 5/ 6/ 1/2/0	CLEAR	0.9091	0.9804	0.8065	0.8065	0.6379	0.7246	0.6849	0.8197	0.6173
907	4TH OF 4 SOLIDS	2/ 5/14/ 0/3/0	CLEAR	0.8065	0.7143	0.5747	0.4348	0.3268	0.2907	0.2841	0.2841	0.2364
961	1ST OF 4 SOLIDS	1/ 2/ 4/ 1/2/0	CLEAR	1.6129	1.1628	1.0417	0.9091	0.6173	1.1628	0.8065	0.7937	0.7463
961	2ND OF 4 SOLIDS	1/ 2/ 4/ 1/2/0	CLEAR	1.0870	1.0417	0.8333	1.3516	0.6329	1.2195	0.6737	0.7937	0.6379
961	3RD OF 4 SOLIDS	1/ 5/ 8/ 1/2/0	CLEAR	0.9615	0.8772	0.8621	0.7576	0.6849	0.6098	0.6410	0.5000	0.2762

A3 - 3 Comp. Check No. 2500, Female Main-Line Installation (W.C.3),
Gradient 1:200.

GREENWICH DISTRICT HOSPITAL, ON SITE
MONITORING OF ABOVE GROUND DRAINAGE.
DR. J. A. SWAFFIELD AND MR. S. D. BUKOR,
DRAINAGE RESEARCH GROUP, DEPARTMENT OF
BUILDING TECHNOLOGY BRUNEL UNIVERSITY.

RED W.C. GRADIENT = 1:200.
FEMALE SUITE 6F W.C. S.

NUMBER OF RUNS UNDER COMPARISON = 536.

VELOCITY MEASURING POINT. 1 2 3 4 5 6 7 8 9
DISTANCE (M) FROM W.C. 3.130 4.130 5.130 6.130 7.130 8.130 9.130 10.130 11.130
SENSOR SEPARATION (M) 1.0 1.0 1.0 1.0 1.0 1.0 1.0 1.0 1.0

RUN NO.	RELATIVE PUSH, SOLID IN FLUSH,	CLASSIFICATION STOP NO. OF SOLID,	POSN.	VELOCITY, M/S.								
5	NO OTHER SOLID	2/ 5/14/ 0/3/0	CLEAR	1.0417	0.9091	0.9091	0.7813	0.8065	0.7143	0.7042	0.6494	0.5882
7	NO OTHER SOLID	2/10/15/ 0/3/0	CLEAR	0.9804	0.9091	0.7937	0.6944	0.6098	0.5882	0.4274	0.2994	0.1538
10	NO OTHER SOLID	2/ 7/14/ 0/3/0	CLEAR	1.0000	1.0000	0.8772	0.7813	0.7042	0.7042	0.7042	0.5952	0.6098
11	NO OTHER SOLID	2/11/14/ 0/3/0	CLEAR	1.0204	1.0000	0.8065	0.7576	0.7143	0.7463	0.7143	0.6849	0.6098
12	NO OTHER SOLID	2/12/14/ 0/3/0	CLEAR	1.1111	0.9091	0.8929	0.7813	0.8333	0.7463	0.7042	0.6849	0.5814
15	NO OTHER SOLID	2/11/15/ 0/3/0	CLEAR	1.0204	0.9091	0.7692	0.7692	0.7813	0.7143	0.5952	0.5814	0.4237
16	NO OTHER SOLID	2/ 7/15/ 0/3/0	CLEAR	1.0638	0.9091	0.8333	0.7692	0.7813	0.7042	0.6098	0.6173	0.4808
18	NO OTHER SOLID	2/ 7/15/ 0/3/0	CLEAR	1.0000	0.9091	0.8475	0.7576	0.7143	0.7246	0.5882	0.6024	0.5155
20	NO OTHER SOLID	2/ 7/14/ 0/3/0	CLEAR	1.0638	0.9804	0.8475	0.7937	0.7937	0.7463	0.7042	0.6410	0.5556
23	NO OTHER SOLID	2/ 5/14/ 0/3/0	CLEAR	1.0204	1.0000	0.8475	0.7813	0.7813	0.7576	0.7576	0.6944	0.6410
28	NO OTHER SOLID	2/ 7/14/ 0/3/0	CLEAR	1.0638	0.9434	0.8772	0.7143	0.7813	0.7813	0.7143	0.6579	0.5495
34	NO OTHER SOLID	2/ 5/15/ 0/3/0	CLEAR	1.0000	0.9091	0.8065	0.8197	0.8197	0.7143	0.7143	0.6757	0.6329
37	NO OTHER SOLID	2/ 9/14/ 0/3/0	CLEAR	1.1111	1.0000	0.8621	0.8197	0.7813	0.7463	0.7143	0.6944	0.5952
40	NO OTHER SOLID	2/16/12/ 0/3/0	CLEAR	0.9434	0.9804	0.8197	0.7576	0.7692	0.7576	0.7143	0.7042	0.6410
43	NO OTHER SOLID	2/ 7/15/ 0/3/0	CLEAR	1.0638	1.0000	0.8621	0.7576	0.7353	0.7042	0.7042	0.6494	0.5882
45	NO OTHER SOLID	2/10/15/ 0/3/0	CLEAR	0.9434	0.8772	0.7143	0.6757	0.6869	0.6329	0.5000	0.4717	0.3356
47	NO OTHER SOLID	2/ 5/15/ 0/3/0	CLEAR	1.0204	0.9615	0.8197	0.7576	0.7692	0.7246	0.6494	0.5767	0.5319
48	NO OTHER SOLID	2/ 5/14/ 0/3/0	CLEAR	1.0204	1.0000	0.7937	0.7937	0.8929	0.8621	0.7692	0.6667	0.6173
52	NO OTHER SOLID	2/10/16/ 0/3/0	CLEAR	1.0000	0.9259	0.7813	0.6757	0.6757	0.5556	0.4467	0.2513	0.1563
54	NO OTHER SOLID	2/ 9/14/ 0/3/0	CLEAR	1.0870	0.8475	0.8475	0.8621	0.8675	0.8065	0.7937	0.7692	0.7246
56	NO OTHER SOLID	2/ 5/14/ 0/3/0	CLEAR	1.0870	1.0000	0.8333	0.7813	0.7813	0.7246	0.6667	0.6024	0.5376

57	NO OTHER SOLID	2/ 7/14/ 0/3/0	CLEAR	1.1111	0.9615	0.8621	0.7463	0.7042	0.7692	0.7042	0.6173	0.5319
59	NO OTHER SOLID	2/ 5/15/ 0/3/0	CLEAR	1.0204	1.0000	0.8333	0.7692	0.8197	0.7937	0.7576	0.6667	0.5747
67	NO OTHER SOLID	2/10/15/ 0/3/0	CLEAR	1.0417	0.9434	0.7692	0.7576	0.7692	0.7576	0.6944	0.6098	0.5495
69	NO OTHER SOLID	2/ 5/14/ 0/3/0	CLEAR	1.0204	1.0417	0.9259	0.8197	0.8197	0.7246	0.7042	0.7143	0.6250
78	NO OTHER SOLID	2/15/14/ 0/3/0	CLEAR	1.0417	0.9434	0.8475	0.8333	0.8621	0.7937	0.7463	0.7246	0.6250
86	NO OTHER SOLID	2/12/15/ 0/3/0	CLEAR	0.8772	0.9615	0.8475	0.7353	0.7576	0.7576	0.7042	0.6494	0.5747
89	NO OTHER SOLID	2/ 9/15/ 0/3/0	CLEAR	0.9434	0.9804	0.7813	0.7246	0.7463	0.6944	0.6667	0.5682	0.4808
97	NO OTHER SOLID	2/ 7/14/ 0/3/0	CLEAR	1.1111	1.0000	0.9091	0.7246	0.7576	0.7692	0.6667	0.6173	0.5208
99	NO OTHER SOLID	2/11/14/ 0/3/0	CLEAR	1.0204	1.0000	0.9091	0.8333	0.8475	0.8065	0.7353	0.6849	0.6250
103	NO OTHER SOLID	2/ 7/14/ 0/3/0	CLEAR	1.0417	1.0417	0.9091	0.8333	0.8333	0.7813	0.7813	0.7692	0.7042
113	NO OTHER SOLID	2/13/14/ 0/3/0	CLEAR	1.0000	1.1364	0.8929	0.8621	0.8772	0.8197	0.7463	0.7353	0.6757
114	NO OTHER SOLID	2/ 7/15/ 0/3/0	CLEAR	1.0417	0.9434	0.7937	0.7692	0.7463	0.7246	0.6849	0.6579	0.5155
115	NO OTHER SOLID	2/ 7/14/ 0/3/0	CLEAR	1.0204	0.9804	0.9434	0.8621	0.7813	0.7042	0.7463	0.7246	0.6410
119	NO OTHER SOLID	3/17/ 0/35/0/0	CLEAR	1.1628	0.9434	0.6621	0.7576	0.8065	0.7143	0.7042	0.6667	0.6098
121	NO OTHER SOLID	2/10/15/ 0/3/0	10.330	1.0870	0.9259	0.8772	0.6757	0.6579	0.5051	0.2703	0.0000	0.0000
126	NO OTHER SOLID	2/ 7/16/ 0/3/0	CLEAR	1.1111	0.9804	0.8929	0.7937	0.7576	0.7576	0.7692	0.7143	0.6667
136	NO OTHER SOLID	2/15/15/ 0/3/0	CLEAR	1.0870	0.9804	0.8197	0.7246	0.7463	0.7246	0.6667	0.5814	0.4950
140	NO OTHER SOLID	2/ 7/14/ 0/3/0	CLEAR	1.1111	0.9259	0.8772	0.8065	0.7692	0.7143	0.7353	0.6944	0.6250
141	NO OTHER SOLID	2/ 7/14/ 0/3/0	CLEAR	1.0870	0.9259	0.8333	0.7576	0.7353	0.7353	0.6667	0.6494	0.5952
145	NO OTHER SOLID	2/ 9/14/ 0/3/0	CLEAR	1.0204	1.0204	0.8621	0.8475	0.8475	0.8065	0.7692	0.7353	0.5882
151	NO OTHER SOLID	2/11/14/ 0/3/0	CLEAR	1.0204	0.9804	0.8772	0.7937	0.8065	0.7143	0.6757	0.6250	0.5495
161	NO OTHER SOLID	2/11/14/ 0/3/0	CLEAR	1.1564	1.0638	0.9091	0.8065	0.8333	0.7813	0.7353	0.6944	0.6098
162	NO OTHER SOLID	2/ 7/14/ 0/3/0	CLEAR	1.0417	1.1111	0.8621	0.8065	0.7813	0.7463	0.7576	0.6944	0.6173
165	NO OTHER SOLID	2/ 7/14/30/3/5	8.230	0.9259	0.9259	0.8772	0.6329	0.5263	0.0000	0.0000	0.0000	0.0000
170	NO OTHER SOLID	2/ 9/14/ 0/3/0	CLEAR	1.0417	1.0417	0.8621	0.8333	0.7692	0.7576	0.6944	0.6667	0.6494
184	NO OTHER SOLID	2/ 7/14/ 0/3/0	CLEAR	1.0417	1.0000	0.8065	0.6849	0.7246	0.6944	0.6173	0.5618	0.4464
192	NO OTHER SOLID	2/ 7/15/ 0/3/0	CLEAR	1.0870	1.0204	0.8029	0.8772	0.8475	0.8475	0.7353	0.7143	0.6944
205	NO OTHER SOLID	2/ 9/15/ 0/3/0	CLEAR	1.0638	1.0204	0.9259	0.8197	0.8197	0.7937	0.7353	0.7143	0.6494
206	NO OTHER SOLID	2/ 5/16/ 0/3/0	CLEAR	1.0204	1.0204	0.8475	0.8475	0.8197	0.7576	0.6667	0.6667	0.6098
209	NO OTHER SOLID	2/ 9/15/ 0/3/0	CLEAR	1.0417	1.0870	0.9259	0.8197	0.9091	0.9091	0.7937	0.7692	0.7246
211	NO OTHER SOLID	2/ 5/15/ 0/3/0	CLEAR	1.0870	1.0638	0.8929	0.8675	0.8333	0.8065	0.7246	0.6849	0.6757
213	NO OTHER SOLID	2/11/14/ 0/3/0	CLEAR	1.0638	0.9804	0.9091	0.8197	0.8197	0.7463	0.7576	0.6849	0.6410
223	NO OTHER SOLID	2/11/14/ 0/3/0	CLEAR	1.1111	1.0000	0.8929	0.8333	0.8197	0.8197	0.7937	0.6849	0.6667

224	NO OTHER SOLID	2/ 7/14/ 0/3/0	CLEAR	1.0204	0.8772	0.8333	0.7692	0.7163	0.6024	0.5435	0.4854	0.3876
234	NO OTHER SOLID	2/ 7/15/ 0/3/0	CLEAR	1.0204	1.0204	0.8475	0.7813	0.7813	0.7246	0.7463	0.6579	0.6329
238	NO OTHER SOLID	2/13/12/ 0/3/0	CLEAR	1.3158	0.9615	0.9091	0.8333	0.8197	0.8333	0.7576	0.7463	0.6757
248	NO OTHER SOLID	2/16/15/ 0/3/0	CLEAR	1.1905	1.1364	0.8929	0.8621	0.8621	0.8065	0.7813	0.7937	0.6944
252	NO OTHER SOLID	2/ 5/15/ 0/3/0	CLEAR	1.0204	0.9434	0.9091	0.8065	0.8675	0.7692	0.7692	0.6849	0.6757
254	NO OTHER SOLID	2/13/14/ 0/3/0	CLEAR	1.0000	0.9434	0.8475	0.8197	0.7813	0.7692	0.7246	0.7246	0.6098
256	NO OTHER SOLID	2/ 5/14/ 0/3/0	CLEAR	1.0417	0.9615	0.7937	0.7692	0.7042	0.6667	0.6410	0.5814	0.4902
258	NO OTHER SOLID	2/11/15/ 0/3/0	CLEAR	1.0000	0.9434	0.8197	0.7692	0.7143	0.5882	0.5952	0.5682	0.4854
259	NO OTHER SOLID	2/ 7/14/ 0/3/0	CLEAR	1.0638	0.9615	1.0204	0.9091	0.8772	0.8475	0.8065	0.7937	0.7143
260	NO OTHER SOLID	2/12/14/ 0/3/0	CLEAR	1.0870	0.9804	0.8621	0.7353	0.7353	0.6944	0.6667	0.5747	0.4673
268	NO OTHER SOLID	2/15/15/ 0/3/0	CLEAR	1.1364	0.9804	0.8772	0.8065	0.7937	0.7353	0.7463	0.7042	0.6494
273	NO OTHER SOLID	2/ 7/14/ 0/3/0	CLEAR	1.0870	1.0000	0.8333	0.7463	0.7692	0.7692	0.7143	0.6757	0.5747
286	NO OTHER SOLID	2/13/14/ 0/3/0	CLEAR	1.0417	0.8621	0.7692	0.7463	0.7692	0.7353	0.7143	0.6667	0.5814
290	NO OTHER SOLID	2/16/14/ 0/3/0	CLEAR	1.2195	1.0870	0.8772	0.7143	0.7576	0.7353	0.7143	0.6849	0.6410
295	NO OTHER SOLID	2/ 7/15/ 0/3/0	CLEAR	1.0638	1.0870	0.8772	0.7463	0.7813	0.7463	0.7353	0.7042	0.6173
296	NO OTHER SOLID	2/12/14/ 0/3/0	CLEAR	0.9804	0.9259	0.8621	0.7463	0.7576	0.7692	0.7692	0.7143	0.6098
297	NO OTHER SOLID	2/ 9/16/ 0/3/0	CLEAR	0.9804	1.0204	0.9434	0.8621	0.8772	0.8197	0.7937	0.7813	0.7143
306	NO OTHER SOLID	2/ 5/16/ 0/3/0	CLEAR	1.0417	0.9091	0.8333	0.7463	0.7576	0.6944	0.6173	0.5155	0.3731
310	NO OTHER SOLID	2/11/16/ 0/3/0	CLEAR	1.0000	0.9804	0.8065	0.7813	0.7143	0.7143	0.6250	0.5618	0.4630
311	NO OTHER SOLID	2/ 7/15/ 0/3/0	CLEAR	1.0417	1.0638	0.8929	0.7813	0.7937	0.8065	0.7576	0.7353	0.5747
315	NO OTHER SOLID	2/11/16/ 0/3/0	CLEAR	0.9804	0.9615	0.8675	0.7813	0.8065	0.7937	0.7692	0.6849	0.5952
319	NO OTHER SOLID	2/ 9/16/ 0/3/0	CLEAR	1.1364	1.1364	0.9259	0.8621	0.8621	0.8929	0.7576	0.7246	0.6667
328	NO OTHER SOLID	2/ 7/16/ 0/3/0	CLEAR	0.9615	1.0204	0.8929	0.8621	0.8197	0.7692	0.6757	0.7246	0.6579
335	NO OTHER SOLID	2/15/12/ 0/3/0	CLEAR	1.0870	1.0000	0.8929	0.8333	0.8772	0.8065	0.7353	0.6944	0.6494
339	NO OTHER SOLID	2/ 7/16/ 0/3/0	CLEAR	1.0638	1.0870	0.8197	0.8621	0.8929	0.7937	0.7463	0.6849	0.6098
346	NO OTHER SOLID	2/ 5/14/ 0/3/0	CLEAR	1.0204	1.1111	0.9091	0.9091	0.9259	0.8475	0.8065	0.7246	0.6849
351	NO OTHER SOLID	2/ 4/16/ 0/3/0	CLEAR	1.0417	1.0638	0.9259	0.9091	0.9091	0.8333	0.8333	0.7692	0.7042
355	NO OTHER SOLID	2/11/14/ 0/3/0	CLEAR	1.0204	0.9804	0.8197	0.7576	0.7576	0.7246	0.6944	0.6579	0.5814
356	NO OTHER SOLID	2/ 9/14/ 0/3/0	CLEAR	0.9804	0.9434	0.9259	0.8333	0.7813	0.7576	0.7813	0.7246	0.6667
361	NO OTHER SOLID	2/ 7/15/ 0/3/0	CLEAR	0.9615	1.0638	0.9259	0.7937	0.8065	0.7576	0.7576	0.7692	0.6849
364	NO OTHER SOLID	2/ 7/15/ 0/3/0	CLEAR	1.0000	1.0204	0.8621	0.7143	0.7463	0.6849	0.7463	0.6250	0.5556
368	NO OTHER SOLID	2/16/14/ 0/3/0	CLEAR	1.0870	1.0000	0.8621	0.7937	0.8197	0.7576	0.7463	0.6667	0.6173
370	NO OTHER SOLID	2/11/15/ 0/3/0	CLEAR	1.0000	1.0638	0.8065	0.7246	0.7937	0.7463	0.6944	0.6329	0.5618

379	NO OTHER SOLID	2/15/13/ U/3/0	CLEAR	1.0638	1.0204	0.8475	0.8475	0.7813	0.7353	0.7143	0.7042	0.5682
381	NO OTHER SOLID	2/ 7/16/ U/3/0	CLEAR	1.0000	1.1111	1.0000	0.8929	0.8929	0.8772	0.8197	0.7246	0.7143
384	NO OTHER SOLID	2/12/13/ U/3/0	CLEAR	1.0204	1.0000	0.9259	0.8333	0.8065	0.7463	0.7163	0.7353	0.6667
387	NO OTHER SOLID	2/ 9/14/ U/3/0	CLEAR	1.0417	1.0870	0.8621	0.7813	0.7813	0.7692	0.7813	0.7463	0.6410
388	NO OTHER SOLID	2/12/13/ U/3/0	CLEAR	1.0000	1.0000	0.8772	0.8333	0.7937	0.7576	0.7692	0.6944	0.6410
390	NO OTHER SOLID	2/ 5/16/ U/3/0	CLEAR	1.0870	1.0204	0.8475	0.8065	0.8475	0.7576	0.7692	0.7143	0.6250
401	NO OTHER SOLID	2/11/14/ U/3/0	CLEAR	1.0417	1.0204	0.8621	0.8333	0.7937	0.7576	0.7937	0.6849	0.6250
403	NO OTHER SOLID	2/11/14/ U/3/0	CLEAR	1.0204	1.0417	0.8772	0.8065	0.7143	0.7353	0.7463	0.6410	0.5882
406	NO OTHER SOLID	2/11/14/ U/3/0	CLEAR	0.9804	1.0204	0.9091	0.8197	0.7576	0.6944	0.6757	0.6098	0.5682
408	NO OTHER SOLID	2/11/14/ U/3/0	CLEAR	1.0204	1.0000	0.8065	0.7813	0.7143	0.6944	0.6579	0.5747	0.4902
411	NO OTHER SOLID	2/ 7/14/ U/3/0	CLEAR	0.9091	0.9091	0.7692	0.7463	0.7353	0.6944	0.6579	0.5882	0.5000
414	NO OTHER SOLID	2/ 9/16/ U/3/0	CLEAR	0.9804	1.0204	0.8475	0.7813	0.7576	0.7042	0.7576	0.6579	0.5618
416	NO OTHER SOLID	2/11/14/ U/3/0	CLEAR	0.8929	0.9434	0.9259	0.8621	0.8333	0.7692	0.7813	0.6849	0.5376
417	NO OTHER SOLID	2/ 9/16/ U/3/0	CLEAR	0.9091	0.9615	0.8621	0.7937	0.7246	0.7042	0.6410	0.5814	0.4274
427	NO OTHER SOLID	2/11/16/ U/3/0	CLEAR	1.0204	0.9615	0.9259	0.7576	0.6667	0.6667	0.6944	0.5376	0.3817
430	NO OTHER SOLID	2/11/16/ U/3/0	CLEAR	1.0417	1.0204	0.8621	0.8197	0.8333	0.7813	0.7353	0.6849	0.5747
432	NO OTHER SOLID	2/ 9/14/ U/3/0	CLEAR	0.9091	0.8929	0.6849	0.6579	0.6250	0.5102	0.4673	0.3846	0.2564
436	NO OTHER SOLID	2/ 7/16/ U/3/0	CLEAR	1.0000	0.8929	0.8475	0.7937	0.6849	0.7143	0.6329	0.5495	0.4545
440	NO OTHER SOLID	2/ 5/14/ U/3/0	CLEAR	1.1364	1.1364	0.9259	0.8475	0.8333	0.8621	0.8475	0.7692	0.6944
449	NO OTHER SOLID	2/12/13/ U/3/0	CLEAR	1.0204	1.0417	0.8929	0.7692	0.7692	0.7576	0.7813	0.7042	0.6098
450	NO OTHER SOLID	2/11/14/ U/3/0	CLEAR	1.1111	0.9615	0.9615	0.8197	0.8475	0.7813	0.8333	0.7692	0.7463
452	NO OTHER SOLID	2/11/14/ U/3/0	CLEAR	0.9615	1.0417	0.8333	0.7692	0.7463	0.7246	0.6849	0.6098	0.5814
459	NO OTHER SOLID	2/ 7/16/ U/3/0	CLEAR	1.0000	1.0417	0.8475	0.8333	0.8475	0.8333	0.7692	0.7463	0.6849
464	NO OTHER SOLID	2/ 7/15/ U/3/0	CLEAR	1.1905	1.0870	0.8929	0.8621	0.7937	0.8065	0.7463	0.7576	0.6494
470	NO OTHER SOLID	2/ 7/16/ U/3/0	CLEAR	1.0417	1.0000	0.9091	0.8621	0.7937	0.8065	0.7692	0.7576	0.7246
473	NO OTHER SOLID	6/ 0/ 0/ U/0/0	CLEAR	1.4286	0.9804	0.9259	0.9434	0.8065	0.7692	0.6667	0.6757	0.6757
476	NO OTHER SOLID	2/ 7/15/ U/3/0	CLEAR	1.0638	1.0417	0.8621	0.8333	0.8475	0.8475	0.8333	0.7576	0.7463
493	NO OTHER SOLID	2/ 9/14/ U/3/0	CLEAR	1.0870	1.0638	0.9091	0.8475	0.7937	0.7937	0.7937	0.7143	0.6579
496	NO OTHER SOLID	2/ 4/16/ U/3/0	CLEAR	1.0417	1.0204	0.8621	0.8333	0.7813	0.7937	0.7692	0.6944	0.6098
503	NO OTHER SOLID	2/ 5/16/ U/3/0	CLEAR	1.0870	1.0870	0.8333	0.7692	0.7692	0.7576	0.7692	0.7463	0.6250
515	NO OTHER SOLID	2/ 9/16/ U/3/0	CLEAR	1.0417	0.9804	0.8197	0.7463	0.7042	0.6579	0.6494	0.5495	0.4545
517	NO OTHER SOLID	2/ 9/14/ U/3/0	CLEAR	1.0204	1.0000	0.9615	0.8333	0.8333	0.8065	0.7692	0.7576	0.7042
522	NO OTHER SOLID	2/11/15/ U/3/0	CLEAR	1.0638	0.9615	0.8197	0.7692	0.7576	0.6667	0.6494	0.4854	0.4348

524	NO OTHER SOLID	2/ 5/14/ 0/3/0	CLEAR	1.1111	1.1111	0.9615	0.8197	0.8333	0.8333	0.8333	0.8333	0.7813	0.7576
525	NO OTHER SOLID	2/11/14/ 0/3/0	CLEAR	1.0000	0.9615	0.8475	0.7576	0.8197	0.7576	0.7576	0.7576	0.6410	0.5682
526	NO OTHER SOLID	2/15/14/ 0/3/0	CLEAR	0.8475	0.8929	0.7813	0.6667	0.6494	0.5882	0.5882	0.5000	0.3676	0.2347
535	NO OTHER SOLID	2/ 9/14/ 0/3/0	CLEAR	1.1628	1.0638	0.9434	0.8621	0.8929	0.8065	0.7692	0.7246	0.7246	0.7576
551	NO OTHER SOLID	2/11/14/ 0/3/0	CLEAR	1.0870	1.0417	0.9434	0.8475	0.8772	0.7937	0.7576	0.7246	0.7246	0.7042
553	NO OTHER SOLID	2/ 7/15/ 0/3/0	CLEAR	1.0638	1.0204	0.9615	0.8197	0.8621	0.8197	0.8475	0.7576	0.7576	0.6667
556	NO OTHER SOLID	2/ 9/16/ 0/3/0	CLEAR	0.9615	0.9615	0.8475	0.7813	0.7246	0.7463	0.7042	0.7042	0.6329	0.5495
563	NO OTHER SOLID	2/ 7/15/ 0/3/0	CLEAR	0.8772	0.9091	0.8475	0.8475	0.8772	0.7692	0.7042	0.7042	0.6849	0.6329
575	NO OTHER SOLID	2/ 7/15/ 0/3/0	CLEAR	1.0638	1.0417	0.9259	0.7576	0.7813	0.8065	0.7937	0.6944	0.6944	0.6250
575	NO OTHER SOLID	1/ 4/ 5/ 1/2/0	CLEAR	0.0000	0.0000	0.0000	0.0000	0.0000	0.0000	0.0000	0.0000	0.6098	0.5747
581	NO OTHER SOLID	2/ 9/15/ 0/3/0	6.750	1.0417	0.8929	0.5952	0.3759	0.0000	0.0000	0.0000	0.0000	0.0000	0.0000
588	NO OTHER SOLID	2/ 5/15/ 0/3/0	CLEAR	1.0417	1.0638	0.8333	0.7463	0.8333	0.7246	0.7246	0.7246	0.6410	0.5682
590	NO OTHER SOLID	2/ 9/14/ 0/3/0	CLEAR	0.0000	0.0000	0.0000	0.0000	0.0000	0.0000	0.0000	0.0000	0.0000	0.0000
598	NO OTHER SOLID	2/12/14/ 0/3/0	CLEAR	1.0204	1.0417	0.9259	0.8533	0.7937	0.7353	0.7042	0.6667	0.6667	0.6098
604	NO OTHER SOLID	2/ 7/15/ 0/3/0	CLEAR	0.9804	1.0000	0.8197	0.7937	0.7576	0.7246	0.6944	0.5882	0.5882	0.5263
610	NO OTHER SOLID	2/ 5/14/ 0/3/0	CLEAR	1.0000	1.1111	0.8929	0.8333	0.7813	0.7463	0.7042	0.7143	0.7143	0.6024
611	NO OTHER SOLID	2/ 9/14/ 0/3/0	CLEAR	1.0204	1.0870	0.9259	0.8065	0.8197	0.7246	0.6757	0.5747	0.4902	0.4902
613	NO OTHER SOLID	2/ 7/14/ 0/3/0	CLEAR	1.0870	1.0000	0.8333	0.7576	0.6944	0.5882	0.5556	0.4808	0.4808	0.3817
614	NO OTHER SOLID	2/10/14/ 0/3/0	CLEAR	1.0000	0.9804	0.8621	0.7692	0.7143	0.6579	0.5435	0.4032	0.2732	0.2732
619	NO OTHER SOLID	2/ 7/15/ 0/3/0	CLEAR	1.0417	1.0638	0.8197	0.8333	0.8772	0.7692	0.7576	0.6849	0.6849	0.6250
622	NO OTHER SOLID	2/12/15/ 0/3/0	CLEAR	1.0204	0.9804	0.8333	0.7813	0.7463	0.7246	0.6494	0.6024	0.4808	0.4808
623	NO OTHER SOLID	2/ 9/14/ 0/3/0	CLEAR	1.1111	1.0638	0.9804	0.8772	0.8197	0.7246	0.6944	0.7042	0.6024	0.6024
624	NO OTHER SOLID	2/ 7/15/ 0/3/0	CLEAR	1.0638	1.0204	0.9434	0.8621	0.8333	0.7576	0.7246	0.6944	0.6250	0.6250
629	NO OTHER SOLID	2/ 7/14/ 0/3/0	CLEAR	1.0417	1.0638	0.8772	0.7937	0.7692	0.7042	0.6849	0.6667	0.5376	0.5376
633	NO OTHER SOLID	2/ 7/14/ 0/3/0	CLEAR	1.0000	1.0204	0.8197	0.7576	0.7353	0.6579	0.6494	0.5435	0.4274	0.4274
634	NO OTHER SOLID	2/ 7/15/ 0/3/0	CLEAR	1.0638	0.8929	0.7813	0.7353	0.6410	0.5682	0.5263	0.4425	0.3571	0.3571
635	NO OTHER SOLID	2/ 9/14/ 0/3/0	CLEAR	0.9434	1.0417	0.8772	0.7937	0.7692	0.6849	0.6410	0.5435	0.4368	0.4368
637	NO OTHER SOLID	2/16/12/ 0/3/0	CLEAR	1.0204	1.0638	0.8772	0.8333	0.7813	0.7463	0.7576	0.6494	0.5556	0.5556
639	NO OTHER SOLID	2/ 5/14/ 0/3/0	CLEAR	1.0638	1.0417	0.8621	0.8065	0.8065	0.7353	0.7353	0.6173	0.5102	0.5102
640	NO OTHER SOLID	2/ 4/14/ 0/3/0	CLEAR	0.9091	1.0417	0.8772	0.8065	0.8065	0.7576	0.7143	0.6098	0.5319	0.5319
641	NO OTHER SOLID	2/13/14/ 0/3/0	11.200	1.0638	0.9259	0.6849	0.5263	0.2959	0.1064	0.0799	0.0996	0.0000	0.0000
643	NO OTHER SOLID	2/ 5/15/ 0/3/0	CLEAR	1.0417	1.0000	0.7692	0.6667	0.5682	0.4630	0.4098	0.3468	0.2551	0.2551
646	NO OTHER SOLID	2/ 4/14/ 0/3/0	CLEAR	1.0417	1.0204	0.8929	0.8772	0.8772	0.7937	0.7143	0.6944	0.6494	0.6494

875	NO OTHER SOLID	2/ 7/14/ 0/3/0	CLEAR	1.0000	1.0000	0.8065	0.7143	0.7246	0.6579	0.6173	0.5155	0.4237
876	NO OTHER SOLID	2/ 9/14/ 0/3/0	CLEAR	0.9615	1.0417	0.8475	0.8333	0.7937	0.6667	0.5952	0.4950	0.4052
880	NO OTHER SOLID	2/ 5/14/ 0/3/0	CLEAR	0.9434	0.8333	0.6173	0.4167	0.1852	0.1475	0.1437	0.1712	0.1401
882	NO OTHER SOLID	2/ 9/14/ 0/3/0	CLEAR	1.0417	1.0870	0.8929	0.8197	0.8333	0.7576	0.8065	0.7143	0.6173
884	NO OTHER SOLID	2/ 7/14/ 0/3/0	CLEAR	0.8772	0.9804	0.8197	0.7353	0.6944	0.6250	0.5952	0.4854	0.3788
890	NO OTHER SOLID	2/ 5/13/ 0/3/0	CLEAR	0.0000	0.0000	0.0000	0.0000	0.0000	0.0000	0.0000	0.5682	0.5814
894	NO OTHER SOLID	2/ 5/16/ 0/3/0	CLEAR	0.9615	0.9434	0.7937	0.7937	0.7692	0.6579	0.5682	0.4505	0.3165
897	NO OTHER SOLID	2/ 9/14/ 0/3/0	CLEAR	1.0870	1.0417	0.9259	0.9259	0.8065	0.7937	0.7692	0.7143	0.6173
902	NO OTHER SOLID	2/ 7/14/ 0/3/0	CLEAR	1.0417	1.0638	0.9091	0.8197	0.8065	0.7353	0.7576	0.7042	0.6250
915	NO OTHER SOLID	2/ 7/15/ 0/3/0	CLEAR	1.0638	1.0204	0.8333	0.8333	0.8621	0.7937	0.7143	0.6944	0.5952
916	NO OTHER SOLID	2/ 7/14/ 0/3/0	CLEAR	1.0204	1.0204	0.8621	0.8772	0.8772	0.8333	0.7692	0.7042	0.6098
917	NO OTHER SOLID	2/11/15/ 0/3/0	CLEAR	1.0000	0.8929	0.8197	0.7937	0.7692	0.6173	0.5263	0.4310	0.3333
918	NO OTHER SOLID	2/ 9/15/ 0/3/0	CLEAR	0.9804	0.9434	0.8621	0.7813	0.7463	0.7246	0.6250	0.4950	0.3205
920	NO OTHER SOLID	2/ 5/13/ 0/3/0	9.090	0.9434	0.6197	0.5814	0.3546	0.1344	0.0782	0.0000	0.0000	0.0000
924	NO OTHER SOLID	2/ 5/14/ 0/3/0	CLEAR	0.9091	0.7813	0.5376	0.5676	0.3521	0.2841	0.3049	0.2632	0.2513
925	NO OTHER SOLID	2/ 7/14/ 0/3/0	CLEAR	1.0417	1.0204	0.8621	0.8675	0.8929	0.7937	0.7813	0.6757	0.6173
933	NO OTHER SOLID	2/ 5/14/ 0/3/0	CLEAR	0.0000	0.0000	0.0000	0.0000	0.9259	0.8772	0.8621	0.7813	0.7246
937	NO OTHER SOLID	2/ 7/15/ 0/3/0	CLEAR	0.0000	0.0000	0.0000	0.0000	0.0000	0.0000	0.0000	0.0000	0.7042
957	NO OTHER SOLID	2/ 5/16/ 0/3/0	CLEAR	0.9091	0.9091	0.7353	0.6494	0.6173	0.5435	0.4545	0.3846	0.3106
960	NO OTHER SOLID	2/ 7/16/ 0/3/0	CLEAR	1.0204	0.9434	0.9434	0.8333	0.8065	0.7463	0.6757	0.5814	0.5319
963	NO OTHER SOLID	2/ 9/13/ 0/3/0	CLEAR	0.9091	0.9434	0.5882	0.4505	0.2825	0.1767	0.1825	0.2092	0.1712
966	NO OTHER SOLID	2/ 7/15/ 0/3/0	CLEAR	1.0417	1.0000	0.8929	0.8197	0.7692	0.7813	0.6849	0.5882	0.5051
979	NO OTHER SOLID	2/ 5/15/ 0/3/0	CLEAR	1.0204	1.0870	0.8929	0.8772	0.8929	0.8333	0.8065	0.7353	0.6757
982	NO OTHER SOLID	2/ 7/14/ 0/3/0	CLEAR	1.0000	1.0000	0.7576	0.6849	0.6410	0.5155	0.4545	0.3876	0.2959
991	NO OTHER SOLID	1/ 5/ 6/ 1/1/0	CLEAR	1.0000	0.9615	0.8197	0.7813	0.8621	0.7937	0.7246	0.6173	0.5435
1000	NO OTHER SOLID	2/ 9/15/ 0/3/0	CLEAR	1.0000	1.0204	0.8929	0.8475	0.8065	0.7692	0.6849	0.5556	0.4464
1005	NO OTHER SOLID	2/ 7/14/ 0/3/0	CLEAR	1.0638	1.0204	0.9259	0.8475	0.8065	0.7692	0.8065	0.7143	0.5882
1009	NO OTHER SOLID	2/ 9/15/ 0/3/0	CLEAR	1.0000	1.0417	0.8621	0.7937	0.7813	0.7692	0.7143	0.6098	0.4808
1018	NO OTHER SOLID	2/ 9/14/ 0/3/0	CLEAR	1.0000	1.1111	0.9615	0.8929	0.7692	0.7576	0.7937	0.7246	0.6098
1019	NO OTHER SOLID	2/ 9/14/ 0/3/0	CLEAR	1.0870	1.1111	0.8475	0.7463	0.7576	0.7042	0.6024	0.4587	0.5937
1021	NO OTHER SOLID	2/ 5/16/ 0/3/0	CLEAR	0.8772	0.9259	0.7576	0.7576	0.7576	0.6667	0.6329	0.5952	0.4902
9	1ST OF 2 SOLIDS	2/ 6/13/ 0/3/0	CLEAR	1.0870	0.9804	0.9615	0.8197	0.8929	0.8475	0.7937	0.7353	0.6944
9	2ND OF 2 SOLIDS	2/ 4/13/ 0/3/0	CLEAR	1.0000	0.9615	0.9434	0.7937	0.8197	0.7937	0.7143	0.7143	0.6410

342	1ST OF 2 SOLIDS	2/11/14/	0/5/0	CLEAR	0.0000	0.0000	0.0000	0.0000	0.0000	0.7692	0.8621	0.8929	0.8065	0.7576
342	2ND OF 2 SOLIDS	2/ 8/14/	0/5/0	CLEAR	1.0000	0.8929	0.6579	0.5747	0.7353	0.6494	0.7353	0.7692	0.7042	0.6250
359	1ST OF 2 SOLIDS	2/ 6/14/	0/5/0	CLEAR	1.0870	1.0638	0.9434	0.8333	0.7463	0.8621	0.7463	0.7692	0.7143	0.7692
359	2ND OF 2 SOLIDS	2/ 4/14/	0/5/0	CLEAR	1.0000	1.0000	0.8333	0.8333	0.7353	0.8197	0.7353	0.7576	0.7576	0.7463
371	1ST OF 2 SOLIDS	2/ 7/14/	0/5/0	CLEAR	1.0638	1.1111	0.9259	0.8333	0.8333	0.8621	0.8333	0.8333	0.7813	0.7353
371	2ND OF 2 SOLIDS	2/ 7/14/	0/5/0	CLEAR	1.0870	1.0417	0.8475	0.8772	0.8197	0.8333	0.8197	0.7937	0.7692	0.7576
373	1ST OF 2 SOLIDS	2/11/13/	0/5/0	CLEAR	1.0204	0.9434	1.0417	0.9091	0.7937	0.7937	0.7463	0.7042	0.6757	0.6173
373	2ND OF 2 SOLIDS	2/13/13/	0/5/0	CLEAR	1.0417	0.9615	0.8772	0.7813	0.7692	0.7463	0.7463	0.7042	0.6329	0.5814
394	1ST OF 2 SOLIDS	2/ 7/15/	0/5/0	CLEAR	0.9259	1.0204	0.7937	0.7813	0.7353	0.7353	0.7246	0.7246	0.6494	0.5747
394	2ND OF 2 SOLIDS	2/ 4/12/	0/5/0	CLEAR	0.9804	1.0000	0.7353	0.7246	0.7353	0.7353	0.7143	0.7143	0.6610	0.5682
402	1ST OF 2 SOLIDS	2/16/13/	0/5/0	CLEAR	1.0870	1.1628	0.8772	0.6849	0.7353	0.7353	0.7463	0.7463	0.6410	0.5102
402	2ND OF 2 SOLIDS	2/16/13/	0/5/0	CLEAR	0.9804	0.9434	0.7576	0.7042	0.7042	0.7042	0.6329	0.5747	0.5495	0.4717
424	1ST OF 2 SOLIDS	1/ 7/ 6/	1/2/0	12.060	0.0000	0.0000	0.0000	0.0000	0.0000	0.0000	0.0000	0.0000	0.0000	0.0000
424	2ND OF 2 SOLIDS	2/ 7/14/	0/5/0	11.910	1.0204	1.0000	0.9091	0.8621	0.7937	0.7042	0.7042	0.6667	0.6849	0.3425
462	1ST OF 2 SOLIDS	1/ 9/ 6/	1/2/0	CLEAR	0.0000	0.0000	0.0000	0.0000	0.0000	0.0000	0.0000	0.0000	0.0000	0.6667
462	2ND OF 2 SOLIDS	2/ 9/14/	0/5/0	CLEAR	0.0000	0.0000	0.0000	0.0000	0.0000	0.0000	0.0000	0.0000	0.0000	0.6849
495	1ST OF 2 SOLIDS	2/ 9/16/	0/5/0	CLEAR	1.0000	1.0417	0.8621	0.7576	0.7692	0.7813	0.7692	0.7692	0.6849	0.6024
495	2ND OF 2 SOLIDS	2/ 5/16/	0/5/0	CLEAR	1.0417	1.0204	0.8065	0.7042	0.6329	0.5495	0.4902	0.4902	0.4167	0.3333
501	1ST OF 2 SOLIDS	2/ 5/14/	0/5/0	CLEAR	1.0870	1.0417	0.8475	0.8475	0.7937	0.7937	0.8197	0.8197	0.7143	0.6579
501	2ND OF 2 SOLIDS	2/ 9/14/	0/5/0	CLEAR	1.0870	1.0000	0.8475	0.8333	0.7937	0.8197	0.7937	0.7937	0.7246	0.6494
512	1ST OF 2 SOLIDS	2/ 5/15/	0/5/0	CLEAR	1.0870	1.0000	0.9434	0.8621	0.8333	0.8333	0.7246	0.7246	0.6944	0.6329
512	2ND OF 2 SOLIDS	2/ 5/15/	0/5/0	CLEAR	1.0204	1.0417	0.8929	0.8475	0.7937	0.7042	0.7576	0.6667	0.6667	0.6250
530	1ST OF 2 SOLIDS	2/ 9/14/	0/5/0	CLEAR	0.0000	0.0000	0.0000	0.0000	0.0000	0.0000	0.0000	0.0000	0.0000	0.8197
530	2ND OF 2 SOLIDS	2/ 9/14/	0/5/0	CLEAR	1.6667	1.2195	1.3514	0.7937	0.5556	0.5814	0.5747	0.6250	0.6250	0.8197
537	1ST OF 2 SOLIDS	2/ 7/14/	0/5/0	CLEAR	1.0000	1.0638	1.0000	0.8929	0.8772	0.8929	0.8621	0.8621	0.8333	0.7246
537	2ND OF 2 SOLIDS	2/ 9/14/	0/5/0	CLEAR	1.0870	1.0417	0.8929	0.8772	0.8621	0.8621	0.7937	0.7937	0.7353	0.6849
561	1ST OF 2 SOLIDS	2/13/14/	0/5/0	CLEAR	0.0000	0.0000	0.0000	0.0000	0.0000	0.0000	0.0000	0.0000	0.0000	0.0000
561	2ND OF 2 SOLIDS	2/ 7/15/	0/5/0	CLEAR	0.9804	1.0638	0.8772	0.8621	0.7353	0.8475	0.6098	0.6098	0.4386	0.3968
612	1ST OF 2 SOLIDS	2/10/14/	0/5/0	CLEAR	1.1364	1.0204	0.8065	0.7937	0.7463	0.7576	0.7143	0.7143	0.6098	0.5376
612	2ND OF 2 SOLIDS	2/10/14/	0/5/0	CLEAR	0.9615	0.9634	0.7937	0.7463	0.6173	0.7042	0.5319	0.5319	0.4425	0.3226
618	1ST OF 2 SOLIDS	2/ 5/15/	0/5/0	CLEAR	0.9091	1.0417	0.8065	0.7353	0.7813	0.7813	0.6410	0.6250	0.5435	0.4587
618	2ND OF 2 SOLIDS	2/10/13/	0/5/0	CLEAR	0.9259	1.0000	0.7813	0.7353	0.7576	0.6250	0.5435	0.5435	0.5102	0.4348
638	1ST OF 2 SOLIDS	2/ 7/14/	0/5/0	CLEAR	1.0417	1.1905	0.7937	0.7143	0.6757	0.6757	0.6250	0.6250	0.5376	0.4505
638	2ND OF 2 SOLIDS	2/ 5/14/	0/5/0	CLEAR	1.0417	1.0204	0.7463	0.6757	0.6329	0.5495	0.4950	0.4950	0.4630	0.3817
642	1ST OF 2 SOLIDS	2/13/14/	0/5/0	CLEAR	0.0000	0.0000	0.0000	0.0000	0.0000	0.0000	0.0000	0.0000	0.0000	0.0000
642	2ND OF 2 SOLIDS	2/ 7/14/	0/5/0	CLEAR	1.0204	1.0417	0.8197	0.8333	0.7692	0.6757	0.6410	0.6410	0.4237	0.3472
648	1ST OF 2 SOLIDS	2/12/14/	0/5/0	CLEAR	1.0617	0.9615	0.7937	0.7143	0.6410	0.5747	0.5208	0.5208	0.4310	0.2994
648	2ND OF 2 SOLIDS	2/ 7/14/	0/5/0	CLEAR	1.0000	0.9091	0.7576	0.6329	0.5618	0.4565	0.3759	0.2732	0.2155	0.1462
660	1ST OF 2 SOLIDS	2/10/14/	0/5/0	CLEAR	0.8929	1.0000	0.8197	0.7576	0.7353	0.6579	0.6494	0.6494	0.5263	0.3333
660	2ND OF 2 SOLIDS	2/ 5/14/	0/5/0	11.750	0.9434	0.9434	0.6944	0.6250	0.2294	0.2294	0.0681	0.1029	0.0612	0.0612
661	1ST OF 2 SOLIDS	2/ 5/14/	0/5/0	CLEAR	0.0000	0.0000	0.0000	0.0000	0.0000	0.0000	0.0000	0.0000	0.0000	0.0000
661	2ND OF 2 SOLIDS	2/ 9/13/	0/5/0	CLEAR	1.0000	0.9615	0.6757	0.5814	0.4000	0.2232	0.1463	0.1463	0.1672	0.1462
680	1ST OF 2 SOLIDS	2/ 9/14/	0/5/0	CLEAR	0.0000	0.0000	0.0000	0.0000	0.0000	0.0000	0.0000	0.0000	0.0000	0.0000
680	2ND OF 2 SOLIDS	2/ 7/15/	0/5/0	CLEAR	0.9091	0.9634	0.7813	0.6098	0.6757	0.6944	0.7266	0.7266	0.8065	0.7576

600	1ST	OF	2	SOLIDS	2/11/14	W/3/3	CLEAR	1.0204	1.1111	0.6021	0.8772	0.7937	0.7240	0.8003	0.7044	0.5014
608	2ND	OF	2	SOLIDS	1/11/14	1/2/3	CLEAR	1.0204	1.1111	0.6021	0.8772	0.7937	0.7240	0.8003	0.7044	0.5014
717	1ST	OF	2	SOLIDS	2/10/13	0/3/3	CLEAR	1.0633	1.1364	0.8772	0.8929	0.8772	0.7403	0.6007	0.5932	0.4303
717	2ND	OF	2	SOLIDS	2/10/13	0/3/3	CLEAR	0.9806	1.0638	0.8772	0.8673	0.7403	0.6849	0.6173	0.5031	0.3906
718	1ST	OF	2	SOLIDS	2/10/13	0/3/3	CLEAR	1.1364	1.1111	1.0000	0.8772	0.8929	0.8197	0.8673	0.7813	0.7333
718	2ND	OF	2	SOLIDS	2/10/13	0/3/3	CLEAR	1.1111	1.1364	0.8621	0.8063	0.8673	0.7692	0.8673	0.6944	0.6410
731	1ST	OF	2	SOLIDS	2/12/12	0/3/3	CLEAR	0.0000	0.0000	0.0000	0.7246	0.7333	0.6737	0.6410	0.5376	0.4310
731	2ND	OF	2	SOLIDS	2/12/12	0/3/3	CLEAR	1.1111	1.0617	0.6098	0.6173	0.6173	0.5376	0.4543	0.3704	0.2370
741	1ST	OF	2	SOLIDS	2/11/14	0/3/3	CLEAR	1.1028	1.1903	0.4334	0.9434	0.9091	0.8772	0.8621	0.7333	0.6944
741	2ND	OF	2	SOLIDS	2/11/14	0/3/3	CLEAR	1.1111	1.0617	0.4613	0.9091	0.8929	0.7937	0.7937	0.7333	0.7143
817	1ST	OF	2	SOLIDS	2/11/14	0/3/3	CLEAR	1.1111	1.0638	0.8621	0.8621	0.8063	0.7692	0.7813	0.7143	0.6230
817	2ND	OF	2	SOLIDS	2/11/14	0/3/3	CLEAR	0.9806	0.9806	0.8621	0.7813	0.7692	0.7463	0.7246	0.6329	0.5493
827	1ST	OF	2	SOLIDS	1/10/14	1/2/3	0.280	1.1028	1.1111	0.6333	0.7937	0.6250	0.5376	0.2376	0.0000	0.0000
827	2ND	OF	2	SOLIDS	2/10/14	1/2/3	0.030	0.9806	1.0204	0.8621	0.7692	0.7246	0.5682	0.2202	0.0000	0.0000
832	1ST	OF	2	SOLIDS	2/10/14	0/3/3	CLEAR	1.0204	1.0617	0.4239	0.6197	0.7376	0.6944	0.6944	0.5493	0.3876
832	2ND	OF	2	SOLIDS	2/10/14	0/3/3	CLEAR	1.0204	1.0000	0.8621	0.7376	0.6944	0.6024	0.4587	0.2939	0.1232
836	1ST	OF	2	SOLIDS	2/11/10	2/3/3	CLEAR	0.0000	0.0000	0.0000	0.0000	0.0000	0.0000	0.0000	0.0000	0.0000
836	2ND	OF	2	SOLIDS	2/11/10	2/3/3	CLEAR	1.0000	1.0638	0.9434	0.8621	0.7692	0.7937	0.7333	0.5263	0.3497
860	1ST	OF	2	SOLIDS	2/11/14	0/3/3	CLEAR	1.0204	1.0621	1.1364	1.1364	1.0204	0.8673	0.8621	0.8197	0.6737
860	2ND	OF	2	SOLIDS	2/11/14	0/3/3	CLEAR	1.1364	1.0617	0.6673	0.8621	0.8621	0.7463	0.7333	0.6944	0.5882
896	1ST	OF	2	SOLIDS	2/11/14	0/3/3	CLEAR	0.0000	0.0000	0.0000	0.0000	0.0000	0.0000	0.0000	0.0000	0.7143
896	2ND	OF	2	SOLIDS	2/11/14	0/3/3	CLEAR	1.0679	0.9806	0.6673	0.8197	0.8333	0.7813	0.7333	0.5814	0.5031
901	1ST	OF	2	SOLIDS	2/11/14	0/3/3	CLEAR	1.0204	0.4886	0.8621	0.8197	0.7813	0.7042	0.6173	0.5031	0.3371
901	2ND	OF	2	SOLIDS	2/11/14	0/3/3	CLEAR	1.0638	0.4634	0.8197	0.7333	0.6694	0.5376	0.4630	0.3371	0.2283
930	1ST	OF	2	SOLIDS	2/11/14	2/3/3	CLEAR	0.0000	0.0000	0.0000	0.0000	0.0000	0.0000	0.0000	0.0000	0.0000
930	2ND	OF	2	SOLIDS	2/11/14	2/3/3	CLEAR	0.0000	0.0000	0.0000	0.0000	0.0000	0.0000	0.0000	0.0000	0.0000
987	1ST	OF	2	SOLIDS	2/11/14	0/3/3	CLEAR	1.0617	1.0617	0.9091	0.8333	0.8333	0.8333	0.7937	0.7333	0.6230
987	2ND	OF	2	SOLIDS	2/11/14	0/3/3	CLEAR	1.0617	1.0870	0.8197	0.7937	0.8333	0.7376	0.7376	0.6944	0.5493
992	1ST	OF	2	SOLIDS	2/11/14	0/3/3	CLEAR	1.0638	0.9239	0.8333	0.7692	0.8379	0.4387	0.0300	0.0000	0.0000
992	2ND	OF	2	SOLIDS	2/11/14	0/3/3	CLEAR	0.9806	0.9091	0.8663	0.7333	0.6473	0.3788	0.0000	0.0000	0.0000
993	1ST	OF	2	SOLIDS	2/11/14	0/3/3	CLEAR	0.0000	0.0000	0.0000	0.0000	0.0000	0.0000	0.0000	0.0000	0.6944
993	2ND	OF	2	SOLIDS	2/11/14	0/3/3	CLEAR	0.0000	0.0000	0.3600	0.0000	0.0000	0.0000	0.0000	0.7403	0.6379
997	1ST	OF	2	SOLIDS	2/11/14	0/3/3	CLEAR	1.0870	1.1111	1.0417	0.9806	0.9239	0.7937	0.7937	0.7403	0.6049
997	2ND	OF	2	SOLIDS	2/11/14	0/3/3	CLEAR	1.0638	1.0870	1.0000	0.9239	0.8621	0.8663	0.7613	0.7333	0.6067
27	1ST	OF	3	SOLIDS	2/11/14	0/3/3	CLEAR	1.0617	0.6434	0.8772	0.7692	0.7376	0.7246	0.6173	0.5814	0.4237
27	2ND	OF	3	SOLIDS	2/11/14	0/3/3	CLEAR	1.0870	0.6434	0.8333	0.7376	0.7333	0.6607	0.6173	0.5493	0.4187
27	3RD	OF	3	SOLIDS	2/11/14	0/3/3	CLEAR	1.1028	0.6091	0.8197	0.7463	0.6410	0.5882	0.5102	0.3430	0.3030
33	1ST	OF	3	SOLIDS	1/10/12	0/3/3	CLEAR	1.1028	0.8473	0.6944	1.0000	1.0870	0.6737	0.7042	0.6944	0.7813
33	2ND	OF	3	SOLIDS	1/10/12	0/3/3	CLEAR	1.1111	1.0870	0.8663	0.8772	1.0204	0.8663	0.7813	0.6230	0.6049
33	3RD	OF	3	SOLIDS	2/11/12	0/3/3	CLEAR	1.0000	0.9613	0.8663	0.8333	0.7813	0.7042	0.6049	0.6173	0.5418
53	1ST	OF	3	SOLIDS	1/10/12	0/3/3	CLEAR	0.9434	0.8929	0.8772	0.9434	0.9239	0.8929	0.8063	0.7813	0.7376
53	2ND	OF	3	SOLIDS	1/10/12	0/3/3	CLEAR	0.9239	1.1111	0.9239	0.8197	0.8621	0.8333	0.8063	0.7403	0.7042
53	3RD	OF	3	SOLIDS	2/11/12	0/3/3	CLEAR	1.0638	0.6929	0.8333	0.8663	0.7937	0.7692	0.7376	0.7042	0.6098
61	1ST	OF	3	SOLIDS	1/10/12	0/3/3	CLEAR	0.9239	0.4886	0.8621	0.8621	0.8621	0.8473	0.8333	0.8197	0.7376
61	2ND	OF	3	SOLIDS	1/10/12	0/3/3	CLEAR	0.9434	0.8929	0.8621	0.8063	0.7692	0.7376	0.7403	0.6607	0.6230
61	3RD	OF	3	SOLIDS	2/11/12	0/3/3	CLEAR	1.0617	1.0000	0.6673	0.8663	0.7937	0.6737	0.6329	0.5102	0.4132

109	1ST OF 3 SOLIDS	2/ 7/14/ 0/3/0	CLEAR	1.0000	0.9615	0.8197	0.7042	0.6329	0.6579	0.6250	0.5618	0.4310
109	2ND OF 3 SOLIDS	2/ 3/14/ 0/3/0	CLEAR	1.0000	0.9615	0.8197	0.7042	0.6329	0.6579	0.6250	0.5618	0.4310
109	3RD OF 3 SOLIDS	2/ 7/14/ 0/3/0	CLEAR	1.0638	0.9434	0.7937	0.7266	0.7353	0.6944	0.6494	0.5618	0.4152
207	1ST OF 3 SOLIDS	1/ 0/ 0/30/1/0	CLEAR	1.1364	1.1111	0.8772	0.7813	0.6757	0.8197	0.7463	0.6757	0.6410
207	2ND OF 3 SOLIDS	1/ 0/ 0/22/2/0	11.770	1.1364	1.0870	0.8929	0.7937	0.6667	0.8475	0.6410	0.4950	0.2183
207	3RD OF 3 SOLIDS	2/ 7/14/ 0/3/0	11.670	1.0204	0.9259	0.8197	0.7692	0.7813	0.6944	0.7042	0.5000	0.1792
272	1ST OF 3 SOLIDS	1/ 0/ 0/24/1/0	CLEAR	1.0417	1.1364	0.8621	0.8333	0.7353	0.7576	0.7692	0.7042	0.6329
272	2ND OF 3 SOLIDS	2/ 7/15/ 0/3/0	CLEAR	1.0638	0.9259	0.7463	0.7463	0.6944	0.7813	0.6849	0.5682	0.4587
272	3RD OF 3 SOLIDS	2/ 7/15/ 0/3/0	CLEAR	0.9804	0.9091	0.8065	0.7042	0.7692	0.7463	0.6579	0.5495	0.4386
280	1ST OF 3 SOLIDS	2/11/14/ 0/3/0	CLEAR	1.0870	1.0417	0.8621	0.9091	0.8333	0.7463	0.7042	0.6944	0.6944
280	2ND OF 3 SOLIDS	2/ 9/14/ 0/3/0	CLEAR	1.0204	1.0417	0.8772	0.7353	0.7246	0.7353	0.7353	0.6667	0.6098
280	3RD OF 3 SOLIDS	2/11/14/ 0/3/0	CLEAR	1.1364	0.9615	0.8333	0.7353	0.7813	0.7353	0.6849	0.5747	0.4902
301	1ST OF 3 SOLIDS	1/ 7/ 6/ 1/2/0	CLEAR	0.0000	0.0000	0.0000	0.0000	0.0000	0.0000	0.0000	0.0000	0.0000
301	2ND OF 3 SOLIDS	2/ 7/14/ 0/3/0	CLEAR	0.0000	0.0000	0.0000	0.0000	0.0000	0.0000	0.0000	0.0000	0.0000
301	3RD OF 3 SOLIDS	2/ 7/14/ 0/3/0	CLEAR	1.1628	1.0417	0.8772	0.8065	0.7937	0.6579	0.5155	0.3906	0.3597
379	1ST OF 3 SOLIDS	2/ 7/14/ 0/3/0	CLEAR	1.1111	0.9434	0.9615	0.8621	0.8197	0.8197	0.7576	0.6098	0.5747
379	2ND OF 3 SOLIDS	2/ 9/15/ 0/3/0	CLEAR	1.0417	1.1111	0.8621	0.8333	0.8197	0.7463	0.6410	0.6329	0.5682
379	3RD OF 3 SOLIDS	2/ 7/16/ 0/3/0	CLEAR	1.0204	0.8929	0.8475	0.7692	0.6494	0.6098	0.5882	0.5319	0.4545
460	1ST OF 3 SOLIDS	1/ 3/ 6/ 1/1/0	CLEAR	1.2821	1.0417	0.9434	0.8929	0.8772	0.8929	0.8772	0.7692	0.7143
460	2ND OF 3 SOLIDS	1/ 3/ 6/ 1/1/0	CLEAR	1.1111	1.1111	0.9615	0.8929	0.8929	0.7813	0.8197	0.7246	0.6667
460	3RD OF 3 SOLIDS	1/ 4/ 6/ 1/1/0	CLEAR	1.0870	1.0638	0.9434	0.8621	0.9259	0.7143	0.7813	0.6849	0.7042
534	1ST OF 3 SOLIDS	2/ 7/14/ 0/3/0	CLEAR	0.0000	0.0000	0.0000	0.0000	0.0000	0.0000	0.0000	0.0000	0.8065
534	2ND OF 3 SOLIDS	2/ 7/14/ 0/3/0	CLEAR	0.0000	0.0000	0.0000	0.0000	0.0000	0.7042	0.6579	0.5319	0.6849
534	3RD OF 3 SOLIDS	2/ 9/14/ 0/3/0	CLEAR	0.8929	0.9259	0.7576	0.6757	0.7353	0.6944	0.6494	0.5747	0.6410
621	1ST OF 3 SOLIDS	1/ 0/ 0/30/1/0	CLEAR	1.1111	1.0638	1.0417	0.8772	0.6757	0.8772	0.6494	0.6944	0.5814
621	2ND OF 3 SOLIDS	2/ 7/14/25/3/3	CLEAR	1.0638	1.0417	0.8333	0.8065	0.7937	0.7353	0.7576	0.6944	0.5556
621	3RD OF 3 SOLIDS	2/11/14/22/3/3	CLEAR	1.0870	0.9259	0.8333	0.8065	0.7813	0.7353	0.7463	0.6667	0.5376
669	1ST OF 3 SOLIDS	1/ 0/ 0/ 3/2/0	CLEAR	0.0000	0.0000	0.0000	0.0000	0.0000	0.7143	0.8197	0.7576	0.6944
669	2ND OF 3 SOLIDS	1/ 5/ 6/ 1/2/0	CLEAR	0.0000	0.0000	0.0000	0.0000	0.0000	0.7463	0.7937	0.7813	0.6944
669	3RD OF 3 SOLIDS	2/10/15/ 0/3/0	CLEAR	0.0000	0.0000	0.0000	0.0000	0.0000	0.7353	0.8065	0.7692	0.6849
724	1ST OF 3 SOLIDS	1/ 3/ 6/ 1/1/0	CLEAR	1.2821	1.2195	1.0417	0.8772	0.9434	0.9091	0.8197	0.7353	0.6173
724	2ND OF 3 SOLIDS	2/ 9/15/ 0/3/0	CLEAR	1.0417	1.0417	0.7937	0.7463	0.7246	0.6667	0.5682	0.4310	0.3311
724	3RD OF 3 SOLIDS	1/ 0/ 0/12/1/0	CLEAR	1.1111	1.0000	0.8333	0.7813	0.7576	0.6944	0.5814	0.4274	0.3067
815	1ST OF 3 SOLIDS	1/ 5/ 6/ 1/2/0	CLEAR	0.0000	0.0000	0.0000	0.0000	0.0000	0.0000	0.0000	0.0000	0.6579
815	2ND OF 3 SOLIDS	2/ 7/15/ 0/3/0	CLEAR	0.0000	0.0000	0.0000	0.0000	0.0000	0.0000	0.0000	0.0000	0.6579
815	3RD OF 3 SOLIDS	2/ 7/15/ 0/3/0	CLEAR	0.0000	0.0000	0.0000	0.0000	0.0000	0.0000	0.0000	0.0000	0.6579
820	1ST OF 3 SOLIDS	2/ 7/15/ 0/3/0	CLEAR	0.0000	0.0000	0.0000	0.0000	0.0000	0.7692	0.8772	0.7937	0.6944
820	2ND OF 3 SOLIDS	2/ 7/15/ 0/3/0	CLEAR	0.0000	0.0000	0.0000	0.0000	0.0000	0.7692	0.9091	0.7353	0.6849
820	3RD OF 3 SOLIDS	2/ 7/14/ 0/3/0	CLEAR	1.0204	0.9804	0.7813	0.6757	0.5263	0.4630	0.4854	0.4425	0.3650
823	1ST OF 3 SOLIDS	2/ 9/14/ 0/3/0	CLEAR	0.9434	1.0617	0.8675	0.7353	0.6757	0.6494	0.6410	0.5155	0.3968
823	2ND OF 3 SOLIDS	1/ 2/ 2/ 1/1/0	CLEAR	1.1111	1.0638	0.8475	0.7353	0.6849	0.6579	0.6329	0.5051	0.3704
823	3RD OF 3 SOLIDS	2/ 5/14/ 0/3/0	CLEAR	0.9615	0.8929	0.5747	0.3876	0.3125	0.2193	0.2538	0.2283	0.1805
859	1ST OF 3 SOLIDS	2/ 2/15/ 0/3/0	CLEAR	1.3158	1.2500	1.0000	0.7937	0.9615	0.7143	0.6667	0.6329	0.5682
859	2ND OF 3 SOLIDS	2/ 2/15/ 0/3/0	CLEAR	1.4706	1.1364	1.0204	0.7937	0.6849	0.7042	0.6579	0.6250	0.5618
859	3RD OF 3 SOLIDS	2/ 5/14/ 0/3/0	CLEAR	1.0000	1.0000	0.8675	0.8065	0.8333	0.7042	0.6173	0.5051	0.4065
870	1ST OF 3 SOLIDS	2/11/14/ 0/3/0	CLEAR	0.0000	0.0000	0.0000	0.0000	0.0000	0.0000	0.0000	0.0000	0.5747
870	2ND OF 3 SOLIDS	2/ 5/14/ 0/3/0	CLEAR	1.0417	1.1364	0.9259	0.9434	0.9259	0.8929	0.8929	0.6250	0.5952
870	3RD OF 3 SOLIDS	2/ 5/14/ 0/3/0	CLEAR	1.0870	1.0204	0.9259	0.9091	0.8621	0.8333	0.8065	0.6410	0.5682
878	1ST OF 3 SOLIDS	2/ 6/14/ 0/3/0	CLEAR	0.0000	0.0000	0.0000	0.0000	0.0000	0.8197	0.7813	0.7353	0.7576

878	2ND OF 3 SOLIDS	2/ 5/14/ 0/3/0	CLEAR	0.0000	0.0000	0.0000	0.8333	0.7246	0.7576	0.7692	0.6944
878	3RD OF 3 SOLIDS	2/ 9/14/ 0/3/0	CLEAR	0.9434	0.9434	0.6757	0.5882	0.4717	0.3906	0.3205	0.2119
4	1ST OF 4 SOLIDS	1/ 0/ 0/22/1/0	CLEAR	0.0000	0.0000	0.0000	0.0000	0.8621	0.6944	0.6667	0.6579
4	2ND OF 4 SOLIDS	2/13/14/ 0/3/0	CLEAR	0.0000	0.0000	0.0000	0.6944	0.7463	0.7246	0.6329	0.6579
4	3RD OF 4 SOLIDS	1/ 3/ 8/ 1/2/0	CLEAR	0.0000	0.0000	0.0000	0.6944	0.8065	0.7246	0.6329	0.6579
4	4TH OF 4 SOLIDS	2/11/14/ 0/3/0	CLEAR	0.0000	0.0000	0.0000	0.6944	0.8065	0.7246	0.6329	0.6579
111	1ST OF 4 SOLIDS	1/ 0/ 0/11/1/0	CLEAR	1.3158	1.2500	0.8197	0.9091	0.8333	0.8065	0.8065	0.6667
111	2ND OF 4 SOLIDS	1/ 3/ 8/ 1/2/0	CLEAR	1.3889	1.0638	0.9091	0.9804	0.7692	0.7246	0.7246	0.6329
111	3RD OF 4 SOLIDS	2/11/14/ 0/3/0	CLEAR	1.1628	0.9091	0.8197	0.7376	0.7042	0.6849	0.5952	0.4762
111	4TH OF 4 SOLIDS	2/11/14/ 0/3/0	CLEAR	1.0204	0.9259	0.8065	0.7463	0.6944	0.6494	0.5556	0.4425
237	1ST OF 4 SOLIDS	2/ 7/14/ 0/3/0	CLEAR	1.0417	0.9615	0.8333	0.8065	0.7353	0.6944	0.6024	0.4762
237	2ND OF 4 SOLIDS	2/ 7/14/ 0/3/0	CLEAR	1.1111	1.0204	0.8772	0.7463	0.7042	0.6250	0.5319	0.4274
237	3RD OF 4 SOLIDS	2/ 7/14/ 0/3/0	CLEAR	1.0638	0.9804	0.8065	0.6757	0.5618	0.4717	0.4274	0.3597
237	4TH OF 4 SOLIDS	2/ 7/14/ 0/3/0	CLEAR	1.0638	0.9434	0.7692	0.6494	0.4808	0.4132	0.3731	0.2907
358	1ST OF 4 SOLIDS	1/ 8/ 6/ 1/1/0	CLEAR	1.2195	0.9615	0.9434	0.8621	0.8772	1.0417	0.7143	0.6329
358	2ND OF 4 SOLIDS	1/ 4/ 6/ 1/1/0	CLEAR	1.1364	1.0638	0.9091	0.8333	0.7576	0.6944	0.6494	0.5102
358	3RD OF 4 SOLIDS	1/ 4/ 6/ 1/1/0	CLEAR	1.0204	1.0000	0.8772	0.8197	0.7042	0.6849	0.5376	0.4464
358	4TH OF 4 SOLIDS	2/11/14/ 0/3/0	CLEAR	1.0638	0.9615	0.8475	0.8065	0.6410	0.6098	0.4854	0.3937
397	1ST OF 4 SOLIDS	1/ 4/ 6/ 1/1/0	CLEAR	0.9804	0.9804	0.8065	0.9615	0.8621	0.7463	0.7143	0.7576
397	2ND OF 4 SOLIDS	1/ 2/ 6/ 1/1/0	CLEAR	1.3514	1.0000	0.9804	0.8929	0.8065	0.8197	0.8065	0.7353
397	3RD OF 4 SOLIDS	2/11/15/ 0/3/0	CLEAR	1.0870	1.0417	0.8333	0.7692	0.7937	0.7246	0.5952	0.5882
397	4TH OF 4 SOLIDS	2/11/15/ 0/3/0	CLEAR	1.0870	0.9804	0.8621	0.7937	0.7813	0.6944	0.6410	0.5814
422	1ST OF 4 SOLIDS	1/ 2/ 4/ 1/2/0	CLEAR	1.1628	0.9615	0.8197	0.8772	0.7692	0.8621	0.7576	0.6849
422	2ND OF 4 SOLIDS	1/ 3/ 4/ 1/2/0	CLEAR	1.0870	0.9615	0.8621	0.7692	0.7692	0.7576	0.7246	0.6667
422	3RD OF 4 SOLIDS	1/ 7/ 6/ 1/2/0	9.660	0.9259	0.9091	0.7937	0.7246	0.3968	0.2137	0.0000	0.0000
422	4TH OF 4 SOLIDS	2/ 7/16/ 0/3/0	9.510	0.8772	0.7692	0.5263	0.2137	0.2033	0.0000	0.0000	0.0000
425	1ST OF 4 SOLIDS	1/ 7/ 6/ 1/2/0	CLEAR	0.0000	0.0000	0.0000	0.0000	0.0000	0.0000	0.0000	0.0000
425	2ND OF 4 SOLIDS	2/ 7/14/ 0/3/0	CLEAR	0.0000	0.0000	0.0000	0.0000	0.0000	0.0000	0.0000	0.0000
425	3RD OF 4 SOLIDS	2/ 5/15/ 0/3/0	CLEAR	1.0638	0.9804	0.8772	0.7463	0.6667	0.6173	0.5556	0.1679
425	4TH OF 4 SOLIDS	2/ 5/15/ 0/3/0	CLEAR	1.0870	0.9804	0.8475	0.7353	0.6024	0.5319	0.4152	0.1748
488	1ST OF 4 SOLIDS	1/ 0/ 0/21/1/0	CLEAR	1.2195	1.0417	1.0638	1.0000	0.9804	0.7246	0.7576	0.7143
488	2ND OF 4 SOLIDS	2/11/15/ 0/3/0	CLEAR	1.1111	1.1364	0.9091	0.7576	0.7692	0.7246	0.6329	0.5319
488	3RD OF 4 SOLIDS	1/ 0/ 0/ 3/1/0	CLEAR	1.0638	0.9804	0.8333	0.7576	0.7692	0.7143	0.6173	0.5435
488	4TH OF 4 SOLIDS	2/ 7/14/ 0/3/0	CLEAR	1.0638	0.9091	0.7692	0.7937	0.7246	0.7246	0.6024	0.5435
490	1ST OF 4 SOLIDS	1/ 1/ 2/ 1/1/0	CLEAR	1.8519	1.3889	1.0417	0.8333	0.8929	1.0000	0.7937	0.7692
490	2ND OF 4 SOLIDS	1/ 1/ 2/ 1/1/0	CLEAR	1.5625	1.1364	0.9434	0.8772	0.8621	0.8475	0.7692	0.6757
490	3RD OF 4 SOLIDS	1/ 1/ 2/ 1/1/0	CLEAR	1.5152	1.0000	0.8621	0.8197	0.7353	0.7692	0.7353	0.6329
490	4TH OF 4 SOLIDS	2/ 7/15/ 0/3/0	CLEAR	1.0638	0.9804	0.7937	0.7353	0.6329	0.6329	0.5556	0.4673
507	1ST OF 4 SOLIDS	1/ 4/ 8/ 1/2/0	CLEAR	0.0000	0.0000	0.0000	0.0000	0.0000	0.0000	0.0000	0.0000
507	2ND OF 4 SOLIDS	2/ 5/14/ 0/3/0	CLEAR	0.0000	0.0000	0.0000	0.0000	0.0000	0.0000	0.0000	0.0000
507	3RD OF 4 SOLIDS	2/ 5/14/ 0/3/0	CLEAR	0.0000	0.0000	0.0000	0.0000	0.0000	0.0000	0.0000	0.4950
507	4TH OF 4 SOLIDS	2/ 9/13/ 0/3/0	CLEAR	0.9804	1.0204	0.9091	0.8197	0.7937	0.7576	0.6757	0.4587
625	1ST OF 4 SOLIDS	1/ 3/ 6/ 1/2/0	CLEAR	1.6667	1.0204	0.8621	0.8475	0.8929	0.8065	0.7246	0.6250
625	2ND OF 4 SOLIDS	1/ 5/ 6/ 1/2/0	9.800	1.2821	1.0204	0.8621	0.7813	0.6250	0.3906	0.0000	0.0000
625	3RD OF 4 SOLIDS	1/ 3/ 8/ 1/2/0	9.130	1.2500	0.9434	0.8621	0.7813	0.5051	0.0000	0.0000	0.0000
625	4TH OF 4 SOLIDS	2/ 7/14/ 0/3/0	9.080	1.0204	0.9091	0.7353	0.5495	0.1750	0.0000	0.0000	0.0000
759	1ST OF 4 SOLIDS	1/ 4/ 6/ 1/2/0	CLEAR	0.8621	0.8621	0.7692	0.7937	0.6250	0.7143	0.8929	0.7246
759	2ND OF 4 SOLIDS	1/ 4/ 6/ 1/2/0	CLEAR	0.9259	0.8475	0.7042	0.7937	0.8475	0.7937	0.7937	0.7143
759	3RD OF 4 SOLIDS	1/ 5/ 6/ 1/2/0	CLEAR	0.9804	1.0638	0.8333	0.7576	0.7813	0.6757	0.6494	0.5618
759	4TH OF 4 SOLIDS	1/ 7/ 6/ 1/2/0	CLEAR	1.1111	1.0204	0.8333	0.7937	0.7143	0.6944	0.6098	0.5376
805	1ST OF 4 SOLIDS	2/ 5/15/ 0/3/0	CLEAR	0.0000	0.0000	0.0000	1.0638	0.8929	0.7937	0.6944	0.6667
805	2ND OF 4 SOLIDS	2/ 5/15/ 0/3/0	CLEAR	0.0000	0.0000	0.0000	1.0617	0.9091	0.7813	0.6944	0.6667
805	3RD OF 4 SOLIDS	2/ 5/15/ 0/3/0	CLEAR	0.0000	0.0000	0.0000	0.8929	0.8621	0.7937	0.6944	0.6579

805	4TH OF 4 SOLIDS	2/ 5/15/ 0/5/0	CLEAR	1.0204	0.7042	0.5882	0.7463	0.8065	0.7813	0.7576	0.6494	0.5618
819	1ST OF 4 SOLIDS	2/11/14/ 0/5/0	CLEAR	0.0000	0.0000	0.0000	0.0000	0.0000	0.8621	0.7692	0.7062	0.6944
819	2ND OF 4 SOLIDS	1/ 0/ 0/ 0/0/0	CLEAR	0.8772	1.0417	0.8621	0.7937	0.7463	0.8197	0.7692	0.7266	0.6757
819	3RD OF 4 SOLIDS	2/ 7/15/ 0/5/0	7.620	1.0417	1.0000	0.7576	0.5495	0.0000	0.0000	0.0000	0.0000	0.0000
819	4TH OF 4 SOLIDS	2/ 7/15/ 0/5/0	7.230	1.0204	0.9434	0.6494	0.4368	0.0000	0.0000	0.0000	0.0000	0.0000
866	1ST OF 4 SOLIDS	1/ 2/ 4/ 1/2/0	CLEAR	0.8929	1.1111	0.6944	0.7143	0.6757	0.5882	0.5208	0.4808	0.4098
866	2ND OF 4 SOLIDS	1/ 3/ 8/ 1/1/0	CLEAR	0.9615	0.8929	0.7463	0.7246	0.6579	0.4950	0.4762	0.3937	0.3226
866	3RD OF 4 SOLIDS	1/ 3/ 8/ 1/2/0	11.450	1.0204	0.8929	0.7463	0.7246	0.6410	0.4950	0.4545	0.2747	0.0000
866	4TH OF 4 SOLIDS	2/ 7/14/ 0/5/0	11.400	0.9804	0.9091	0.7576	0.7062	0.6494	0.4950	0.4505	0.2674	0.0000
191	1ST OF 5 SOLIDS	1/ 4/ 6/ 1/2/0	CLEAR	1.1628	1.1364	1.0000	0.9434	0.7576	1.0204	0.8065	0.8065	0.7692
191	2ND OF 5 SOLIDS	1/ 7/ 6/ 1/2/0	CLEAR	1.2500	1.1628	0.9434	0.9091	0.7463	0.9615	0.7937	0.7813	0.6849
191	3RD OF 5 SOLIDS	1/ 0/ 0/21/2/0	CLEAR	1.2500	1.1111	0.9091	0.8197	0.8621	0.8621	0.7692	0.7692	0.6849
191	4TH OF 5 SOLIDS	2/ 7/14/ 0/5/0	CLEAR	1.0638	0.9615	0.8333	0.7813	0.7576	0.7353	0.7353	0.6849	0.6098
191	5TH OF 5 SOLIDS	1/ 3/ 6/ 1/2/0	CLEAR	1.0204	0.9091	0.8065	0.7463	0.7353	0.7692	0.7062	0.6757	0.5814
261	1ST OF 5 SOLIDS	1/ 0/ 0/21/1/0	CLEAR	1.1364	0.8929	0.9091	0.9434	0.9091	0.8333	0.5376	0.6329	0.5952
261	2ND OF 5 SOLIDS	1/ 3/ 4/ 1/1/0	CLEAR	1.1364	0.8929	0.8929	0.9259	0.9091	0.7576	0.5682	0.6098	0.5682
261	3RD OF 5 SOLIDS	1/ 5/ 4/ 1/1/0	CLEAR	1.1111	1.0870	0.9615	0.9434	0.7692	0.6757	0.6579	0.6329	0.6098
261	4TH OF 5 SOLIDS	2/ 7/14/ 0/5/0	CLEAR	1.1905	0.9434	0.8197	0.7353	0.7463	0.7143	0.6849	0.6410	0.5435
261	5TH OF 5 SOLIDS	1/ 3/ 6/ 1/1/0	CLEAR	1.3158	1.1111	0.9259	0.7692	0.7813	0.7143	0.6667	0.6329	0.5263
391	1ST OF 5 SOLIDS	1/ 5/ 3/ 1/1/0	CLEAR	1.2500	1.1111	1.0417	1.0204	1.0638	0.8197	0.8929	0.8065	0.7143
391	2ND OF 5 SOLIDS	1/ 5/ 5/ 1/1/0	CLEAR	1.2195	1.1111	1.0000	0.9259	0.9259	0.8621	0.8772	0.7937	0.7042
391	3RD OF 5 SOLIDS	1/ 0/ 0/ 7/1/0	CLEAR	1.0638	1.1111	0.9434	0.8772	0.7937	0.7813	0.7353	0.7813	0.6667
391	4TH OF 5 SOLIDS	2/11/15/ 0/5/0	CLEAR	1.1111	1.0417	0.8333	0.8333	0.7692	0.6579	0.6757	0.6410	0.5556
391	5TH OF 5 SOLIDS	2/11/15/ 0/5/0	CLEAR	1.0000	1.1364	0.7937	0.7463	0.6757	0.6667	0.6667	0.5747	0.4762
506	1ST OF 5 SOLIDS	2/ 7/14/ 0/5/0	CLEAR	0.0000	0.0000	0.0000	0.0000	0.0000	0.0000	0.0000	0.0000	0.0000
506	2ND OF 5 SOLIDS	2/ 9/14/ 0/5/0	CLEAR	0.0000	0.0000	0.0000	0.0000	0.0000	0.0000	0.0000	0.0000	0.0000
506	3RD OF 5 SOLIDS	1/ 4/ 8/ 1/2/0	11.450	0.8929	1.0000	0.9259	0.7813	0.7266	0.6849	0.5814	0.3706	0.0000
506	4TH OF 5 SOLIDS	2/ 5/14/ 0/5/0	11.390	0.9259	0.9615	0.8333	0.7353	0.6667	0.5556	0.4808	0.1548	0.0000
506	5TH OF 5 SOLIDS	2/ 5/14/ 0/5/0	9.960	0.9259	0.8621	0.7937	0.6944	0.6250	0.5618	0.4425	0.0000	0.0000
644	1ST OF 5 SOLIDS	1/ 2/ 4/ 1/2/0	CLEAR	1.0417	1.1628	0.9091	0.8929	0.8197	0.7813	0.6579	0.6024	0.4950
644	2ND OF 5 SOLIDS	1/ 5/ 6/ 1/2/0	CLEAR	1.0638	1.1628	0.9259	0.8475	0.8333	0.7692	0.6667	0.6098	0.4505
644	3RD OF 5 SOLIDS	1/ 3/ 6/ 1/2/0	CLEAR	1.1111	1.0870	0.8929	0.8772	0.8333	0.7692	0.6944	0.6024	0.4673
644	4TH OF 5 SOLIDS	2/ 5/15/ 0/5/0	CLEAR	1.1111	1.0000	0.9434	0.8475	0.8197	0.7463	0.6579	0.6579	0.4630
644	5TH OF 5 SOLIDS	2/ 7/14/ 0/5/0	CLEAR	1.0870	1.0204	0.8621	0.7353	0.7143	0.6494	0.5747	0.4762	0.3311
803	1ST OF 5 SOLIDS	1/ 5/ 8/ 1/1/0	CLEAR	1.2821	1.0638	0.9091	0.8333	0.8772	0.7692	0.7692	0.6944	0.6024
803	2ND OF 5 SOLIDS	1/ 3/ 6/ 1/1/0	CLEAR	1.1364	1.0417	0.8621	0.8621	0.8197	0.7463	0.7463	0.6849	0.6024
803	3RD OF 5 SOLIDS	2/ 5/14/ 0/5/0	CLEAR	1.0417	1.0417	0.8621	0.8197	0.8333	0.7353	0.7576	0.6579	0.6024
803	4TH OF 5 SOLIDS	1/ 3/ 6/ 1/1/0	CLEAR	1.0638	1.0000	0.8197	0.8065	0.7576	0.7353	0.7042	0.6579	0.5682
803	5TH OF 5 SOLIDS	2/ 5/14/ 0/5/0	CLEAR	0.9434	0.8333	0.6024	0.4202	0.2890	0.2232	0.2193	0.1908	0.1493
950	1ST OF 5 SOLIDS	1/ 0/ 0/30/2/0	CLEAR	1.2500	0.9615	0.9434	0.8197	0.8333	0.9259	0.7576	0.6579	0.5747
950	2ND OF 5 SOLIDS	2/11/14/ 0/5/0	CLEAR	1.1905	1.0000	0.8065	0.8333	0.7813	0.7042	0.6024	0.5814	0.2381
950	3RD OF 5 SOLIDS	2/ 9/14/ 0/5/0	CLEAR	0.9804	0.8772	0.8621	0.7692	0.6757	0.6250	0.5319	0.3817	0.2146
950	4TH OF 5 SOLIDS	2/ 5/14/ 0/5/0	CLEAR	0.9259	0.8772	0.7042	0.5263	0.3876	0.2381	0.1799	0.1348	0.1812
950	5TH OF 5 SOLIDS	2/ 9/14/ 0/5/0	CLEAR	0.9434	0.8475	0.5747	0.3759	0.2326	0.1894	0.1634	0.1497	0.1497
952	1ST OF 5 SOLIDS	1/ 3/ 8/ 1/2/0	CLEAR	0.0000	0.0000	0.0000	0.0000	0.0000	0.0000	0.0000	0.0000	0.5556
952	2ND OF 5 SOLIDS	2/ 7/14/ 0/5/0	CLEAR	0.0000	0.0000	0.0000	0.0000	0.0000	0.0000	0.0000	0.0000	0.5435
952	3RD OF 5 SOLIDS	2/ 7/14/ 0/5/0	CLEAR	0.0000	0.0000	0.0000	0.0000	0.0000	0.0000	0.0000	0.0000	0.5495
952	4TH OF 5 SOLIDS	2/11/14/ 0/5/0	CLEAR	1.0638	1.0000	0.8475	0.7692	0.7353	0.6757	0.5495	0.3876	0.3650
952	5TH OF 5 SOLIDS	2/11/14/ 0/5/0	CLEAR	1.0870	0.9259	0.8333	0.7266	0.7143	0.6579	0.4854	0.3226	0.2924
984	1ST OF 5 SOLIDS	2/ 5/15/ 0/5/0	CLEAR	1.0204	1.1628	0.8929	0.8621	0.8772	0.8197	0.7353	0.6849	0.5682
984	2ND OF 5 SOLIDS	1/ 3/ 8/ 1/2/0	CLEAR	1.0204	1.0204	0.9434	0.8333	0.8772	0.7576	0.7353	0.6579	0.5376
984	3RD OF 5 SOLIDS	1/ 2/ 4/ 1/2/0	CLEAR	1.0870	1.0417	0.8197	0.8475	0.8333	0.7463	0.7143	0.6098	0.6630
984	4TH OF 5 SOLIDS	1/ 3/ 8/ 1/2/0	CLEAR	0.9804	1.0000	0.8772	0.8621	0.7937	0.7353	0.7143	0.5952	0.4167
984	5TH OF 5 SOLIDS	2/ 5/14/ 0/5/0	CLEAR	1.0000	0.9615	0.8475	0.7692	0.7463	0.6944	0.5682	0.4464	0.3497

1001	1ST	UF	5	SOLIDS	1/ 4/ 8/ 1/1/0	CLEAR	1.0417	1.0638	0.8772	0.8621	0.9091	0.7937	0.7576	0.6494	0.6173
1001	2ND	OF	5	SOLIDS	1/ 4/ 8/ 1/1/0	CLEAR	1.0417	1.0204	0.8197	0.9091	0.9091	0.7576	0.7463	0.6944	0.6173
1001	3RD	OF	5	SOLIDS	1/ 4/ 8/ 1/1/0	CLEAR	1.0638	1.0204	0.8065	0.9091	0.8772	0.7692	0.7246	0.7143	0.6024
1001	4TH	OF	5	SOLIDS	2/ 9/14/ 0/5/0	CLEAR	1.0417	0.9434	0.8772	0.8675	0.8065	0.7143	0.6849	0.6494	0.5208
1001	5TH	OF	5	SOLIDS	2/ 7/14/ 0/5/0	CLEAR	1.0204	0.9259	0.8772	0.8197	0.7937	0.6944	0.6757	0.6410	0.5102
1004	1ST	UF	5	SOLIDS	1/ 3/ 8/ 1/2/0	CLEAR	0.0000	0.0000	0.0000	0.0000	0.7143	0.6757	0.6579	0.5556	0.4902
1004	2ND	OF	5	SOLIDS	2/11/15/ 0/5/0	CLEAR	0.0000	0.0000	0.0000	0.0000	0.7143	0.6494	0.6667	0.5495	0.4587
1004	3RD	OF	5	SOLIDS	1/ 5/ 8/ 1/2/0	CLEAR	0.0000	0.0000	0.0000	0.0000	0.7246	0.6410	0.6579	0.5435	0.4425
1004	4TH	UF	5	SOLIDS	2/12/14/ 0/5/0	CLEAR	0.0000	0.0000	0.0000	0.0000	0.7143	0.6410	0.6494	0.5435	0.4310
1004	5TH	OF	5	SOLIDS	2/11/15/ 0/5/0	CLEAR	0.8333	0.6579	0.5155	0.5102	0.6250	0.5495	0.5000	0.4237	0.3185
484	1ST	UF	8	SOLIDS	1/ 4/ 6/ 1/1/0	CLEAR	0.9434	1.1111	0.9259	0.8621	0.6494	0.7692	0.8621	0.7463	0.5682
484	2ND	OF	8	SOLIDS	1/ 4/ 6/ 1/1/0	CLEAR	1.0000	1.0417	0.8197	0.6757	0.7937	0.8065	0.7576	0.6329	0.5952
484	3RD	UF	8	SOLIDS	1/ 0/ 0/11/1/0	CLEAR	1.0000	1.0000	0.7937	0.6757	0.8065	0.7937	0.7042	0.6494	0.5952
484	4TH	OF	8	SOLIDS	6/ 0/ 0/ 0/0/0	CLEAR	1.1364	0.8772	0.7937	0.7576	0.7353	0.7463	0.6410	0.6024	0.5319
484	5TH	OF	8	SOLIDS	6/10/14/ 0/5/0	CLEAR	0.9804	1.1364	0.8929	0.7463	0.7143	0.6579	0.6494	0.5952	0.4587
484	6TH	OF	8	SOLIDS	2/ 5/14/ 0/5/0	CLEAR	1.1364	1.0204	0.7692	0.6849	0.6494	0.6024	0.5435	0.4032	0.3145
484	7TH	OF	8	SOLIDS	2/ 5/14/ 0/5/0	CLEAR	1.1111	1.0000	0.7463	0.6667	0.6329	0.5952	0.4902	0.3650	0.2941
484	8TH	OF	8	SOLIDS	2/ 5/14/ 0/5/0	CLEAR	1.0638	0.9434	0.7463	0.6410	0.6173	0.5495	0.4464	0.3333	0.2381
765	1ST	UF	4	SOLIDS	1/ 7/ 8/ 1/2/0	CLEAR	0.0000	0.0000	0.0000	0.0000	0.0000	0.0000	0.0000	0.0000	0.0000
765	2ND	OF	4	SOLIDS	2/11/14/ 4/3/3	CLEAR	0.0000	0.0000	0.0000	0.0000	0.0000	0.0000	0.0000	0.0000	0.0000
765	3RD	UF	4	SOLIDS	2/13/14/ 0/5/0	CLEAR	0.0000	0.0000	0.0000	0.0000	0.0000	0.0000	0.0000	0.0000	0.0000
765	4TH	UF	4	SOLIDS	2/ 7/14/ 0/5/0	CLEAR	0.0000	0.0000	0.0000	0.0000	0.0000	0.0000	0.0000	0.0000	0.0000
765	5TH	UF	4	SOLIDS	2/ 7/14/ 0/5/0	CLEAR	0.0000	0.0000	0.0000	0.0000	0.0000	0.0000	0.0000	0.0000	0.0000
765	6TH	OF	4	SOLIDS	2/ 9/14/ 0/5/0	CLEAR	0.0000	0.0000	0.0000	0.0000	0.0000	0.0000	0.0000	0.0000	0.0000
765	7TH	UF	4	SOLIDS	2/ 9/14/ 0/5/0	CLEAR	0.0000	0.0000	0.0000	0.0000	0.0000	0.0000	0.0000	0.0000	0.0000
765	8TH	UF	4	SOLIDS	6/ 0/ 0/ 0/0/0	CLEAR	0.9615	0.9615	0.8333	0.6250	0.5556	0.3846	0.0602	0.0000	0.0000
765	9TH	OF	4	SOLIDS	6/ 0/ 0/ 0/0/0	10.280	0.8772	0.9091	0.7692	0.5495	0.5155	0.2924	0.0579	0.0000	0.0000

COMPUTER CHECK NO. 2500

A3 - 4 Comp. Check No. 2600, Female Branch-Line Installation (W.C.2), Gradient 1:200.

GREENWICH DISTRICT HOSPITAL, ON SITE
 MONITORING OF ABOVE GROUND DRAINAGE.
 DR. J. A. SWAFFIELD AND MR. S. D. BUKOR.
 DRAINAGE RESEARCH GROUP, DEPARTMENT OF
 BUILDING TECHNOLOGY BRUNEL UNIVERSITY.

ORANGE W.C. GRADIENT = 1:200.
 FEMALE SUITE OF W.C. S.

NUMBER OF RUNS UNDER COMPARISON = 630 .

VELOCITY MEASURING POINT.
 DISTANCE (M) FROM W.C.
 SENSOR SEPARATION (M) :

1	2	3	4	5	6	7	8	9
3.570	4.570	5.570	6.570	7.570	8.570	9.570	10.570	11.570
1.0	1.0	1.0	1.0	1.0	1.0	1.0	1.0	1.0

RUN NO. RELATIVE PUSH. CLASSIFICATION STOP
 SOLID IF. FLUSH. NO. OF SOLID. POSN.

VELOCITY, M/S.

2	NO OTHER SOLID	2/ 7/14/ 0/3/0	CLEAR	0.8475	0.8197	0.8065	0.7266	0.6944	0.6250	0.5376	0.4505	0.3846
4	NO OTHER SOLID	2/ 9/15/ 0/3/0	CLEAR	0.9091	0.8929	0.7937	0.7692	0.7463	0.7143	0.6410	0.6098	0.5376
17	NO OTHER SOLID	2/ 5/14/ 0/3/0	CLEAR	0.9091	0.8333	0.7692	0.7355	0.7143	0.6757	0.5814	0.5000	0.4032
19	NO OTHER SOLID	1/ 0/ 0/11/1/0	CLEAR	1.4706	1.0000	1.0417	0.9259	0.7576	0.8197	0.6329	0.5814	0.6250
21	NO OTHER SOLID	2/11/15/ 0/3/0	CLEAR	0.9091	0.8333	0.7576	0.6757	0.6694	0.5747	0.4237	0.3185	0.1613
24	NO OTHER SOLID	2/ 7/15/ 0/3/0	CLEAR	0.8621	0.9091	0.7937	0.7246	0.6250	0.6410	0.5208	0.4464	0.3546
25	NO OTHER SOLID	2/13/15/ 0/3/0	CLEAR	0.8065	0.7813	0.6757	0.5952	0.4386	0.2674	0.0998	0.0789	0.0755
29	NO OTHER SOLID	2/ 7/15/ 0/3/0	CLEAR	0.8772	0.8333	0.7576	0.6667	0.6494	0.5618	0.4630	0.4000	0.3049
31	NO OTHER SOLID	2/15/14/ 0/3/0	CLEAR	0.8333	0.8333	0.7692	0.6667	0.5618	0.4464	0.2994	0.2347	0.2304
32	NO OTHER SOLID	2/ 9/14/ 0/3/0	CLEAR	0.8929	0.8621	0.7576	0.6757	0.6757	0.5814	0.4348	0.3145	0.2618
41	NO OTHER SOLID	2/ 9/15/ 0/3/0	CLEAR	0.9434	0.9259	0.7937	0.7353	0.6757	0.6849	0.6494	0.6250	0.5435
44	NO OTHER SOLID	2/12/15/ 0/3/0	CLEAR	0.8333	0.8065	0.7246	0.6849	0.6494	0.5051	0.3937	0.3030	0.2551
50	NO OTHER SOLID	2/ 9/15/ 0/3/0	10.020	0.9434	0.9259	0.7463	0.6410	0.4464	0.3650	0.0000	0.0000	0.0000
55	NO OTHER SOLID	2/ 7/16/ 0/3/0	CLEAR	0.8621	0.8929	0.8065	0.7246	0.6849	0.5952	0.5814	0.4762	0.3817
58	NO OTHER SOLID	2/ 7/14/ 0/3/0	CLEAR	0.8065	0.8475	0.7353	0.6410	0.6024	0.4505	0.3378	0.1873	0.1515
60	NO OTHER SOLID	2/ 7/14/ 0/3/0	CLEAR	0.8772	0.8197	0.7353	0.7062	0.6579	0.6410	0.5376	0.4464	0.3546
65	NO OTHER SOLID	2/ 7/14/ 0/3/0	CLEAR	1.0417	0.9091	0.7937	0.7463	0.7266	0.6757	0.6579	0.5747	0.4762
65	NO OTHER SOLID	2/ 7/14/ 0/3/0	CLEAR	0.8929	0.8929	0.7813	0.6579	0.6694	0.5814	0.4808	0.3571	0.2717
72	NO OTHER SOLID	2/13/15/ 0/3/0	7.050	0.6494	0.6849	0.5618	0.0000	0.0000	0.0000	0.0000	0.0000	0.0000
75	NO OTHER SOLID	2/15/15/ 0/3/0	CLEAR	0.0000	0.0000	0.0000	0.0000	0.0000	0.6173	0.6410	0.5814	0.5102
74	NO OTHER SOLID	2/ 7/14/ 0/3/0	CLEAR	0.9091	0.8475	0.7246	0.7246	0.6757	0.6173	0.5102	0.2976	0.1502

83	NO OTHER SOLID	2/ 5/15/ 0/3/0	CLEAR	0.8621	0.8197	0.7353	0.6667	0.5814	0.5102	0.4202	0.2890	0.2874
85	NO OTHER SOLID	2/11/15/ 0/3/0	CLEAR	0.8197	0.8475	0.7692	0.7163	0.6667	0.5495	0.4386	0.3182	0.2513
93	NO OTHER SOLID	2/12/15/ 0/3/0	CLEAR	0.8197	0.8197	0.7042	0.5682	0.4854	0.3425	0.1404	0.0877	0.0789
101	NO OTHER SOLID	2/ 4/14/ 0/3/0	CLEAR	0.9259	0.8621	0.8929	0.7813	0.7937	0.7463	0.7042	0.6757	0.5747
106	NO OTHER SOLID	2/ 5/14/ 0/3/0	CLEAR	0.8475	0.7353	0.7042	0.6494	0.5882	0.4854	0.4098	0.3448	0.2762
107	NO OTHER SOLID	2/ 7/14/ 0/3/0	CLEAR	0.8621	0.8197	0.7576	0.6579	0.5952	0.4950	0.3906	0.2994	0.2326
108	NO OTHER SOLID	2/11/14/ 0/3/0	CLEAR	0.8197	0.8475	0.8065	0.6849	0.6579	0.5556	0.4464	0.3401	0.2762
110	NO OTHER SOLID	2/ 7/14/ 0/3/0	CLEAR	0.9434	0.8333	0.7813	0.7163	0.7042	0.6494	0.5376	0.4464	0.3378
112	NO OTHER SOLID	2/ 9/14/ 0/3/0	CLEAR	0.8333	0.8065	0.6667	0.5618	0.4673	0.3333	0.2183	0.1969	0.1553
116	NO OTHER SOLID	2/ 9/15/ 0/3/0	CLEAR	0.9259	0.8772	0.7692	0.7463	0.7246	0.6494	0.4950	0.2488	0.1603
118	NO OTHER SOLID	2/13/15/ 0/3/0	CLEAR	0.9091	0.9091	0.8475	0.7813	0.7246	0.7042	0.6494	0.5952	0.4762
120	NO OTHER SOLID	2/12/14/ 0/3/0	CLEAR	0.8197	0.8621	0.8065	0.7353	0.6667	0.5814	0.4545	0.3448	0.2717
123	NO OTHER SOLID	2/ 7/14/ 0/3/0	CLEAR	0.9615	0.9434	0.8475	0.7353	0.7692	0.6944	0.6410	0.5882	0.4808
127	NO OTHER SOLID	2/11/14/ 0/3/0	CLEAR	0.9259	0.8621	0.7813	0.7042	0.6494	0.6494	0.4854	0.4132	0.3268
132	NO OTHER SOLID	2/ 9/14/ 0/3/0	CLEAR	1.5625	0.8929	0.7813	0.6944	0.6667	0.6494	0.5618	0.4587	0.3546
137	NO OTHER SOLID	2/ 7/15/ 0/3/0	CLEAR	0.8197	0.8333	0.7813	0.7163	0.6410	0.5618	0.4505	0.3289	0.2392
138	NO OTHER SOLID	2/12/16/30/3/5	6.020	0.7813	0.8410	0.0000	0.0000	0.0000	0.0000	0.0000	0.0000	0.0000
144	NO OTHER SOLID	2/ 7/14/24/3/3	2.550	0.9259	0.8772	0.7143	0.6410	0.5435	0.5051	0.3106	0.1238	0.0613
148	NO OTHER SOLID	2/11/14/ 0/3/0	CLEAR	1.5625	0.9615	0.8475	0.7246	0.7813	0.7576	0.6849	0.6329	0.5102
149	NO OTHER SOLID	2/ 7/14/ 0/3/0	10.770	0.8929	0.9091	0.7246	0.6757	0.6098	0.5208	0.4202	0.0000	0.0000
152	NO OTHER SOLID	2/ 5/14/ 0/3/0	CLEAR	0.8065	0.8475	0.7353	0.6849	0.6757	0.5952	0.4854	0.4425	0.3704
160	NO OTHER SOLID	2/11/14/ 0/3/0	CLEAR	0.8621	0.8621	0.7163	0.6579	0.6494	0.6173	0.5155	0.4310	0.4000
165	NO OTHER SOLID	2/11/14/ 0/3/0	CLEAR	0.8929	0.8475	0.7042	0.6579	0.6410	0.5747	0.4505	0.3311	0.2703
164	NO OTHER SOLID	2/13/14/ 0/3/0	CLEAR	0.8065	0.8065	0.6849	0.6250	0.5882	0.5155	0.3906	0.2538	0.2439
166	NO OTHER SOLID	2/ 7/14/30/3/5	11.670	0.0000	0.0000	0.0000	0.0000	0.0000	0.0000	0.2747	0.2404	0.0000
167	NO OTHER SOLID	2/ 7/14/30/3/5	CLEAR	0.0000	0.0000	0.0000	0.0000	0.0000	0.0000	0.0000	0.0000	0.0000
168	NO OTHER SOLID	2/ 5/14/ 0/3/0	CLEAR	0.9259	0.8929	0.7813	0.7576	0.7246	0.6849	0.6410	0.5556	0.5000
172	NO OTHER SOLID	2/11/15/ 0/3/0	CLEAR	0.9615	0.9434	0.7692	0.6944	0.6849	0.6579	0.6024	0.5376	0.4717
175	NO OTHER SOLID	2/ 5/15/ 0/3/0	CLEAR	1.0870	1.0204	0.8929	0.7937	0.7576	0.7353	0.7042	0.6494	0.5952
176	NO OTHER SOLID	2/11/14/ 0/3/0	CLEAR	0.9259	0.9434	0.8333	0.7692	0.7576	0.6944	0.6579	0.6098	0.5618
183	NO OTHER SOLID	2/11/14/ 0/3/0	CLEAR	0.8475	0.7937	0.6410	0.4425	0.2907	0.1639	0.1348	0.1416	0.1229
187	NO OTHER SOLID	2/ 5/12/ 0/3/0	CLEAR	1.0417	0.9434	0.7813	0.7692	0.7246	0.6944	0.6667	0.6410	0.5952
188	NO OTHER SOLID	2/ 5/14/ 0/3/0	CLEAR	1.1364	0.9434	0.9091	0.8065	0.7937	0.7813	0.6757	0.6410	0.5435

190	NO OTHER SOLID	2/ 5/15/ 0/5/0	CLEAR	0.8475	0.8621	0.7692	0.7143	0.6849	0.6329	0.5435	0.4902	0.4032
194	NO OTHER SOLID	2/ 6/14/ 0/5/0	CLEAR	0.8621	0.8333	0.6667	0.6329	0.6098	0.5556	0.4673	0.3817	0.3012
195	NO OTHER SOLID	2/ 5/14/ 0/5/0	CLEAR	1.0870	0.9091	0.8475	0.8333	0.9091	0.7042	0.6579	0.6757	0.6579
196	NO OTHER SOLID	2/12/14/ 0/5/0	CLEAR	0.8197	0.8065	0.7143	0.5882	0.5051	0.3846	0.2049	0.1812	0.1613
201	NO OTHER SOLID	2/13/14/ 0/5/0	CLEAR	0.9091	0.9259	0.8197	0.7463	0.7353	0.7246	0.5952	0.5155	0.4808
202	NO OTHER SOLID	2/ 9/14/ 0/5/0	CLEAR	1.0000	0.9615	0.8772	0.7813	0.7937	0.7246	0.7353	0.6579	0.5618
217	NO OTHER SOLID	2/ 7/14/ 0/5/0	CLEAR	0.9259	0.9804	0.8065	0.7042	0.7143	0.7143	0.6410	0.5814	0.4902
222	NO OTHER SOLID	2/13/14/ 0/5/0	CLEAR	0.8475	0.9615	0.8065	0.6944	0.7143	0.6494	0.5376	0.4348	0.3425
232	NO OTHER SOLID	2/ 9/15/ 0/5/0	CLEAR	0.8772	0.8929	0.7937	0.6849	0.6250	0.6329	0.5051	0.3937	0.2591
235	NO OTHER SOLID	2/ 9/14/ 0/5/0	CLEAR	0.8621	0.8333	0.7692	0.6944	0.6579	0.6329	0.5155	0.3876	0.2857
235	NO OTHER SOLID	2/11/14/ 0/5/0	CLEAR	0.7937	0.7937	0.7353	0.6250	0.5319	0.3846	0.2564	0.2016	0.1601
240	NO OTHER SOLID	2/ 9/14/ 0/5/0	CLEAR	0.9259	0.8475	0.7937	0.7463	0.7353	0.6579	0.5952	0.5319	0.3676
242	NO OTHER SOLID	2/ 4/15/ 0/5/0	10.770	0.8621	0.8772	0.7692	0.7042	0.6579	0.6024	0.5000	0.0000	0.0000
246	NO OTHER SOLID	2/ 9/14/ 0/5/0	CLEAR	1.0417	1.0417	0.8333	0.6667	0.6410	0.6410	0.6250	0.5435	0.4673
255	NO OTHER SOLID	2/ 9/14/ 0/5/0	CLEAR	0.8621	0.8621	0.8475	0.7042	0.6757	0.5747	0.5556	0.4950	0.3937
265	NO OTHER SOLID	2/12/15/ 0/5/0	CLEAR	0.8333	0.8065	0.7143	0.5952	0.5208	0.4032	0.2551	0.1845	0.1618
267	NO OTHER SOLID	2/11/15/ 0/5/0	CLEAR	1.0204	1.0000	0.9091	0.8065	0.7692	0.6579	0.6849	0.6098	0.5952
271	NO OTHER SOLID	2/ 9/15/ 0/5/0	CLEAR	0.8333	0.7937	0.6410	0.5376	0.4237	0.3030	0.2137	0.1805	0.1724
275	NO OTHER SOLID	2/ 7/14/ 0/5/0	CLEAR	1.0417	1.0204	0.8333	0.7937	0.7692	0.6667	0.7042	0.6098	0.5556
277	NO OTHER SOLID	2/ 7/14/ 0/5/0	CLEAR	0.8929	0.8772	0.8333	0.6579	0.6757	0.7143	0.5952	0.4950	0.4310
282	NO OTHER SOLID	2/12/15/ 0/5/0	CLEAR	0.9259	0.8772	0.7813	0.7463	0.7246	0.6250	0.5747	0.4167	0.3145
283	NO OTHER SOLID	2/ 7/14/ 0/5/0	CLEAR	0.8621	0.8772	0.8197	0.7463	0.6849	0.6173	0.5208	0.4386	0.3623
289	NO OTHER SOLID	2/ 9/15/ 0/5/0	CLEAR	0.8621	0.9434	0.8197	0.7463	0.6250	0.5814	0.5376	0.4545	0.2451
298	NO OTHER SOLID	2/ 7/14/ 0/5/0	CLEAR	0.9091	0.9434	0.7463	0.6944	0.7042	0.6329	0.5682	0.4762	0.4032
302	NO OTHER SOLID	2/ 9/13/ 0/5/0	CLEAR	0.9434	0.9091	0.8065	0.7692	0.6849	0.6849	0.6849	0.6098	0.5263
305	NO OTHER SOLID	2/11/14/ 0/5/0	CLEAR	0.8929	0.8929	0.8065	0.6849	0.6610	0.6098	0.5376	0.4237	0.3106
305	NO OTHER SOLID	2/ 9/14/ 0/5/0	CLEAR	0.8621	0.8333	0.7143	0.6329	0.6024	0.5435	0.5000	0.4000	0.3185
314	NO OTHER SOLID	2/ 9/12/ 0/5/0	CLEAR	0.8772	0.9804	0.7692	0.7692	0.7576	0.6667	0.5882	0.5556	0.4464
320	NO OTHER SOLID	2/ 7/15/ 0/5/0	CLEAR	0.8929	0.8621	0.7937	0.7576	0.7246	0.6667	0.6329	0.5556	0.4808
321	NO OTHER SOLID	2/ 9/14/ 0/5/0	CLEAR	0.9434	0.9091	0.8065	0.7246	0.6849	0.6494	0.5952	0.4587	0.3788
323	NO OTHER SOLID	2/ 7/13/ 0/5/0	CLEAR	0.9091	0.8929	0.7937	0.7576	0.7143	0.6757	0.5882	0.4950	0.4425
324	NO OTHER SOLID	2/ 9/14/ 0/5/0	CLEAR	0.7692	0.7937	0.7246	0.6024	0.4032	0.2358	0.1147	0.1099	0.1259
326	NO OTHER SOLID	2/11/14/ 0/5/0	11.020	0.7692	0.7576	0.6757	0.5495	0.3846	0.2058	0.0846	0.0000	0.0000

329	NO OTHER SOLID	2/ 7/11/14/ 0/3/0	CLEAR	0.9259	0.8929	0.6197	0.7355	0.7042	0.6173	0.5618	0.4237	0.5448
333	NO OTHER SOLID	2/ 7/11/14/ 0/3/0	CLEAR	0.8772	0.8772	0.7937	0.7463	0.6849	0.6329	0.5747	0.5051	0.4065
334	NO OTHER SOLID	2/ 5/16/ 0/3/0	CLEAR	0.9259	0.9091	0.7576	0.7576	0.7143	0.6173	0.5208	0.4630	0.4274
338	NO OTHER SOLID	2/11/11/0/ 0/3/0	CLEAR	0.8929	0.8475	0.7143	0.5319	0.3817	0.1761	0.1211	0.1323	0.1397
340	NO OTHER SOLID	2/ 5/11/14/ 0/3/0	CLEAR	0.8333	0.8929	0.7492	0.7143	0.6757	0.5882	0.5155	0.3788	0.2463
341	NO OTHER SOLID	2/11/11/14/ 0/3/0	7.270	0.7246	0.7692	0.6024	0.3067	0.0000	0.0000	0.0000	0.0000	0.0000
346	NO OTHER SOLID	2/ 7/11/14/ 0/3/0	CLEAR	1.0000	0.9804	0.8621	0.7463	0.7143	0.7463	0.7143	0.6329	0.5814
347	NO OTHER SOLID	2/ 5/11/14/ 0/3/0	CLEAR	1.0638	0.9434	0.8772	0.7353	0.7353	0.7353	0.7143	0.6667	0.6250
348	NO OTHER SOLID	2/ 7/11/15/ 0/3/0	CLEAR	0.9091	0.9615	0.8621	0.7576	0.7246	0.7143	0.6494	0.5882	0.5319
350	NO OTHER SOLID	2/ 7/11/15/ 0/3/0	12.270	0.7813	0.8621	0.6849	0.6579	0.4673	0.2092	0.0836	0.0735	0.0506
354	NO OTHER SOLID	2/ 7/11/14/ 0/3/0	CLEAR	0.8621	1.0204	0.6197	0.7463	0.6944	0.6173	0.6098	0.5051	0.4237
365	NO OTHER SOLID	2/ 5/11/15/ 0/3/0	CLEAR	0.7246	0.6410	0.4202	0.3247	0.2890	0.3030	0.2924	0.2825	0.2674
372	NO OTHER SOLID	2/11/11/15/ 0/3/0	CLEAR	0.8621	0.8772	0.6944	0.7143	0.6579	0.6173	0.5882	0.5051	0.4310
376	NO OTHER SOLID	2/ 7/11/14/ 0/3/0	CLEAR	1.0638	0.9259	0.8065	0.7463	0.7463	0.6494	0.6250	0.6098	0.5102
378	NO OTHER SOLID	2/11/11/16/ 0/3/0	CLEAR	0.9091	0.8772	0.7143	0.7042	0.6944	0.6849	0.6757	0.5814	0.5000
390	NO OTHER SOLID	2/11/11/16/ 0/3/0	CLEAR	0.9615	0.9804	0.8197	0.7463	0.7813	0.7576	0.7042	0.6329	0.5682
400	NO OTHER SOLID	2/ 5/11/15/ 0/3/0	CLEAR	0.9434	0.9434	0.7246	0.6667	0.7576	0.7143	0.6667	0.6098	0.5556
404	NO OTHER SOLID	2/ 5/11/16/ 0/3/0	CLEAR	1.0204	0.9259	0.8197	0.8065	0.7692	0.7246	0.6667	0.6024	0.5556
435	NO OTHER SOLID	2/11/11/15/ 0/3/0	CLEAR	0.9091	0.9434	0.7692	0.7692	0.7463	0.6579	0.6494	0.5882	0.5102
441	NO OTHER SOLID	2/ 7/11/15/ 0/3/0	CLEAR	0.8772	0.8772	0.7576	0.7353	0.7353	0.6494	0.6173	0.5435	0.4425
442	NO OTHER SOLID	2/ 9/11/14/ 0/3/0	CLEAR	0.8621	1.0638	0.8475	0.7813	0.7576	0.7576	0.6667	0.6494	0.6329
444	NO OTHER SOLID	2/11/11/15/ 0/3/0	CLEAR	0.8772	0.9615	0.6944	0.6944	0.6494	0.6494	0.5682	0.4762	0.3876
447	NO OTHER SOLID	2/ 7/11/13/ 0/3/0	CLEAR	1.1364	1.0638	0.9259	0.8475	0.8197	0.8065	0.7937	0.6849	0.6410
456	NO OTHER SOLID	2/ 9/11/14/ 0/3/0	CLEAR	1.0204	1.0000	0.8333	0.6944	0.6849	0.7143	0.7143	0.6024	0.5319
463	NO OTHER SOLID	2/ 7/11/16/ 0/3/0	CLEAR	0.9434	0.8772	0.7692	0.7246	0.6667	0.6494	0.6098	0.5155	0.4000
465	NO OTHER SOLID	2/ 9/11/14/ 0/3/0	CLEAR	0.9259	1.0000	0.8333	0.7813	0.7246	0.7143	0.6849	0.5952	0.5263
468	NO OTHER SOLID	2/ 9/11/14/ 0/3/0	CLEAR	0.9259	1.0204	0.8475	0.7813	0.7246	0.6849	0.6849	0.6250	0.5435
479	NO OTHER SOLID	2/ 9/11/14/ 0/3/0	CLEAR	0.9434	0.9615	0.7813	0.7692	0.6944	0.6849	0.6024	0.5376	0.4386
482	NO OTHER SOLID	2/12/11/13/ 0/3/0	CLEAR	0.8475	0.8197	0.7042	0.6757	0.5102	0.3906	0.2347	0.1543	0.1538
486	NO OTHER SOLID	2/ 9/11/14/ 0/3/0	CLEAR	0.8333	0.8621	0.7813	0.7246	0.6494	0.5952	0.5000	0.4202	0.3425
489	NO OTHER SOLID	2/ 7/11/14/ 0/3/0	CLEAR	1.0000	0.9804	0.7937	0.7692	0.7246	0.7353	0.7246	0.6494	0.5376
491	NO OTHER SOLID	2/ 7/11/14/ 0/3/0	CLEAR	0.8065	0.8475	0.7246	0.6667	0.5882	0.4762	0.3759	0.2994	0.2415
497	NO OTHER SOLID	2/ 9/11/14/ 0/3/0	CLEAR	0.8065	0.8065	0.7576	0.6579	0.5882	0.5208	0.3906	0.2703	0.1976

500	NO OTHER SOLID	2/ 7/14/ 0/5/0	CLEAR	0.8065	0.8929	0.8333	0.7463	0.6757	0.6410	0.6173	0.4762	0.3704
504	NO OTHER SOLID	2/ 7/14/ 0/5/0	9.870	0.7143	0.8475	0.5882	0.4808	0.2525	0.0982	0.0000	0.0000	0.0000
509	NO OTHER SOLID	2/ 7/14/ 0/5/0	CLEAR	0.8929	0.8621	0.7937	0.7143	0.6494	0.5882	0.5952	0.4854	0.4098
511	NO OTHER SOLID	2/ 7/14/ 0/5/0	CLEAR	0.8333	0.9259	0.7813	0.7143	0.6667	0.6494	0.5682	0.4505	0.3623
514	NO OTHER SOLID	2/11/14/ 0/5/0	CLEAR	0.8621	0.9615	0.7813	0.7353	0.7042	0.6410	0.5814	0.5000	0.4032
521	NO OTHER SOLID	2/ 7/14/ 0/5/0	CLEAR	0.9091	0.8772	0.7353	0.7042	0.6410	0.5814	0.4762	0.3759	0.2273
526	NO OTHER SOLID	2/ 7/15/ 0/5/0	CLEAR	1.0000	0.8475	0.7353	0.6944	0.5618	0.5051	0.4310	0.3788	0.3185
529	NO OTHER SOLID	2/ 9/14/ 0/5/0	10.370	0.8475	0.8475	0.6944	0.6579	0.5208	0.3578	0.0648	0.0000	0.0000
532	NO OTHER SOLID	2/ 7/14/ 0/5/0	CLEAR	0.9615	0.9259	0.7042	0.6757	0.6667	0.5952	0.5618	0.4902	0.3817
536	NO OTHER SOLID	2/ 5/14/ 0/5/0	CLEAR	0.9804	0.9434	0.8333	0.7576	0.7576	0.7463	0.6757	0.5682	0.5618
538	NO OTHER SOLID	2/ 7/14/ 0/5/0	CLEAR	0.9434	0.9615	0.8621	0.7463	0.7042	0.6849	0.6494	0.6173	0.5319
539	NO OTHER SOLID	2/10/14/ 0/5/0	6.420	0.6849	0.6694	0.4348	0.0000	0.0000	0.0000	0.0000	0.0000	0.0000
541	NO OTHER SOLID	2/ 9/14/ 0/5/0	CLEAR	0.8929	0.9091	0.8197	0.7463	0.7143	0.6494	0.6579	0.5376	0.4650
542	NO OTHER SOLID	2/ 5/14/ 0/5/0	CLEAR	0.8475	0.9259	0.7813	0.7576	0.6757	0.6329	0.6250	0.5747	0.4950
547	NO OTHER SOLID	2/15/14/ 0/5/0	CLEAR	0.8333	0.8621	0.7576	0.6494	0.5695	0.3521	0.1712	0.1323	0.1082
555	NO OTHER SOLID	2/15/15/ 0/5/0	CLEAR	0.8621	0.9259	0.7042	0.6494	0.6024	0.5051	0.4000	0.3012	0.2959
560	NO OTHER SOLID	2/15/14/ 0/5/0	12.170	0.7937	0.8065	0.6667	0.5376	0.3906	0.1976	0.0690	0.0600	0.0501
564	NO OTHER SOLID	2/ 7/14/ 0/5/0	CLEAR	0.9434	0.9091	0.7813	0.7353	0.7353	0.6410	0.6250	0.5435	0.4587
566	NO OTHER SOLID	2/ 7/10/ 0/5/0	CLEAR	0.8621	0.8475	0.7576	0.6579	0.5952	0.5556	0.3817	0.2381	0.1767
567	NO OTHER SOLID	2/ 7/14/ 0/5/0	CLEAR	0.8621	0.8621	0.6849	0.6410	0.6024	0.4587	0.3425	0.2513	0.1838
576	NO OTHER SOLID	2/ 9/14/ 0/5/0	CLEAR	0.8929	0.8772	0.7813	0.7246	0.6667	0.6410	0.6024	0.4854	0.3676
579	NO OTHER SOLID	2/11/14/ 0/5/0	CLEAR	0.9091	0.9091	0.7353	0.7042	0.6173	0.5495	0.4673	0.3401	0.1894
583	NO OTHER SOLID	2/ 5/14/ 0/5/0	CLEAR	0.9259	0.9259	0.8065	0.7246	0.7143	0.6250	0.6579	0.5682	0.4762
589	NO OTHER SOLID	2/ 9/14/ 0/5/0	12.170	0.8197	0.8197	0.7042	0.5814	0.4950	0.2762	0.1351	0.1073	0.0457
591	NO OTHER SOLID	2/ 7/14/ 0/5/0	CLEAR	0.8621	0.9434	0.7813	0.7353	0.6849	0.6173	0.6098	0.5102	0.4630
592	NO OTHER SOLID	2/ 7/14/ 0/5/0	CLEAR	0.9091	0.9434	0.7692	0.7246	0.6944	0.6494	0.6494	0.5618	0.4545
593	NO OTHER SOLID	2/ 9/14/ 0/5/0	CLEAR	0.8065	0.8621	0.6944	0.6098	0.5376	0.4348	0.3067	0.2304	0.3012
595	NO OTHER SOLID	2/ 5/14/ 0/5/0	CLEAR	0.8333	0.9434	0.8197	0.7692	0.7353	0.6849	0.6329	0.5682	0.5102
597	NO OTHER SOLID	2/12/14/ 0/5/0	CLEAR	0.8929	0.8772	0.6944	0.7143	0.7143	0.5814	0.5495	0.4310	0.3145
602	NO OTHER SOLID	6/ 5/15/ 0/5/0	CLEAR	0.8197	1.0000	0.6579	0.5952	0.5319	0.4065	0.3030	0.2073	0.1773
603	NO OTHER SOLID	2/ 5/15/ 0/5/0	CLEAR	0.7692	0.7813	0.6757	0.5814	0.4673	0.3086	0.1976	0.1961	0.1497
607	NO OTHER SOLID	2/ 5/14/ 0/5/0	CLEAR	0.8475	0.9434	0.8333	0.7576	0.7042	0.6667	0.5952	0.4762	0.3497
617	NO OTHER SOLID	7/10/14/ 0/5/0	CLEAR	0.8197	0.9434	0.7576	0.7143	0.6410	0.5618	0.4425	0.3521	0.2890

620	NO OTHER SOLID	2/11/14/	0/3/0	10.740	0.7163	0.8197	0.7042	0.6098	0.4630	0.2857	0.1887	0.0000	0.0000
621	NO OTHER SOLID	2/ 7/15/	0/3/0	CLEAR	0.9091	0.8929	0.8333	0.7246	0.6849	0.6173	0.5814	0.5263	0.4386
631	NO OTHER SOLID	2/ 7/14/	0/3/0	CLEAR	0.8475	0.8475	0.7692	0.6757	0.6667	0.6173	0.5208	0.4425	0.3676
667	NO OTHER SOLID	2/13/14/	0/3/0	11.740	0.7692	0.8475	0.7042	0.5319	0.3906	0.2155	0.1961	0.1256	0.0000
670	NO OTHER SOLID	2/ 9/14/	0/3/0	6.170	0.5618	0.4386	0.1742	0.0000	0.0000	0.0000	0.0000	0.0000	0.0000
685	NO OTHER SOLID	2/11/14/	0/3/0	CLEAR	0.8065	0.9091	0.7246	0.6329	0.6579	0.6024	0.5519	0.4673	0.3817
687	NO OTHER SOLID	2/14/15/	0/3/0	6.770	0.6579	0.7353	0.5682	0.0000	0.0000	0.0000	0.0000	0.0000	0.0000
690	NO OTHER SOLID	2/ 5/15/	0/3/0	CLEAR	0.8929	0.9615	0.8333	0.6667	0.6849	0.6667	0.6173	0.5556	0.4950
692	NO OTHER SOLID	2/ 7/15/	0/3/0	CLEAR	0.8333	0.8621	0.6329	0.5319	0.4587	0.3030	0.2155	0.2439	0.1852
695	NO OTHER SOLID	2/ 5/16/	0/3/0	CLEAR	0.9804	0.9434	0.7042	0.7353	0.7246	0.6757	0.6757	0.6410	0.5319
705	NO OTHER SOLID	2/ 7/15/	0/3/0	CLEAR	0.9434	0.9615	0.7463	0.7463	0.7246	0.6329	0.6173	0.5263	0.3650
706	NO OTHER SOLID	2/ 4/16/	0/3/0	CLEAR	0.9434	1.0000	0.7937	0.8197	0.7353	0.6849	0.7042	0.6667	0.5556
709	NO OTHER SOLID	2/ 9/14/	0/3/0	CLEAR	0.7692	0.8772	0.7353	0.6494	0.5556	0.4386	0.0943	0.2049	0.2273
711	NO OTHER SOLID	2/ 7/15/	0/3/0	CLEAR	0.7463	0.9259	0.6667	0.5376	0.4132	0.2778	0.1724	0.1587	0.1285
712	NO OTHER SOLID	2/11/15/	0/3/0	CLEAR	0.9091	0.9259	0.7463	0.6667	0.6579	0.5435	0.5051	0.4132	0.3448
721	NO OTHER SOLID	2/ 5/14/	0/3/0	CLEAR	0.9615	1.0000	0.8475	0.7576	0.7463	0.7042	0.6757	0.5814	0.4630
732	NO OTHER SOLID	2/ 6/14/	0/3/0	CLEAR	0.9091	0.8065	0.7143	0.7143	0.6579	0.6173	0.4902	0.3906	0.2370
742	NO OTHER SOLID	2/ 7/14/	0/3/0	CLEAR	0.8929	0.9804	0.8333	0.7353	0.7576	0.7042	0.6944	0.6024	0.5376
747	NO OTHER SOLID	2/ 5/16/	0/3/0	CLEAR	1.0000	1.0000	0.8065	0.7576	0.7353	0.7353	0.7042	0.6579	0.5882
748	NO OTHER SOLID	2/ 7/14/	0/3/0	CLEAR	0.8621	0.9259	0.7692	0.6849	0.6329	0.5882	0.5155	0.4065	0.3425
749	NO OTHER SOLID	2/ 9/15/	0/3/0	12.220	0.8475	0.8929	0.7246	0.6757	0.5102	0.3425	0.2252	0.1445	0.0789
753	NO OTHER SOLID	2/ 7/14/	0/3/0	CLEAR	0.7813	0.8065	0.7143	0.6329	0.5155	0.3571	0.2273	0.1712	0.0998
754	NO OTHER SOLID	2/ 7/15/	0/3/0	CLEAR	0.9804	0.9091	0.7353	0.6757	0.6329	0.6250	0.5882	0.5319	0.4505
755	NO OTHER SOLID	2/ 7/14/	0/3/0	CLEAR	0.9091	0.9615	0.8065	0.7353	0.7143	0.6173	0.5682	0.4902	0.4202
757	NO OTHER SOLID	2/ 9/14/	0/3/0	CLEAR	0.8333	0.8929	0.7692	0.7246	0.6944	0.6098	0.4902	0.3676	0.2336
776	NO OTHER SOLID	2/ 5/15/	0/3/0	CLEAR	0.9259	0.9615	0.8772	0.7463	0.7353	0.6329	0.6944	0.6098	0.5319
777	NO OTHER SOLID	2/10/14/	0/3/0	CLEAR	0.8475	0.8065	0.7463	0.6024	0.5435	0.4425	0.2358	0.1429	0.1374
779	NO OTHER SOLID	2/ 5/14/	0/3/0	CLEAR	0.9615	0.9804	0.8621	0.6849	0.7353	0.7042	0.6944	0.6250	0.5208
782	NO OTHER SOLID	2/ 6/14/	0/3/0	CLEAR	0.8621	0.9615	0.7246	0.7042	0.6667	0.5882	0.5263	0.3906	0.3817
791	NO OTHER SOLID	2/ 7/14/	0/3/0	10.730	0.8197	0.8065	0.6579	0.6098	0.4902	0.4202	0.3378	0.0000	0.0000
796	NO OTHER SOLID	2/ 9/14/	0/3/0	CLEAR	0.8333	0.8929	0.7813	0.7246	0.6849	0.6250	0.5263	0.4464	0.3968
797	NO OTHER SOLID	2/11/14/	0/3/0	CLEAR	0.8333	0.9259	0.7937	0.7463	0.6849	0.6024	0.5495	0.4762	0.4098
800	NO OTHER SOLID	2/ 5/14/	0/3/0	CLEAR	0.8772	0.9434	0.7937	0.7143	0.6849	0.6329	0.5814	0.5155	0.4630

802	NO OTHER SOLID	2/11/14/ 0/3/0	CLEAR	0.8475	0.9091	0.7576	0.6944	0.5747	0.5000	0.3876	0.2874	0.2174
808	NO OTHER SOLID	2/ 5/14/ 0/3/0	9.290	0.8333	0.8475	0.7042	0.6250	0.5263	0.4505	0.0000	0.0000	0.0000
818	NO OTHER SOLID	2/11/14/ 0/3/0	7.850	0.7353	0.7042	0.5155	0.2101	0.0000	0.0000	0.0000	0.0000	0.0000
821	NO OTHER SOLID	2/ 7/14/ 0/3/0	CLEAR	0.8197	0.8333	0.6175	0.5618	0.3876	0.1901	0.0984	0.0958	0.0986
824	NO OTHER SOLID	2/ 7/14/ 0/3/0	CLEAR	1.0000	0.9259	0.8333	0.7813	0.7576	0.7353	0.7143	0.6098	0.5556
826	NO OTHER SOLID	2/ 9/14/ 0/3/0	CLEAR	0.8772	0.9804	0.7463	0.6944	0.6579	0.5952	0.5814	0.4950	0.4000
831	NO OTHER SOLID	2/ 9/14/ 0/3/0	CLEAR	1.0638	0.9615	0.8475	0.7937	0.7246	0.6944	0.7246	0.6329	0.6098
835	NO OTHER SOLID	2/11/16/ 0/3/0	11.910	0.0000	0.0000	0.0000	0.5495	0.5102	0.4673	0.5145	0.1558	0.0000
837	NO OTHER SOLID	2/10/14/ 0/3/0	CLEAR	0.8475	0.8475	0.7246	0.6849	0.6329	0.5618	0.5102	0.4167	0.3704
839	NO OTHER SOLID	2/10/15/ 0/3/0	CLEAR	0.7576	0.7937	0.6579	0.5682	0.4587	0.3106	0.1736	0.1553	0.1205
841	NO OTHER SOLID	2/ 7/15/ 0/3/0	CLEAR	0.9091	0.9434	0.7143	0.6944	0.7042	0.6849	0.6667	0.6173	0.5576
856	NO OTHER SOLID	2/11/14/ 0/3/0	CLEAR	0.8475	0.8772	0.7143	0.6757	0.6329	0.5618	0.5268	0.1724	0.1445
861	NO OTHER SOLID	2/ 9/16/ 0/3/0	CLEAR	0.7463	0.7937	0.6849	0.5682	0.4587	0.4000	0.3247	0.2577	0.2203
865	NO OTHER SOLID	2/ 5/14/ 0/3/0	CLEAR	1.0204	0.9804	0.7692	0.7692	0.6944	0.6757	0.6849	0.5952	0.5556
871	NO OTHER SOLID	2/ 9/14/ 0/3/0	CLEAR	1.0204	1.0870	0.8475	0.8065	0.7813	0.7042	0.6757	0.6329	0.5747
874	NO OTHER SOLID	2/11/14/ 0/3/0	CLEAR	0.7813	0.8929	0.6944	0.5814	0.5102	0.3623	0.1866	0.1661	0.1190
881	NO OTHER SOLID	2/ 9/14/ 0/3/0	CLEAR	0.7813	0.8197	0.7463	0.6410	0.4808	0.3497	0.2577	0.2203	0.1859
885	NO OTHER SOLID	2/ 9/14/21/3/3	CLEAR	0.8475	0.8333	0.7143	0.6410	0.5747	0.4717	0.3846	0.5165	0.2604
886	NO OTHER SOLID	2/ 7/13/ 0/3/0	CLEAR	0.8197	0.7246	0.5682	0.4673	0.4065	0.2841	0.2674	0.2591	0.2525
889	NO OTHER SOLID	2/ 5/13/ 0/3/0	9.820	0.8772	0.8333	0.6579	0.6250	0.5747	0.4673	0.0000	0.0000	0.0000
892	NO OTHER SOLID	2/ 7/14/ 0/3/0	7.630	0.7937	0.7353	0.5882	0.3556	0.0000	0.0000	0.0000	0.0000	0.0000
895	NO OTHER SOLID	2/ 7/14/ 0/3/0	CLEAR	0.0000	0.0000	0.0000	0.0000	0.0000	0.6667	0.6757	0.5618	0.5435
895	NO OTHER SOLID	2/ 7/15/ 0/3/0	10.720	0.8772	0.7937	0.6494	0.5435	0.4065	0.2674	0.1225	0.0000	0.0000
905	NO OTHER SOLID	2/12/14/ 0/3/0	CLEAR	0.8929	0.9259	0.8333	0.7576	0.6849	0.6329	0.6024	0.5263	0.4425
905	NO OTHER SOLID	2/ 7/15/ 0/3/0	CLEAR	0.8929	0.8929	0.7576	0.7042	0.6944	0.5952	0.5319	0.4098	0.3125
906	NO OTHER SOLID	2/ 9/14/ 0/3/0	CLEAR	0.9434	0.9615	0.7692	0.7143	0.6579	0.6098	0.6024	0.4854	0.3937
910	NO OTHER SOLID	2/ 9/14/ 0/3/0	CLEAR	0.8621	0.8929	0.6944	0.6757	0.6849	0.6329	0.6250	0.5682	0.4854
914	NO OTHER SOLID	2/ 5/15/ 0/3/0	CLEAR	0.8333	0.9091	0.7246	0.6849	0.6610	0.6024	0.5435	0.4348	0.3937
919	NO OTHER SOLID	2/13/13/ 0/3/0	CLEAR	0.8772	0.9259	0.8197	0.7143	0.6757	0.6250	0.5747	0.4425	0.3623
939	NO OTHER SOLID	2/ 7/15/ 0/3/0	12.060	0.6667	0.6098	0.3906	0.1577	0.1149	0.1085	0.1506	0.1558	0.0000
941	NO OTHER SOLID	2/11/14/ 0/3/0	CLEAR	0.7692	0.8333	0.7042	0.6173	0.5635	0.4132	0.3125	0.2232	0.1736
942	NO OTHER SOLID	2/ 9/14/ 0/3/0	11.030	0.7463	0.6944	0.5102	0.2604	0.1736	0.1412	0.1078	0.0000	0.0000
944	NO OTHER SOLID	2/13/14/ 0/3/0	CLEAR	0.8333	0.8929	0.7813	0.6757	0.6329	0.5376	0.4673	0.4000	0.3145

947	NO OTHER SOLID	2/ 7/14/ 0/3/0	CLEAR	0.8621	0.8929	0.8333	0.7813	0.7143	0.6667	0.6494	0.5682	0.4902
959	NO OTHER SOLID	2/ 9/16/ 0/3/0	CLEAR	1.0000	1.0638	0.9434	0.7937	0.7143	0.7143	0.7143	0.6250	0.5882
962	NO OTHER SOLID	2/ 7/14/ 0/3/0	CLEAR	0.9434	0.8475	0.7813	0.6944	0.6173	0.4762	0.3817	0.2874	0.2392
967	NO OTHER SOLID	2/ 5/14/ 0/3/0	CLEAR	0.8197	0.8475	0.7576	0.6410	0.6494	0.5682	0.4950	0.4425	0.3448
973	NO OTHER SOLID	2/ 7/14/ 0/3/0	CLEAR	0.8772	0.9615	0.8065	0.7576	0.6849	0.6494	0.6329	0.5556	0.4464
974	NO OTHER SOLID	2/ 5/14/ 0/3/0	CLEAR	0.9259	0.9091	0.8065	0.7576	0.7246	0.6329	0.5882	0.5265	0.4464
975	NO OTHER SOLID	2/ 9/15/ 0/3/0	CLEAR	0.9259	0.9615	0.7576	0.6849	0.6849	0.6667	0.5556	0.4854	0.3759
986	NO OTHER SOLID	2/11/14/ 0/3/0	CLEAR	0.8333	0.8621	0.7692	0.6410	0.5882	0.5102	0.3846	0.2747	0.2551
994	NO OTHER SOLID	2/ 5/15/ 0/3/0	CLEAR	0.8065	0.8197	0.7042	0.5882	0.5495	0.4464	0.3597	0.3069	0.2525
995	NO OTHER SOLID	2/ 7/14/ 0/3/0	CLEAR	0.8772	1.0000	0.8475	0.7463	0.7143	0.6410	0.6579	0.5376	0.4587
1006	NO OTHER SOLID	2/ 5/14/ 0/3/0	CLEAR	0.8065	0.8929	0.6667	0.5376	0.5155	0.4132	0.4032	0.3597	0.3268
1008	NO OTHER SOLID	2/ 5/14/ 0/3/0	CLEAR	0.8772	0.8929	0.7143	0.6579	0.6667	0.5814	0.5155	0.4274	0.3533
1011	NO OTHER SOLID	2/ 5/14/ 0/3/0	CLEAR	0.7815	0.7353	0.5495	0.5000	0.4464	0.3817	0.3333	0.3356	0.2809
1014	NO OTHER SOLID	2/ 7/15/ 0/3/0	CLEAR	0.8772	0.8333	0.7813	0.6757	0.6173	0.5263	0.4310	0.2591	0.1852
1022	NO OTHER SOLID	2/ 7/14/ 0/3/0	CLEAR	0.8333	0.8929	0.7463	0.6250	0.6098	0.5208	0.3937	0.2825	0.2232
1023	NO OTHER SOLID	2/ 7/14/ 0/3/0	CLEAR	0.7937	0.8475	0.7353	0.6757	0.6024	0.4902	0.4152	0.3378	0.2907
36	1ST OF 2 SOLIDS	2/ 4/15/ 0/3/0	CLEAR	0.9091	0.8621	0.7463	0.7353	0.7463	0.6579	0.6024	0.5376	0.4237
36	2ND OF 2 SOLIDS	2/ 7/14/ 0/3/0	CLEAR	0.9259	0.8333	0.7692	0.7042	0.6579	0.6579	0.5556	0.4630	0.4000
39	1ST OF 2 SOLIDS	2/ 7/14/ 0/3/0	CLEAR	0.9259	0.9259	0.7937	0.7143	0.7042	0.6410	0.5495	0.4854	0.3937
39	2ND OF 2 SOLIDS	2/ 5/14/ 0/3/0	CLEAR	0.6757	0.5952	0.4167	0.3030	0.2994	0.2632	0.2252	0.2066	0.1366
77	1ST OF 2 SOLIDS	2/ 9/14/ 0/3/0	CLEAR	0.8929	0.8929	0.7692	0.7143	0.7042	0.6329	0.5882	0.4950	0.3866
77	2ND OF 2 SOLIDS	2/ 7/14/ 0/3/0	CLEAR	0.8621	0.8475	0.6944	0.6329	0.5952	0.4808	0.3817	0.3378	0.2890
88	1ST OF 2 SOLIDS	2/ 5/15/ 0/3/0	CLEAR	1.0638	1.0000	0.8621	0.7937	0.8065	0.7576	0.7246	0.6944	0.6098
88	2ND OF 2 SOLIDS	2/ 5/15/ 0/3/0	CLEAR	1.0000	0.9804	0.8197	0.7576	0.7692	0.7463	0.7143	0.6579	0.5882
98	1ST OF 2 SOLIDS	2/ 4/14/ 0/3/0	CLEAR	0.9615	0.9259	0.6944	0.7353	0.7353	0.6757	0.6494	0.6329	0.5376
98	2ND OF 2 SOLIDS	2/13/15/ 0/3/0	CLEAR	0.9259	0.9091	0.7463	0.6944	0.6849	0.6250	0.5814	0.5000	0.4098
105	1ST OF 2 SOLIDS	2/ 7/15/ 0/3/0	CLEAR	1.3889	0.8772	0.7143	0.7143	0.7246	0.7042	0.6024	0.5682	0.4950
105	2ND OF 2 SOLIDS	2/ 3/16/ 0/3/0	CLEAR	0.8772	0.9091	0.7576	0.6173	0.6250	0.5618	0.5208	0.4854	0.4098
117	1ST OF 2 SOLIDS	1/ 4/ 8/ 1/1/0	CLEAR	1.0638	1.0417	0.9804	0.9434	0.8929	0.8475	0.9259	0.6329	0.6024
117	2ND OF 2 SOLIDS	2/ 7/14/ 0/3/0	CLEAR	0.8475	0.8197	0.7246	0.6494	0.6098	0.4950	0.3968	0.3623	0.2793
150	1ST OF 2 SOLIDS	2/ 7/14/ 0/3/0	CLEAR	0.0000	0.0000	0.0000	0.0000	0.0000	0.0000	0.0000	0.0000	0.5747
150	2ND OF 2 SOLIDS	2/ 7/14/ 0/3/0	CLEAR	0.8197	0.8333	0.7042	0.6250	0.5952	0.4902	0.4132	0.3521	0.2717
158	1ST OF 2 SOLIDS	2/11/15/ 0/3/0	CLEAR	0.8333	0.8772	0.7353	0.6944	0.7042	0.6329	0.5682	0.4717	0.3937
158	2ND OF 2 SOLIDS	2/ 5/15/ 0/3/0	CLEAR	0.8475	0.8621	0.7246	0.6849	0.6667	0.5882	0.5435	0.4464	0.3788
198	1ST OF 2 SOLIDS	2/ 7/14/ 0/3/0	CLEAR	0.9434	0.8929	0.8197	0.7692	0.7246	0.7042	0.6757	0.5882	0.5376
198	2ND OF 2 SOLIDS	2/ 9/14/ 0/3/0	CLEAR	0.8772	0.9091	0.8065	0.7246	0.7042	0.6250	0.5882	0.4808	0.3906
199	1ST OF 2 SOLIDS	2/11/14/ 0/3/0	CLEAR	0.9259	0.8333	0.7692	0.7246	0.7143	0.6024	0.5435	0.3597	0.1736
199	2ND OF 2 SOLIDS	2/ 9/14/ 0/3/0	CLEAR	0.8333	0.8197	0.6757	0.6098	0.5263	0.4065	0.3125	0.2793	0.2242

203	1ST OF 2 SOLIDS	2/ 5/13/ 0/3/0	CLEAR	0.9091	0.8475	0.7353	0.6869	0.6496	0.5952	0.5155	0.4274	0.3333
203	2ND OF 2 SOLIDS	2/ 7/15/ 0/3/0	CLEAR	0.8621	0.8333	0.6944	0.6869	0.6329	0.5747	0.4762	0.3906	0.2924
243	1ST OF 2 SOLIDS	2/ 4/13/ 0/3/0	CLEAR	0.0000	0.0000	0.0000	0.0000	0.0000	0.0000	0.0000	0.0000	0.5102
243	2ND OF 2 SOLIDS	2/12/14/ 0/3/0	CLEAR	0.8772	0.8929	0.8333	0.7353	0.7266	0.6667	0.5208	0.4673	0.4000
270	1ST OF 2 SOLIDS	2/ 7/14/ 0/3/0	CLEAR	1.1364	0.9259	0.7692	0.7143	0.7266	0.6757	0.6579	0.5682	0.4950
270	2ND OF 2 SOLIDS	2/ 7/14/ 0/3/0	CLEAR	0.8475	0.9091	0.8197	0.7042	0.7463	0.6250	0.6098	0.5155	0.4202
293	1ST OF 2 SOLIDS	1/ 6/ 6/ 1/2/0	CLEAR	0.0000	0.0000	0.0000	0.0000	0.0000	0.0000	0.0000	0.5493	0.5155
293	2ND OF 2 SOLIDS	2/11/14/ 0/3/0	CLEAR	0.0000	0.0000	0.0000	0.0000	0.0000	0.0000	0.0000	0.5682	0.5051
360	1ST OF 2 SOLIDS	2/ 4/13/ 0/3/0	CLEAR	0.8475	0.9615	0.7937	0.7353	0.7042	0.6494	0.5952	0.5263	0.4386
360	2ND OF 2 SOLIDS	2/11/15/ 0/3/0	CLEAR	0.7937	0.8475	0.6944	0.6494	0.5814	0.4902	0.3937	0.2874	0.2242
431	1ST OF 2 SOLIDS	2/ 5/14/ 0/3/0	CLEAR	1.1111	1.0638	0.8929	0.8065	0.7893	0.6849	0.7143	0.6944	0.6410
431	2ND OF 2 SOLIDS	2/ 5/14/ 0/3/0	CLEAR	1.0417	1.0204	0.8475	0.7692	0.7266	0.7266	0.6944	0.6667	0.5882
472	1ST OF 2 SOLIDS	4/ 0/ 0/32/0/0	CLEAR	1.0417	0.7463	0.7937	0.7143	0.6667	0.5618	0.4587	0.3817	0.2778
472	2ND OF 2 SOLIDS	6/ 0/ 0/ 0/0/0	CLEAR	1.0204	0.7576	0.7266	0.6329	0.5882	0.4854	0.4274	0.3788	0.3185
480	1ST OF 2 SOLIDS	2/ 5/16/ 0/3/0	CLEAR	0.9259	0.7692	0.7492	0.7692	0.7246	0.7143	0.6024	0.4167	0.3521
480	2ND OF 2 SOLIDS	2/11/14/ 0/3/0	5.650	0.4717	0.2404	0.0000	0.0000	0.0000	0.0000	0.0000	0.0000	0.0000
485	1ST OF 2 SOLIDS	2/ 5/14/ 0/3/0	CLEAR	0.8333	0.8197	0.7937	0.7893	0.7353	0.6024	0.5000	0.4348	0.3448
485	2ND OF 2 SOLIDS	2/12/14/ 0/3/0	CLEAR	0.7937	0.9091	0.8065	0.7576	0.6944	0.5882	0.5319	0.4237	0.3597
487	1ST OF 2 SOLIDS	2/ 9/13/ 0/3/0	CLEAR	0.8333	0.9434	0.8621	0.7937	0.7463	0.6757	0.7042	0.6250	0.5495
487	2ND OF 2 SOLIDS	2/ 9/13/ 0/3/0	CLEAR	0.8475	0.9091	0.7893	0.6869	0.6579	0.5747	0.5519	0.3425	0.3566
505	1ST OF 2 SOLIDS	2/ 7/14/ 0/3/0	12.270	0.0000	0.0000	0.0000	0.0000	0.0000	0.0000	0.0000	0.3268	0.1044
505	2ND OF 2 SOLIDS	2/ 9/14/ 0/3/0	12.120	0.8197	0.6929	0.7937	0.6410	0.6098	0.4854	0.2415	0.1786	0.0926
516	1ST OF 2 SOLIDS	1/ 2/ 4/ 1/2/0	CLEAR	1.0204	0.9804	0.8475	0.8065	0.7937	0.7813	0.8197	0.7353	0.5556
516	2ND OF 2 SOLIDS	2/ 7/14/ 0/3/0	CLEAR	0.7937	0.8621	0.7692	0.6579	0.5495	0.4237	0.2841	0.2577	0.2273
533	1ST OF 2 SOLIDS	2/ 7/14/ 0/3/0	10.670	0.8621	0.8475	0.7042	0.6410	0.5882	0.4425	0.2538	0.0000	0.0000
533	2ND OF 2 SOLIDS	2/ 7/14/ 0/3/0	7.270	0.7042	0.7576	0.5495	0.5648	0.0000	0.0000	0.0000	0.0000	0.0000
540	1ST OF 2 SOLIDS	2/16/14/ 0/3/0	CLEAR	0.0000	0.0000	0.0000	0.0000	0.6250	0.6579	0.6250	0.5208	0.4464
540	2ND OF 2 SOLIDS	2/ 5/14/ 0/3/0	CLEAR	0.7692	0.5208	0.4386	0.5495	0.5747	0.5263	0.4854	0.4274	0.3625
544	1ST OF 2 SOLIDS	2/ 5/14/ 0/3/0	CLEAR	0.8772	0.8929	0.7813	0.7576	0.6944	0.6329	0.6410	0.5435	0.4310
544	2ND OF 2 SOLIDS	2/ 7/14/ 0/3/0	CLEAR	0.7937	0.9091	0.7353	0.6579	0.6694	0.5747	0.5155	0.4425	0.3817
546	1ST OF 2 SOLIDS	2/ 5/14/ 0/3/0	CLEAR	0.8475	0.7937	0.7266	0.7937	0.7143	0.8621	0.7692	0.7042	0.5051
546	2ND OF 2 SOLIDS	2/ 7/14/ 0/3/0	CLEAR	0.9434	0.7937	0.6944	0.7576	0.7353	0.6944	0.6494	0.6173	0.5455
552	1ST OF 2 SOLIDS	2/ 7/14/ 0/3/0	CLEAR	0.9804	0.9259	0.7143	0.7246	0.6667	0.6250	0.6024	0.4950	0.4854
552	2ND OF 2 SOLIDS	2/ 7/14/ 0/3/0	CLEAR	0.8772	0.9091	0.7813	0.6869	0.7143	0.6667	0.6250	0.5155	0.4717
554	1ST OF 2 SOLIDS	2/ 7/14/ 0/3/0	CLEAR	0.9091	0.9434	0.7576	0.7246	0.7246	0.6579	0.6173	0.5263	0.4348
554	2ND OF 2 SOLIDS	2/ 7/15/ 0/3/0	CLEAR	0.8475	0.8929	0.7692	0.7042	0.6869	0.5814	0.4762	0.4065	0.3311
569	1ST OF 2 SOLIDS	2/ 6/16/ 0/3/0	CLEAR	0.7576	0.8929	0.7937	0.7042	0.6494	0.6098	0.5495	0.4237	0.2459
569	2ND OF 2 SOLIDS	2/ 5/16/ 0/3/0	CLEAR	0.8475	0.9259	0.7576	0.6757	0.6579	0.6173	0.5556	0.4167	0.2242
584	1ST OF 2 SOLIDS	1/ 4/ 6/ 1/2/0	CLEAR	1.2821	0.8929	1.0870	0.6667	0.7143	0.6667	0.5882	0.3846	0.2242
584	2ND OF 2 SOLIDS	2/11/14/ 0/3/0	CLEAR	0.9091	0.8772	0.6173	0.5952	0.5556	0.4762	0.3817	0.2632	0.1520
600	1ST OF 2 SOLIDS	2/ 7/14/ 0/3/0	CLEAR	1.0204	0.9434	0.8475	0.7576	0.6944	0.7143	0.7353	0.5814	0.5319
600	2ND OF 2 SOLIDS	2/ 5/15/ 0/3/0	CLEAR	0.9615	0.9804	0.8197	0.7576	0.7463	0.7353	0.7143	0.5952	0.5263
615	1ST OF 2 SOLIDS	2/10/14/ 0/3/0	CLEAR	0.7937	0.8772	0.7813	0.7246	0.7143	0.6410	0.5882	0.5000	0.4000
615	2ND OF 2 SOLIDS	2/11/13/ 0/3/0	CLEAR	0.8065	0.8772	0.7692	0.7042	0.6757	0.6098	0.5263	0.4065	0.3226

654	1ST OF 2 SOLIDS	2/ 7/15/	0/3/0	CLEAR	0.8772	0.8929	0.8197	0.7463	0.6379	0.6494	0.5102	0.4386	0.3623
654	2ND OF 2 SOLIDS	2/ 5/14/	0/3/0	CLEAR	0.8929	0.9804	0.7492	0.7246	0.6944	0.5952	0.5682	0.4808	0.3788
665	1ST OF 2 SOLIDS	2/ 7/14/	0/3/0	9.420	0.8065	0.8621	0.7143	0.5882	0.4505	0.0000	0.0000	0.0000	0.0000
665	2ND OF 2 SOLIDS	2/ 5/15/	0/3/0	7.670	0.7463	0.6579	0.5816	0.3817	0.0000	0.0000	0.0000	0.0000	0.0000
666	1ST OF 2 SOLIDS	2/ 7/14/	0/3/0	CLEAR	0.0000	0.0000	0.0000	0.0000	0.0000	0.0000	0.6024	0.5051	0.4587
666	2ND OF 2 SOLIDS	2/ 5/15/	0/3/0	CLEAR	0.0000	0.0000	0.0000	0.0000	0.0000	0.5051	0.5747	0.4854	0.4505
688	1ST OF 2 SOLIDS	2/14/15/	0/3/0	CLEAR	0.0000	0.0000	0.0000	0.0000	0.6757	0.6494	0.6173	0.4950	0.4545
688	2ND OF 2 SOLIDS	2/11/14/	0/3/0	CLEAR	0.8197	0.8475	0.6098	0.4950	0.5682	0.4902	0.4902	0.6032	0.3356
702	1ST OF 2 SOLIDS	1/ 0/ 0/22/2/0	CLEAR	0.9804	0.8475	0.6849	0.6849	0.6849	0.6944	0.6098	0.6250	0.4762	0.3106
702	2ND OF 2 SOLIDS	2/12/15/	0/3/0	CLEAR	0.8197	0.8772	0.6944	0.6494	0.6024	0.4854	0.4032	0.2358	0.1754
707	1ST OF 2 SOLIDS	2/11/15/	0/3/0	CLEAR	0.7937	0.8621	0.7143	0.6024	0.5263	0.4132	0.2577	0.2110	0.1603
707	2ND OF 2 SOLIDS	2/11/15/	0/3/0	CLEAR	0.7937	0.8621	0.6757	0.5747	0.4950	0.3704	0.2315	0.2146	0.1433
719	1ST OF 2 SOLIDS	2/ 7/14/	0/3/0	CLEAR	0.8475	0.9434	0.6849	0.6944	0.6379	0.5682	0.5000	0.4032	0.3185
719	2ND OF 2 SOLIDS	2/ 9/14/	0/3/0	CLEAR	0.8333	0.8197	0.7143	0.6944	0.6410	0.5263	0.4762	0.4098	0.3247
726	1ST OF 2 SOLIDS	2/11/14/	0/3/0	CLEAR	0.8065	0.9434	0.7463	0.6849	0.6410	0.5208	0.3401	0.2110	0.2000
726	2ND OF 2 SOLIDS	2/11/14/	0/3/0	CLEAR	0.8065	0.8621	0.7042	0.5208	0.4505	0.2488	0.2252	0.2155	0.1984
730	1ST OF 2 SOLIDS	1/ 5/ 6/ 1/2/0	CLEAR	0.9434	0.7813	0.6667	0.6410	0.0000	0.5682	0.5263	0.3676	0.1272	0.1073
730	2ND OF 2 SOLIDS	2/12/15/21/5/3	5.970	0.7042	0.6757	0.0000	0.0000	0.0000	0.0000	0.0000	0.0000	0.0000	0.0000
751	1ST OF 2 SOLIDS	2/ 7/14/	0/3/0	CLEAR	0.9615	0.9434	0.7813	0.7376	0.6849	0.7353	0.6849	0.5435	0.3788
751	2ND OF 2 SOLIDS	2/11/14/	0/3/0	CLEAR	0.8621	0.9091	0.7576	0.7692	0.7143	0.6024	0.5208	0.4310	0.3817
774	1ST OF 2 SOLIDS	2/11/14/	0/3/0	6.970	0.7937	0.7463	0.6250	0.0000	0.0000	0.0000	0.0000	0.0000	0.0000
774	2ND OF 2 SOLIDS	2/11/15/	0/3/0	6.170	0.7576	0.7042	0.5906	0.0000	0.0000	0.0000	0.0000	0.0000	0.0000
775	1ST OF 2 SOLIDS	2/11/14/	0/3/0	CLEAR	0.0000	0.0000	0.0000	0.0000	0.8333	0.6757	0.5882	0.4386	0.3906
775	2ND OF 2 SOLIDS	2/11/15/	0/3/0	CLEAR	0.0000	0.0000	0.0000	0.0000	0.6849	0.5952	0.5376	0.4202	0.3521
792	1ST OF 2 SOLIDS	2/ 7/14/	0/3/0	CLEAR	0.0000	0.0000	0.0000	0.0000	0.0000	0.0000	0.0000	0.0000	0.5000
792	2ND OF 2 SOLIDS	2/ 5/15/	0/3/0	CLEAR	0.8621	0.8621	0.7576	0.7353	0.7042	0.5882	0.4950	0.3497	0.3049
809	1ST OF 2 SOLIDS	2/15/14/	0/3/0	CLEAR	0.0000	0.0000	0.0000	0.0000	0.0000	0.0000	0.0000	0.5155	0.4587
809	2ND OF 2 SOLIDS	2/ 9/15/	0/3/0	12.470	0.8065	0.7353	0.6579	0.5618	0.4310	0.2618	0.1661	0.1337	0.0800
812	1ST OF 2 SOLIDS	2/ 9/14/	0/3/0	CLEAR	0.7692	0.9259	0.7246	0.6757	0.5102	0.3876	0.2809	0.2242	0.1515
812	2ND OF 2 SOLIDS	2/ 5/14/	0/3/0	CLEAR	0.8197	0.8065	0.7042	0.5618	0.4762	0.3759	0.2874	0.2155	0.1445
816	1ST OF 2 SOLIDS	2/ 9/14/	0/3/0	CLEAR	0.8772	0.9434	0.7937	0.6849	0.6329	0.6173	0.4717	0.2874	0.1938
816	2ND OF 2 SOLIDS	2/ 9/14/	0/3/0	CLEAR	0.7576	0.8065	0.6494	0.5952	0.6545	0.3571	0.2525	0.2381	0.2024
822	1ST OF 2 SOLIDS	2/ 7/14/	0/3/0	CLEAR	0.9804	0.9615	0.7463	0.7246	0.6944	0.6757	0.6410	0.5155	0.4464
822	2ND OF 2 SOLIDS	2/ 7/14/	0/3/0	CLEAR	0.8621	0.8621	0.7353	0.6757	0.6329	0.5495	0.4854	0.3571	0.2674
834	1ST OF 2 SOLIDS	2/ 9/15/	0/3/0	CLEAR	0.0000	0.0000	0.0000	0.0000	0.0000	0.0000	0.0000	0.5618	0.4274
834	2ND OF 2 SOLIDS	2/11/16/	0/3/0	5.190	0.6024	0.3571	0.0000	0.0000	0.0000	0.0000	0.0000	0.0000	0.0000
845	1ST OF 2 SOLIDS	2/ 7/14/	0/3/0	CLEAR	0.0000	0.0000	0.0000	0.0000	0.0000	0.8333	0.7246	0.7042	0.6944
845	2ND OF 2 SOLIDS	2/ 4/13/	0/3/0	CLEAR	0.8197	0.8475	0.6944	0.5000	0.4505	0.4167	0.3311	0.1742	0.1359
854	1ST OF 2 SOLIDS	2/ 9/14/	0/3/0	CLEAR	0.9804	0.9434	0.7692	0.7937	0.6944	0.7246	0.7042	0.5682	0.4673
854	2ND OF 2 SOLIDS	2/ 9/14/	0/3/0	CLEAR	0.9091	0.9259	0.7246	0.7576	0.6579	0.5556	0.5435	0.4630	0.3731
857	1ST OF 2 SOLIDS	2/ 5/13/	0/3/0	10.740	0.7463	0.8621	0.7463	0.7042	0.6757	0.5495	0.3472	0.0000	0.0000
857	2ND OF 2 SOLIDS	2/ 9/14/	0/3/0	7.640	0.7463	0.7813	0.6757	0.4664	0.0000	0.0000	0.0000	0.0000	0.0000
863	1ST OF 2 SOLIDS	2/ 5/15/	0/3/0	CLEAR	0.8475	0.9434	0.7576	0.6579	0.6024	0.4950	0.3597	0.2273	0.2273
863	2ND OF 2 SOLIDS	2/ 5/15/	0/3/0	CLEAR	0.7813	0.7937	0.6494	0.5495	0.4425	0.3521	0.2793	0.2222	0.2092

662	1ST	UF	3	SOLIDS	1/ 3/ 6/ 1/2/0	10.005	0.8333	0.9259	0.7042	0.6329	0.4505	0.3165	0.0000	0.0000	0.0000	
662	2ND	UF	3	SOLIDS	1/ 3/ 6/ 1/2/0	9.620	0.8065	0.8333	0.6849	0.6250	0.4950	0.2732	0.0000	0.0000	0.0000	
662	3RD	UF	3	SOLIDS	2/12/14/ 0/5/0	9.550	0.7576	0.7937	0.6579	0.5495	0.4098	0.2463	0.0000	0.0000	0.0000	
668	1ST	UF	3	SOLIDS	1/ 0/ 0/ 5/2/0	7.970	0.7813	0.7692	0.8197	0.5495	0.0000	0.0000	0.0000	0.0000	0.0000	
668	2ND	UF	3	SOLIDS	1/ 5/ 6/ 1/2/0	7.870	0.7813	0.7246	0.7246	0.4854	0.0000	0.0000	0.0000	0.0000	0.0000	
668	3RD	UF	3	SOLIDS	2/10/15/ 0/5/0	7.770	0.7937	0.7463	0.5376	0.3623	0.0000	0.0000	0.0000	0.0000	0.0000	
670	1ST	UF	3	SOLIDS	1/ 4/ 8/ 1/2/0	8.530	0.9615	0.9259	0.8333	0.7813	0.6579	0.0000	0.0000	0.0000	0.0000	0.0000
670	2ND	UF	3	SOLIDS	2/ 7/14/ 0/5/0	8.470	0.9615	0.9091	0.8333	0.7576	0.6494	0.0000	0.0000	0.0000	0.0000	0.0000
670	3RD	UF	3	SOLIDS	2/ 7/14/ 0/5/0	8.060	0.7813	0.8772	0.7463	0.5952	0.0000	0.0000	0.0000	0.0000	0.0000	0.0000
813	1ST	UF	3	SOLIDS	1/ 3/ 4/ 1/1/0	CLEAR	0.9434	1.1628	0.9615	0.8772	0.7692	0.7937	0.6410	0.6410	0.5747	0.5000
813	2ND	UF	3	SOLIDS	2/ 9/14/ 0/5/0	CLEAR	0.8929	0.9804	0.7937	0.7937	0.7163	0.6757	0.0000	0.5814	0.5000	0.0000
813	3RD	UF	3	SOLIDS	2/ 7/14/ 0/5/0	6.820	0.5556	0.3906	0.1946	0.0000	0.0000	0.0000	0.0000	0.0000	0.0000	0.0000
951	1ST	UF	3	SOLIDS	1/ 3/ 8/ 1/2/0	10.750	0.8621	0.8772	0.7813	0.7246	0.6250	0.5263	0.1887	0.0000	0.0000	0.0000
951	2ND	UF	3	SOLIDS	2/ 7/14/ 0/5/0	10.700	0.8475	0.9091	0.7576	0.7246	0.5882	0.5435	0.1799	0.0000	0.0000	0.0000
951	3RD	UF	3	SOLIDS	2/ 7/14/ 0/5/0	10.540	1.2821	0.8065	0.7576	0.6410	0.5814	0.4762	0.1046	0.0000	0.0000	0.0000
953	1ST	UF	3	SOLIDS	2/ 5/14/ 0/5/0	CLEAR	0.8475	0.8197	0.7353	0.6757	0.6410	0.5882	0.4902	0.4032	0.3165	0.2404
953	2ND	UF	3	SOLIDS	2/ 5/16/ 0/5/0	CLEAR	0.7937	0.8333	0.6849	0.5882	0.5000	0.4032	0.2825	0.2762	0.2660	0.1984
953	3RD	UF	3	SOLIDS	2/ 7/14/ 0/5/0	CLEAR	0.8065	0.7937	0.6494	0.4902	0.4132	0.3205	0.2841	0.2907	0.2500	0.1497
954	1ST	UF	3	SOLIDS	2/11/14/ 0/5/0	CLEAR	0.8333	1.0204	0.8772	0.6667	0.6494	0.6024	0.5000	0.3876	0.2404	0.1984
954	2ND	UF	3	SOLIDS	2/ 9/14/ 0/5/0	CLEAR	0.9434	0.7813	0.7042	0.6667	0.5882	0.5000	0.3817	0.2941	0.1984	0.1497
954	3RD	UF	3	SOLIDS	2/11/14/ 0/5/0	CLEAR	0.7813	0.7143	0.5495	0.5311	0.2304	0.1618	0.1558	0.1748	0.1497	0.1119
989	1ST	UF	3	SOLIDS	1/ 0/ 0/22/2/0	CLEAR	0.8929	0.8772	0.7463	0.7463	0.6329	0.5952	0.0000	0.4545	0.3846	0.3000
989	2ND	UF	3	SOLIDS	2/ 7/14/ 0/5/0	10.470	0.8475	0.8772	0.7576	0.7353	0.6098	0.5208	0.2513	0.0000	0.0000	0.0000
989	3RD	UF	3	SOLIDS	2/ 5/14/ 0/5/0	6.470	0.8065	0.7463	0.4425	0.0000	0.0000	0.0000	0.0000	0.0000	0.0000	0.0000
269	1ST	UF	4	SOLIDS	1/ 2/ 2/ 1/1/0	CLEAR	1.0417	0.9804	0.8475	0.7463	0.7576	0.7463	0.6667	0.6173	0.5747	0.5263
269	2ND	UF	4	SOLIDS	1/ 5/ 2/ 1/1/0	CLEAR	1.0417	0.9615	0.8621	0.7353	0.7576	0.7246	0.6667	0.6024	0.5263	0.4545
269	3RD	UF	4	SOLIDS	2/ 7/15/ 0/5/0	CLEAR	0.9434	0.8772	0.7692	0.7143	0.7042	0.6250	0.5747	0.4167	0.2033	0.1555
269	4TH	UF	4	SOLIDS	2/ 7/15/ 0/5/0	CLEAR	0.8333	0.8475	0.7143	0.6579	0.6173	0.5263	0.3731	0.2242	0.1119	0.0696
281	1ST	UF	4	SOLIDS	1/ 0/ 0/21/1/0	CLEAR	1.1364	0.9434	0.8621	0.8475	0.8065	0.7937	0.7246	0.6849	0.5952	0.4000
281	2ND	UF	4	SOLIDS	1/ 3/ 6/ 1/1/0	CLEAR	1.2195	0.8772	0.8621	0.7813	0.7463	0.6944	0.6579	0.6329	0.5155	0.3497
281	3RD	UF	4	SOLIDS	1/ 0/ 0/ 3/1/0	CLEAR	1.3889	1.0417	0.8333	0.7937	0.5952	0.6667	0.6000	0.0000	0.0000	0.0000
281	4TH	UF	4	SOLIDS	2/11/15/ 0/5/0	CLEAR	0.8065	0.7937	0.7143	0.5319	0.4587	0.2370	0.0000	0.0000	0.0000	0.0000
292	1ST	UF	4	SOLIDS	1/ 2/ 4/ 1/2/0	CLEAR	0.8772	0.9091	0.7692	0.6579	0.6329	0.6579	0.6757	0.6757	0.6000	0.4000
292	2ND	UF	4	SOLIDS	1/ 4/ 6/ 1/2/0	CLEAR	0.8621	0.7937	0.7576	0.6667	0.6579	0.6849	0.6098	0.5747	0.3497	0.3000
292	3RD	UF	4	SOLIDS	1/ 6/ 6/ 1/2/0	9.940	0.8929	0.8621	0.7937	0.6757	0.6329	0.5102	0.0000	0.0000	0.0000	0.0000
292	4TH	UF	4	SOLIDS	2/11/14/ 0/5/0	9.860	0.7813	0.7813	0.6757	0.5952	0.3604	0.1475	0.0000	0.0000	0.0000	0.0000
336	1ST	UF	4	SOLIDS	1/ 2/ 4/ 1/1/0	CLEAR	1.5152	0.9615	0.7576	0.7576	0.7353	0.7353	0.7143	0.6849	0.5319	0.4348
336	2ND	UF	4	SOLIDS	1/ 1/ 2/ 1/1/0	CLEAR	1.3153	1.0000	0.8065	0.7376	0.6250	0.6250	0.6410	0.6410	0.5618	0.4545
336	3RD	UF	4	SOLIDS	1/ 5/ 5/ 1/1/0	CLEAR	1.2500	0.9615	0.7813	0.7042	0.6849	0.7353	0.6329	0.4545	0.6310	0.4545
336	4TH	UF	4	SOLIDS	2/13/16/ 0/3/0	6.470	0.1244	0.0000	0.0000	0.0000	0.0000	0.0000	0.0000	0.0000	0.0000	0.0000
481	1ST	UF	4	SOLIDS	2/11/14/ 0/5/0	CLEAR	0.0000	0.0000	0.0000	0.5682	0.7246	0.6410	0.6250	0.6849	0.4348	0.3000
481	2ND	UF	4	SOLIDS	1/ 0/ 0/ 3/1/0	CLEAR	1.0204	1.1628	0.7937	0.7163	0.6849	0.6410	0.5814	0.5000	0.2793	0.2000
481	3RD	UF	4	SOLIDS	1/ 0/ 0/ 3/1/0	CLEAR	0.9434	1.0638	0.8197	0.6494	0.6849	0.5747	0.4202	0.3788	0.2315	0.1555
481	4TH	UF	4	SOLIDS	2/14/14/25/3/2	12.505	0.8929	1.1111	0.7576	0.6250	0.6329	0.5814	0.3672	0.1445	0.1282	0.0696
608	1ST	UF	4	SOLIDS	1/ 7/ 4/ 1/2/0	CLEAR	1.1111	1.0870	0.7937	0.7937	0.8197	0.7463	0.6667	0.6410	0.5618	0.4545
608	2ND	UF	4	SOLIDS	1/ 0/ 0/21/2/0	CLEAR	1.0870	0.9615	0.8065	0.7692	0.7576	0.7042	0.6757	0.6410	0.5618	0.4545
608	3RD	UF	4	SOLIDS	2/ 9/13/ 0/5/0	CLEAR	0.8772	0.9434	0.8197	0.7813	0.6944	0.6579	0.6410	0.5747	0.4673	0.3497
608	4TH	UF	4	SOLIDS	1/ 3/ 6/ 1/2/0	CLEAR	1.0204	1.0000	0.8333	0.7576	0.6944	0.6410	0.6250	0.5495	0.4505	0.3000
626	1ST	UF	4	SOLIDS	1/ 5/ 6/ 1/2/0	CLEAR	0.0000	0.0000	0.0000	0.0000	0.0000	0.0000	0.0000	0.0000	0.4310	0.3000
626	2ND	UF	4	SOLIDS	1/ 3/ 8/ 1/2/0	CLEAR	0.0000	0.0000	0.0000	0.0000	0.0000	0.0000	0.0000	0.0000	0.4310	0.3000
626	3RD	UF	4	SOLIDS	2/ 7/14/ 0/5/0	CLEAR	0.0000	0.0000	0.0000	0.0000	0.0000	0.0000	0.0000	0.0000	0.4310	0.3000

626	4TH OF 4 SOLIDS	2/ 7/14/ 0/3/0	CLEAR	0.9454	1.1628	0.7353	0.7042	0.6667	0.4717	0.4167	0.4032	0.3226
663	1ST UF 4 SOLIDS	1/ 3/ 6/ 1/2/0	CLEAR	0.0000	0.0000	0.0000	0.0000	0.0000	0.0000	0.0000	0.4000	0.3311
663	2ND UF 4 SOLIDS	1/ 3/ 6/ 1/2/0	CLEAR	0.0000	0.0000	0.0000	0.0000	0.0000	0.0000	0.0000	0.4032	0.3289
663	3RD UF 4 SOLIDS	2/12/14/ 0/3/0	CLEAR	0.0000	0.0000	0.0000	0.0000	0.0000	0.0000	0.0000	0.4098	0.3205
663	4TH UF 4 SOLIDS	2/ 7/15/ 0/3/0	CLEAR	0.6197	0.9804	0.7692	0.7246	0.6757	0.4505	0.3623	0.3356	0.2451
671	1ST UF 4 SOLIDS	1/ 4/ 8/ 1/2/0	CLEAR	0.0000	0.0000	0.0000	0.0000	0.0000	0.0000	0.4310	0.5319	0.5876
671	2ND UF 4 SOLIDS	2/ 7/14/ 0/3/0	CLEAR	0.0000	0.0000	0.0000	0.0000	0.0000	0.0000	0.4310	0.5263	0.3846
671	3RD UF 4 SOLIDS	2/ 7/14/ 0/3/0	CLEAR	0.0000	0.0000	0.0000	0.0000	0.0000	0.4274	0.5263	0.4505	0.3817
671	4TH UF 4 SOLIDS	2/ 9/14/ 0/3/0	CLEAR	0.8621	0.7143	0.5263	0.4310	0.3049	0.3289	0.3571	0.3125	0.2874
804	1ST UF 4 SOLIDS	1/ 0/ 0/30/1/0	CLEAR	0.9804	0.9259	0.7937	0.7813	0.8621	0.8333	0.7042	0.7042	0.6410
804	2ND UF 4 SOLIDS	2/ 5/15/ 0/3/0	5.670	0.6098	0.3937	0.0000	0.0000	0.0000	0.0000	0.0000	0.0000	0.0000
804	3RD UF 4 SOLIDS	2/ 5/15/ 0/3/0	5.555	0.5814	0.3704	0.0000	0.0000	0.0000	0.0000	0.0000	0.0000	0.0000
804	4TH UF 4 SOLIDS	2/ 5/15/ 0/3/0	5.310	0.5208	0.3289	0.0000	0.0000	0.0000	0.0000	0.0000	0.0000	0.0000
811	1ST UF 4 SOLIDS	2/ 1/ 5/14/5/3	CLEAR	0.7937	0.7937	0.7143	0.6849	0.5208	0.4065	0.2841	0.1901	0.1362
811	2ND UF 4 SOLIDS	1/ 3/ 6/ 1/2/0	CLEAR	0.9091	0.8772	0.7042	0.6494	0.4902	0.3704	0.2525	0.1825	0.1289
811	3RD UF 4 SOLIDS	2/ 7/14/ 0/3/0	CLEAR	0.8065	0.8621	0.6579	0.6173	0.5102	0.3759	0.2762	0.1887	0.1279
811	4TH UF 4 SOLIDS	1/ 3/ 4/ 1/2/0	CLEAR	0.8197	0.8929	0.6667	0.5556	0.5263	0.3650	0.2381	0.1984	0.1292
829	1ST UF 4 SOLIDS	2/ 1/14/ 0/3/0	CLEAR	0.0000	0.0000	0.0000	0.0000	0.0000	0.0000	0.6494	0.5747	0.5000
829	2ND UF 4 SOLIDS	2/ 7/14/ 0/3/0	CLEAR	0.0000	0.0000	0.0000	0.0000	0.0000	0.0000	0.6667	0.5618	0.4902
829	3RD UF 4 SOLIDS	2/10/14/ 0/3/0	CLEAR	0.0000	0.0000	0.0000	0.8065	0.5155	0.4717	0.5747	0.5814	0.4808
829	4TH UF 4 SOLIDS	2/13/14/ 0/3/0	CLEAR	0.8065	0.8929	0.6944	0.6024	0.5495	0.3968	0.3311	0.2326	0.1953
858	1ST UF 4 SOLIDS	2/ 3/13/ 0/3/0	CLEAR	0.0000	0.0000	0.0000	0.0000	0.0000	0.0000	0.0000	0.0000	0.3049
858	2ND UF 4 SOLIDS	2/ 9/14/ 0/3/0	CLEAR	0.0000	0.0000	0.0000	0.0000	0.0000	0.5155	0.4854	0.3571	0.2688
858	3RD UF 4 SOLIDS	2/ 1/14/ 0/3/0	CLEAR	0.7353	0.8333	0.6173	0.5155	0.2825	0.1563	0.1071	0.1119	0.1229
858	4TH UF 4 SOLIDS	2/ 9/14/ 0/3/0	CLEAR	0.7353	0.8333	0.6173	0.4673	0.2564	0.1385	0.0847	0.1142	0.0760
3	1ST UF 5 SOLIDS	1/ 0/ 0/11/1/0	CLEAR	1.0000	0.8772	0.8929	0.6757	0.7937	0.6667	0.6579	0.5747	0.4854
3	2ND UF 5 SOLIDS	1/ 0/ 0/22/1/0	7.400	0.8621	0.6849	0.6173	0.5906	0.0000	0.0000	0.0000	0.0000	0.0000
3	3RD UF 5 SOLIDS	2/13/14/ 0/3/0	6.930	0.7353	0.6849	0.5263	0.0000	0.0000	0.0000	0.0000	0.0000	0.0000
3	4TH UF 5 SOLIDS	1/ 3/ 8/ 1/2/0	6.620	0.7353	0.6410	0.4464	0.0000	0.0000	0.0000	0.0000	0.0000	0.0000
3	5TH UF 5 SOLIDS	2/11/14/ 0/3/0	6.570	0.7246	0.6494	0.4386	0.0000	0.0000	0.0000	0.0000	0.0000	0.0000
38	1ST UF 5 SOLIDS	1/ 0/ 0/ 4/1/0	CLEAR	1.2821	0.9804	0.9615	0.8197	0.5747	0.7813	0.6173	0.6329	0.4950
38	2ND UF 5 SOLIDS	1/ 3/ 8/ 1/2/0	9.490	1.0638	0.8333	0.7937	0.5814	0.5814	0.4274	0.0000	0.0000	0.0000
38	3RD UF 5 SOLIDS	2/ 7/14/ 0/3/0	9.440	0.8621	0.7813	0.7042	0.6494	0.2674	0.4717	0.0000	0.0000	0.0000
38	4TH UF 5 SOLIDS	2/ 7/14/ 0/3/0	9.290	0.7576	0.7246	0.6757	0.3937	0.2193	0.3012	0.0000	0.0000	0.0000
38	5TH UF 5 SOLIDS	2/ 7/14/ 0/3/0	9.140	0.7692	0.7353	0.4854	0.3448	0.1908	0.1587	0.0000	0.0000	0.0000
122	1ST UF 5 SOLIDS	2/10/15/ 0/3/0	CLEAR	0.0000	0.0000	0.0000	0.0000	0.0000	0.0000	0.0000	0.0000	0.4854
122	2ND UF 5 SOLIDS	1/ 0/ 0/21/1/0	CLEAR	1.2195	1.0638	0.7246	0.6329	0.5747	0.4098	0.3067	0.3472	0.3521
122	3RD UF 5 SOLIDS	2/ 7/14/ 0/3/0	CLEAR	0.8475	0.8475	0.7813	0.6757	0.6098	0.4032	0.3125	0.3333	0.2488
122	4TH UF 5 SOLIDS	1/ 0/ 0/ 3/1/0	CLEAR	0.7937	0.8197	0.6944	0.6579	0.5000	0.3817	0.2717	0.2326	0.1592
122	5TH UF 5 SOLIDS	2/ 9/14/ 0/3/0	CLEAR	0.7937	0.7937	0.6944	0.5682	0.4950	0.3401	0.2024	0.1603	0.1567
155	1ST UF 5 SOLIDS	1/ 4/ 5/ 1/2/0	CLEAR	1.5152	1.0417	0.7692	0.6944	0.7042	0.6098	0.6329	0.3731	0.3049
155	2ND UF 5 SOLIDS	1/ 4/ 5/ 1/2/0	CLEAR	1.4286	0.9091	0.7692	0.7463	0.7042	0.6410	0.6098	0.3731	0.2941
155	3RD UF 5 SOLIDS	1/ 0/ 0/30/2/0	CLEAR	1.1628	0.7937	0.8065	0.6944	0.6667	0.7246	0.4587	0.2841	0.1701
155	4TH UF 5 SOLIDS	1/ 4/ 5/ 1/2/0	CLEAR	0.8333	0.9259	0.7463	0.6579	0.6379	0.5000	0.3247	0.1786	0.1894
155	5TH UF 5 SOLIDS	2/11/14/23/3/2	CLEAR	0.8772	0.8333	0.6944	0.6849	0.5208	0.4202	0.2778	0.1786	0.1558
173	1ST UF 5 SOLIDS	1/ 2/ 4/ 1/2/0	CLEAR	1.3889	1.0000	0.7576	0.6944	0.7692	1.0000	0.6849	0.4587	0.4387
173	2ND UF 5 SOLIDS	1/ 0/ 0/22/2/0	10.020	1.2195	0.7143	0.7353	0.7692	0.5814	0.4587	0.0000	0.0000	0.0000
173	3RD UF 5 SOLIDS	1/ 3/ 6/ 1/2/0	9.820	1.1111	0.7813	0.7353	0.5682	0.5556	0.3571	0.0000	0.0000	0.0000
173	4TH UF 5 SOLIDS	1/ 7/ 6/ 1/2/0	9.770	0.8333	0.7937	0.6757	0.6173	0.4854	0.2632	0.0000	0.0000	0.0000
173	5TH UF 5 SOLIDS	2/12/14/ 0/3/0	9.620	0.7576	0.7937	0.6667	0.5319	0.4202	0.2513	0.0000	0.0000	0.0000
179	1ST UF 5 SOLIDS	1/ 3/ 8/ 1/2/0	CLEAR	1.3158	0.9804	0.8929	0.8621	0.8675	0.8197	0.7353	0.6173	0.6329
179	2ND UF 5 SOLIDS	2/ 7/14/ 0/3/0	CLEAR	1.3514	0.9634	0.8621	0.8065	0.7813	0.6579	0.6667	0.6250	0.4902
179	3RD UF 5 SOLIDS	2/ 5/14/ 0/3/0	CLEAR	0.9259	0.9434	0.8621	0.7246	0.7576	0.6944	0.6757	0.5882	0.5000
179	4TH UF 5 SOLIDS	2/ 9/14/ 0/3/0	CLEAR	0.9434	0.9091	0.7937	0.7576	0.6944	0.6944	0.6024	0.5495	0.4950

179	5TH OF 5 SOLIDS	1/ 1/ 2/ 1/2/0	CLEAR	0.9615	0.8772	0.7692	0.7463	0.7246	0.6944	0.5882	0.5206	0.4902
300	1ST UF 5 SOLIDS	1/ 0/ 0/12/1/0	CLEAR	1.1364	0.9804	0.7463	0.9259	0.7813	0.7813	0.7576	0.6173	0.5814
300	2ND UF 5 SOLIDS	1/ 3/ 6/ 1/2/0	CLEAR	1.1628	0.8621	0.8065	0.7353	0.6944	0.6849	0.5618	0.4673	0.3356
300	3RD UF 5 SOLIDS	1/ 5/ 6/ 1/2/0	CLEAR	0.9615	0.9259	0.7353	0.6667	0.7042	0.5814	0.4545	0.3731	0.3165
300	4TH UF 5 SOLIDS	1/ 7/ 6/ 1/2/0	12.000	0.9259	0.9615	0.6944	0.6757	0.6329	0.5495	0.4587	0.3497	0.0000
300	5TH UF 5 SOLIDS	2/ 7/14/ 0/5/0	11.850	0.9091	0.8929	0.7246	0.7353	0.5319	0.5356	0.4505	0.3846	0.0000
574	1ST UF 5 SOLIDS	1/ 2/ 4/ 1/2/0	CLEAR	0.9434	0.8621	0.7692	0.6849	0.7353	0.7246	0.5263	0.6098	0.5495
574	2ND UF 5 SOLIDS	1/ 2/ 4/ 1/2/0	CLEAR	0.9434	0.9434	0.7813	0.6849	0.7246	0.7246	0.5263	0.6175	0.5556
574	3RD UF 5 SOLIDS	1/ 2/ 4/ 1/2/0	CLEAR	0.9259	0.9091	0.6667	0.6849	0.7576	0.6098	0.4950	0.5618	0.4854
574	4TH UF 5 SOLIDS	2/ 4/14/ 0/5/0	CLEAR	0.9434	0.8929	0.6494	0.6757	0.6849	0.6250	0.5000	0.5625	0.2273
574	5TH UF 5 SOLIDS	1/ 4/ 5/ 1/2/0	9.450	0.8475	0.7692	0.7246	0.6579	0.5263	0.4673	0.0000	0.0000	0.0000
606	1ST UF 5 SOLIDS	1/ 0/ 0/ 3/1/0	CLEAR	1.3889	1.0638	0.8197	0.8333	0.7353	0.6944	0.6944	0.6757	0.5814
606	2ND UF 5 SOLIDS	1/ 2/ 4/ 1/1/0	CLEAR	1.0000	1.0000	0.7576	0.7576	0.7692	0.8065	0.6250	0.6494	0.5495
606	3RD UF 5 SOLIDS	1/ 0/ 0/ 4/1/0	CLEAR	0.8929	0.9259	0.7576	0.6579	0.6173	0.5952	0.5208	0.4505	0.3706
606	4TH UF 5 SOLIDS	1/ 5/ 6/ 1/2/0	7.370	0.8475	0.7353	0.6173	0.3648	0.0000	0.0000	0.0000	0.0000	0.0000
606	5TH UF 5 SOLIDS	2/ 5/15/ 0/5/0	7.270	0.8333	0.7246	0.6098	0.2660	0.0000	0.0000	0.0000	0.0000	0.0000
763	1ST UF 5 SOLIDS	1/ 7/ 8/ 1/2/0	11.870	0.0000	0.0000	0.0000	0.0000	0.0000	0.0000	0.0000	0.0000	0.0000
763	2ND UF 5 SOLIDS	2/11/14/ 4/5/3	11.730	0.0000	0.0000	0.0000	0.0000	0.0000	0.0000	0.0000	0.0000	0.0000
763	3RD UF 5 SOLIDS	2/13/14/ 0/5/0	11.490	0.0000	0.0000	0.0000	0.0000	0.0000	0.0000	0.0000	0.0000	0.0000
763	4TH UF 5 SOLIDS	2/ 7/14/ 0/5/0	11.210	0.0000	0.0000	0.0000	0.0000	0.0000	0.0000	0.0000	0.0000	0.0000
763	5TH UF 5 SOLIDS	2/ 7/14/ 0/5/0	10.590	0.8475	0.9259	0.7576	0.6667	0.6329	0.5495	0.4202	0.0000	0.0000
814	1ST OF 5 SOLIDS	2/ 7/14/ 0/5/0	CLEAR	0.0000	0.0000	0.0000	0.0000	0.7353	0.6757	0.7246	0.6250	0.5102
814	2ND OF 5 SOLIDS	1/ 3/ 6/ 1/1/0	CLEAR	0.7692	0.7143	0.7042	0.6098	0.7042	0.6757	0.6173	0.5376	0.4545
814	3RD OF 5 SOLIDS	1/ 5/ 6/ 1/2/0	10.730	0.8533	0.7937	0.7246	0.6410	0.5155	0.4854	0.1044	0.0000	0.0000
814	4TH OF 5 SOLIDS	2/ 7/15/ 0/5/0	10.630	0.8533	0.7937	0.7246	0.6024	0.5155	0.3788	0.0926	0.0000	0.0000
814	5TH OF 5 SOLIDS	2/ 7/15/ 0/5/0	10.480	0.8333	0.8065	0.6944	0.5682	0.5208	0.3012	0.0856	0.0000	0.0000
932	1ST OF 5 SOLIDS	6/ 0/ 0/ 0/0/0	CLEAR	0.0000	0.0000	0.0000	0.0000	0.0000	0.6944	0.7143	0.5319	0.5051
932	2ND OF 5 SOLIDS	4/ 0/ 0/31/0/0	CLEAR	0.9615	0.8929	0.7692	0.8197	0.7143	0.7246	0.6944	0.5814	0.4950
932	3RD OF 5 SOLIDS	6/ 0/ 0/ 0/0/0	CLEAR	0.8772	1.0000	0.7576	0.8197	0.7353	0.6757	0.6849	0.5682	0.4808
932	4TH OF 5 SOLIDS	2/ 5/14/ 0/5/0	CLEAR	0.7937	0.8772	0.7042	0.6250	0.5263	0.3759	0.2358	0.1825	0.1222
932	5TH OF 5 SOLIDS	2/ 5/14/ 0/5/0	6.470	0.7576	0.7463	0.4425	0.0000	0.0000	0.0000	0.0000	0.0000	0.0000
1003	1ST OF 5 SOLIDS	1/ 0/ 0/24/2/0	CLEAR	1.0417	1.0417	0.7042	0.5952	0.7143	0.6757	0.5882	0.4717	0.3497
1003	2ND OF 5 SOLIDS	1/ 3/ 6/ 1/2/0	6.930	0.8621	0.6329	0.6757	0.0000	0.0000	0.0000	0.0000	0.0000	0.0000
1003	3RD OF 5 SOLIDS	2/11/15/ 0/5/0	6.870	0.8333	0.5495	0.4630	0.0000	0.0000	0.0000	0.0000	0.0000	0.0000
1003	4TH OF 5 SOLIDS	1/ 5/ 8/ 1/2/0	6.670	0.7692	0.6667	0.4274	0.0000	0.0000	0.0000	0.0000	0.0000	0.0000
1003	5TH OF 5 SOLIDS	2/12/14/ 0/5/0	6.590	0.7576	0.6579	0.4132	0.0000	0.0000	0.0000	0.0000	0.0000	0.0000
178	1ST OF 6 SOLIDS	1/ 3/ 4/ 1/2/0	CLEAR	1.2500	1.0638	1.0204	0.8929	0.6410	0.8772	0.8065	0.6757	0.6667
178	2ND OF 6 SOLIDS	1/ 0/ 0/11/1/0	CLEAR	1.4706	1.0870	1.0204	0.8929	0.6410	0.8772	0.7143	0.5556	0.7143
178	3RD OF 6 SOLIDS	2/ 7/14/ 0/5/0	CLEAR	0.8929	0.8475	0.7692	0.6757	0.6173	0.5319	0.4098	0.2959	0.2273
178	4TH OF 6 SOLIDS	1/ 0/ 0/ 9/1/0	CLEAR	0.8475	0.7692	0.9091	0.6173	0.5618	0.5263	0.3401	0.2841	0.2262
178	5TH OF 6 SOLIDS	2/ 9/14/ 0/5/0	CLEAR	0.7937	0.7463	0.6329	0.5435	0.4673	0.3788	0.2994	0.2793	0.2427
178	6TH OF 6 SOLIDS	1/ 0/ 0/ 4/1/0	CLEAR	0.9804	0.6944	0.5051	0.5495	0.3788	0.4132	0.3623	0.3165	0.2538
317	1ST OF 6 SOLIDS	1/ 0/ 0/21/1/0	CLEAR	1.1628	0.9804	0.7937	0.7353	0.7246	0.7042	0.6579	0.6494	0.4950
317	2ND OF 6 SOLIDS	1/ 0/ 0/21/1/0	CLEAR	0.8772	0.8929	0.6579	0.6579	0.6667	0.6329	0.4464	0.3356	0.2488
317	3RD OF 6 SOLIDS	1/ 3/ 6/ 1/1/0	CLEAR	0.9434	0.8475	0.7576	0.6757	0.6667	0.5618	0.4032	0.3049	0.2092
317	4TH OF 6 SOLIDS	2/ 9/14/ 0/5/0	CLEAR	0.9259	0.8065	0.7692	0.6849	0.6579	0.5319	0.4132	0.3067	0.2066
317	5TH OF 6 SOLIDS	1/ 3/ 6/ 1/1/0	CLEAR	0.8197	0.8772	0.7692	0.6849	0.6757	0.5051	0.3968	0.2890	0.1946
317	6TH OF 6 SOLIDS	2/ 9/14/ 0/5/0	CLEAR	0.8065	0.8197	0.7463	0.6024	0.5263	0.4808	0.3759	0.2874	0.1887
331	1ST OF 6 SOLIDS	1/ 0/ 0/21/1/0	CLEAR	1.1628	1.0638	0.8065	0.7576	0.9434	0.6757	0.6329	0.5882	0.5435
331	2ND OF 6 SOLIDS	1/ 0/ 0/10/1/0	CLEAR	1.0870	0.9615	0.8333	0.7692	0.7692	0.7042	0.6329	0.5556	0.5263
331	3RD OF 6 SOLIDS	1/ 0/ 0/21/1/0	CLEAR	1.0000	0.9804	0.7937	0.7692	0.6944	0.6494	0.6024	0.5682	0.4762
331	4TH OF 6 SOLIDS	1/ 2/ 4/ 1/1/0	CLEAR	0.8475	0.8929	0.8333	0.6410	0.6329	0.5952	0.4854	0.3378	0.2924
331	5TH OF 6 SOLIDS	2/11/14/ 0/5/0	CLEAR	0.8475	0.8929	0.8197	0.6494	0.6250	0.5882	0.4762	0.3356	0.2890
331	6TH OF 6 SOLIDS	1/ 2/ 4/ 1/1/0	CLEAR	0.9434	0.8929	0.7246	0.6494	0.5952	0.5495	0.4202	0.3247	0.2525
562	1ST OF 6 SOLIDS	1/ 0/ 0/21/2/0	9.870	0.9434	1.1111	0.7463	0.4274	0.0000	0.0000	0.0000	0.0000	0.0000

362	2ND OF 6 SOLIDS	1/ 2/ 4/ 1/2/0	9.640	0.6329	0.7143	0.6250	0.6579	0.5814	0.5155	0.0000	0.0000	0.0000	0.0000
362	3RD OF 6 SOLIDS	1/ 2/ 4/ 1/2/0	9.510	0.6329	0.6944	0.6849	0.6024	0.5556	0.5000	0.0000	0.0000	0.0000	0.0000
362	4TH OF 6 SOLIDS	1/ 6/ 6/ 1/2/0	9.470	0.6579	0.6694	0.6410	0.5682	0.5102	0.4587	0.0000	0.0000	0.0000	0.0000
362	5TH OF 6 SOLIDS	1/ 5/ 6/ 1/2/0	6.470	0.7042	0.6944	0.4762	0.0000	0.0000	0.0000	0.0000	0.0000	0.0000	0.0000
362	6TH OF 6 SOLIDS	2/11/14/ 0/3/0	5.470	0.7042	0.6024	0.0000	0.0000	0.0000	0.0000	0.0000	0.0000	0.0000	0.0000
492	1ST OF 6 SOLIDS	1/ 2/ 4/ 1/2/0	CLEAR	1.1364	0.9259	0.8475	0.8675	0.8065	0.7353	0.6667	0.5682	0.4950	0.4950
492	2ND OF 6 SOLIDS	1/ 4/ 6/ 1/2/0	CLEAR	1.1364	0.9259	0.8475	0.8675	0.7937	0.5682	0.4902	0.4902	0.3012	0.3012
492	3RD OF 6 SOLIDS	2/11/14/ 0/3/0	CLEAR	0.9634	0.9259	0.8333	0.7353	0.6494	0.5155	0.3937	0.3937	0.3788	0.3788
492	4TH OF 6 SOLIDS	1/ 3/ 6/ 1/2/0	CLEAR	0.9615	0.9804	0.8065	0.7062	0.6329	0.5882	0.4950	0.3817	0.3623	0.3623
492	5TH OF 6 SOLIDS	1/ 2/ 4/ 1/2/0	CLEAR	0.9434	0.9434	0.8197	0.6869	0.6667	0.5814	0.4950	0.3846	0.3521	0.3521
492	6TH OF 6 SOLIDS	1/ 4/ 6/ 1/2/0	CLEAR	0.9259	0.9259	0.8333	0.6869	0.6667	0.5814	0.4950	0.3876	0.3448	0.3448
492	7TH OF 6 SOLIDS	1/ 5/ 6/ 1/2/0	CLEAR	1.0870	1.0000	0.6329	0.6869	0.7692	0.6757	0.6757	0.4808	0.2183	0.2183
492	2ND OF 7 SOLIDS	1/ 2/ 4/ 1/2/0	CLEAR	0.9091	0.9615	0.6410	0.7353	0.6944	0.6329	0.6329	0.4237	0.2336	0.2336
492	3RD OF 7 SOLIDS	1/ 2/ 4/ 1/2/0	CLEAR	0.9259	0.9434	0.6410	0.7163	0.6757	0.5952	0.4237	0.2336	0.2336	0.2336
492	4TH OF 7 SOLIDS	1/ 7/ 8/ 1/2/0	CLEAR	0.9259	0.9615	0.6329	0.7163	0.6869	0.5814	0.4237	0.2336	0.2336	0.2336
492	5TH OF 7 SOLIDS	1/ 0/ 0/11/2/0	CLEAR	0.9434	0.8475	0.7692	0.7266	0.6757	0.4425	0.3448	0.2183	0.2183	0.2183
492	6TH OF 7 SOLIDS	1/ 2/ 2/ 1/2/0	CLEAR	0.8065	0.8475	0.7576	0.6757	0.6667	0.4237	0.3448	0.2183	0.2183	0.2183
492	7TH OF 7 SOLIDS	2/ 7/15/ 0/3/0	CLEAR	0.8333	0.8621	0.7266	0.6944	0.5814	0.4902	0.3876	0.3030	0.2183	0.2183
761	1ST OF 7 SOLIDS	1/ 3/ 4/ 1/2/0	12.240	0.0000	0.0000	0.0000	0.0000	0.0000	0.0000	0.0000	0.0000	0.0000	0.0000
761	2ND OF 7 SOLIDS	1/ 1/ 2/ 1/2/0	12.050	0.0000	0.0000	0.0000	0.0000	0.0000	0.0000	0.0000	0.0000	0.0000	0.0000
761	3RD OF 7 SOLIDS	1/ 2/ 4/ 1/2/0	13.570	0.0000	0.0000	0.0000	0.0000	0.0000	0.0000	0.0000	0.0000	0.0000	0.0000
761	4TH OF 7 SOLIDS	1/ 7/ 8/ 1/2/0	9.430	0.0000	0.0000	0.0000	0.0000	0.0000	0.3165	0.0000	0.0000	0.0000	0.0000
761	5TH OF 7 SOLIDS	2/11/14/ 4/3/3	9.290	0.0000	0.0000	0.0000	0.0000	0.0000	0.3049	0.0000	0.0000	0.0000	0.0000
761	6TH OF 7 SOLIDS	2/13/14/ 0/3/0	9.120	0.0000	0.0000	0.0000	0.0000	0.3356	0.2841	0.0000	0.0000	0.0000	0.0000
761	7TH OF 7 SOLIDS	2/ 7/14/ 0/3/0	8.250	0.8065	0.8333	0.6250	0.4505	0.2252	0.0000	0.0000	0.0000	0.0000	0.0000
762	1ST OF 7 SOLIDS	1/ 5/ 4/ 1/2/0	CLEAR	0.0000	0.0000	0.0000	0.0000	0.0000	0.0000	0.0000	0.0000	0.0000	0.0000
762	2ND OF 7 SOLIDS	1/ 1/ 2/ 1/2/0	CLEAR	0.0000	0.0000	0.0000	0.0000	0.0000	0.0000	0.0000	0.0000	0.0000	0.0000
762	3RD OF 7 SOLIDS	1/ 2/ 4/ 1/2/0	CLEAR	0.0000	0.0000	0.0000	0.0000	0.0000	0.0000	0.0000	0.0000	0.0000	0.0000
762	4TH OF 7 SOLIDS	1/ 7/ 8/ 1/2/0	11.730	0.0000	0.0000	0.0000	0.0000	0.0000	0.0000	0.0000	0.4762	0.0000	0.0000
762	5TH OF 7 SOLIDS	2/11/14/ 4/3/3	11.590	0.0000	0.0000	0.0000	0.0000	0.0000	0.0000	0.0000	0.4762	0.0000	0.0000
762	6TH OF 7 SOLIDS	2/13/14/ 0/3/0	11.350	0.0000	0.0000	0.0000	0.0000	0.0000	0.0000	0.0000	0.4762	0.0000	0.0000
762	7TH OF 7 SOLIDS	2/ 7/14/ 0/3/0	11.070	0.0000	0.0000	0.0000	0.0000	0.0000	0.0000	0.0000	0.4762	0.0000	0.0000
764	1ST OF 7 SOLIDS	1/ 7/ 8/ 1/2/0	11.870	0.0000	0.0000	0.0000	0.0000	0.0000	0.0000	0.0000	0.0000	0.0000	0.0000
764	2ND OF 7 SOLIDS	2/11/14/ 4/3/3	11.730	0.0000	0.0000	0.0000	0.0000	0.0000	0.0000	0.0000	0.0000	0.0000	0.0000
764	3RD OF 7 SOLIDS	2/13/14/ 0/3/0	11.620	0.0000	0.0000	0.0000	0.0000	0.0000	0.0000	0.0000	0.0000	0.0000	0.0000
764	4TH OF 7 SOLIDS	2/ 7/14/ 0/3/0	11.510	0.0000	0.0000	0.0000	0.0000	0.0000	0.0000	0.0000	0.0000	0.0000	0.0000
764	5TH OF 7 SOLIDS	2/ 7/14/ 0/3/0	11.420	0.0000	0.0000	0.0000	0.0000	0.0000	0.0000	0.0000	0.0000	0.0000	0.0000
764	6TH OF 7 SOLIDS	2/ 9/14/ 0/3/0	11.270	1.0204	1.0870	0.8475	0.8065	0.8065	0.6944	0.6667	0.4950	0.0000	0.0000
764	7TH OF 7 SOLIDS	2/ 9/14/ 0/3/0	11.120	0.9091	0.9804	0.9259	0.7813	0.7143	0.6869	0.6667	0.4950	0.0000	0.0000
766	1ST OF 7 SOLIDS	6/ 0/ 0/ 0/0/0	CLEAR	0.0000	0.0000	0.0000	0.0000	0.0000	0.0000	0.0000	0.0000	0.3448	0.3448
766	2ND OF 7 SOLIDS	6/ 0/ 0/ 0/0/0	CLEAR	0.0000	0.0000	0.0000	0.0000	0.0000	0.0000	0.0000	0.0000	0.3226	0.3226
766	3RD OF 7 SOLIDS	4/ 0/ 0/31/0/0	CLEAR	0.9804	1.1111	0.7353	0.6944	0.6944	0.7042	0.6667	0.4902	0.3067	0.3067
766	4TH OF 7 SOLIDS	6/ 0/ 0/ 0/0/0	CLEAR	0.8197	0.9434	0.8065	0.7692	0.7353	0.7692	0.6579	0.4808	0.3030	0.3030
766	5TH OF 7 SOLIDS	2/ 5/14/ 0/3/0	CLEAR	0.8333	0.8621	0.8065	0.7143	0.6329	0.5495	0.3788	0.2874	0.2315	0.2315
766	6TH OF 7 SOLIDS	2/11/14/ 0/3/0	CLEAR	0.8333	0.8621	0.7813	0.6869	0.6024	0.4902	0.3268	0.2841	0.2306	0.2306
766	7TH OF 7 SOLIDS	2/ 5/14/ 0/3/0	CLEAR	0.7576	0.8197	0.7463	0.6667	0.5882	0.4545	0.2959	0.2618	0.2174	0.2174
828	1ST OF 7 SOLIDS	1/10/ 8/ 1/2/0	CLEAR	0.0000	0.0000	0.0000	0.0000	0.0000	0.0000	0.0000	0.0000	0.4902	0.4902
828	2ND OF 7 SOLIDS	2/ 9/14/ 0/3/0	CLEAR	0.0000	0.0000	0.0000	0.0000	0.0000	0.0000	0.0000	0.0000	0.4587	0.4587
828	3RD OF 7 SOLIDS	1/ 5/ 8/ 1/2/0	CLEAR	1.1628	0.8621	0.7353	0.7353	0.7143	0.6869	0.3788	0.2488	0.3012	0.3012
828	4TH OF 7 SOLIDS	1/ 0/ 0/13/2/0	CLEAR	1.1628	0.9091	0.7042	0.6944	0.6944	0.6173	0.3497	0.2488	0.2488	0.2488
828	5TH OF 7 SOLIDS	2/ 7/14/ 0/3/0	8.840	0.8065	0.7937	0.6410	0.5051	0.3289	0.0000	0.0000	0.0000	0.0000	0.0000
828	6TH OF 7 SOLIDS	2/ 7/14/ 0/3/0	8.670	0.7937	0.7937	0.6024	0.4673	0.3289	0.0000	0.0000	0.0000	0.0000	0.0000
828	7TH OF 7 SOLIDS	2/10/14/ 0/3/0	5.420	0.5263	0.3623	0.0000	0.0000	0.0000	0.0000	0.0000	0.0000	0.0000	0.0000
760	1ST OF 8 SOLIDS	1/ 2/ 4/ 1/2/0	CLEAR	0.7813	0.7042	0.6250	0.6173	0.5556	0.5682	0.3759	0.1961	0.0853	0.0853
760	2ND OF 8 SOLIDS	1/ 2/ 4/ 1/2/0	CLEAR	0.7463	0.7353	0.6250	0.5747	0.3817	0.6098	0.4132	0.1901	0.0846	0.0846
760	3RD OF 8 SOLIDS	1/ 3/ 4/ 1/2/0	12.070	0.7463	0.7246	0.6098	0.5435	0.2994	0.7463	0.4098	0.1938	0.0797	0.0797
760	4TH OF 8 SOLIDS	1/ 1/ 2/ 1/2/0	8.950	0.8065	0.8197	0.5952	0.5000	0.2703	0.0000	0.0000	0.0000	0.0000	0.0000
760	5TH OF 8 SOLIDS	1/ 2/ 4/ 1/2/0	8.150	0.8197	0.7692	0.6067	0.5747	0.2604	0.0000	0.0000	0.0000	0.0000	0.0000

760	6TH OF 8 SOLIDS	1/ 7/ 8/ 1/2/0	7.640	0.7463	0.8065	0.6250	0.4762	0.0000	0.0000	0.0000	0.0000	0.0000	0.0000	0.0000	0.0000
760	7TH OF 8 SOLIDS	2/11/14/ 4/3/3	7.500	0.7246	0.8197	0.6024	0.3788	0.0000	0.0000	0.0000	0.0000	0.0000	0.0000	0.0000	0.0000
760	8TH OF 8 SOLIDS	2/13/14/ 0/3/0	7.000	0.7576	0.7692	0.5263	0.0000	0.0000	0.0000	0.0000	0.0000	0.0000	0.0000	0.0000	0.0000
867	1ST OF 8 SOLIDS	1/ 5/ 8/ 1/2/0	11.890	0.0000	0.0000	0.0000	0.0000	0.0000	0.0000	0.0000	0.0000	0.0000	0.0000	0.0000	0.0000
867	2ND OF 8 SOLIDS	2/ 7/14/ 0/3/0	11.840	0.0000	0.0000	0.0000	0.0000	0.0000	0.0000	0.0000	0.0000	0.0000	0.0000	0.0000	0.0000
867	3RD OF 8 SOLIDS	1/ 2/ 4/ 1/2/0	10.510	1.1628	0.9434	0.8772	0.6410	0.5102	0.4348	0.3876	0.0000	0.0000	0.0000	0.0000	0.0000
867	4TH OF 8 SOLIDS	1/ 3/ 8/ 1/2/0	8.150	1.1628	0.9615	0.8929	0.6494	0.4167	0.0000	0.0000	0.0000	0.0000	0.0000	0.0000	0.0000
867	5TH OF 8 SOLIDS	2/ 6/14/ 0/3/0	8.100	0.8333	0.7813	0.7463	0.5747	0.1208	0.0000	0.0000	0.0000	0.0000	0.0000	0.0000	0.0000
867	6TH OF 8 SOLIDS	2/ 6/14/ 0/3/0	7.960	0.7463	0.8197	0.6250	0.4274	0.0000	0.0000	0.0000	0.0000	0.0000	0.0000	0.0000	0.0000
867	7TH OF 8 SOLIDS	2/ 7/14/ 0/3/0	7.580	0.7353	0.7143	0.5155	0.3425	0.0000	0.0000	0.0000	0.0000	0.0000	0.0000	0.0000	0.0000
867	8TH OF 8 SOLIDS	2/ 6/14/ 0/3/0	7.450	0.7042	0.6494	0.4673	0.2591	0.0000	0.0000	0.0000	0.0000	0.0000	0.0000	0.0000	0.0000
868	1ST OF 9 SOLIDS	1/ 3/ 8/ 1/2/0	CLEAR	0.0000	0.0000	0.0000	0.0000	0.0000	0.0000	0.0000	0.0000	0.0000	0.0000	0.0000	0.0000
868	2ND OF 9 SOLIDS	2/ 7/14/ 0/3/0	CLEAR	0.0000	0.0000	0.0000	0.0000	0.0000	0.0000	0.0000	0.0000	0.0000	0.0000	0.0000	0.0000
868	3RD OF 9 SOLIDS	1/ 2/ 4/ 1/2/0	CLEAR	0.0000	0.0000	0.0000	0.0000	0.0000	0.0000	0.0000	0.0000	0.0000	0.0000	0.0000	0.0000
868	4TH OF 9 SOLIDS	1/ 3/ 8/ 1/2/0	CLEAR	0.0000	0.0000	0.0000	0.0000	0.0000	0.0000	0.0000	0.0000	0.0000	0.0000	0.0000	0.0000
868	5TH OF 9 SOLIDS	2/ 6/14/ 0/3/0	CLEAR	0.0000	0.0000	0.0000	0.0000	0.0000	0.0000	0.0000	0.0000	0.0000	0.0000	0.0000	0.0000
868	6TH OF 9 SOLIDS	2/ 6/14/ 0/3/0	CLEAR	0.0000	0.0000	0.0000	0.0000	0.0000	0.0000	0.0000	0.0000	0.0000	0.0000	0.0000	0.0000
868	7TH OF 9 SOLIDS	2/ 7/14/ 0/3/0	CLEAR	0.0000	0.0000	0.0000	0.0000	0.0000	0.0000	0.0000	0.0000	0.0000	0.0000	0.0000	0.0000
868	8TH OF 9 SOLIDS	2/ 6/14/ 0/3/0	CLEAR	0.0000	0.0000	0.0000	0.0000	0.0000	0.0000	0.0000	0.0000	0.0000	0.0000	0.0000	0.0000
868	9TH OF 9 SOLIDS	2/ 5/14/ 0/3/0	CLEAR	0.7937	0.7937	0.6944	0.5747	0.3817	0.3650	0.3106	0.2732	0.2326	0.1910	0.1495	0.1080

COMPUTER CHECK NO. 2600

GREENWICH DISTRICT HOSPITAL, UN SITE
MONITORING OF ABOVE GROUND DRAINAGE.
DR. J.A. SWAFFIELD AND MR. S.D. BOKCR.
DRAINAGE RESEARCH GROUP, - DEPARTMENT OF
BUILDING TECHNOLOGY - BRUNEL UNIVERSITY.

RED W.C. GRADIENT = 1:150.
MALE SUITE OF W.C. S.

NUMBER OF RUNS UNDER COMPARISON = 423 .

VELOCITY MEASURING POINT.
DISTANCE (M) FROM W.C.
SENSOR SEPARATION (M) .

RUN NO. RELATIVE PUSH: SOLID IN FLUSH. CLASSIFICATION STOP POSN.

VELOCITY, M/S.

Run No.	Relative Push: Solid in Flush	Classification	Stop Posn.	1	2	3	4	5	6	7	8	9
19	NO OTHER SOLID	2/ 5/14/ 0/3/0	CLEAR	1.5152	1.2500	1.0870	1.0417	0.9615	0.8197	0.8197	0.8197	0.8197
22	NO OTHER SOLID	2/ 5/14/ 0/3/0	CLEAR	1.2821	1.2500	1.1111	1.0870	0.8065	0.9434	0.7143	0.8333	0.7813
38	NO OTHER SOLID	1/ 0/ 0/ 4/1/0	CLEAR	1.3889	1.3514	1.0870	1.1364	1.1364	0.9259	0.7813	0.6579	0.6098
41	NO OTHER SOLID	2/ 9/13/ 0/3/0	CLEAR	1.4706	1.2500	1.1111	0.9615	0.8197	0.8333	0.6944	0.7353	0.7143
42	NO OTHER SOLID	2/ 9/15/ 0/3/0	CLEAR	1.5152	1.2821	1.0417	1.0417	0.9615	0.8929	0.7353	0.7353	0.7143
47	NO OTHER SOLID	7/13/13/30/1/0	CLEAR	1.0000	1.0417	0.9615	0.9259	0.9259	0.9091	0.6849	0.7937	0.5952
67	NO OTHER SOLID	5/ 5/14/22/3/3	CLEAR	1.0638	1.0204	1.0417	0.9804	0.9434	0.8929	0.8475	0.8929	0.8065
82	NO OTHER SOLID	2/ 9/15/ 0/3/0	8.935	1.4706	1.1628	1.0417	0.8621	0.6667	0.4425	0.2551	0.0000	0.0000
83	NO OTHER SOLID	2/ 9/15/ 0/3/0	CLEAR	0.0000	0.0000	0.0000	0.0000	0.0000	0.0000	0.0000	0.0000	0.6494
96	NO OTHER SOLID	2/ 4/14/ 0/3/0	CLEAR	1.3158	1.0417	1.2821	1.0870	1.1628	1.0204	0.8197	0.7937	0.8065
98	NO OTHER SOLID	2/ 9/14/ 0/3/0	CLEAR	1.2821	1.2195	1.0000	0.8197	0.8333	0.7813	0.5682	0.6173	0.5376
106	NO OTHER SOLID	2/ 7/14/ 0/3/0	10.665	1.3889	1.1628	0.9615	0.8475	0.7937	0.8065	0.6849	0.5747	0.0000
124	NO OTHER SOLID	2/11/14/ 0/3/0	CLEAR	1.4706	1.3158	1.1364	1.0000	0.9259	0.8929	0.7062	0.7246	0.7143
130	NO OTHER SOLID	2/15/12/ 0/3/0	CLEAR	1.5625	1.2821	1.0204	0.9091	0.9804	1.0204	0.7937	0.7692	0.7246
146	NO OTHER SOLID	5/ 9/14/ 0/3/6	CLEAR	1.7241	1.6129	1.3889	1.2500	1.2195	0.8929	0.7062	0.7576	0.8333
157	NO OTHER SOLID	5/ 7/14/21/3/2	CLEAR	1.4286	1.2195	1.0638	0.8929	0.7937	0.7937	0.6329	0.5814	0.5618
213	NO OTHER SOLID	5/ 7/14/30/3/3	10.795	0.0000	0.0000	0.0000	0.0000	0.9615	0.9259	0.6329	0.4098	0.1984
216	NO OTHER SOLID	9/ 7/15/ 0/3/0	10.805	0.0000	0.0000	0.0000	0.0000	0.0000	0.8065	0.5952	0.3906	0.1667
323	NO OTHER SOLID	2/ 9/13/ 0/3/0	CLEAR	1.5625	1.2500	1.1111	0.9615	0.9434	0.9091	0.7692	0.7353	0.6849
330	NO OTHER SOLID	2/13/13/ 0/3/0	CLEAR	1.2821	1.1628	1.0417	0.9434	0.8333	0.7937	0.5000	0.5155	0.4065
334	NO OTHER SOLID	2/ 9/14/ 0/3/0	CLEAR	0.8772	0.8929	0.9091	0.8197	0.8197	0.7692	0.5000	0.5208	0.5263

174	1ST OF 2 SOLIDS	2/11/13/ 0/5/0	5.955	1.2821	1.4286	0.8333	0.0613	0.0000	0.0000	0.0000	0.0000	0.0000	0.0000	0.0000	0.0000	0.0000	0.0000	0.0000	0.0000
174	2ND OF 2 SOLIDS	2/12/14/ 0/4/0	5.535	1.2821	1.3158	0.7937	0.0000	0.0000	0.0000	0.0000	0.0000	0.0000	0.0000	0.0000	0.0000	0.0000	0.0000	0.0000	0.0000
175	1ST OF 2 SOLIDS	2/11/13/ 0/3/0	8.725	0.0000	0.0000	0.0000	0.0000	0.0000	0.0000	0.2075	0.1629	0.0000	0.0000	0.0000	0.0000	0.0000	0.0000	0.0000	0.0000
175	2ND OF 2 SOLIDS	2/12/14/ 0/4/0	8.515	0.0000	0.0000	0.0000	0.0000	0.0000	0.1639	0.2252	0.1211	0.0000	0.0000	0.0000	0.0000	0.0000	0.0000	0.0000	0.0000
186	1ST OF 2 SOLIDS	2/ 7/14/ 0/5/0	CLEAR	1.4706	1.2821	1.1628	1.0000	0.9091	0.7042	0.8065	0.8475	0.3937	0.8621	0.8621	0.8621	0.8621	0.8621	0.8621	0.8621
186	2ND OF 2 SOLIDS	2/10/13/ 0/3/0	CLEAR	1.5025	1.3158	1.1628	0.8475	0.8475	0.7042	0.6410	0.3937	0.3937	0.3937	0.3937	0.3937	0.3937	0.3937	0.3937	0.3937
189	1ST OF 2 SOLIDS	7/16/13/ 0/1/0	CLEAR	1.3214	1.1905	0.9615	0.9091	0.9434	0.0000	0.8929	0.8475	0.5747	0.8475	0.8475	0.8475	0.8475	0.8475	0.8475	0.8475
189	2ND OF 2 SOLIDS	2/ 9/14/ 0/5/0	6.315	1.3889	0.9804	0.7353	0.4032	0.0000	0.0000	0.0000	0.0000	0.0000	0.0000	0.0000	0.0000	0.0000	0.0000	0.0000	0.0000
199	1ST OF 2 SOLIDS	0/ 0/ 0/ 0/0/0	CLEAR	0.0000	0.0000	0.0000	0.0000	0.0000	0.0000	0.0000	0.0000	0.0000	0.0000	0.0000	0.0000	0.0000	0.0000	0.0000	0.0000
199	2ND OF 2 SOLIDS	2/ 7/13/ 0/5/0	CLEAR	0.0000	0.0000	0.0000	0.0000	0.0000	0.0000	0.0000	0.0000	0.0000	0.0000	0.0000	0.0000	0.0000	0.0000	0.0000	0.0000
201	1ST OF 2 SOLIDS	2/ 7/15/ 0/5/0	CLEAR	1.2500	0.9615	0.9804	0.8621	0.7463	0.8197	0.8333	0.5814	0.5814	0.5814	0.5814	0.5814	0.5814	0.5814	0.5814	0.5814
201	2ND OF 2 SOLIDS	2/ 5/14/ 0/3/0	CLEAR	1.4286	1.0870	0.9434	0.8929	0.8197	0.8197	0.7576	0.5102	0.4274	0.4274	0.4274	0.4274	0.4274	0.4274	0.4274	0.4274
210	1ST OF 2 SOLIDS	1/ 2/ 4/ 1/1/0	CLEAR	1.3214	1.3889	1.0638	1.1628	0.9615	1.1628	1.1905	0.8475	0.7246	0.7246	0.7246	0.7246	0.7246	0.7246	0.7246	0.7246
210	2ND OF 2 SOLIDS	1/ 2/ 4/ 1/1/0	CLEAR	1.5025	1.4706	1.1628	1.1111	1.0204	1.0204	1.0417	0.7937	0.6757	0.6757	0.6757	0.6757	0.6757	0.6757	0.6757	0.6757
246	1ST OF 2 SOLIDS	2/11/14/ 0/3/6	CLEAR	1.1905	1.2500	1.0000	0.8197	0.8333	0.3597	0.9259	0.7143	0.5952	0.5952	0.5952	0.5952	0.5952	0.5952	0.5952	0.5952
246	2ND OF 2 SOLIDS	2/13/14/ 0/5/0	7.815	1.4706	1.2195	0.9615	0.6757	0.3597	0.3597	0.1087	0.0000	0.0000	0.0000	0.0000	0.0000	0.0000	0.0000	0.0000	0.0000
259	1ST OF 2 SOLIDS	7/16/16/ 0/1/0	CLEAR	1.7241	1.1628	1.2195	1.0417	1.1628	1.1628	1.0204	0.8065	0.9259	0.9259	0.9259	0.9259	0.9259	0.9259	0.9259	0.9259
259	2ND OF 2 SOLIDS	0/ 0/ 0/ 0/0/0	5.815	1.2821	1.0870	0.8065	0.6024	0.0000	0.0000	0.0000	0.0000	0.0000	0.0000	0.0000	0.0000	0.0000	0.0000	0.0000	0.0000
266	1ST OF 2 SOLIDS	2/ 5/14/ 0/3/0	CLEAR	1.4286	1.1905	1.1364	1.0870	1.0417	1.0417	1.0638	1.0204	0.9091	0.9091	0.9091	0.9091	0.9091	0.9091	0.9091	0.9091
266	2ND OF 2 SOLIDS	7/16/16/ 0/1/0	CLEAR	1.3889	1.1905	1.1111	1.0417	1.0417	1.0417	0.9259	0.8929	0.7576	0.7576	0.7576	0.7576	0.7576	0.7576	0.7576	0.7576
272	1ST OF 2 SOLIDS	2/ 9/15/ 0/3/0	CLEAR	1.4706	1.0870	1.1628	0.8772	0.8929	0.8929	0.8621	0.6250	0.6757	0.6757	0.6757	0.6757	0.6757	0.6757	0.6757	0.6757
272	2ND OF 2 SOLIDS	2/ 5/15/ 0/3/0	CLEAR	1.5152	1.3158	1.1905	0.9434	0.8475	0.8475	0.8475	0.6410	0.6579	0.6579	0.6579	0.6579	0.6579	0.6579	0.6579	0.6579
318	1ST OF 2 SOLIDS	2/ 9/14/ 0/3/6	CLEAR	1.3214	1.1364	1.0000	1.0000	0.9615	1.0000	1.0000	0.8621	0.8333	0.8333	0.8333	0.8333	0.8333	0.8333	0.8333	0.8333
318	2ND OF 2 SOLIDS	2/11/14/ 0/3/0	CLEAR	1.5025	1.3514	1.2195	1.0870	1.0417	1.0417	0.9804	0.6849	0.6579	0.6579	0.6579	0.6579	0.6579	0.6579	0.6579	0.6579
335	1ST OF 2 SOLIDS	2/ 3/12/ 0/3/0	CLEAR	1.3889	1.1628	1.0000	0.9434	0.8475	0.8475	0.7576	0.5952	0.6094	0.6094	0.6094	0.6094	0.6094	0.6094	0.6094	0.6094
335	2ND OF 2 SOLIDS	2/ 3/12/ 0/3/0	CLEAR	1.0638	0.9259	1.0204	0.8475	0.7042	0.7042	0.5618	0.4630	0.4762	0.4762	0.4762	0.4762	0.4762	0.4762	0.4762	0.4762
340	1ST OF 2 SOLIDS	2/ 9/14/ 0/5/0	CLEAR	1.5025	1.2821	1.0870	0.9804	0.9615	0.8621	0.8333	0.6494	0.5376	0.5376	0.5376	0.5376	0.5376	0.5376	0.5376	0.5376
340	2ND OF 2 SOLIDS	2/ 7/14/ 0/5/0	CLEAR	1.4286	1.1905	1.0417	0.9804	0.8621	0.8621	0.7937	0.5882	0.4505	0.4505	0.4505	0.4505	0.4505	0.4505	0.4505	0.4505
344	1ST OF 2 SOLIDS	0/11/14/ 0/3/0	9.225	1.3889	1.1905	1.0000	0.9259	0.7353	0.7353	0.7042	0.3597	0.0000	0.0000	0.0000	0.0000	0.0000	0.0000	0.0000	0.0000
344	2ND OF 2 SOLIDS	0/11/14/ 0/3/0	8.815	1.3889	1.1628	0.9434	0.8475	0.7463	0.7463	0.6098	0.2566	0.0000	0.0000	0.0000	0.0000	0.0000	0.0000	0.0000	0.0000
387	1ST OF 2 SOLIDS	2/13/14/22/3/3	CLEAR	1.3214	1.1905	1.1628	1.1111	1.0204	1.0204	0.9804	0.7937	0.7937	0.7937	0.7937	0.7937	0.7937	0.7937	0.7937	0.7937
387	2ND OF 2 SOLIDS	2/ 7/14/ 0/5/0	CLEAR	1.4286	1.2821	1.1111	0.8621	0.8197	0.8197	0.8197	0.6329	0.6329	0.6329	0.6329	0.6329	0.6329	0.6329	0.6329	0.6329
396	1ST OF 2 SOLIDS	2/10/14/ 0/3/0	CLEAR	1.4286	1.2195	1.0000	0.8475	0.9434	0.8929	0.5682	0.5376	0.4950	0.4950	0.4950	0.4950	0.4950	0.4950	0.4950	0.4950
396	2ND OF 2 SOLIDS	2/ 7/14/ 0/3/0	CLEAR	1.3158	1.2195	1.0417	0.8197	0.7246	0.7246	0.6329	0.3788	0.4065	0.4065	0.4065	0.4065	0.4065	0.4065	0.4065	0.4065
402	1ST OF 2 SOLIDS	2/11/14/25/5/3	CLEAR	1.4286	1.3514	1.2500	1.1628	1.1364	1.1364	0.9434	0.7246	0.5952	0.5952	0.5952	0.5952	0.5952	0.5952	0.5952	0.5952
402	2ND OF 2 SOLIDS	5/13/14/30/5/3	CLEAR	1.3889	1.2500	1.1905	1.0638	0.9804	0.9804	0.8621	0.5882	0.2825	0.2825	0.2825	0.2825	0.2825	0.2825	0.2825	0.2825
410	1ST OF 2 SOLIDS	1/ 0/ 0/30/1/0	CLEAR	1.4706	1.1111	0.9434	1.1628	1.2500	0.9259	0.8621	1.0000	0.8197	1.0000	0.8197	1.0000	0.8197	1.0000	0.8197	1.0000
410	2ND OF 2 SOLIDS	2/11/14/ 0/3/0	2.855	0.4202	0.0000	0.0000	0.0000	0.0000	0.0000	0.0000	0.0000	0.0000	0.0000	0.0000	0.0000	0.0000	0.0000	0.0000	0.0000
412	1ST OF 2 SOLIDS	1/ 0/ 0/11/1/0	CLEAR	1.3889	1.1628	1.0870	1.3158	0.9615	1.1628	1.1628	0.8621	0.9615	0.7246	0.7246	0.7246	0.7246	0.7246	0.7246	0.7246
412	2ND OF 2 SOLIDS	2/ 5/14/ 0/3/0	CLEAR	1.4286	1.2500	1.0638	0.9259	0.7937	0.7937	0.7042	0.5319	0.5155	0.5155	0.5155	0.5155	0.5155	0.5155	0.5155	0.5155
419	1ST OF 2 SOLIDS	2/ 9/16/ 0/3/0	8.655	1.3889	1.1905	1.1364	0.9615	0.7576	0.7576	0.4717	0.0000	0.0000	0.0000	0.0000	0.0000	0.0000	0.0000	0.0000	0.0000
419	2ND OF 2 SOLIDS	2/ 9/16/ 0/3/0	7.895	1.5152	1.1905	1.0870	0.7937	0.6024	0.6024	0.3906	0.0000	0.0000	0.0000	0.0000	0.0000	0.0000	0.0000	0.0000	0.0000
420	1ST OF 2 SOLIDS	2/ 2/16/ 0/3/0	CLEAR	0.0000	0.0000	0.0000	0.0000	0.0000	0.0000	0.0000	0.0000	0.0000	0.0000	0.0000	0.0000	0.0000	0.0000	0.0000	0.0000
420	2ND OF 2 SOLIDS	2/ 9/16/ 0/3/0	CLEAR	0.0000	0.0000	0.0000	0.0000	0.0000	0.0000	0.0000	0.0000	0.0000	0.0000	0.0000	0.0000	0.0000	0.0000	0.0000	0.0000

100

299	1ST OF 3 SOLIDS	1/ 0/ 0/30/1/0	CLEAR	1.2621	1.1111	1.0638	0.9434	0.8929	0.9615	0.7353	0.7143	0.6250
299	2ND OF 3 SOLIDS	5/13/14/21/3/3	9.225	1.3689	1.0870	0.9615	0.8621	0.7463	0.6494	0.3846	0.0000	0.0000
299	3RD OF 3 SOLIDS	2/ 7/14/ 0/3/0	7.835	1.1905	0.9432	0.8475	0.6173	0.4762	0.2451	0.0000	0.0000	0.0000
325	1ST OF 3 SOLIDS	2/ 7/14/ 0/3/0	CLEAR	0.0000	0.0000	0.0000	0.0000	0.0000	0.8929	0.8333	0.7813	0.7692
325	2ND OF 3 SOLIDS	2/ 7/14/ 0/3/0	CLEAR	0.0000	0.0000	0.0000	0.0000	0.0000	0.9091	0.7813	0.7576	0.7463
325	3RD OF 3 SOLIDS	2/ 9/14/ 0/3/0	CLEAR	0.0000	0.0000	0.0000	0.0000	0.7246	0.8772	0.7813	0.7463	0.5208
360	1ST OF 3 SOLIDS	1/ 3/ 6/ 1/1/0	CLEAR	1.2821	1.0417	0.9615	1.0417	1.0000	0.8621	0.8065	0.8333	0.8333
360	2ND OF 3 SOLIDS	7/13/16/ 0/1/0	CLEAR	1.1111	1.0638	0.9804	0.8475	0.8772	0.8621	0.7463	0.8197	0.7246
360	3RD OF 3 SOLIDS	2/ 9/14/ 0/3/0	CLEAR	1.5152	1.2195	1.0204	0.8197	0.6757	0.5356	0.2793	0.0336	0.0906
418	1ST OF 3 SOLIDS	1/ 0/ 0/11/1/0	CLEAR	1.4706	1.2195	1.1364	1.2821	1.0870	1.0870	0.8621	0.6494	0.7937
418	2ND OF 3 SOLIDS	2/ 4/14/ 0/3/0	CLEAR	1.4706	1.2821	1.0638	0.9434	0.9434	0.8929	0.6869	0.5747	0.5556
418	3RD OF 3 SOLIDS	2/ 5/14/ 0/3/0	CLEAR	0.9434	0.7576	0.7813	0.7937	0.5952	0.2976	0.1923	0.1553	0.2075
473	1ST OF 3 SOLIDS	2/ 7/14/ 0/3/0	CLEAR	1.3158	1.2195	1.1111	1.0417	0.9091	0.8333	0.7813	0.7813	0.7937
473	2ND OF 3 SOLIDS	2/ 7/14/ 0/3/0	CLEAR	1.4286	1.2195	1.0204	0.9091	0.9259	0.9259	0.7576	0.6944	0.6757
473	3RD OF 3 SOLIDS	2/ 7/14/ 0/3/0	CLEAR	1.4286	1.1111	0.9434	0.9259	0.9259	0.8772	0.7266	0.6944	0.6579
476	1ST OF 3 SOLIDS	2/11/16/ 1/4/0	CLEAR	0.0000	0.0000	1.0417	0.9259	1.1628	0.8475	0.7353	0.7576	0.6849
476	2ND OF 3 SOLIDS	2/11/15/ 0/5/0	CLEAR	1.2821	1.1364	1.0204	0.9091	0.8333	0.7692	0.6173	0.5814	0.4587
476	3RD OF 3 SOLIDS	2/11/14/ 0/3/0	8.645	1.3158	1.0417	0.7937	0.5556	0.4386	0.2439	0.0000	0.0000	0.0000
479	1ST OF 3 SOLIDS	2/ 9/14/ 0/3/0	CLEAR	1.5152	1.1905	1.0204	0.9259	0.8197	0.9091	0.6173	0.6024	0.5882
479	2ND OF 3 SOLIDS	1/ 0/ 0/30/2/0	CLEAR	1.3689	1.1364	0.9434	0.8065	0.8475	0.7143	0.5695	0.4630	0.3968
479	3RD OF 3 SOLIDS	2/ 9/14/ 0/3/0	CLEAR	1.2500	1.2500	1.0638	0.8621	0.7463	0.7353	0.4902	0.4425	0.4202
488	1ST OF 3 SOLIDS	1/ 6/ 4/ 1/1/0	CLEAR	1.4286	1.1628	1.0870	1.0000	0.9615	0.8929	0.6757	0.5682	0.5319
488	2ND OF 3 SOLIDS	2/ 9/14/ 0/3/0	CLEAR	1.5025	1.3889	1.2195	1.0000	0.8475	0.8197	0.6173	0.5747	0.5208
488	3RD OF 3 SOLIDS	2/ 5/14/ 0/3/0	CLEAR	1.4286	1.1111	1.0000	0.7353	0.6579	0.5814	0.3817	0.3876	0.4237
5	1ST OF 4 SOLIDS	1/ 4/ 8/ 1/2/0	CLEAR	0.0000	0.0000	0.0000	0.0000	0.0000	0.0000	0.0000	0.7576	0.6494
5	2ND OF 4 SOLIDS	2/ 5/16/ 0/3/0	CLEAR	0.0000	0.0000	0.0000	0.0000	0.0000	0.0000	0.0000	0.7576	0.6494
5	3RD OF 4 SOLIDS	2/ 4/13/ 0/3/0	10.615	1.2195	0.8333	1.0417	1.1364	1.1111	1.0204	0.7463	0.6410	0.0000
5	4TH OF 4 SOLIDS	1/ 7/ 8/ 1/2/0	10.555	1.3514	1.3158	1.0638	1.0417	0.9259	0.8065	0.5814	0.3521	0.0000
15	1ST OF 4 SOLIDS	1/ 0/ 0/11/1/0	CLEAR	1.6067	1.2821	1.1364	1.0417	1.0000	0.9804	0.7813	0.7143	0.7576
15	2ND OF 4 SOLIDS	1/ 5/ 6/ 1/1/0	CLEAR	1.6129	1.2195	1.1111	1.0417	1.0000	0.9804	0.7813	0.6379	0.6410
15	3RD OF 4 SOLIDS	1/ 5/ 6/ 1/1/0	CLEAR	1.6129	1.1364	1.1111	1.0204	0.9259	1.0000	0.7143	0.7042	0.5882
15	4TH OF 4 SOLIDS	1/ 5/ 6/ 1/1/0	CLEAR	1.6129	1.1111	1.0638	0.9615	0.8621	0.8772	0.6757	0.6849	0.5618
58	1ST OF 4 SOLIDS	1/ 3/ 4/ 1/1/0	CLEAR	1.1564	1.6667	1.2195	1.0870	1.0638	0.9615	0.7246	0.7353	0.7042
58	2ND OF 4 SOLIDS	1/ 3/ 4/ 1/1/0	CLEAR	1.1564	1.6667	1.2195	1.0870	1.0638	0.9615	0.7246	0.7353	0.7042
58	3RD OF 4 SOLIDS	1/ 2/ 4/ 1/1/0	CLEAR	1.1564	1.6667	1.2195	1.0870	1.0638	0.9615	0.7246	0.7353	0.7042
58	4TH OF 4 SOLIDS	1/ 4/ 6/ 1/2/0	CLEAR	1.1111	1.4706	1.1364	0.9434	0.8333	0.5495	0.6410	0.5376	0.5208
69	1ST OF 4 SOLIDS	1/ 3/ 5/ 1/1/0	CLEAR	1.4286	1.1111	1.1111	1.0870	1.0870	1.0870	0.7937	0.5882	0.7353
69	2ND OF 4 SOLIDS	1/ 4/ 5/ 1/1/0	CLEAR	1.3514	1.1628	1.1364	1.0417	1.0870	1.0000	0.6579	0.7576	0.7353
69	3RD OF 4 SOLIDS	1/ 4/ 5/ 1/1/0	CLEAR	1.3158	1.1905	1.1364	1.1111	1.0638	1.0000	0.6579	0.5747	0.7692
69	4TH OF 4 SOLIDS	2/ 5/14/ 0/3/0	CLEAR	1.4706	1.3158	1.1111	0.9804	0.8929	0.9259	0.7353	0.7042	0.7143
104	1ST OF 4 SOLIDS	1/ 2/ 2/ 1/2/0	CLEAR	1.3158	1.0638	1.0417	0.9615	0.9259	0.9091	0.6579	0.7042	0.7042
104	2ND OF 4 SOLIDS	1/ 7/ 5/ 1/2/0	CLEAR	1.3158	1.0638	1.0417	0.9615	0.9259	0.9091	0.6579	0.7042	0.7042
104	3RD OF 4 SOLIDS	1/ 5/ 5/ 1/2/0	CLEAR	1.3158	1.0638	1.0417	0.9615	0.9259	0.9091	0.6579	0.7042	0.7042
104	4TH OF 4 SOLIDS	2/ 9/15/ 0/5/0	CLEAR	1.3158	1.1364	1.0617	0.8929	0.7042	0.5155	0.2959	0.2016	0.1969
172	1ST OF 4 SOLIDS	1/ 9/ 8/ 1/2/0	10.895	0.0000	0.0000	0.0000	0.0000	0.0000	0.0000	0.0000	0.0000	0.0000
172	2ND OF 4 SOLIDS	2/ 7/15/ 0/5/0	10.895	0.0000	0.0000	0.0000	0.0000	0.0000	0.0000	0.0000	0.0000	0.0000
172	3RD OF 4 SOLIDS	1/ 2/ 4/ 1/1/0	10.715	1.6667	1.0638	1.1905	1.0204	0.9804	0.9804	0.7266	0.5155	0.0000
172	4TH OF 4 SOLIDS	1/ 2/ 4/ 1/1/0	10.715	1.6667	1.0617	1.1628	1.0000	0.9804	1.0000	0.6757	0.4902	0.0000
229	1ST OF 4 SOLIDS	5/ 9/16/23/5/3	CLEAR	0.0000	0.0000	0.0000	0.0000	0.0000	0.0000	0.0000	0.4673	0.3597
229	2ND OF 4 SOLIDS	1/ 7/ 6/ 1/2/0	CLEAR	1.2500	1.3158	1.0638	0.8929	0.9259	0.8197	0.5747	0.5208	0.3165
229	3RD OF 4 SOLIDS	2/12/14/ 0/5/0	CLEAR	1.1111	1.1905	1.1364	0.8929	0.8197	0.7937	0.5319	0.4587	0.3817
229	4TH OF 4 SOLIDS	2/ 7/14/ 0/5/0	5.915	0.9259	0.7353	0.5556	0.2561	0.0000	0.0000	0.0000	0.0000	0.0000

24	1ST OF 5 SOLIDS	2/ 7/ 14/ 0/ 5/ 0	9.755	1.6667	1.2500	1.0870	1.0417	0.7463	0.5000	0.4808	0.1623	0.0000
24	2ND OF 5 SOLIDS	1/ 4/ 6/ 1/ 2/ 0	9.615	1.5152	1.3514	1.0204	0.9615	0.7246	0.4902	0.4132	0.0000	0.0000
24	3RD OF 5 SOLIDS	1/ 5/ 6/ 1/ 2/ 0	9.615	1.6667	1.2821	1.0417	0.9259	0.7692	0.5000	0.4000	0.0000	0.0000
24	4TH OF 5 SOLIDS	2/ 5/ 14/ 0/ 3/ 0	9.255	1.2821	1.0870	1.0000	0.9091	0.7463	0.5000	0.2907	0.0000	0.0000
24	5TH OF 5 SOLIDS	2/ 5/ 14/ 0/ 3/ 0	9.005	1.2821	1.1628	1.0638	0.8475	0.7042	0.4464	0.2564	0.0000	0.0000
56	1ST OF 5 SOLIDS	1/ 5/ 6/ 1/ 2/ 0	CLEAR	1.0000	1.1111	0.9804	0.9091	1.1364	1.1111	0.7813	0.6173	0.3906
56	2ND OF 5 SOLIDS	1/ 7/ 6/ 1/ 2/ 0	CLEAR	1.0000	1.1111	0.9804	0.9259	1.1111	1.0638	0.7463	0.5051	0.3650
56	3RD OF 5 SOLIDS	1/ 9/ 6/ 1/ 2/ 0	9.145	1.0000	1.1111	0.9804	0.9434	0.8929	0.5495	0.4032	0.0000	0.0000
56	4TH OF 5 SOLIDS	2/ 9/ 13/ 0/ 3/ 0	9.065	1.0000	1.1111	0.9804	0.9434	0.8929	0.5495	0.4032	0.0000	0.0000
56	5TH OF 5 SOLIDS	2/ 9/ 14/ 0/ 3/ 0	8.845	1.0000	1.1111	0.9804	0.9615	0.8333	0.4425	0.2994	0.0000	0.0000
70	1ST OF 5 SOLIDS	1/ 0/ 0/ 25/ 1/ 0	CLEAR	1.3158	1.2500	0.9091	1.0417	0.8475	0.9434	0.9091	0.6757	0.2941
70	2ND OF 5 SOLIDS	1/ 7/ 5/ 1/ 1/ 0	CLEAR	1.1905	1.2195	1.0000	0.9091	0.9091	0.8065	0.7042	0.6024	0.3788
70	3RD OF 5 SOLIDS	2/ 5/ 14/ 0/ 3/ 0	CLEAR	1.3158	1.2500	1.0000	0.9434	0.8772	0.8772	0.6757	0.5814	0.4505
70	4TH OF 5 SOLIDS	2/ 5/ 14/ 0/ 3/ 0	CLEAR	1.3158	1.1905	1.0417	0.9259	0.8333	0.8065	0.4950	0.4505	0.3968
70	5TH OF 5 SOLIDS	1/ 2/ 4/ 1/ 2/ 0	CLEAR	0.9015	0.9259	0.8621	0.8065	0.6250	0.3623	0.2128	0.2427	0.2326
137	1ST OF 5 SOLIDS	1/ 5/ 6/ 1/ 1/ 0	CLEAR	1.3689	1.0870	1.0204	0.9259	1.0870	1.0638	0.7813	0.7937	0.7576
137	2ND OF 5 SOLIDS	1/ 4/ 6/ 1/ 1/ 0	CLEAR	1.1628	1.2821	1.1111	0.9434	1.0638	0.9804	0.6173	0.7813	0.7813
137	3RD OF 5 SOLIDS	1/ 2/ 4/ 1/ 1/ 0	CLEAR	1.3158	0.9804	1.2500	0.9434	1.0417	0.9804	0.6410	0.7576	0.7353
137	4TH OF 5 SOLIDS	1/ 3/ 6/ 1/ 1/ 0	CLEAR	1.2500	1.0638	1.2821	0.9804	1.0204	0.9804	0.5747	0.5051	0.5435
137	5TH OF 5 SOLIDS	2/ 9/ 14/ 0/ 3/ 0	CLEAR	1.6129	1.3158	1.0638	0.9434	0.8929	0.8475	0.6849	0.4902	0.3846
168	1ST OF 5 SOLIDS	1/ 2/ 4/ 1/ 2/ 0	CLEAR	0.0000	0.0000	0.0000	0.0000	0.0000	0.0000	0.0000	0.0000	0.4545
168	2ND OF 5 SOLIDS	5/ 11/ 13/ 0/ 5/ 4	CLEAR	0.0000	0.0000	0.0000	0.0000	0.0000	0.0000	0.0000	0.0000	0.4545
168	3RD OF 5 SOLIDS	2/ 7/ 16/ 0/ 5/ 0	CLEAR	0.0000	0.0000	0.0000	0.0000	0.0000	0.0000	0.0000	0.0000	0.4545
168	4TH OF 5 SOLIDS	1/ 2/ 5/ 1/ 2/ 0	CLEAR	1.2821	1.1628	1.0670	0.9434	0.8475	0.5882	0.3378	0.4673	0.4310
168	5TH OF 5 SOLIDS	1/ 4/ 6/ 1/ 2/ 0	CLEAR	1.2821	1.1628	1.0870	0.9434	0.8475	0.5882	0.3378	0.4673	0.4310
294	1ST OF 5 SOLIDS	1/ 4/ 5/ 1/ 1/ 0	CLEAR	1.1905	1.1364	1.2500	1.1905	1.1364	1.0870	0.8772	0.8475	0.8475
294	2ND OF 5 SOLIDS	1/ 4/ 5/ 1/ 1/ 0	CLEAR	1.2500	1.1364	1.2821	1.1905	1.1364	0.9615	0.9259	0.8475	0.8621
294	3RD OF 5 SOLIDS	1/ 4/ 5/ 1/ 1/ 0	CLEAR	1.1364	1.2500	1.2500	1.1364	1.0417	0.8929	0.8621	0.8333	0.8065
294	4TH OF 5 SOLIDS	1/ 4/ 5/ 1/ 1/ 0	CLEAR	1.2500	1.3158	1.1628	1.0870	1.0204	0.9434	0.8333	0.7937	0.7813
294	5TH OF 5 SOLIDS	2/ 11/ 14/ 0/ 3/ 0	CLEAR	1.2500	1.2500	1.1364	1.0870	1.0204	0.9615	0.8333	0.7937	0.7813
372	1ST OF 5 SOLIDS	1/ 4/ 6/ 1/ 1/ 0	CLEAR	1.3514	1.1905	1.1628	1.2500	1.1628	1.0417	0.7143	0.7692	0.7813
372	2ND OF 5 SOLIDS	7/ 13/ 14/ 0/ 1/ 0	CLEAR	1.3514	1.1905	1.0870	1.0000	0.8772	0.8929	0.7576	0.7246	0.7576
372	3RD OF 5 SOLIDS	1/ 4/ 6/ 1/ 1/ 0	CLEAR	1.3514	1.1628	1.0870	0.9259	0.8621	0.9615	0.6579	0.6667	0.5376
372	4TH OF 5 SOLIDS	7/ 11/ 14/ 0/ 1/ 0	CLEAR	1.3514	1.1628	1.0638	0.9259	0.8621	0.8772	0.6757	0.5435	0.3546
372	5TH OF 5 SOLIDS	1/ 4/ 6/ 1/ 1/ 0	CLEAR	1.3514	1.1628	1.0417	0.9434	0.9091	0.8772	0.6173	0.5435	0.3268
377	1ST OF 5 SOLIDS	1/ 4/ 5/ 1/ 1/ 0	CLEAR	1.3158	1.1364	1.1111	1.0870	1.0638	0.8197	0.6849	0.6173	0.6410
377	2ND OF 5 SOLIDS	1/ 0/ 0/ 21/ 1/ 0	CLEAR	1.3158	1.1364	1.1111	1.0870	1.0638	0.8197	0.6849	0.6173	0.6410
377	3RD OF 5 SOLIDS	1/ 5/ 5/ 1/ 1/ 0	CLEAR	1.3158	1.1364	1.1111	1.0870	1.0638	0.8197	0.6849	0.6173	0.6410
377	4TH OF 5 SOLIDS	1/ 4/ 5/ 1/ 1/ 0	CLEAR	1.3158	1.1364	1.1111	1.0870	1.0638	0.8197	0.6849	0.6173	0.6410
377	5TH OF 5 SOLIDS	2/ 9/ 14/ 0/ 3/ 0	CLEAR	1.3514	1.1364	1.0870	0.8621	0.7937	0.7353	0.4664	0.4673	0.4098
378	1ST OF 5 SOLIDS	1/ 7/ 5/ 1/ 2/ 0	CLEAR	1.6129	1.3158	1.0870	1.0870	0.9434	0.9434	0.7246	0.7813	0.8333
378	2ND OF 5 SOLIDS	1/ 3/ 5/ 1/ 2/ 0	CLEAR	1.6129	1.3158	1.0870	1.0870	0.9804	0.9804	0.7692	0.7937	0.7937
378	3RD OF 5 SOLIDS	1/ 5/ 5/ 1/ 2/ 0	CLEAR	1.6129	1.3158	1.0638	0.9804	0.9091	0.8333	0.5556	0.6098	0.6098
378	4TH OF 5 SOLIDS	2/ 11/ 14/ 0/ 3/ 0	CLEAR	1.6129	1.3158	1.0417	0.8475	0.7937	0.6944	0.3968	0.4425	0.3846
378	5TH OF 5 SOLIDS	2/ 7/ 14/ 0/ 3/ 0	CLEAR	1.5152	1.1364	0.9434	0.8197	0.6667	0.4673	0.3106	0.2381	0.2381
383	1ST OF 5 SOLIDS	1/ 3/ 6/ 1/ 2/ 0	10.255	0.0000	0.0000	0.0000	0.0000	0.0000	0.0000	0.0000	0.1479	0.0000
383	2ND OF 5 SOLIDS	1/ 5/ 8/ 1/ 2/ 0	9.975	0.0000	0.0000	0.0000	0.0000	0.5435	0.5319	0.3356	0.1282	0.0000
383	3RD OF 5 SOLIDS	2/ 5/ 16/ 0/ 5/ 0	9.925	0.0000	0.0000	0.0000	0.0000	0.5435	0.5319	0.3356	0.1282	0.0000
383	4TH OF 5 SOLIDS	1/ 3/ 6/ 1/ 2/ 0	9.865	0.0000	0.0000	0.0000	0.0000	0.5435	0.5319	0.3356	0.1282	0.0000
383	5TH OF 5 SOLIDS	2/ 5/ 14/ 0/ 3/ 0	9.755	0.8929	0.8929	0.8772	0.6250	0.5376	0.1548	0.0000	0.0000	0.0000
417	1ST OF 5 SOLIDS	2/ 13/ 16/ 0/ 5/ 0	CLEAR	0.0000	0.0000	0.0000	0.0000	0.0000	0.0000	0.0000	0.6667	0.6250
417	2ND OF 5 SOLIDS	1/ 0/ 0/ 30/ 1/ 0	CLEAR	1.2195	1.1111	1.3514	1.1111	1.0417	1.1111	0.5051	0.6757	0.5952
417	3RD OF 5 SOLIDS	1/ 4/ 5/ 1/ 1/ 0	CLEAR	1.2195	1.1111	1.3514	1.1111	1.0417	1.1111	0.5051	0.6757	0.5952
417	4TH OF 5 SOLIDS	1/ 0/ 0/ 23/ 1/ 0	CLEAR	1.2195	1.1111	1.3514	1.1111	1.0417	1.1111	0.5051	0.6757	0.5952
417	5TH OF 5 SOLIDS	2/ 5/ 14/ 0/ 3/ 0	CLEAR	1.2195	1.1111	1.3514	1.1111	1.0417	1.1111	0.5051	0.6757	0.5952

490	1ST OF 5 SOLIDS	1/ 0/ 0/22/1/0	CLEAR	1.4706	1.0870	1.1364	1.1628	1.0417	0.8772	0.8621	0.8065	0.7813
490	2ND OF 5 SOLIDS	1/ 5/ 4/ 1/1/0	CLEAR	1.4286	1.2821	1.1111	1.1111	1.0000	1.0204	0.7692	0.8333	0.8621
490	3RD OF 5 SOLIDS	1/ 5/ 4/ 1/1/0	CLEAR	1.4706	1.1628	1.1628	0.9804	0.9091	1.0638	0.8475	0.8065	0.7463
490	4TH OF 5 SOLIDS	2/ 7/14/ 0/3/0	CLEAR	1.2195	1.1905	1.1628	1.0000	0.9091	0.8475	0.5952	0.5747	0.4808
490	5TH OF 5 SOLIDS	2/ 7/14/ 0/3/0	CLEAR	1.5152	1.2500	1.0417	0.9615	0.8475	0.8065	0.5747	0.5682	0.5051
90	1ST OF 6 SOLIDS	1/ 0/ 0/22/1/0	CLEAR	1.5152	1.1905	1.1628	1.0638	0.9091	1.2195	0.7042	0.8197	0.7576
90	2ND OF 6 SOLIDS	1/ 5/ 5/ 1/1/0	CLEAR	1.5152	1.3158	1.2195	1.1628	1.0417	1.0204	0.7937	0.8333	0.7463
90	3RD OF 6 SOLIDS	1/ 2/ 4/ 1/1/0	CLEAR	1.3889	1.3158	1.1628	1.0417	0.9804	0.9091	0.6944	0.7576	0.7353
90	4TH OF 6 SOLIDS	1/ 5/ 5/ 1/1/0	CLEAR	1.5152	1.3158	1.1364	0.9615	1.0000	0.7937	0.7042	0.7353	0.7353
90	5TH OF 6 SOLIDS	1/ 3/ 4/ 1/1/0	CLEAR	1.4286	1.3158	1.1111	1.0000	0.8929	0.8772	0.7692	0.7813	0.7143
90	6TH OF 6 SOLIDS	2/ 5/14/ 0/3/0	CLEAR	1.3158	1.1364	1.0638	0.9091	0.8475	0.7246	0.6762	0.3650	0.2959
92	1ST OF 6 SOLIDS	1/ 0/ 0/12/1/0	CLEAR	1.3158	1.0417	1.0417	0.9259	0.9615	0.9091	0.9091	0.7937	0.8621
92	2ND OF 6 SOLIDS	1/ 4/ 5/ 1/1/0	CLEAR	1.3158	1.0417	1.0417	0.9259	0.9615	0.9091	0.9091	0.7937	0.8621
92	3RD OF 6 SOLIDS	1/ 4/ 5/ 1/1/0	CLEAR	1.3514	1.1111	1.0638	0.9615	0.8929	0.9804	0.8772	0.7813	0.8333
92	4TH OF 6 SOLIDS	2/ 5/14/ 0/3/0	CLEAR	1.1905	1.0000	0.9259	0.9615	0.8772	0.8621	0.7353	0.8333	0.7353
92	5TH OF 6 SOLIDS	2/16/14/ 0/5/0	9.755	1.1905	1.3158	1.0638	0.8772	0.8929	0.8197	0.5208	0.1695	0.0000
92	6TH OF 6 SOLIDS	2/ 9/14/ 0/5/0	8.735	1.4706	1.3158	1.0204	0.8929	0.6944	0.4902	0.2000	0.0000	0.0000
95	1ST OF 6 SOLIDS	1/ 8/ 5/ 1/2/0	CLEAR	0.0000	0.0000	0.0000	0.0000	0.0000	0.0000	0.0000	0.4762	0.5682
95	2ND OF 6 SOLIDS	2/ 7/15/ 0/3/0	CLEAR	0.0000	0.0000	0.0000	0.0000	0.0000	0.0000	0.0000	0.4717	0.5682
95	3RD OF 6 SOLIDS	2/ 6/14/ 0/3/0	CLEAR	0.0000	0.0000	0.0000	0.0000	0.0000	0.0000	0.0000	0.4762	0.5556
95	4TH OF 6 SOLIDS	1/ 0/ 0/11/1/0	CLEAR	1.3689	1.2500	0.9434	0.7143	0.7143	0.7246	0.4505	0.5051	0.3788
95	5TH OF 6 SOLIDS	2/ 5/14/ 0/3/0	CLEAR	1.3158	1.1364	1.0000	0.9259	0.8475	0.4545	0.3268	0.3185	0.1629
95	6TH OF 6 SOLIDS	2/ 5/14/ 0/3/0	CLEAR	1.3158	1.1628	1.0204	0.8197	0.6944	0.3145	0.2304	0.2137	0.2924
279	1ST OF 6 SOLIDS	1/ 6/ 6/ 1/1/0	CLEAR	1.2200	1.1111	1.1364	1.1364	1.0870	0.9615	0.7813	0.8197	0.7463
279	2ND OF 6 SOLIDS	1/ 5/ 6/ 1/1/0	CLEAR	1.1628	1.2195	1.0638	1.0870	1.0000	0.9615	0.7463	0.7692	0.8065
279	3RD OF 6 SOLIDS	1/ 6/ 6/ 1/1/0	CLEAR	1.1628	1.2195	1.0870	1.0000	0.9615	0.9615	0.7062	0.7463	0.8475
279	4TH OF 6 SOLIDS	2/11/14/ 0/3/0	CLEAR	1.4706	1.1364	1.0638	0.9615	0.9259	0.8197	0.7246	0.7143	0.6579
279	5TH OF 6 SOLIDS	2/ 5/14/ 0/3/0	CLEAR	1.6667	1.2821	0.9804	0.9615	1.1628	0.8621	0.6494	0.5319	0.4505
279	6TH OF 6 SOLIDS	2/ 5/14/ 0/3/0	CLEAR	1.6667	1.0638	0.9804	1.0638	0.9434	0.8475	0.5435	0.3165	0.2500
486	1ST OF 6 SOLIDS	1/ 2/ 4/ 1/2/0	CLEAR	0.0000	0.0000	0.0000	0.0000	0.0000	0.0000	0.0000	0.0000	0.0000
486	2ND OF 6 SOLIDS	1/ 5/ 4/ 1/2/0	CLEAR	0.0000	0.0000	0.0000	0.0000	0.0000	0.0000	0.0000	0.0000	0.0000
486	3RD OF 6 SOLIDS	1/ 3/ 4/ 1/2/0	CLEAR	0.0000	0.0000	0.0000	0.0000	0.0000	0.0000	0.0000	0.0000	0.0000
486	4TH OF 6 SOLIDS	1/ 5/ 5/ 1/2/0	CLEAR	0.0000	0.0000	0.0000	0.0000	0.0000	0.0000	0.0000	0.0000	0.0000
486	5TH OF 6 SOLIDS	1/ 5/ 5/ 1/2/0	CLEAR	0.0000	0.0000	0.0000	0.0000	0.0000	0.0000	0.0000	0.0000	0.0000
486	6TH OF 6 SOLIDS	2/12/14/ 0/5/0	CLEAR	0.0000	0.0000	0.5882	0.7937	0.8929	0.8621	0.6098	0.5952	0.4717
21	1ST OF 7 SOLIDS	4/ 5/14/ 0/3/0	CLEAR	2.1739	1.1905	1.1628	1.0638	0.9434	0.8772	0.9091	0.8621	0.8772
21	2ND OF 7 SOLIDS	2/ 5/14/ 0/3/0	CLEAR	2.0000	1.1905	1.0638	1.0417	1.0000	0.9259	0.8333	0.8197	0.7937
21	3RD OF 7 SOLIDS	2/ 5/14/ 0/3/0	CLEAR	1.7857	1.1628	0.9804	1.0000	1.0000	0.9804	0.8772	0.8197	0.7692
21	4TH OF 7 SOLIDS	2/ 5/14/ 0/3/0	CLEAR	1.3889	1.1905	1.1364	1.0870	1.0000	0.8772	0.7692	0.6667	0.6944
21	5TH OF 7 SOLIDS	2/ 5/14/ 0/3/0	CLEAR	1.6129	1.3514	1.0870	0.9804	0.8929	0.8065	0.6329	0.5747	0.4545
21	6TH OF 7 SOLIDS	2/ 5/14/ 0/3/0	CLEAR	1.5625	1.2821	1.0870	0.9615	0.8772	0.7813	0.6024	0.5435	0.4386
21	7TH OF 7 SOLIDS	2/ 5/14/ 0/3/0	CLEAR	1.5152	1.2821	1.0417	0.9615	0.8333	0.7463	0.5495	0.5495	0.4762
160	1ST OF 7 SOLIDS	1/ 4/ 5/ 1/1/0	CLEAR	1.3889	1.1905	1.1111	1.0638	0.9804	0.9091	0.7463	0.7692	0.9615
160	2ND OF 7 SOLIDS	1/ 4/ 5/ 1/1/0	CLEAR	1.3889	1.1905	1.1111	1.0870	0.9615	0.9091	0.7576	0.7692	0.9259
160	3RD OF 7 SOLIDS	1/ 3/ 5/ 1/1/0	CLEAR	1.3889	1.1905	1.1111	1.2821	0.8772	0.9804	0.7692	0.7576	0.8333
160	4TH OF 7 SOLIDS	1/ 3/ 5/ 1/1/0	CLEAR	1.3889	1.1905	1.1111	1.2821	0.8772	0.9615	0.7463	0.7463	0.7463
160	5TH OF 7 SOLIDS	1/ 4/ 5/ 1/1/0	CLEAR	1.3889	1.1905	1.1111	1.3158	1.1364	0.7692	0.7463	0.7463	0.7246
160	6TH OF 7 SOLIDS	1/ 3/ 5/ 1/1/0	CLEAR	1.3889	1.1905	1.1111	1.0638	0.9804	0.9091	0.7576	0.7463	0.7143
160	7TH OF 7 SOLIDS	5/11/14/12/5/4	CLEAR	1.3889	1.1905	1.1111	0.9091	0.8333	0.7246	0.6386	0.2347	0.1381
161	1ST OF 7 SOLIDS	1/ 5/ 5/ 1/2/0	CLEAR	1.3889	1.3514	0.8621	1.0870	1.0870	0.9804	0.6757	0.5102	0.8065
161	2ND OF 7 SOLIDS	1/ 5/ 5/ 1/2/0	CLEAR	1.3158	1.2821	0.8929	1.0870	1.0000	0.9804	0.6667	0.5495	0.7463
161	3RD OF 7 SOLIDS	1/ 4/ 5/ 1/2/0	CLEAR	1.2500	1.1628	1.0204	1.0000	0.9434	0.9615	0.6757	0.5747	0.7246
161	4TH OF 7 SOLIDS	1/ 4/ 5/ 1/2/0	CLEAR	1.1628	1.1364	1.1628	0.9091	0.9091	0.6667	0.6944	0.6098	0.5495
161	5TH OF 7 SOLIDS	2/ 9/14/ 0/5/0	10.255	1.2500	1.0204	0.8929	1.0000	0.8772	0.8065	0.5376	0.1992	0.0000
161	6TH OF 7 SOLIDS	2/ 5/14/ 0/3/0	8.755	1.4706	1.1628	1.0204	0.7813	0.4673	0.3086	0.0000	0.0000	0.0000
161	7TH OF 7 SOLIDS	2/ 5/14/ 0/3/0	7.915	1.6286	1.1364	1.0204	0.7463	0.4065	0.2941	0.0000	0.0000	0.0000

324	1ST OF 7 SOLIDS	2/ 3/ 4/ 1/2/0	CLEAR	1.4286	1.0000	1.0000	1.0638	1.0638	0.8772	0.6173	0.8333	0.7937
324	2ND OF 7 SOLIDS	1/ 3/ 4/ 1/2/0	CLEAR	1.4286	1.0000	1.0000	1.0638	1.0638	0.8772	0.6173	0.8333	0.7937
324	3RD OF 7 SOLIDS	1/ 3/ 4/ 1/2/0	CLEAR	1.4286	1.0000	1.0000	1.0638	1.0638	0.8772	0.6173	0.8333	0.7937
324	4TH OF 7 SOLIDS	2/13/14/ 0/3/0	CLEAR	1.3158	1.1628	0.8929	0.9804	0.8197	0.7813	0.4950	0.3106	0.1101
324	5TH OF 7 SOLIDS	2/ 7/14/ 0/3/0	6.245	1.5625	1.1111	0.9615	0.6757	0.0000	0.0000	0.0000	0.0000	0.0000
324	6TH OF 7 SOLIDS	2/ 7/14/ 0/3/0	6.095	1.6129	1.0638	0.8333	0.3623	0.0000	0.0000	0.0000	0.0000	0.0000
324	7TH OF 7 SOLIDS	2/ 9/14/ 0/3/0	5.355	1.6667	1.0638	0.5155	0.0000	0.0000	0.0000	0.0000	0.0000	0.0000
108	1ST OF 8 SOLIDS	1/ 4/ 4/ 1/2/0	CLEAR	1.2821	1.1905	1.1628	1.0870	1.1628	0.8772	0.7937	0.6849	0.8065
108	2ND OF 8 SOLIDS	1/ 4/ 4/ 1/2/0	CLEAR	1.2821	1.1905	1.1628	1.0870	1.1628	0.8772	0.7937	0.6849	0.8065
108	3RD OF 8 SOLIDS	1/ 5/ 8/ 1/2/0	11.003	1.2821	1.1905	1.1628	1.0870	1.1628	0.8772	0.7937	0.6849	0.8065
108	4TH OF 8 SOLIDS	1/ 5/ 6/ 1/2/0	10.815	1.2821	1.1905	1.1628	1.0870	1.1628	0.8772	0.7937	0.6849	0.8065
108	5TH OF 8 SOLIDS	2/ 7/14/ 0/5/0	10.475	1.4286	1.1111	1.0000	1.0000	0.7813	0.6379	0.5155	0.3311	0.0000
108	6TH OF 8 SOLIDS	2/ 9/14/ 0/3/0	10.215	1.4286	1.1111	1.0204	0.9091	0.7813	0.6379	0.4854	0.2778	0.0000
108	7TH OF 8 SOLIDS	2/ 7/13/ 0/5/0	9.865	1.3889	1.2195	1.0638	0.8197	0.7353	0.6579	0.3937	0.2941	0.0000
108	8TH OF 8 SOLIDS	2/ 9/14/ 0/5/0	8.815	1.3889	1.1364	0.9804	0.8475	0.6757	0.5952	0.2632	0.0000	0.0000
110	1ST OF 8 SOLIDS	1/ 5/ 8/ 1/2/0	CLEAR	0.0000	0.0000	0.0000	0.0000	0.0000	0.0000	0.0000	0.0000	0.0000
110	2ND OF 8 SOLIDS	1/ 5/ 6/ 1/2/0	CLEAR	0.0000	0.0000	0.0000	0.0000	0.0000	0.0000	0.0000	0.0000	0.0000
110	3RD OF 8 SOLIDS	2/ 7/14/ 0/5/0	CLEAR	0.0000	0.0000	0.0000	0.0000	0.0000	0.0000	0.0000	0.0000	0.0000
110	4TH OF 8 SOLIDS	2/ 9/14/ 0/3/0	CLEAR	0.0000	0.0000	0.0000	0.0000	0.0000	0.0000	0.0000	0.0000	0.0000
110	5TH OF 8 SOLIDS	2/ 7/13/ 0/5/0	CLEAR	0.0000	0.0000	0.0000	0.0000	0.0000	0.0000	0.0000	0.0000	0.0000
110	6TH OF 8 SOLIDS	2/ 9/14/ 0/5/0	CLEAR	0.0000	0.0000	0.0000	0.0000	0.0000	0.0000	0.0000	0.0000	0.0000
110	7TH OF 8 SOLIDS	2/ 4/14/ 0/3/0	CLEAR	0.0000	0.0000	0.0000	0.0000	0.0000	0.0000	0.0000	0.0000	0.0000
110	8TH OF 8 SOLIDS	2/ 9/14/ 0/5/0	CLEAR	0.0000	0.0000	0.0000	0.0000	0.0000	0.0000	0.0000	0.6849	0.3311
61	1ST OF 9 SOLIDS	1/ 3/ 6/ 1/1/0	CLEAR	1.0000	1.0870	0.9615	0.8197	0.8197	1.0000	0.7246	0.7692	0.6944
61	2ND OF 9 SOLIDS	1/ 3/ 6/ 1/1/0	CLEAR	1.0000	1.0870	1.0204	0.7692	0.8197	0.9091	0.7376	0.7042	0.6410
61	3RD OF 9 SOLIDS	1/ 3/ 6/ 1/1/0	CLEAR	1.0000	0.9804	0.9259	0.8475	0.8772	0.7813	0.7692	0.6849	0.6024
61	4TH OF 9 SOLIDS	1/ 3/ 6/ 1/1/0	CLEAR	1.0000	0.9615	0.8929	0.8621	0.8197	0.8065	0.7692	0.6667	0.5952
61	5TH OF 9 SOLIDS	1/ 3/ 6/ 1/1/0	CLEAR	1.0000	0.9804	0.8621	0.8065	0.7353	0.7937	0.6757	0.5952	0.4854
61	6TH OF 9 SOLIDS	1/ 4/ 6/ 1/1/0	CLEAR	1.0417	0.9804	0.8621	0.8065	0.7353	0.7937	0.6757	0.5952	0.4854
61	7TH OF 9 SOLIDS	2/ 5/14/ 0/3/0	CLEAR	1.0417	1.0000	0.8929	0.8065	0.8333	0.7937	0.6490	0.5102	0.4310
61	8TH OF 9 SOLIDS	2/ 5/14/ 0/3/0	CLEAR	1.0870	1.0417	0.8197	0.7937	0.7937	0.7813	0.5376	0.5208	0.4505
61	9TH OF 9 SOLIDS	2/11/14/ 0/3/0	CLEAR	1.2500	1.3158	1.1905	1.0417	0.7937	0.6490	0.6024	0.3571	0.1976
444	1ST OF 9 SOLIDS	1/ 3/ 2/ 1/2/0	CLEAR	1.3889	1.1905	1.2195	1.1111	1.0870	0.9804	0.7463	0.7463	0.7353
444	2ND OF 9 SOLIDS	1/ 4/ 5/ 1/2/0	CLEAR	1.1905	1.1905	1.2195	1.0638	1.0000	0.9091	0.7042	0.7937	0.8621
444	3RD OF 9 SOLIDS	1/ 5/ 5/ 1/2/0	CLEAR	1.1905	1.1364	1.1364	1.0638	0.8621	0.9091	0.7813	0.8621	0.8621
444	4TH OF 9 SOLIDS	1/ 3/ 5/ 1/2/0	CLEAR	1.3889	1.1628	0.9434	0.9434	0.7813	1.0204	0.8197	0.7463	0.8621
444	5TH OF 9 SOLIDS	1/ 2/ 4/ 1/2/0	CLEAR	1.5625	1.1905	0.7246	1.0000	0.7042	0.9615	0.7143	0.7353	0.7463
444	6TH OF 9 SOLIDS	1/ 4/ 5/ 1/2/0	9.795	1.0417	1.1905	1.1905	0.9259	0.7937	0.8333	0.6173	0.2370	0.0000
444	7TH OF 9 SOLIDS	6/ 5/14/ 0/3/0	9.715	1.0404	1.1364	1.0638	1.0204	0.8475	0.8197	0.5952	0.1502	0.0000
444	8TH OF 9 SOLIDS	2/12/12/ 0/3/0	9.585	1.4706	1.1111	1.0417	0.9434	0.8333	0.7042	0.4368	0.0000	0.0000
444	9TH OF 9 SOLIDS	2/ 7/14/ 0/5/0	9.035	1.3158	1.0870	0.9615	0.7937	0.7576	0.5682	0.2857	0.0000	0.0000
348	1ST OF *12 SOLIDS	2/ 9/14/ 0/5/0	CLEAR	0.0000	0.0000	0.0000	0.0000	0.0000	0.0000	0.0000	0.0000	0.0000
348	2ND OF *12 SOLIDS	2/13/14/ 0/5/0	CLEAR	0.0000	0.0000	0.0000	0.0000	0.0000	0.0000	0.0000	0.0000	0.0000
348	3RD OF *12 SOLIDS	2/ 9/15/ 0/5/0	CLEAR	0.0000	0.0000	0.0000	0.0000	0.0000	0.0000	0.0000	0.0000	0.0000
348	4TH OF *12 SOLIDS	2/ 6/14/ 0/5/0	CLEAR	0.0000	0.0000	0.0000	0.0000	0.0000	0.0000	0.0000	0.0000	0.5263
348	5TH OF *12 SOLIDS	2/ 6/14/ 0/5/0	CLEAR	0.0000	0.0000	0.0000	0.0000	0.0000	0.0000	0.0000	0.0000	0.5263
348	6TH OF *12 SOLIDS	1/ 4/ 6/ 1/1/0	CLEAR	1.4706	1.1628	1.2500	1.1905	0.9804	0.9615	0.2246	0.5319	0.4505
348	7TH OF *12 SOLIDS	1/ 9/ 0/22/1/0	CLEAR	1.2821	1.1905	1.0417	0.9804	0.8772	1.0204	0.8197	0.6024	0.4717
348	8TH OF *12 SOLIDS	1/ 6/ 5/ 1/1/0	CLEAR	1.4286	1.1364	1.0870	1.1111	1.0000	1.0204	0.8475	0.6173	0.4762
348	9TH OF *12 SOLIDS	2/ 9/14/ 0/3/0	CLEAR	1.4706	1.0870	1.1111	1.1111	1.0204	1.0204	0.8772	0.6173	0.4762
348	*10TH OF *12 SOLIDS	2/ 7/14/ 0/3/0	CLEAR	1.4706	1.2195	1.1628	1.0000	1.0000	1.0000	0.7813	0.5814	0.468
348	*11TH OF *12 SOLIDS	2/ 7/14/ 0/3/0	CLEAR	1.5625	1.3514	1.2195	1.0204	0.9091	0.8772	0.6410	0.5102	0.42
348	*12TH OF *12 SOLIDS	2/ 7/14/ 0/3/0	CLEAR	1.5625	1.3158	1.1905	0.9804	0.9259	0.8621	0.6250	0.4808	0.40

A3 - 6 Comp. Check No. 3600, Male Branch-Line Installation (W.C.6), Gradient 1:150.

GREENWICH DISTRICT HOSPITAL, ON SITE
 MONITORING OF ABOVE GROUND DRAINAGE.
 DR. J. A. SWAFFIELD AND MR. S. D. BOKCR.
 DRAINAGE RESEARCH GROUP, DEPARTMENT OF
 BUILDING TECHNOLOGY - BRUNEL UNIVERSITY.

ORANGE W.C. GRADIENT = 1:150.
 MALE SUITE OF W.C. S.

NUMBER OF RUNS UNDER COMPARISON = 769 .

VELOCITY MEASURING POINT:
 DISTANCE (M) FROM W.C.: 2.065 3.665 4.665 5.665 6.665 7.665 8.665 9.665
 SENSOR SEPARATION (M) : 1.0 1.0 1.0 1.0 1.0 1.0 1.0 1.0

RUN NO. RELATIVE POSH. CLASSIFICATION STOP
 SOLID IN FLUSH. NO. OF SOLID. POSN.

VELOCITY, M/S.

Run No.	Relative Posh.	Classification	Stop	1	2	3	4	5	6	7	8	9
7	NO OTHER SOLID	2/ 9/14/ 0/3/0	CLEAR	0.7692	0.9091	0.8772	0.8475	0.8065	0.7692	0.5814	0.5882	0.5376
16	NO OTHER SOLID	2/11/13/ 0/3/0	CLEAR	0.9804	1.0000	0.9615	0.8197	0.8197	0.8065	0.6667	0.6579	0.5747
18	NO OTHER SOLID	2/ 5/14/ 0/3/0	CLEAR	0.9434	0.9804	0.7937	0.8333	0.7937	0.7813	0.6250	0.5556	0.5208
23	NO OTHER SOLID	2/ 9/13/ 0/3/0	CLEAR	1.0638	0.9434	0.8621	0.8772	0.8065	0.8065	0.7576	0.7042	0.7937
30	NO OTHER SOLID	2/ 7/14/ 0/3/0	CLEAR	0.8475	0.7692	0.7813	0.6757	0.5952	0.4808	0.3448	0.3401	0.4098
31	NO OTHER SOLID	1/ 5/ 2/ 1/1/0	CLEAR	0.9434	0.8333	0.9091	0.8333	0.8197	0.7576	0.5155	0.5556	0.6250
60	NO OTHER SOLID	5/ 7/14/ 0/3/6	CLEAR	1.0000	1.0638	0.8475	0.8197	0.7937	0.7937	0.3448	0.4274	0.2500
87	NO OTHER SOLID	2/ 5/14/ 0/3/0	CLEAR	1.2821	1.0417	1.0000	0.9434	0.9259	0.9434	0.7692	1.0000	0.7937
121	NO OTHER SOLID	2/ 5/14/ 0/3/0	CLEAR	1.0417	0.9804	1.0204	0.9091	0.7937	0.7692	0.7353	0.7463	0.7246
129	NO OTHER SOLID	2/ 5/16/ 0/3/0	CLEAR	0.8197	0.8333	0.7813	0.7042	0.6410	0.5319	0.3333	0.2488	0.2924
136	NO OTHER SOLID	2/12/13/ 0/5/0	CLEAR	0.8929	0.8333	0.8929	0.8065	0.7042	0.6494	0.4630	0.4237	0.4032
147	NO OTHER SOLID	2/ 9/14/11/5/4	CLEAR	0.8929	0.7813	0.8621	0.8675	0.7463	0.7463	0.4950	0.3012	0.2674
179	NO OTHER SOLID	2/ 7/14/ 0/3/0	CLEAR	0.8475	0.8772	0.9259	0.8333	0.8197	0.7463	0.5263	0.5376	0.4902
180	NO OTHER SOLID	1/ 0/ 0/ 4/1/0	CLEAR	1.0870	0.7576	0.8197	0.8333	0.5882	0.5319	0.3906	0.4310	0.4348
184	NO OTHER SOLID	2/ 5/14/ 0/5/0	8.355	0.7463	0.7143	0.6950	0.2959	0.2183	0.1754	0.0000	0.0000	0.0000
185	NO OTHER SOLID	2/ 5/14/ 0/5/0	CLEAR	0.0000	0.0000	0.0000	0.0000	0.0000	0.0000	0.0000	0.6098	0.6944
195	NO OTHER SOLID	2/ 5/16/ 0/3/0	CLEAR	1.0870	0.9434	0.9434	0.8065	0.7937	0.7813	0.5952	0.5747	0.5556
209	NO OTHER SOLID	2/ 7/14/ 0/3/0	CLEAR	0.8929	0.8475	0.7576	0.7246	0.6098	0.5682	0.3906	0.3731	0.3968
212	NO OTHER SOLID	2/ 7/14/30/3/3	5.225	0.7143	0.7353	0.3472	0.0000	0.0000	0.0000	0.0000	0.0000	0.0000
217	NO OTHER SOLID	6/ 7/15/ 0/3/0	CLEAR	0.0000	0.0000	0.0000	0.0000	0.0000	0.0000	0.0000	0.0000	0.0000
221	NO OTHER SOLID	2/ 7/14/ 0/3/0	CLEAR	0.8475	0.8475	0.8065	0.8197	0.6757	0.6667	0.4464	0.3846	0.3788

230	NO OTHER SOLID	2/ 7/14/ 0/5/0	CLEAR	0.0000	0.0000	0.0000	0.0000	0.0000	0.0000	0.7353	0.7353	0.7042	0.6944
235	NO OTHER SOLID	2/ 9/12/ 0/3/0	CLEAR	0.9434	1.0417	0.9804	0.8929	0.8333	0.7937	0.6944	0.7143	0.7246	
251	NO OTHER SOLID	2/ 7/14/ 0/5/0	CLEAR	0.8197	0.8197	0.8065	0.7042	0.5952	0.4808	0.2959	0.3143	0.2841	
280	NO OTHER SOLID	2/ 7/14/ 0/2/0	CLEAR	0.9459	0.8772	0.9091	0.7692	0.7353	0.7576	0.5952	0.5556	0.5000	
287	NO OTHER SOLID	2/12/14/ 0/3/0	CLEAR	0.7576	0.8197	0.7692	0.6329	0.3817	0.2809	0.2110	0.1852	0.2146	
295	NO OTHER SOLID	2/ 5/14/ 0/5/0	CLEAR	0.8772	0.7692	0.7143	0.5682	0.4902	0.3846	0.2793	0.3205	0.3067	
327	NO OTHER SOLID	2/ 7/14/ 0/3/0	CLEAR	0.9091	0.8929	0.9434	0.7937	0.8197	0.7937	0.5618	0.5882	0.5556	
337	NO OTHER SOLID	2/ 5/13/ 0/3/0	CLEAR	0.6494	0.4808	0.4464	0.4000	0.3968	0.3125	0.2415	0.2538	0.2463	
359	NO OTHER SOLID	2/14/13/ 0/5/0	CLEAR	0.9459	0.9259	0.8772	0.8621	0.7576	0.7576	0.6329	0.5618	0.4717	
375	NO OTHER SOLID	2/ 7/14/ 0/5/0	CLEAR	0.9459	0.8333	0.9259	0.8065	0.7813	0.7937	0.6024	0.5556	0.4950	
394	NO OTHER SOLID	2/ 8/14/ 0/3/0	CLEAR	0.0000	0.0000	0.0000	0.0000	0.7463	0.7042	0.6494	0.6579	0.6494	
431	NO OTHER SOLID	2/ 5/14/ 0/5/0	CLEAR	0.9091	0.8197	0.9091	0.8333	0.7937	0.7937	0.6098	0.5495	0.4950	
447	NO OTHER SOLID	2/12/14/ 0/2/0	CLEAR	0.0000	0.0000	0.0000	0.0000	0.0000	0.0000	0.6757	0.6667	0.5952	
457	NO OTHER SOLID	2/ 5/16/ 0/3/0	CLEAR	1.4286	0.9804	0.9804	0.8065	0.7813	0.7463	0.6667	0.6944	0.6329	
458	NO OTHER SOLID	2/10/14/ 0/5/0	CLEAR	1.0000	0.8929	1.0000	0.9259	0.8065	0.7813	0.7042	0.6667	0.6173	
478	NO OTHER SOLID	2/ 5/15/ 0/3/0	CLEAR	0.8475	0.8621	0.7937	0.7576	0.6667	0.5747	0.3401	0.3333	0.3876	
499	NO OTHER SOLID	2/ 7/14/ 0/3/0	CLEAR	0.8021	0.8772	0.8929	0.8772	0.7463	0.7353	0.5952	0.5263	0.5051	
2	1ST OF 2 SOLIDS	1/ 0/ 0/ 4/1/0	CLEAR	1.1905	1.3889	1.1111	0.8065	0.9434	0.6579	0.5814	0.4545	0.5051	
2	2ND OF 2 SOLIDS	1/ 4/ 6/ 1/1/0	CLEAR	1.2500	0.9615	0.7576	0.7692	0.7353	0.7042	0.6024	0.2924	0.3906	
4	1ST OF 2 SOLIDS	1/ 4/ 8/ 1/2/0	8.995	0.8429	0.8333	0.9091	0.7813	0.6667	0.4000	0.0000	0.0000	0.0000	
4	2ND OF 2 SOLIDS	2/ 5/16/ 0/3/0	8.905	0.9459	0.8197	0.7353	0.6494	0.4902	0.3759	0.0000	0.0000	0.0000	
8	1ST OF 2 SOLIDS	1/ 3/ 8/ 1/2/0	CLEAR	1.0000	0.7937	0.7143	0.7246	0.6494	0.5682	0.4274	0.2016	0.2203	
8	2ND OF 2 SOLIDS	2/11/14/ 0/3/0	CLEAR	0.7937	0.7353	0.8065	0.7143	0.6494	0.6098	0.4132	0.2092	0.2193	
68	1ST OF 2 SOLIDS	1/ 3/ 6/ 1/1/0	CLEAR	0.9434	1.1364	1.1364	1.1905	0.9259	0.8333	0.7353	0.6173	0.5882	
68	2ND OF 2 SOLIDS	2/11/14/ 0/3/0	CLEAR	0.8065	0.9259	0.7463	0.7463	0.7692	0.6944	0.5319	0.3704	0.2924	
80	1ST OF 2 SOLIDS	1/ 0/ 0/20/1/0	CLEAR	1.1111	1.1111	1.0638	0.9615	0.8333	0.7692	0.6757	0.6849	0.6944	
80	2ND OF 2 SOLIDS	2/ 7/15/ 0/3/0	CLEAR	0.8065	0.8475	0.7576	0.7576	0.6667	0.5556	0.3425	0.2203	0.2381	
88	1ST OF 2 SOLIDS	1/ 5/ 6/ 1/2/0	9.795	0.9804	0.9259	1.0000	0.8621	0.6098	0.6250	0.4545	0.0000	0.0000	
88	2ND OF 2 SOLIDS	2/12/14/ 0/3/0	7.155	0.7446	0.7143	0.5882	0.4310	0.0000	0.0000	0.0000	0.0000	0.0000	
127	1ST OF 2 SOLIDS	7/16/15/11/1/0	CLEAR	1.7441	0.9615	0.8621	0.7463	0.7813	0.6849	0.6410	0.5682	0.5263	
127	2ND OF 2 SOLIDS	2/ 5/14/ 0/3/6	CLEAR	1.8519	0.8621	0.8475	0.7353	0.8065	0.6944	0.5000	0.4808	0.4762	
140	1ST OF 2 SOLIDS	1/ 7/ 6/ 1/2/0	8.395	0.0000	0.0000	0.0000	0.0000	0.0000	0.2809	0.0000	0.0000	0.0000	
140	2ND OF 2 SOLIDS	2/13/15/ 0/3/0	8.305	0.0000	0.0000	0.6250	0.5814	0.4098	0.2604	0.0000	0.0000	0.0000	
148	1ST OF 2 SOLIDS	1/ 0/ 0/24/2/0	CLEAR	0.9434	0.9434	0.9434	0.8475	0.8197	0.8197	0.5319	0.5376	0.5102	
148	2ND OF 2 SOLIDS	1/ 4/ 6/ 1/2/0	9.285	1.0204	0.8929	0.8197	0.7937	0.6494	0.4664	0.1873	0.0000	0.0000	
191	1ST OF 2 SOLIDS	2/12/14/ 0/3/0	CLEAR	0.0000	0.0000	0.0000	0.0000	0.0000	0.0000	0.0000	0.0000	0.3676	
191	2ND OF 2 SOLIDS	2/13/14/ 0/5/0	CLEAR	0.0000	0.0000	0.0000	0.0000	0.0000	0.6849	0.6098	0.3012	0.3497	
198	1ST OF 2 SOLIDS	6/ 0/ 0/ 0/0/0	7.885	0.0000	0.0000	0.0000	0.0000	0.0000	0.0000	0.0000	0.0000	0.0000	
198	2ND OF 2 SOLIDS	2/ 7/13/ 0/5/0	7.725	0.0000	0.0000	0.0000	0.0000	0.0000	0.0000	0.0000	0.0000	0.0000	

237	1ST OF 2 SOLIDS	7/ 0/ 0/30/1/0	CLEAR	0.9434	1.1364	1.0638	1.0204	0.7813	0.7143	0.7937	0.7692	0.7463
237	2ND OF 2 SOLIDS	2/ 7/14/ 0/3/0	CLEAR	0.8475	0.7463	0.8333	0.7246	0.6173	0.4630	0.3247	0.2841	0.3205
247	1ST OF 2 SOLIDS	2/13/14/ 0/3/0	CLEAR	0.0000	0.0000	0.0000	0.0000	0.0000	0.0000	0.0000	0.5952	0.5495
247	2ND OF 2 SOLIDS	2/ 7/14/ 0/3/0	CLEAR	0.8197	0.7937	0.7937	0.7937	0.7042	0.6098	0.3268	0.3788	0.3937
250	1ST OF 2 SOLIDS	2/ 5/15/ 0/3/0	CLEAR	0.9434	1.0000	0.9804	0.9615	0.8475	0.7937	0.6849	0.6849	0.6849
250	2ND OF 2 SOLIDS	2/ 5/15/ 0/3/0	CLEAR	0.8429	0.8197	0.8333	0.7576	0.7042	0.6098	0.4032	0.3906	0.3937
273	1ST OF 2 SOLIDS	2/13/13/ 0/3/0	8.605	0.9434	0.8065	0.8475	0.6757	0.3876	0.2008	0.0000	0.0000	0.0000
273	2ND OF 2 SOLIDS	2/ 7/14/ 0/3/0	8.265	0.8533	0.7937	0.7143	0.5263	0.2083	0.1092	0.0000	0.0000	0.0000
282	1ST OF 2 SOLIDS	6/ 7/16/ 0/5/0	10.125	0.7576	0.7143	0.6849	0.6173	0.6173	0.4000	0.1730	0.0000	0.0000
282	2ND OF 2 SOLIDS	6/11/14/ 0/3/0	9.585	0.8197	0.7246	0.7143	0.6579	0.5952	0.3759	0.1479	0.0000	0.0000
285	1ST OF 2 SOLIDS	2/ 7/14/ 0/3/0	CLEAR	0.9091	0.8197	0.8772	0.8475	0.7353	0.7463	0.5618	0.4854	0.4545
285	2ND OF 2 SOLIDS	2/ 7/14/ 0/3/0	CLEAR	0.8429	0.8197	0.8621	0.8065	0.7576	0.7463	0.5263	0.4902	0.4587
291	1ST OF 2 SOLIDS	2/10/16/ 0/3/0	CLEAR	0.8065	0.8772	0.8621	0.8475	0.7937	0.7463	0.5952	0.4762	0.4310
291	2ND OF 2 SOLIDS	2/ 7/16/ 0/3/0	CLEAR	0.8772	0.9091	0.9091	0.8333	0.7692	0.7143	0.5208	0.4545	0.4505
297	1ST OF 2 SOLIDS	7/16/16/ 0/1/0	CLEAR	0.9429	0.8929	0.8772	0.8197	0.7576	0.7937	0.6494	0.7042	0.6849
297	2ND OF 2 SOLIDS	2/ 7/14/ 0/3/0	CLEAR	0.8429	0.8065	0.8929	0.8197	0.7143	0.7463	0.5495	0.3846	0.3311
301	1ST OF 2 SOLIDS	2/ 5/16/ 0/3/0	CLEAR	0.0000	0.0000	0.0000	0.0000	0.0000	0.0000	0.0000	0.0000	0.6250
301	2ND OF 2 SOLIDS	2/ 7/14/ 0/3/0	CLEAR	0.0000	0.0000	0.0000	0.0000	0.0000	0.0000	0.0000	0.6494	0.6098
306	1ST OF 2 SOLIDS	2/ 7/14/ 0/5/0	10.205	0.9015	0.7576	0.8621	0.8621	0.5618	0.4000	0.1650	0.0000	0.0000
306	2ND OF 2 SOLIDS	2/12/14/ 0/5/0	9.185	0.7576	0.8333	0.8475	0.5814	0.4237	0.2024	0.1080	0.0000	0.0000
307	1ST OF 2 SOLIDS	2/ 7/14/ 0/5/0	CLEAR	0.0000	0.0000	0.0000	0.0000	0.0000	0.0000	0.0000	0.0000	0.6944
307	2ND OF 2 SOLIDS	2/12/14/ 0/5/0	CLEAR	0.0000	0.0000	0.0000	0.0000	0.0000	0.0000	0.0000	0.0000	0.6944
316	1ST OF 2 SOLIDS	7/16/16/ 0/1/0	CLEAR	1.0038	1.0000	0.8333	0.8333	0.9434	0.8772	0.6944	0.7692	0.7143
316	2ND OF 2 SOLIDS	2/13/16/ 0/4/0	6.455	0.9091	0.8065	0.6667	0.4425	0.0000	0.0000	0.0000	0.0000	0.0000
345	1ST OF 2 SOLIDS	6/11/14/ 0/3/0	CLEAR	0.0000	0.0000	0.0000	0.0000	0.0000	0.0000	0.0000	0.0000	0.4854
345	2ND OF 2 SOLIDS	6/11/14/ 0/3/0	CLEAR	0.0000	0.0000	0.0000	0.0000	0.0000	0.0000	0.0000	0.0000	0.4386
357	1ST OF 2 SOLIDS	7/ 3/ 4/ 1/1/0	CLEAR	1.1405	1.0417	1.3514	1.0204	0.9259	1.0000	0.7463	0.6849	0.8197
357	2ND OF 2 SOLIDS	2/12/14/ 0/4/0	CLEAR	1.0417	0.7692	0.8929	0.8065	0.8333	0.5435	0.4167	0.2890	0.2841
370	1ST OF 2 SOLIDS	2/ 4/14/ 0/3/0	CLEAR	1.1405	1.0417	1.1628	0.9615	1.0000	0.8929	0.7576	0.7246	0.7463
370	2ND OF 2 SOLIDS	2/ 5/14/ 0/3/0	CLEAR	1.2821	1.0417	1.0204	0.9615	0.8929	0.7813	0.7576	0.7463	0.7937
397	1ST OF 2 SOLIDS	2/ 5/14/ 0/5/0	CLEAR	0.8429	0.8065	0.8772	0.8065	0.7353	0.6849	0.5952	0.5263	0.4348
397	2ND OF 2 SOLIDS	2/ 5/14/ 0/5/0	CLEAR	0.8475	0.8621	0.8475	0.7937	0.7246	0.7042	0.5263	0.4717	0.4368
401	1ST OF 2 SOLIDS	2/ 4/16/ 0/3/0	CLEAR	0.8621	0.8621	0.9434	0.8197	0.7813	0.7576	0.5747	0.5495	0.5155
401	2ND OF 2 SOLIDS	2/ 5/15/ 0/3/0	CLEAR	0.9429	0.7937	0.8333	0.7576	0.6849	0.6098	0.4202	0.4310	0.4348
403	1ST OF 2 SOLIDS	2/ 7/14/ 0/3/0	6.265	0.9429	0.6944	0.5952	0.2119	0.0000	0.0000	0.0000	0.0000	0.0000
403	2ND OF 2 SOLIDS	2/ 9/16/ 0/5/0	3.955	0.6410	0.0000	0.0000	0.0000	0.0000	0.0000	0.0000	0.0000	0.0000
404	1ST OF 2 SOLIDS	7/ 3/ 4/ 1/1/0	CLEAR	0.8772	0.7937	0.7576	0.8065	0.8475	0.7376	0.5882	0.6173	0.5495
404	2ND OF 2 SOLIDS	2/11/16/ 0/5/0	3.535	0.6279	0.0000	0.0000	0.0000	0.0000	0.0000	0.0000	0.0000	0.0000
443	1ST OF 2 SOLIDS	2/ 5/14/ 0/3/0	CLEAR	0.9091	0.8675	0.8621	0.8065	0.7937	0.8197	0.6667	0.6024	0.5882
443	2ND OF 2 SOLIDS	2/ 5/14/ 0/3/0	CLEAR	0.8197	0.8197	0.7692	0.6849	0.6329	0.5556	0.3472	0.4464	0.4854
475	1ST OF 2 SOLIDS	7/16/15/ 0/1/0	CLEAR	1.3214	1.1628	0.9091	0.8621	0.7937	0.7692	0.7246	0.8197	0.7463
475	2ND OF 2 SOLIDS	2/11/16/ 1/4/0	3.715	0.7143	0.0000	0.0000	0.0000	0.0000	0.0000	0.0000	0.0000	0.0000
500	1ST OF 2 SOLIDS	2/ 7/14/ 0/5/0	CLEAR	0.8621	0.9615	0.9091	0.8929	0.8929	0.8333	0.6410	0.6579	0.6494
500	2ND OF 2 SOLIDS	2/ 7/14/ 0/5/0	CLEAR	0.8475	0.8772	0.8772	0.8621	0.8197	0.7937	0.6410	0.5882	0.5556

3	1ST OF 3 SOLIDS	7/11/14/ 0/0/0	CLEAR	0.9434	1.0204	0.9804	0.8929	0.8929	0.8197	0.7937	0.6944	0.7576
3	2ND OF 3 SOLIDS	1/9/ 6/ 1/2/0	CLEAR	0.8772	0.9091	0.9434	0.8929	0.7042	0.7042	0.6098	0.3731	0.2778
3	3RD OF 3 SOLIDS	2/11/14/ 0/3/0	CLEAR	0.8475	0.7576	0.7813	0.7353	0.5376	0.3571	0.2273	0.1992	0.1859
12	1ST OF 3 SOLIDS	2/ 9/15/ 0/3/0	CLEAR	0.0000	0.0000	0.0000	0.0000	0.0000	0.0000	0.0000	0.0000	1.1111
12	2ND OF 3 SOLIDS	2/ 7/15/ 0/3/0	CLEAR	0.0000	0.0000	0.0000	0.0000	0.0000	0.0000	0.0000	0.0000	1.1111
12	3RD OF 3 SOLIDS	2/11/15/ 0/3/0	CLEAR	0.0000	0.0000	0.0000	0.0000	0.0000	0.0000	0.0000	0.0000	1.1111
16	1ST OF 3 SOLIDS	2/ 4/13/ 0/3/0	CLEAR	1.0000	0.9091	0.8621	0.8772	0.7813	0.7246	0.6250	0.5319	0.4902
16	2ND OF 3 SOLIDS	2/ 5/14/ 0/3/0	CLEAR	1.0000	0.9091	0.8772	0.8197	0.8333	0.6944	0.5556	0.5000	0.4545
16	3RD OF 3 SOLIDS	2/ 7/14/ 0/3/0	CLEAR	0.8065	0.7813	0.8333	0.6250	0.5495	0.4167	0.2404	0.2604	0.2809
33	1ST OF 3 SOLIDS	2/ 7/14/ 0/3/0	CLEAR	0.8429	0.8772	0.8929	0.7463	0.8197	0.8197	0.5814	0.4762	0.5435
33	2ND OF 3 SOLIDS	2/ 7/14/ 0/3/0	CLEAR	0.8475	0.7813	0.7463	0.7937	0.6849	0.5618	0.3185	0.1832	0.1938
33	3RD OF 3 SOLIDS	2/ 5/14/ 0/3/0	CLEAR	0.8475	0.7692	0.7463	0.7353	0.6494	0.5376	0.2660	0.1672	0.2119
40	1ST OF 3 SOLIDS	1/ 0/ 0/ 7/2/0	CLEAR	1.1628	1.0204	0.9091	0.8621	0.9091	0.8929	0.8333	0.7042	0.6024
40	2ND OF 3 SOLIDS	1/ 0/ 0/ 28/2/0	9.195	0.9615	0.8197	0.8475	0.6757	0.8197	0.6849	0.3788	0.0000	0.0000
40	3RD OF 3 SOLIDS	2/ 5/14/ 0/3/0	9.115	0.8197	0.8197	0.8197	0.7937	0.7692	0.6579	0.0000	0.0000	0.0000
44	1ST OF 3 SOLIDS	1/ 7/ 6/ 1/2/0	9.475	0.0000	0.0000	0.0000	0.0000	0.0000	0.0000	0.0000	0.0000	0.0000
44	2ND OF 3 SOLIDS	1/ 2/ 4/ 1/1/0	9.325	1.2195	1.0638	0.9804	0.9259	0.9434	0.9091	0.4274	0.0000	0.0000
44	3RD OF 3 SOLIDS	1/ 2/ 4/ 1/1/0	6.185	1.1628	0.9804	0.9091	0.7143	0.4803	0.0000	0.0000	0.0000	0.0000
50	1ST OF 3 SOLIDS	1/ 0/ 0/ 25/2/0	CLEAR	1.1628	1.0417	0.9615	0.9434	0.8475	0.8065	0.7576	0.6849	0.6667
50	2ND OF 3 SOLIDS	1/ 0/ 0/ 25/2/0	CLEAR	1.1564	1.0000	0.9091	0.8621	0.7353	0.7576	0.4423	0.5682	0.5155
50	3RD OF 3 SOLIDS	1/ 4/ 5/ 1/2/0	9.175	1.1628	0.9091	0.8772	0.8197	0.7246	0.6944	0.4423	0.0000	0.0000
63	1ST OF 3 SOLIDS	1/ 0/ 0/ 25/1/0	CLEAR	1.0417	1.0000	0.9091	0.8929	0.8621	0.8333	0.7042	0.7246	0.7246
63	2ND OF 3 SOLIDS	1/ 4/ 5/ 1/1/0	CLEAR	1.1111	0.9091	0.9434	0.8475	0.7937	0.8197	0.6494	0.6944	0.6667
63	3RD OF 3 SOLIDS	2/ 5/14/ 0/3/0	CLEAR	0.9091	0.8621	0.8772	0.8197	0.8065	0.7813	0.6024	0.5556	0.6717
73	1ST OF 3 SOLIDS	1/ 0/ 0/ 13/1/0	CLEAR	1.0870	1.0638	1.0417	0.9259	0.9091	0.8621	0.7692	0.7353	0.7042
73	2ND OF 3 SOLIDS	2/ 7/14/ 0/3/0	CLEAR	0.8772	0.9259	0.8475	0.8929	0.7813	0.7353	0.6173	0.4673	0.3846
73	3RD OF 3 SOLIDS	2/ 7/14/ 0/3/0	CLEAR	0.8533	0.8621	0.8929	0.8197	0.7353	0.7143	0.5000	0.4505	0.3968
79	1ST OF 3 SOLIDS	7/16/15/ 0/0/0	CLEAR	1.0870	1.1111	0.9259	0.7692	0.7692	0.9091	0.7042	0.6173	0.6494
79	2ND OF 3 SOLIDS	2/ 7/14/ 0/3/0	CLEAR	0.8475	0.7692	0.7937	0.7813	0.6579	0.3472	0.2451	0.1761	0.1623
79	3RD OF 3 SOLIDS	2/ 7/14/ 0/3/0	CLEAR	0.8197	0.8065	0.7813	0.6494	0.4425	0.2778	0.1984	0.1429	0.0882
93	1ST OF 3 SOLIDS	2/16/13/ 0/5/0	CLEAR	0.0000	0.0000	0.0000	0.0000	0.0000	0.0000	0.0000	0.0000	0.0000
93	2ND OF 3 SOLIDS	2/ 9/14/ 0/5/0	CLEAR	0.0000	0.0000	0.0000	0.0000	0.0000	0.0000	0.0000	0.0000	0.3759
93	3RD OF 3 SOLIDS	5/ 9/14/ 0/3/6	CLEAR	0.9091	0.8197	0.8929	1.0204	0.8772	0.7143	0.4167	0.2924	0.3676
100	1ST OF 3 SOLIDS	7/16/16/ 0/1/6	CLEAR	1.3889	1.2195	1.0000	0.8772	1.0417	0.7813	0.5882	0.7246	0.6579
100	2ND OF 3 SOLIDS	2/ 7/14/ 0/3/0	CLEAR	0.8197	0.8621	0.7937	0.8197	0.7692	0.6944	0.5376	0.4950	0.4202
100	3RD OF 3 SOLIDS	2/ 7/14/ 0/3/0	CLEAR	0.8475	0.8197	0.8197	0.9091	0.7576	0.7143	0.5102	0.4717	0.4237
120	1ST OF 3 SOLIDS	2/ 9/14/ 0/5/0	CLEAR	0.0000	0.0000	0.0000	0.0000	0.0000	0.0000	0.0000	0.3571	0.3205
120	2ND OF 3 SOLIDS	2/ 7/14/ 0/3/0	CLEAR	0.0000	0.0000	0.0000	0.0000	0.0000	0.0000	0.0000	0.3571	0.3205
120	3RD OF 3 SOLIDS	2/ 9/14/ 0/5/6	CLEAR	0.8475	0.8621	0.8475	0.8333	0.7353	0.7576	0.4237	0.3546	0.3086
139	1ST OF 3 SOLIDS	1/ 0/ 0/ 30/1/0	CLEAR	0.8772	0.8197	0.7576	0.6944	0.7246	0.7463	0.6494	0.5495	0.7576
139	2ND OF 3 SOLIDS	1/ 7/ 6/ 1/2/0	6.465	1.0638	0.7937	0.4630	0.6849	0.0000	0.0000	0.0000	0.0000	0.0000
139	3RD OF 3 SOLIDS	2/13/15/ 0/5/0	3.815	0.8929	0.0000	0.0000	0.0000	0.0000	0.0000	0.0000	0.0000	0.0000
144	1ST OF 3 SOLIDS	1/ 3/ 4/ 1/1/0	CLEAR	1.2000	1.2195	0.9804	1.0638	0.9259	0.8929	0.5495	0.7353	0.7937
144	2ND OF 3 SOLIDS	1/ 3/ 4/ 1/1/0	CLEAR	1.2195	1.1111	0.8333	1.0204	1.1111	0.9091	0.4664	0.5556	0.6579
144	3RD OF 3 SOLIDS	2/ 7/14/ 0/3/0	CLEAR	1.1111	0.9091	0.8929	0.8197	0.8621	0.7937	0.5952	0.6250	0.6173
152	1ST OF 3 SOLIDS	1/ 4/ 5/ 1/2/0	7.525	0.8475	0.8772	0.6098	0.5263	0.4348	0.0000	0.0000	0.0000	0.0000
152	2ND OF 3 SOLIDS	5/ 9/14/23/5/6	6.205	0.7143	0.6329	0.5000	0.2907	0.0000	0.0000	0.0000	0.0000	0.0000
152	3RD OF 3 SOLIDS	2/11/14/ 0/5/0	5.275	0.6744	0.6173	0.4425	0.0000	0.0000	0.0000	0.0000	0.0000	0.0000
153	1ST OF 3 SOLIDS	1/ 4/ 5/ 1/2/0	CLEAR	0.0000	0.0000	0.0000	0.0000	0.0000	0.0000	0.8772	0.8065	0.6494

153	2ND OF 3 SOLIDS	5/9/14/23/3/6	CLEAR	0.0000	0.0000	0.0000	0.0000	0.0000	0.0000	0.7246	0.6173	0.5155	0.4625
153	3RD OF 3 SOLIDS	2/11/14/ 0/5/0	CLEAR	0.0000	0.0000	0.0000	0.0000	0.0000	0.0000	0.6757	0.5495	0.5208	0.4032
162	1ST OF 3 SOLIDS	2/ 9/14/ 0/5/0	CLEAR	0.0000	0.0000	0.0000	0.0000	0.0000	0.0000	0.0000	0.0000	0.0000	0.0000
162	2ND OF 3 SOLIDS	2/ 5/14/ 0/3/0	CLEAR	0.0000	0.0000	0.0000	0.0000	0.0000	0.0000	0.0000	0.0000	0.3817	0.5208
162	3RD OF 3 SOLIDS	2/ 5/14/ 0/3/0	CLEAR	0.0000	0.0000	0.0000	0.0000	0.0000	0.0000	0.0000	0.0000	0.3817	0.5208
173	1ST OF 3 SOLIDS	1/ 7/ 4/ 1/1/0	CLEAR	1.3214	1.1628	1.1364	0.7692	0.7246	0.8065	0.8065	0.6329	0.4902	0.2551
173	2ND OF 3 SOLIDS	2/ 5/14/ 0/3/0	CLEAR	0.8772	0.8333	0.8197	0.7813	0.6944	0.5556	0.3906	0.3906	0.2488	0.2732
173	3RD OF 3 SOLIDS	2/ 5/14/ 0/3/0	CLEAR	0.8021	0.8333	0.8197	0.7813	0.6757	0.5435	0.3650	0.3650	0.2427	0.2825
182	1ST OF 3 SOLIDS	1/ 3/ 4/ 1/1/0	CLEAR	1.0204	1.0000	0.9804	0.9091	0.8772	0.7813	0.6410	0.6410	0.6849	0.6410
182	2ND OF 3 SOLIDS	2/ 9/14/ 0/3/0	CLEAR	0.8772	0.9091	0.8065	0.8065	0.7576	0.7042	0.4664	0.4664	0.2370	0.2000
182	3RD OF 3 SOLIDS	1/ 3/ 4/ 1/1/0	CLEAR	0.8772	0.8772	0.8333	0.7692	0.7692	0.6944	0.4000	0.4000	0.2404	0.2016
197	1ST OF 3 SOLIDS	2/ 7/15/ 0/3/0	CLEAR	0.7042	0.8065	0.9804	0.8772	0.6849	0.6667	0.4587	0.4587	0.3226	0.2304
197	2ND OF 3 SOLIDS	6/ 0/ 0/ 0/0/0	7.345	0.7446	0.6944	0.6098	0.3759	0.2183	0.0000	0.0000	0.0000	0.0000	0.0000
197	3RD OF 3 SOLIDS	2/ 7/13/ 0/3/0	7.225	0.6579	0.6250	0.5155	0.3185	0.2618	0.0000	0.0000	0.0000	0.0000	0.0000
203	1ST OF 3 SOLIDS	7/16/14/ 0/1/0	CLEAR	1.0870	1.0204	0.9615	0.9259	0.8065	0.7692	0.7463	0.7463	0.7246	0.6667
203	2ND OF 3 SOLIDS	2/10/14/ 0/3/0	CLEAR	0.9434	0.9615	0.8621	0.8197	0.7042	0.6250	0.4673	0.4673	0.4673	0.4854
203	3RD OF 3 SOLIDS	2/11/14/ 0/3/0	CLEAR	0.8333	0.8621	0.7813	0.7246	0.6250	0.5263	0.3401	0.3401	0.3468	0.3817
204	1ST OF 3 SOLIDS	5/12/14/ 0/2/6	10.625	1.0204	0.8197	0.8333	0.6849	0.4950	0.1908	0.0882	0.0882	0.0778	0.0000
204	2ND OF 3 SOLIDS	2/10/14/ 0/3/0	8.645	0.4237	0.4274	0.3356	0.3145	0.2252	0.0984	0.0000	0.0000	0.0000	0.0000
204	3RD OF 3 SOLIDS	2/ 4/14/ 0/3/0	8.185	0.4237	0.4274	0.3356	0.3145	0.2252	0.0984	0.0000	0.0000	0.0000	0.0000
214	1ST OF 3 SOLIDS	5/ 7/14/30/3/3	CLEAR	0.0000	0.0000	0.0000	0.0000	0.0000	0.0000	0.0000	0.0000	0.0000	0.0000
214	2ND OF 3 SOLIDS	6/ 9/14/ 0/3/0	9.105	0.7576	0.7463	0.6757	0.5882	0.3937	0.1931	0.0000	0.0000	0.0000	0.0000
214	3RD OF 3 SOLIDS	6/11/14/ 0/3/0	8.255	0.7092	0.6494	0.6329	0.5556	0.1730	0.1147	0.0000	0.0000	0.0000	0.0000
215	1ST OF 3 SOLIDS	6/ 9/14/ 0/3/0	CLEAR	0.0000	0.0000	0.0000	0.0000	0.0000	0.0000	0.0000	0.0000	0.3876	0.3425
215	2ND OF 3 SOLIDS	6/11/14/ 0/3/0	CLEAR	0.0000	0.0000	0.0000	0.0000	0.0000	0.0000	0.0000	0.0000	0.3876	0.3425
215	3RD OF 3 SOLIDS	6/ 7/15/ 0/3/0	6.575	0.7537	0.6494	0.7143	0.5952	0.0000	0.0000	0.0000	0.0000	0.0000	0.0000
228	1ST OF 3 SOLIDS	1/ 3/ 5/ 1/1/0	CLEAR	1.3214	0.9434	0.9259	0.8197	0.7576	0.7246	0.6849	0.6849	0.6944	0.6410
228	2ND OF 3 SOLIDS	1/ 2/ 4/ 1/1/0	CLEAR	1.3214	0.9434	0.9259	0.8197	0.7576	0.7246	0.6849	0.6849	0.6944	0.6410
228	3RD OF 3 SOLIDS	5/ 9/16/23/3/3	8.195	0.8197	0.7576	0.7353	0.5814	0.4902	0.1235	0.0000	0.0000	0.0000	0.0000
262	1ST OF 3 SOLIDS	5/11/14/21/3/1	CLEAR	0.0000	0.0000	0.0000	0.0000	0.0000	0.0000	0.0000	0.0000	0.0000	0.0000
262	2ND OF 3 SOLIDS	2/ 5/16/ 0/3/0	CLEAR	0.0000	0.0000	0.0000	0.0000	0.0000	0.0000	0.0000	0.0000	0.0000	0.0000
262	3RD OF 3 SOLIDS	2/ 9/14/ 0/3/0	CLEAR	1.0000	0.9091	0.9804	0.8621	0.8621	0.8621	0.8621	0.6667	0.6494	0.6250
267	1ST OF 3 SOLIDS	1/ 5/ 5/ 1/2/0	CLEAR	0.9259	1.0638	0.8929	0.7937	0.7813	0.7937	0.6944	0.6944	0.5263	0.2212
267	2ND OF 3 SOLIDS	1/ 7/ 5/ 1/2/0	CLEAR	0.7937	1.0417	0.8929	0.6667	0.6250	0.6173	0.6250	0.6250	0.3247	0.2415
267	3RD OF 3 SOLIDS	5/11/14/23/3/3	CLEAR	0.7092	0.7692	0.8621	0.6667	0.5682	0.4387	0.2857	0.2857	0.1441	0.1706
270	1ST OF 3 SOLIDS	1/ 5/ 6/ 1/2/0	CLEAR	0.0000	0.0000	0.0000	0.0000	0.0000	0.0000	0.0000	0.0000	0.0000	0.4673
270	2ND OF 3 SOLIDS	2/ 7/14/ 0/3/0	CLEAR	0.0000	0.0000	0.0000	0.0000	0.0000	0.0000	0.0000	0.0000	0.0000	0.4673
270	3RD OF 3 SOLIDS	2/ 7/14/ 0/3/0	CLEAR	0.8929	0.7576	0.7353	0.5556	0.4202	0.3067	0.1901	0.1901	0.1385	0.1302
292	1ST OF 3 SOLIDS	1/ 2/ 4/ 1/2/0	CLEAR	0.8475	0.8621	0.8621	0.8929	0.8197	0.6667	0.6250	0.6250	0.7353	0.7163
292	2ND OF 3 SOLIDS	1/ 6/ 6/ 1/2/0	CLEAR	0.8475	0.8475	0.8475	0.7937	0.5613	0.6849	0.6757	0.6757	0.6579	0.5618
292	3RD OF 3 SOLIDS	2/11/14/ 0/3/0	CLEAR	0.8197	0.7692	0.7692	0.7463	0.6250	0.4237	0.2203	0.2203	0.1479	0.1099
315	1ST OF 3 SOLIDS	1/ 7/ 8/ 1/2/0	CLEAR	0.0000	0.0000	0.0000	0.0000	0.0000	0.0000	0.0000	0.0000	0.0000	0.1377
315	2ND OF 3 SOLIDS	2/11/14/ 0/3/0	CLEAR	0.0000	0.0000	0.0000	0.0000	0.0000	0.0000	0.0000	0.0000	0.0000	0.1374
315	3RD OF 3 SOLIDS	2/ 5/14/ 0/3/0	CLEAR	0.0000	0.0000	0.0000	0.0000	0.0000	0.0000	0.0000	0.0000	0.2066	0.1259
352	1ST OF 3 SOLIDS	2/ 5/14/ 0/5/0	CLEAR	0.8021	0.8475	0.8929	0.7937	0.7692	0.7463	0.6173	0.6173	0.5814	0.5102
352	2ND OF 3 SOLIDS	2/ 7/12/ 0/3/0	CLEAR	0.8929	0.8621	0.8929	0.8333	0.7353	0.7463	0.6098	0.6098	0.5556	0.5051
352	3RD OF 3 SOLIDS	2/ 5/14/ 0/5/0	CLEAR	0.8929	0.8197	0.8929	0.8333	0.7463	0.7266	0.5952	0.5952	0.5435	0.4950
361	1ST OF 3 SOLIDS	1/ 2/ 4/ 1/2/0	CLEAR	1.0000	1.0000	0.9434	0.9091	0.7692	0.6849	0.5051	0.5051	0.3906	0.8065
361	2ND OF 3 SOLIDS	1/ 2/ 6/ 1/2/0	8.365	1.0000	0.9813	0.8772	0.8333	0.6024	0.0701	0.0000	0.0000	0.0000	0.0000
361	3RD OF 3 SOLIDS	2/13/14/ 0/5/0	8.285	0.8533	0.7143	0.6173	0.3731	0.2315	0.0849	0.0000	0.0000	0.0000	0.0000

363	1ST OF 3 SOLIDS	2/12/14/	0/5/0	CLEAR	0.8197	0.8621	0.7937	0.7463	0.7463	0.5814	0.4673	0.4274
363	2ND OF 3 SOLIDS	2/ 4/14/	0/3/0	CLEAR	0.7576	0.7463	0.5952	0.5435	0.5402	0.3205	0.3759	0.4274
363	3RD OF 3 SOLIDS	2/ 3/12/	0/3/0	CLEAR	0.7353	0.6494	0.5319	0.5051	0.4545	0.2646	0.4032	0.4717
386	1ST OF 3 SOLIDS	1/ 4/ 4/	1/1/0	CLEAR	0.7813	0.8333	0.8621	0.7143	0.8197	0.6849	0.5435	0.5102
386	2ND OF 3 SOLIDS	2/13/14/	0/5/0	CLEAR	0.9259	0.8333	0.8475	0.7246	0.8197	0.6410	0.5682	0.5000
386	3RD OF 3 SOLIDS	2/ 5/14/	0/3/0	CLEAR	0.7692	0.8333	0.7813	0.7143	0.6757	0.4854	0.4854	0.4545
400	1ST OF 3 SOLIDS	5/11/14/	0/5/6	CLEAR	0.8197	0.7937	0.7692	0.7353	0.6250	0.2591	0.2500	0.1553
400	2ND OF 3 SOLIDS	2/ 9/14/	0/3/0	CLEAR	0.7692	0.7937	0.7463	0.5882	0.4348	0.2427	0.1623	0.1908
400	3RD OF 3 SOLIDS	2/ 7/12/	0/3/0	CLEAR	0.8772	0.7813	0.6579	0.5319	0.3333	0.1548	0.1217	0.1220
411	1ST OF 3 SOLIDS	2/11/14/	0/3/0	CLEAR	0.0000	0.7246	0.7353	0.6849	0.7463	0.6173	0.5208	0.4274
411	2ND OF 3 SOLIDS	7/16/16/	0/1/0	CLEAR	1.3689	0.7143	0.7246	0.6757	0.7353	0.6173	0.4902	0.4000
411	3RD OF 3 SOLIDS	2/ 5/14/	0/3/0	CLEAR	0.8333	0.7813	0.6410	0.5814	0.5155	0.3333	0.3759	0.4167
415	1ST OF 3 SOLIDS	5/11/14/	0/3/7	CLEAR	0.9434	0.9615	0.9259	0.6410	0.7042	0.6329	0.4902	0.5376
415	2ND OF 3 SOLIDS	2/ 9/14/	0/3/0	5.665	0.7246	0.6098	0.0000	0.0000	0.0000	0.0000	0.0000	0.0000
415	3RD OF 3 SOLIDS	2/ 9/14/	0/3/0	5.465	0.7042	0.5208	0.0000	0.0000	0.0000	0.0000	0.0000	0.0000
439	1ST OF 3 SOLIDS	6/16/14/	0/1/0	CLEAR	1.1564	1.1628	0.9259	0.9259	1.0000	0.8475	0.7463	0.7813
439	2ND OF 3 SOLIDS	2/ 5/14/	0/3/0	CLEAR	0.8065	0.7813	0.6250	0.4545	0.3247	0.2525	0.2392	0.2618
439	3RD OF 3 SOLIDS	2/ 5/14/	0/3/0	CLEAR	0.7692	0.7463	0.5952	0.4464	0.3145	0.2463	0.2392	0.2646
468	1ST OF 3 SOLIDS	1/ 7/ 6/	1/2/0	CLEAR	0.0000	0.0000	0.0000	0.0000	0.0000	0.0000	0.0000	0.3521
468	2ND OF 3 SOLIDS	2/ 4/16/	0/5/0	CLEAR	0.0000	0.0000	0.0000	0.0000	0.0000	0.0000	0.3289	0.3448
468	3RD OF 3 SOLIDS	2/ 7/14/	0/3/0	CLEAR	0.0000	0.0000	0.0000	0.0000	0.0000	0.0000	0.3333	0.3401
477	1ST OF 3 SOLIDS	2/11/14/	0/3/0	CLEAR	0.0000	0.0000	0.0000	0.0000	0.0000	0.0000	0.0000	0.5814
477	2ND OF 3 SOLIDS	2/14/13/	0/5/0	CLEAR	1.2821	0.7576	0.8772	0.8065	0.7246	0.5952	0.4854	0.6173
477	3RD OF 3 SOLIDS	2/13/13/	0/5/0	CLEAR	1.0638	0.8929	0.8475	0.7692	0.7692	0.5556	0.5208	0.5051
491	1ST OF 3 SOLIDS	2/ 5/14/	0/5/0	CLEAR	0.9804	0.8772	0.8621	0.8333	0.8772	0.6329	0.6410	0.6250
491	2ND OF 3 SOLIDS	2/ 9/14/	0/3/0	CLEAR	1.0000	0.8621	0.8333	0.8333	0.8065	0.6667	0.6024	0.5814
491	3RD OF 3 SOLIDS	2/11/14/	0/3/0	CLEAR	1.0000	0.9091	0.8929	0.7937	0.8065	0.5747	0.5000	0.4950
37	1ST OF 4 SOLIDS	2/ 5/15/	0/3/0	CLEAR	0.0000	0.0000	0.0000	0.0000	0.0000	0.0000	0.0000	0.7042
37	2ND OF 4 SOLIDS	1/ 3/ 4/	1/1/0	CLEAR	1.1628	1.1628	1.0638	0.8929	0.7042	0.7143	0.6494	0.6667
37	3RD OF 4 SOLIDS	1/ 5/ 4/	1/1/0	CLEAR	1.1628	1.1628	1.0638	0.8929	0.7042	0.7143	0.6494	0.6667
37	4TH OF 4 SOLIDS	1/ 0/ 0/	0/22/1/0	CLEAR	1.1628	1.1628	1.0638	0.8929	0.7042	0.7143	0.6494	0.6667
43	1ST OF 4 SOLIDS	1/ 0/ 0/	0/23/2/0	CLEAR	1.0638	1.0204	0.9091	1.0417	1.1111	0.8621	0.8929	0.7813
43	2ND OF 4 SOLIDS	1/ 4/ 6/	1/2/0	CLEAR	1.1111	1.0638	0.9259	0.9259	0.8929	0.7246	0.8197	0.3937
43	3RD OF 4 SOLIDS	1/ 4/ 6/	1/2/0	CLEAR	1.1111	1.0417	0.8333	0.7143	0.6173	0.3731	0.6250	0.5051
43	4TH OF 4 SOLIDS	1/ 7/ 6/	1/2/0	9.245	1.1111	1.0870	0.9615	1.0000	0.6410	0.3356	0.0000	0.0000
45	1ST OF 4 SOLIDS	1/ 7/ 6/	1/2/0	9.805	0.0000	0.0000	0.0000	0.0000	0.0000	0.0000	0.0000	0.0000
45	2ND OF 4 SOLIDS	1/ 2/ 4/	1/1/0	9.695	0.0000	0.0000	0.0000	0.0000	0.0000	0.0000	0.0000	0.0000
45	3RD OF 4 SOLIDS	1/ 2/ 4/	1/1/0	9.665	0.0000	0.0000	0.0000	0.0000	0.0000	0.0000	0.0000	0.0000
45	4TH OF 4 SOLIDS	1/ 5/ 6/	1/2/0	9.585	0.9615	0.8621	0.7576	0.6757	0.7443	0.5495	0.0000	0.0000
48	1ST OF 4 SOLIDS	1/ 0/ 0/	0/16/1/0	CLEAR	0.9804	0.9615	0.8772	0.8333	0.7143	0.7692	0.7813	0.6410
48	2ND OF 4 SOLIDS	1/ 0/ 0/	0/16/1/0	CLEAR	0.9804	1.0000	0.8621	0.8197	0.8621	0.6944	0.5952	0.5682
48	3RD OF 4 SOLIDS	1/ 4/ 3/	1/1/0	CLEAR	0.9091	0.8621	0.8065	0.8333	0.8065	0.6098	0.5814	0.5319
48	4TH OF 4 SOLIDS	2/11/14/	0/3/0	CLEAR	0.8621	0.9091	0.6494	0.5952	0.4902	0.2747	0.1608	0.1938
85	1ST OF 4 SOLIDS	1/ 4/ 4/	1/2/0	CLEAR	1.0417	1.1111	0.8621	0.7692	0.7576	0.6410	0.7042	0.6098
85	2ND OF 4 SOLIDS	1/ 2/ 4/	1/2/0	CLEAR	1.0417	1.1111	0.8621	0.7692	0.7576	0.6410	0.7042	0.6098
85	3RD OF 4 SOLIDS	1/ 5/ 4/	1/2/0	CLEAR	1.0417	1.1111	0.8621	0.7692	0.7576	0.6410	0.7042	0.6098
85	4TH OF 4 SOLIDS	2/ 5/15/	0/3/0	CLEAR	0.9091	0.7463	0.7353	0.6757	0.5814	0.3371	0.2976	0.2778
89	1ST OF 4 SOLIDS	1/ 5/ 6/	1/2/0	CLEAR	0.0000	0.0000	0.0000	0.0000	0.0000	0.0000	0.0000	0.2000
89	2ND OF 4 SOLIDS	2/12/14/	0/3/0	CLEAR	0.0000	0.0000	0.0000	0.0000	0.0000	0.4950	0.2326	0.2049
89	3RD OF 4 SOLIDS	1/ 0/ 0/	0/30/1/0	CLEAR	1.2500	0.8929	0.9091	0.6579	0.5618	0.4464	0.2252	0.2165
89	4TH OF 4 SOLIDS	2/11/15/	0/3/0	CLEAR	0.9804	0.7692	0.6944	0.5882	0.4673	0.2773	0.2730	0.2809

102	1ST OF 4 SOLIDS	7/16/14/ 0/0/0	CLEAR	0.9804	0.8621	0.9804	0.8475	0.9091	0.9615	0.7576	0.7042	0.7463
102	2ND OF 4 SOLIDS	2/ 9/14/ 0/3/0	CLEAR	0.9091	0.8929	0.9091	0.8621	0.7576	0.6757	0.4834	0.4032	0.2825
102	3RD OF 4 SOLIDS	2/ 6/14/ 0/3/0	CLEAR	0.8929	0.8929	0.8929	0.8065	0.7042	0.6098	0.3906	0.2841	0.3311
102	4TH OF 4 SOLIDS	2/ 6/14/ 0/3/0	CLEAR	0.9459	0.9091	0.8065	0.7353	0.6329	0.5435	0.3401	0.3145	0.3676
119	1ST OF 4 SOLIDS	1/ 4/ 4/ 1/2/0	CLEAR	1.0417	1.1111	0.8621	0.6944	0.7692	0.7576	0.6410	0.7062	0.6098
119	2ND OF 4 SOLIDS	1/ 4/ 4/ 1/2/0	CLEAR	1.0417	1.1111	0.8621	0.6944	0.7692	0.7576	0.6410	0.7062	0.6098
119	3RD OF 4 SOLIDS	2/ 9/14/ 0/5/0	9.075	0.8621	0.7463	0.7463	0.6667	0.3731	0.2041	0.0000	0.0000	0.0000
119	4TH OF 4 SOLIDS	2/ 7/14/ 0/3/0	8.565	0.7813	0.7353	0.7463	0.5102	0.3226	0.1873	0.0000	0.0000	0.0000
132	1ST OF 4 SOLIDS	2/ 7/14/ 0/5/0	CLEAR	0.0000	0.0000	0.0000	0.0000	0.0000	0.0000	0.0000	0.5618	0.5051
132	2ND OF 4 SOLIDS	2/ 7/14/ 0/5/0	CLEAR	0.0000	0.0000	0.0000	0.0000	0.0000	0.0000	0.4167	0.5556	0.5000
132	3RD OF 4 SOLIDS	2/ 9/14/ 0/3/0	CLEAR	1.241	0.9259	0.9259	0.7937	0.7813	0.7576	0.5051	0.5319	0.5155
132	4TH OF 4 SOLIDS	2/ 7/14/ 0/5/0	CLEAR	0.9806	0.8929	0.8621	0.8772	0.7692	0.7143	0.4310	0.5000	0.5155
164	1ST OF 4 SOLIDS	1/ 4/ 6/ 1/2/0	CLEAR	0.9015	0.8333	0.7143	0.6250	0.5556	0.5263	0.4000	0.5000	0.5000
164	2ND OF 4 SOLIDS	1/ 4/ 6/ 1/2/0	CLEAR	0.9434	0.7353	0.6494	0.5882	0.5263	0.5000	0.3704	0.4762	0.4762
164	3RD OF 4 SOLIDS	1/ 4/ 6/ 1/2/0	CLEAR	0.9091	0.7143	0.6250	0.5263	0.4762	0.4545	0.3571	0.4348	0.4348
164	4TH OF 4 SOLIDS	1/ 4/ 6/ 1/2/0	CLEAR	0.8929	0.7042	0.6098	0.4902	0.4505	0.4386	0.3106	0.4098	0.4065
166	1ST OF 4 SOLIDS	1/ 4/ 0/ 1/2/0	CLEAR	0.9804	0.9434	0.7463	0.7042	0.7813	0.9434	0.6410	0.6579	0.5000
166	2ND OF 4 SOLIDS	1/ 2/ 4/ 1/2/0	8.335	0.9804	0.9434	0.7042	0.7143	0.6250	0.5556	0.0000	0.0000	0.0000
166	3RD OF 4 SOLIDS	5/11/15/30/5/4	5.955	1.2821	1.0000	0.5556	0.0000	0.0000	0.0000	0.0000	0.0000	0.0000
166	4TH OF 4 SOLIDS	2/ 7/16/ 0/5/0	4.285	0.9091	0.5102	0.0000	0.0000	0.0000	0.0000	0.0000	0.0000	0.0000
188	1ST OF 4 SOLIDS	1/ 2/ 4/ 1/1/0	CLEAR	1.2500	1.1628	1.0204	0.9091	0.7692	0.8772	0.7813	0.8475	0.7353
188	2ND OF 4 SOLIDS	1/ 0/ 0/22/1/0	CLEAR	0.8929	0.9091	0.9091	0.9091	0.8333	0.8929	0.7353	0.7042	0.6494
188	3RD OF 4 SOLIDS	1/ 4/ 5/ 1/1/0	CLEAR	0.8621	0.8772	0.9434	0.9091	0.8621	0.7937	0.6250	0.4545	0.3497
188	4TH OF 4 SOLIDS	2/ 9/15/ 0/5/0	CLEAR	0.7937	0.6849	0.6757	0.4587	0.2857	0.2857	0.2222	0.1818	0.1953
192	1ST OF 4 SOLIDS	1/ 0/ 0/30/1/0	CLEAR	1.0638	1.0638	0.9804	1.0204	0.7937	0.8929	0.8065	0.7692	0.6757
192	2ND OF 4 SOLIDS	1/ 4/ 4/ 1/1/0	CLEAR	1.2500	0.9259	1.0417	1.0417	0.9804	0.8772	0.7246	0.9259	0.4808
192	3RD OF 4 SOLIDS	1/ 2/ 4/ 1/1/0	CLEAR	1.2500	0.9259	1.0417	1.0417	0.9804	0.8772	0.7246	0.9259	0.4808
192	4TH OF 4 SOLIDS	2/11/14/ 0/5/0	CLEAR	0.9459	0.8475	0.8621	0.8197	0.8065	0.7246	0.5556	0.5102	0.4505
205	1ST OF 4 SOLIDS	5/12/14/ 0/5/6	CLEAR	0.0000	0.0000	0.0000	0.0000	0.0000	0.0000	0.0000	0.0000	0.0000
205	2ND OF 4 SOLIDS	2/10/14/ 0/3/0	CLEAR	0.0000	0.0000	0.0000	0.0000	0.0000	0.0000	0.0000	0.4717	0.4673
205	3RD OF 4 SOLIDS	2/ 4/14/ 0/3/0	CLEAR	0.0000	0.0000	0.0000	0.0000	0.0000	0.0000	0.0000	0.4717	0.4673
205	4TH OF 4 SOLIDS	2/ 7/14/ 0/3/0	CLEAR	1.4706	1.2195	0.9091	0.8065	0.8333	0.7692	0.6024	0.4808	0.4167
248	1ST OF 4 SOLIDS	1/ 3/ 5/ 1/2/0	CLEAR	1.0417	0.8929	0.9259	0.8065	0.7576	0.7813	0.6667	0.6494	0.6173
248	2ND OF 4 SOLIDS	1/ 2/ 4/ 1/2/0	CLEAR	0.9615	0.9259	0.9634	0.7937	0.7353	0.7246	0.6757	0.5747	0.4808
248	3RD OF 4 SOLIDS	1/ 3/ 5/ 1/2/0	9.605	0.8929	0.8929	0.8065	0.7576	0.6757	0.5682	0.1650	0.0000	0.0000
248	4TH OF 4 SOLIDS	2/ 9/14/ 0/3/0	9.265	0.8475	0.7813	0.7937	0.6667	0.4202	0.3145	0.2618	0.0000	0.0000
253	1ST OF 4 SOLIDS	1/ 4/ 4/ 1/2/0	CLEAR	1.0000	0.9259	0.9091	0.8929	0.7937	0.8197	0.6757	0.6410	0.6024
253	2ND OF 4 SOLIDS	1/ 5/ 4/ 1/2/0	CLEAR	1.0000	0.9434	0.9259	0.8929	0.7692	0.7937	0.6250	0.5618	0.5435
253	3RD OF 4 SOLIDS	1/ 7/ 4/ 1/2/0	9.295	1.0000	0.9091	0.8621	0.8197	0.7576	0.5208	0.3472	0.0000	0.0000
253	4TH OF 4 SOLIDS	2/11/15/ 0/5/0	3.615	0.6250	0.0000	0.0000	0.0000	0.0000	0.0000	0.0000	0.0000	0.0000
260	1ST OF 4 SOLIDS	6/ 0/ 0/ 0/0/0	CLEAR	0.0000	0.0000	0.0000	0.0000	0.0000	0.4167	0.5155	0.3571	0.2222
260	2ND OF 4 SOLIDS	1/ 0/ 0/1/1/1/0	CLEAR	1.0870	0.9804	1.0000	0.8772	0.7576	0.8197	0.7042	0.7937	0.7576
260	3RD OF 4 SOLIDS	1/ 4/ 5/ 1/1/0	CLEAR	0.8929	0.9259	0.9091	0.9091	0.7692	0.7143	0.4902	0.3906	0.2778
260	4TH OF 4 SOLIDS	2/ 9/14/ 0/3/0	CLEAR	0.9434	0.8772	0.9091	0.7463	0.6849	0.6098	0.3846	0.3203	0.3378
269	1ST OF 4 SOLIDS	2/ 5/14/ 0/3/0	CLEAR	0.9615	0.8475	0.7813	0.7692	0.6849	0.4664	0.1263	0.0866	0.0160
269	2ND OF 4 SOLIDS	1/ 7/ 8/ 1/2/0	CLEAR	0.9615	0.8475	0.7813	0.7692	0.6849	0.4664	0.1263	0.0866	0.0160
269	3RD OF 4 SOLIDS	1/ 5/ 6/ 1/2/0	9.615	0.7576	0.7692	0.6849	0.3676	0.1538	0.1348	0.0570	0.0000	0.0000
269	4TH OF 4 SOLIDS	2/ 7/14/ 0/3/0	9.535	0.7576	0.7692	0.6849	0.3676	0.1538	0.1348	0.0570	0.0000	0.0000
290	1ST OF 4 SOLIDS	2/ 7/14/ 0/3/0	CLEAR	0.9804	0.7937	0.8772	0.8621	0.7813	0.7576	0.6024	0.5208	0.3472
290	2ND OF 4 SOLIDS	2/ 5/14/ 0/3/0	CLEAR	0.8333	0.8929	0.8197	0.8065	0.7576	0.7042	0.4854	0.3704	0.3521
290	3RD OF 4 SOLIDS	2/ 5/14/ 0/3/0	CLEAR	0.8197	0.8772	0.8197	0.7813	0.7463	0.6757	0.4587	0.3521	0.3571
290	4TH OF 4 SOLIDS	2/ 5/14/ 0/3/0	CLEAR	0.8772	0.8333	0.8333	0.7692	0.7246	0.6329	0.4968	0.3704	0.3676

310	1ST OF 4 SOLIDS	2/ 9/14/ 0/3/0	6.455	0.872	0.8197	0.6849	0.4717	0.0000	0.0000	0.0000	0.0000	0.0000	0.0000	0.0000	0.0000	0.0000	0.0000	0.0000	0.0000
310	2ND OF 4 SOLIDS	2/ 7/14/ 0/3/0	4.475	0.7553	0.5882	0.0000	0.0000	0.0000	0.0000	0.0000	0.0000	0.0000	0.0000	0.0000	0.0000	0.0000	0.0000	0.0000	0.0000
310	3RD OF 4 SOLIDS	2/ 7/14/ 0/3/0	4.275	0.6744	0.4762	0.0000	0.0000	0.0000	0.0000	0.0000	0.0000	0.0000	0.0000	0.0000	0.0000	0.0000	0.0000	0.0000	0.0000
310	4TH OF 4 SOLIDS	2/ 7/14/ 0/3/0	4.115	0.7143	0.0000	0.0000	0.0000	0.0000	0.0000	0.0000	0.0000	0.0000	0.0000	0.0000	0.0000	0.0000	0.0000	0.0000	0.0000
311	1ST OF 4 SOLIDS	2/ 9/14/ 0/3/0	CLEAR	0.0000	0.0000	0.0000	0.0000	0.0000	0.0000	0.0000	0.0000	0.0000	0.0000	0.0000	0.0000	0.0000	0.0000	0.0000	0.0000
311	2ND OF 4 SOLIDS	2/ 7/14/ 0/3/0	CLEAR	0.0000	0.0000	0.0000	0.6329	0.6494	0.6667	0.6024	0.6667	0.6024	0.6667	0.6024	0.6667	0.6024	0.6667	0.6024	0.6667
311	3RD OF 4 SOLIDS	2/ 7/14/ 0/3/0	CLEAR	0.0000	0.0000	0.0000	0.6667	0.6579	0.5747	0.6348	0.6579	0.5747	0.6348	0.6579	0.5747	0.6348	0.6579	0.5747	0.6348
311	4TH OF 4 SOLIDS	2/ 7/14/ 0/3/0	CLEAR	0.0000	0.0000	0.9615	0.6849	0.6329	0.6024	0.6024	0.6329	0.6024	0.6024	0.6329	0.6024	0.6024	0.6329	0.6024	0.6024
312	1ST OF 4 SOLIDS	1/ 0/ 0/30/1/0	CLEAR	0.9091	0.9259	1.1111	0.9804	0.8772	0.9804	0.9804	0.8772	0.9804	0.9804	0.8772	0.9804	0.9804	0.8772	0.9804	0.9804
312	2ND OF 4 SOLIDS	2/ 9/14/ 0/3/0	CLEAR	0.8021	0.7576	0.8621	0.7937	0.6173	0.6410	0.6410	0.6173	0.6410	0.6173	0.6410	0.6173	0.6410	0.6173	0.6410	0.6173
312	3RD OF 4 SOLIDS	2/ 9/14/ 0/3/0	CLEAR	0.8065	0.7692	0.8475	0.7576	0.6098	0.6667	0.3968	0.6667	0.3968	0.6667	0.3968	0.6667	0.3968	0.6667	0.3968	0.6667
312	4TH OF 4 SOLIDS	2/ 5/14/ 0/3/0	CLEAR	0.8772	0.8197	0.7813	0.7463	0.6579	0.5747	0.3866	0.6579	0.5747	0.3866	0.6579	0.5747	0.3866	0.6579	0.5747	0.3866
313	1ST OF 4 SOLIDS	1/ 0/ 0/22/1/0	CLEAR	1.4706	1.0417	0.9091	0.8772	0.8772	0.9091	0.9091	0.8772	0.9091	0.9091	0.8772	0.9091	0.9091	0.8772	0.9091	0.9091
313	2ND OF 4 SOLIDS	7/15/14/ 0/1/0	CLEAR	1.2500	0.9615	1.0870	0.8065	0.8772	1.0638	0.6757	0.8772	1.0638	0.6757	0.8772	1.0638	0.6757	0.8772	1.0638	0.6757
313	3RD OF 4 SOLIDS	2/ 9/14/ 0/3/0	CLEAR	0.9434	0.8333	0.7692	0.8197	0.7463	0.7143	0.4808	0.7463	0.7143	0.4808	0.7463	0.7143	0.4808	0.7463	0.7143	0.4808
313	4TH OF 4 SOLIDS	2/ 5/14/ 0/3/0	CLEAR	0.8729	0.8197	0.8065	0.7937	0.7692	0.6410	0.3759	0.7692	0.6410	0.3759	0.7692	0.6410	0.3759	0.7692	0.6410	0.3759
317	1ST OF 4 SOLIDS	2/13/16/ 0/4/0	CLEAR	0.0000	0.0000	0.0000	0.0000	0.0000	0.0000	0.0000	0.0000	0.0000	0.0000	0.0000	0.0000	0.0000	0.0000	0.0000	0.0000
317	2ND OF 4 SOLIDS	1/ 3/ 8/ 1/1/0	CLEAR	1.0204	0.7143	0.7353	0.6867	0.4717	0.7353	0.4902	0.6867	0.4717	0.7353	0.4902	0.6867	0.4717	0.7353	0.4902	0.6867
317	3RD OF 4 SOLIDS	1/ 0/ 0/30/1/0	CLEAR	0.8475	0.7246	0.7246	0.7353	0.4762	0.6173	0.3937	0.7353	0.6173	0.3937	0.7353	0.6173	0.3937	0.7353	0.6173	0.3937
317	4TH OF 4 SOLIDS	2/11/14/ 0/3/0	CLEAR	0.8729	0.7692	0.7143	0.6024	0.4202	0.3788	0.2825	0.6024	0.4202	0.3788	0.6024	0.4202	0.3788	0.6024	0.4202	0.3788
328	1ST OF 4 SOLIDS	1/ 4/ 6/ 1/2/0	CLEAR	1.0404	0.7576	0.8929	0.7813	0.7937	0.7576	0.4348	0.7937	0.7576	0.4348	0.7937	0.7576	0.4348	0.7937	0.7576	0.4348
328	2ND OF 4 SOLIDS	2/11/14/ 0/5/0	CLEAR	0.9015	0.9259	0.8929	0.7813	0.7692	0.7463	0.5319	0.7692	0.7463	0.5319	0.7692	0.7463	0.5319	0.7692	0.7463	0.5319
328	3RD OF 4 SOLIDS	1/ 4/ 6/ 1/2/0	CLEAR	0.8021	0.8333	0.8333	0.7813	0.6329	0.5618	0.4065	0.6329	0.5618	0.4065	0.6329	0.5618	0.4065	0.6329	0.5618	0.4065
328	4TH OF 4 SOLIDS	2/11/14/ 0/5/0	CLEAR	0.8533	0.8772	0.8333	0.7463	0.5952	0.5618	0.3968	0.7463	0.5952	0.5618	0.7463	0.5952	0.5618	0.7463	0.5952	0.5618
366	1ST OF 4 SOLIDS	1/ 2/ 4/ 1/1/0	CLEAR	1.0038	0.9091	1.3514	0.8065	1.0000	0.9259	0.7463	1.0000	0.9259	0.7463	1.0000	0.9259	0.7463	1.0000	0.9259	0.7463
366	2ND OF 4 SOLIDS	1/ 2/ 4/ 1/1/0	CLEAR	1.0038	0.9259	1.2195	0.8772	0.9615	0.8621	0.6757	0.9615	0.8621	0.6757	0.9615	0.8621	0.6757	0.9615	0.8621	0.6757
366	3RD OF 4 SOLIDS	1/ 2/ 4/ 1/1/0	CLEAR	1.0038	1.0417	0.9434	0.8929	0.9259	0.9091	0.5952	0.9259	0.9091	0.5952	0.9259	0.9091	0.5952	0.9259	0.9091	0.5952
366	4TH OF 4 SOLIDS	1/ 2/ 4/ 1/1/0	CLEAR	1.1111	0.9259	1.0204	0.9434	0.8772	0.9259	0.5000	0.8772	0.9259	0.5000	0.8772	0.9259	0.5000	0.8772	0.9259	0.5000
379	1ST OF 4 SOLIDS	1/ 9/ 4/ 1/1/0	CLEAR	1.1564	0.9259	0.8772	0.8197	0.7813	0.8333	0.6667	0.7813	0.8333	0.6667	0.7813	0.8333	0.6667	0.7813	0.8333	0.6667
379	2ND OF 4 SOLIDS	1/ 5/ 4/ 1/1/0	CLEAR	1.0417	0.8929	0.8475	0.8333	0.8772	0.8929	0.7143	0.8772	0.8929	0.7143	0.8772	0.8929	0.7143	0.8772	0.8929	0.7143
379	3RD OF 4 SOLIDS	1/ 2/ 4/ 1/1/0	CLEAR	0.9434	0.9259	0.8929	0.7937	0.8929	0.8475	0.7246	0.8929	0.8475	0.7246	0.8929	0.8475	0.7246	0.8929	0.8475	0.7246
379	4TH OF 4 SOLIDS	2/ 9/14/ 0/3/0	CLEAR	0.8729	0.7463	0.6173	0.3968	0.3125	0.3268	0.2404	0.3125	0.3268	0.2404	0.3125	0.3268	0.2404	0.3125	0.3268	0.2404
382	1ST OF 4 SOLIDS	1/ 3/ 6/ 1/2/0	8.965	1.0038	0.8621	0.7813	0.7463	0.5556	0.5635	0.0000	0.5556	0.5635	0.0000	0.5556	0.5635	0.0000	0.5556	0.5635	0.0000
382	2ND OF 4 SOLIDS	1/ 5/ 8/ 1/2/0	5.475	0.7013	0.5814	0.3205	0.0000	0.0000	0.0000	0.0000	0.0000	0.0000	0.0000	0.0000	0.0000	0.0000	0.0000	0.0000	0.0000
382	3RD OF 4 SOLIDS	2/ 5/16/ 0/5/0	5.365	0.7692	0.5814	0.2994	0.0000	0.0000	0.0000	0.0000	0.0000	0.0000	0.0000	0.0000	0.0000	0.0000	0.0000	0.0000	0.0000
382	4TH OF 4 SOLIDS	1/ 3/ 6/ 1/2/0	5.275	0.7576	0.5882	0.1825	0.0000	0.0000	0.0000	0.0000	0.0000	0.0000	0.0000	0.0000	0.0000	0.0000	0.0000	0.0000	0.0000
393	1ST OF 4 SOLIDS	1/ 2/ 4/ 1/1/0	CLEAR	1.0000	0.9434	0.9091	0.8475	0.8475	0.8929	0.8475	0.8475	0.8929	0.8475	0.8475	0.8929	0.8475	0.8475	0.8929	0.8475
393	2ND OF 4 SOLIDS	1/ 2/ 4/ 1/1/0	CLEAR	1.0000	0.9434	0.9091	1.0000	0.8475	0.8621	0.8475	0.8475	0.8621	0.8475	0.8475	0.8621	0.8475	0.8475	0.8621	0.8475
393	3RD OF 4 SOLIDS	1/ 2/ 4/ 1/1/0	CLEAR	1.0000	0.9434	0.9091	0.9259	0.8333	0.9091	0.8621	0.8333	0.9091	0.8621	0.8333	0.9091	0.8621	0.8333	0.9091	0.8621
393	4TH OF 4 SOLIDS	2/ 8/14/ 0/3/0	5.955	0.6757	0.4032	0.2347	0.0000	0.0000	0.0000	0.0000	0.0000	0.0000	0.0000	0.0000	0.0000	0.0000	0.0000	0.0000	0.0000
425	1ST OF 4 SOLIDS	1/ 4/ 4/ 1/1/0	CLEAR	1.0204	1.0870	1.0417	0.8772	0.8772	0.8772	0.6849	0.8772	0.6849	0.8772	0.6849	0.8772	0.6849	0.8772	0.6849	0.8772
425	2ND OF 4 SOLIDS	1/ 7/ 4/ 1/1/0	CLEAR	0.9434	0.9259	0.9804	0.8772	0.8065	0.7576	0.6494	0.8065	0.7576	0.6494	0.8065	0.7576	0.6494	0.8065	0.7576	0.6494
425	3RD OF 4 SOLIDS	1/ 2/ 4/ 1/1/0	CLEAR	0.8729	1.0638	1.0417	0.8333	0.8621	0.6250	0.6024	0.8621	0.6250	0.6024	0.8621	0.6250	0.6024	0.8621	0.6250	0.6024
425	4TH OF 4 SOLIDS	2/ 7/16/ 0/3/0	6.265	0.7463	0.7353	0.5319	0.1656	0.0000	0.0000	0.0000	0.0000	0.0000	0.0000	0.0000	0.0000	0.0000	0.0000	0.0000	0.0000
438	1ST OF 4 SOLIDS	2/ 9/16/ 0/5/0	CLEAR	0.0000	0.0000	0.0000	0.0000	0.0000	0.5051	0.5208	0.0000	0.5051	0.5208	0.0000	0.5051	0.5208	0.0000	0.5051	0.5208
438	2ND OF 4 SOLIDS	2/ 7/15/ 0/3/0	CLEAR	0.0000	0.0000	0.0000	0.0000	0.0000	0.4717	0.5747	0.0000	0.4717	0.5747	0.0000	0.4717	0.5747	0.0000	0.4717	0.5747
438	3RD OF 4 SOLIDS	2/ 7/14/ 0/3/0	CLEAR	0.9434	0.8621	0.9091	0.8197	0.6579	0.5952	0.4464	0.6579	0.5952	0.4464	0.6579	0.5952	0.4464	0.6579	0.5952	0.4464
438	4TH OF 4 SOLIDS	2/ 5/14/ 0/3/0	CLEAR	0.8772	0.8621	0.8621	0.7692	0.6410	0.5495	0.3704	0.7692	0.6410	0.5495	0.7692	0.6410	0.5495	0.7692	0.6410	0.5495
441	1ST OF 4 SOLIDS	2/11/14/ 0/5/0	CLEAR	0.0000	0.0000	0.0000	0.6410	0.5495	0.6849	0.4717	0.5495	0.6849	0.4717	0.5495	0.6849	0.4717	0.5495	0.6849	0.4717
441	2ND OF 4 SOLIDS	7/16/13/ 0/1/0	CLEAR	1.2500	0.8929	0.6944	0.6410	0.5952	0.6173	0.3759	0.6410	0.5952	0.6173	0.3759	0.6410	0.5952	0.6173	0.3759	0.6173
441	3RD OF 4 SOLIDS	6/11/14/ 0/3/0	CLEAR	0.8333	0.7463	0.7143	0.6849	0.5556	0.3817	0.1992	0.6849	0.5556	0.3817	0.1992	0.6849	0.5556	0.3817	0.1992	0.6849
441	4TH OF 4 SOLIDS	2/12/14/ 0/3/0	CLEAR	0.8065	0.7463	0.7692	0.6757	0.5200	0.3378	0.1712	0.6757	0.5200	0.3378	0.1712	0.6757	0.5200	0.3378	0.1712	0.6757
445	1ST OF 4 SOLIDS	1/ 4/ 5/ 1/2/0	CLEAR	0.0000	0.0000	0.0000	0.0000	0.0000	0.0000	0.0000	0.0000	0.0000	0.0000	0.0000	0.0000	0.0000	0.0000	0.0000	0.0000

94	3RD OF 5 SOLIDS	1/ 8/ 5/ 1/2/0	8.755	0.8333	0.8197	0.8621	0.6098	0.6579	0.5376	0.0000	0.0000	0.0000	0.0000	0.0000	0.0000	0.0000	0.0000	0.0000	0.0000
94	4TH OF 5 SOLIDS	2/ 7/15/ 0/3/0	8.365	0.8333	0.8621	0.7353	0.7246	0.6410	0.4545	0.0000	0.0000	0.0000	0.0000	0.0000	0.0000	0.0000	0.0000	0.0000	0.0000
94	5TH OF 5 SOLIDS	2/ 6/14/ 0/3/0	8.215	0.7246	0.7692	0.7463	0.6757	0.5495	0.2688	0.0000	0.0000	0.0000	0.0000	0.0000	0.0000	0.0000	0.0000	0.0000	0.0000
117	1ST OF 5 SOLIDS	2/11/14/ 0/5/0	CLEAR	0.8929	0.7692	0.8333	0.8197	0.6849	0.7353	0.5435	0.5102	0.3067	0.3067	0.3067	0.3067	0.3067	0.3067	0.3067	0.3067
117	2ND OF 5 SOLIDS	2/ 9/14/ 0/5/0	CLEAR	1.1405	0.7692	0.6667	0.7937	0.7143	0.6667	0.5031	0.3968	0.3086	0.3086	0.3086	0.3086	0.3086	0.3086	0.3086	0.3086
117	3RD OF 5 SOLIDS	1/ 6/ 5/ 1/2/0	CLEAR	1.0038	0.8065	0.6329	0.7692	0.6849	0.6849	0.4673	0.3650	0.3311	0.3311	0.3311	0.3311	0.3311	0.3311	0.3311	0.3311
117	4TH OF 5 SOLIDS	2/ 7/14/ 0/3/0	CLEAR	0.9259	0.7813	0.6849	0.7692	0.6579	0.6849	0.4586	0.3597	0.3311	0.3311	0.3311	0.3311	0.3311	0.3311	0.3311	0.3311
117	5TH OF 5 SOLIDS	2/ 7/14/ 0/5/0	CLEAR	0.8065	0.7692	0.6944	0.6944	0.7042	0.6410	0.4065	0.3623	0.3425	0.3425	0.3425	0.3425	0.3425	0.3425	0.3425	0.3425
245	1ST OF 5 SOLIDS	1/ 4/ 5/ 1/1/0	CLEAR	1.0038	1.0638	0.9804	1.0204	0.8772	0.7353	0.6410	0.7692	0.7576	0.7576	0.7576	0.7576	0.7576	0.7576	0.7576	0.7576
245	2ND OF 5 SOLIDS	1/ 5/ 5/ 1/1/0	CLEAR	1.0417	1.0417	0.9804	0.9804	0.8065	0.6667	0.6849	0.7042	0.4854	0.4854	0.4854	0.4854	0.4854	0.4854	0.4854	0.4854
245	3RD OF 5 SOLIDS	2/11/14/21/3/3	CLEAR	0.8772	0.9804	0.8621	0.7576	0.7692	0.7246	0.5102	0.4098	0.2994	0.2994	0.2994	0.2994	0.2994	0.2994	0.2994	0.2994
245	4TH OF 5 SOLIDS	1/ 0/ 0/21/1/0	CLEAR	0.8065	0.9259	0.7937	0.7937	0.7353	0.6579	0.4587	0.3906	0.2778	0.2778	0.2778	0.2778	0.2778	0.2778	0.2778	0.2778
245	5TH OF 5 SOLIDS	2/12/14/ 0/3/0	CLEAR	0.8475	0.8197	0.8929	0.8197	0.7042	0.6098	0.4505	0.3676	0.2976	0.2976	0.2976	0.2976	0.2976	0.2976	0.2976	0.2976
254	1ST OF 5 SOLIDS	1/ 7/ 4/ 1/2/0	9.295	0.0000	0.0000	0.0000	0.0000	0.0000	0.0000	0.0000	0.0000	0.0000	0.0000	0.0000	0.0000	0.0000	0.0000	0.0000	0.0000
254	2ND OF 5 SOLIDS	2/11/15/ 0/5/0	8.905	0.0000	0.0000	0.5814	0.5155	0.4505	0.4902	0.0000	0.0000	0.0000	0.0000	0.0000	0.0000	0.0000	0.0000	0.0000	0.0000
254	3RD OF 5 SOLIDS	1/ 0/ 0/30/1/0	8.765	0.8475	0.6024	0.6944	0.5376	0.4673	0.4630	0.0000	0.0000	0.0000	0.0000	0.0000	0.0000	0.0000	0.0000	0.0000	0.0000
254	4TH OF 5 SOLIDS	5/12/14/ 7/5/1	6.855	0.5618	0.5618	0.6410	0.5051	0.0000	0.0000	0.0000	0.0000	0.0000	0.0000	0.0000	0.0000	0.0000	0.0000	0.0000	0.0000
254	5TH OF 5 SOLIDS	2/ 9/14/ 0/3/0	3.665	0.5155	0.0000	0.0000	0.0000	0.0000	0.0000	0.0000	0.0000	0.0000	0.0000	0.0000	0.0000	0.0000	0.0000	0.0000	0.0000
258	1ST OF 5 SOLIDS	1/ 0/ 0/27/1/0	CLEAR	1.1364	0.9615	1.2500	0.8621	0.9259	1.0638	0.7813	0.6173	0.6849	0.6849	0.6849	0.6849	0.6849	0.6849	0.6849	0.6849
258	2ND OF 5 SOLIDS	1/ 5/ 5/ 1/1/0	CLEAR	0.9259	0.9804	1.0000	0.9434	0.8333	0.7937	0.6410	0.6667	0.6173	0.6173	0.6173	0.6173	0.6173	0.6173	0.6173	0.6173
258	3RD OF 5 SOLIDS	1/ 7/ 4/ 1/1/0	CLEAR	0.9434	0.9615	0.9259	0.9259	0.7353	0.7576	0.6494	0.5882	0.4587	0.4587	0.4587	0.4587	0.4587	0.4587	0.4587	0.4587
258	4TH OF 5 SOLIDS	1/ 7/ 5/ 1/1/0	CLEAR	0.9615	0.9091	0.8475	0.8065	0.7692	0.7353	0.5495	0.4854	0.4167	0.4167	0.4167	0.4167	0.4167	0.4167	0.4167	0.4167
258	5TH OF 5 SOLIDS	2/11/14/ 0/3/0	CLEAR	0.9804	0.8197	0.8333	0.7692	0.7463	0.6329	0.4587	0.4310	0.4167	0.4167	0.4167	0.4167	0.4167	0.4167	0.4167	0.4167
277	1ST OF 5 SOLIDS	1/ 0/ 0/11/1/0	CLEAR	1.1364	1.0417	0.9259	0.8333	0.8197	0.7692	0.7143	0.5618	0.6329	0.6329	0.6329	0.6329	0.6329	0.6329	0.6329	0.6329
277	2ND OF 5 SOLIDS	1/ 7/ 6/ 1/1/0	CLEAR	0.9259	1.0000	1.0000	0.9091	0.8621	0.8772	0.6757	0.6098	0.6250	0.6250	0.6250	0.6250	0.6250	0.6250	0.6250	0.6250
277	3RD OF 5 SOLIDS	1/ 5/ 6/ 1/1/0	CLEAR	0.8065	1.0638	0.9615	0.8772	0.8621	0.8333	0.6579	0.6250	0.6329	0.6329	0.6329	0.6329	0.6329	0.6329	0.6329	0.6329
277	4TH OF 5 SOLIDS	1/ 5/ 6/ 1/1/0	CLEAR	0.8772	0.9259	0.8772	0.9615	0.7937	0.7463	0.6579	0.6098	0.5618	0.5618	0.5618	0.5618	0.5618	0.5618	0.5618	0.5618
277	5TH OF 5 SOLIDS	2/ 9/15/ 0/5/0	CLEAR	0.8333	0.7937	0.7353	0.7143	0.5882	0.4348	0.2591	0.2874	0.2577	0.2577	0.2577	0.2577	0.2577	0.2577	0.2577	0.2577
283	1ST OF 5 SOLIDS	6/ 7/16/ 0/5/0	CLEAR	0.0000	0.0000	0.0000	0.0000	0.0000	0.0000	0.0000	0.0000	0.0000	0.0000	0.0000	0.0000	0.0000	0.0000	0.0000	0.0000
283	2ND OF 5 SOLIDS	6/11/14/ 0/3/0	CLEAR	0.0000	0.0000	0.0000	0.0000	0.0000	0.0000	0.0000	0.0000	0.0000	0.0000	0.0000	0.0000	0.0000	0.0000	0.0000	0.0000
283	3RD OF 5 SOLIDS	1/ 5/ 4/ 1/1/0	CLEAR	0.9615	0.9804	0.9434	0.8475	0.7692	0.6757	0.3876	0.3546	0.4717	0.4717	0.4717	0.4717	0.4717	0.4717	0.4717	0.4717
283	4TH OF 5 SOLIDS	1/ 4/ 4/ 1/1/0	CLEAR	0.9259	1.0204	0.8929	0.8197	0.8621	0.6250	0.3676	0.3247	0.6274	0.6274	0.6274	0.6274	0.6274	0.6274	0.6274	0.6274
283	5TH OF 5 SOLIDS	2/12/14/ 0/5/0	CLEAR	0.8772	0.7813	0.9091	0.8197	0.7042	0.6757	0.3937	0.2907	0.3165	0.3165	0.3165	0.3165	0.3165	0.3165	0.3165	0.3165
321	1ST OF 5 SOLIDS	2/ 7/14/ 0/3/0	CLEAR	0.9091	0.9615	0.9259	0.8333	0.8197	0.7692	0.6579	0.6098	0.5263	0.5263	0.5263	0.5263	0.5263	0.5263	0.5263	0.5263
321	2ND OF 5 SOLIDS	1/ 4/ 4/ 1/1/0	CLEAR	0.7692	0.9434	0.9259	0.8065	0.8065	0.7463	0.4902	0.4673	0.4310	0.4310	0.4310	0.4310	0.4310	0.4310	0.4310	0.4310
321	3RD OF 5 SOLIDS	1/ 0/ 0/27/1/0	CLEAR	0.8333	0.9091	0.8621	0.7813	0.7143	0.6667	0.5376	0.4673	0.4348	0.4348	0.4348	0.4348	0.4348	0.4348	0.4348	0.4348
321	4TH OF 5 SOLIDS	1/ 4/ 4/ 1/1/0	CLEAR	0.8333	0.8333	0.8065	0.7463	0.6173	0.5155	0.5376	0.4425	0.4348	0.4348	0.4348	0.4348	0.4348	0.4348	0.4348	0.4348
321	5TH OF 5 SOLIDS	1/ 4/ 4/ 1/1/0	CLEAR	0.8621	0.7246	0.7463	0.6173	0.5814	0.5155	0.2415	0.3401	0.2994	0.2994	0.2994	0.2994	0.2994	0.2994	0.2994	0.2994
341	1ST OF 5 SOLIDS	1/ 0/ 0/22/2/0	CLEAR	1.0638	0.9804	0.8197	0.6329	0.2042	0.8333	0.6410	0.5556	0.4902	0.4902	0.4902	0.4902	0.4902	0.4902	0.4902	0.4902
341	2ND OF 5 SOLIDS	1/ 4/ 6/ 1/2/0	9.375	0.8621	0.7937	0.8197	0.7463	0.7143	0.5635	0.2203	0.0000	0.0000	0.0000	0.0000	0.0000	0.0000	0.0000	0.0000	0.0000
341	3RD OF 5 SOLIDS	1/ 4/ 6/ 1/2/0	9.295	0.9091	0.8333	0.8065	0.7463	0.6849	0.5208	0.1538	0.0000	0.0000	0.0000	0.0000	0.0000	0.0000	0.0000	0.0000	0.0000
341	4TH OF 5 SOLIDS	2/ 9/14/ 0/5/0	9.225	0.7376	0.7813	0.7813	0.6667	0.5814	0.4386	0.0000	0.0000	0.0000	0.0000	0.0000	0.0000	0.0000	0.0000	0.0000	0.0000
341	5TH OF 5 SOLIDS	2/ 7/14/ 0/5/0	9.085	0.7937	0.7937	0.7692	0.6494	0.5319	0.3788	0.0000	0.0000	0.0000	0.0000	0.0000	0.0000	0.0000	0.0000	0.0000	0.0000
358	1ST OF 5 SOLIDS	1/ 0/ 0/21/1/0	CLEAR	0.9091	1.1905	1.1905	1.0417	0.9091	0.6494	0.7353	0.8065	0.6410	0.6410	0.6410	0.6410	0.6410	0.6410	0.6410	0.6410
358	2ND OF 5 SOLIDS	2/ 5/14/ 0/3/0	CLEAR	0.8772	0.9091	1.0000	0.9091	0.7692	0.7576	0.7062	0.6250	0.5319	0.5319	0.5319	0.5319	0.5319	0.5319	0.5319	0.5319
358	3RD OF 5 SOLIDS	2/ 5/14/ 0/3/0	CLEAR	0.9091	0.8929	1.0000	0.8065	0.7376	0.8065	0.6329	0.5747	0.4762	0.4762	0.4762	0.4762	0.4762	0.4762	0.4762	0.4762
358	4TH OF 5 SOLIDS	1/ 5/ 6/ 1/1/0	CLEAR	0.9091	0.9091	0.9259	0.7813	0.8065	0.7937	0.5747	0.5155	0.5102	0.5102	0.5102	0.5102	0.5102	0.5102	0.5102	0.5102
358	5TH OF 5 SOLIDS	2/ 5/14/ 0/3/0	CLEAR	0.8333	0.7813	0.9259	0.7937	0.6757	0.5747	0.3817	0.3472	0.3472	0.3472	0.3472	0.3472	0.3472	0.3472	0.3472	0.3472
388	1ST OF 5 SOLIDS	1/ 0/ 0/21/1/0	CLEAR	1.0417	1.1628	1.0870	0.8333	0.7813	0.8475	0.7353	0.7576	0.7143	0.7143	0.7143	0.7143	0.7143	0.7143	0.7143	0.7143
388	2ND OF 5 SOLIDS	7/13/16/ 0/1/0	CLEAR	1.1111	1.0000	0.9434	0.9804	0.6944	0.8621	0.7353	0.6944	0.7353	0.7353	0.7353	0.7353	0.7353	0.7353	0.7353	0.7353
388	3RD OF 5 SOLIDS	2/11/14/ 0/3/0	CLEAR	1.1111	1.0000	0.9434	0.9434	0.7143	0.7813	0.6250	0.6024	0.5155	0.5155	0.5155	0.5155	0.5155	0.5155	0.5155	0.5155
388	4TH OF 5 SOLIDS	7/13/16/ 0/1/0	CLEAR	1.1111	1.0000	0.9091	0.8929	0.7353	0.7692	0.6098	0.6098	0.6098	0.6098	0.6098	0.6098	0.6098	0.6098	0.6098	0.6098
388	5TH OF 5 SOLIDS	2/ 5/14/ 0/3/0	CLEAR	0.8772	0.8065	0.7463	0.6173	0.5682	0.5102	0.2874	0.3597	0.3597	0.3597	0.3597	0.3597	0.3597	0.3597	0.3597	0.3597
413	1ST OF 5 SOLIDS	1/ 0/ 0/30/1/0	CLEAR	1.1111	0.9091	0.8772	0.9091	0.7246	0.8772	0.6757	0.7692	0.7692	0.7692	0.7692	0.7692	0.7692	0.7692	0.7692	0.7692
413	2ND OF 5 SOLIDS	1/ 7/ 4/ 1/1/0	CLEAR	0.9804	0.9														

413	3RD OF 5 SOLIDS	1/ 2/ 4/ 1/1/0	CLEAR	0.9434	0.8333	0.9434	0.7353	0.7353	0.6667	0.5051	0.5747	0.5495
413	4TH OF 5 SOLIDS	5/11/14/23/5/3	CLEAR	0.9091	0.7692	0.8197	0.7937	0.6757	0.6944	0.5376	0.4098	0.3704
413	5TH OF 5 SOLIDS	2/ 5/14/ 0/3/0	CLEAR	1.0038	0.9091	0.8065	0.7813	0.6167	0.5376	0.4032	0.4202	0.3968
440	1ST OF 5 SOLIDS	1/ 2/ 4/ 1/1/0	CLEAR	0.9259	0.9091	1.0000	0.7246	0.7813	0.6944	0.6098	0.4950	0.3876
440	2ND OF 5 SOLIDS	1/ 7/ 5/ 1/1/0	CLEAR	0.9615	0.8621	0.8065	0.7937	0.7576	0.7143	0.6610	0.4762	0.3817
440	3RD OF 5 SOLIDS	1/ 5/ 5/ 1/1/0	CLEAR	0.8772	0.8065	0.7492	0.8065	0.7576	0.7246	0.6024	0.4717	0.3817
440	4TH OF 5 SOLIDS	1/ 2/ 5/ 1/1/0	CLEAR	0.7813	0.8333	0.7463	0.6849	0.7937	0.7246	0.6230	0.4310	0.3788
440	5TH OF 5 SOLIDS	2/11/14/ 0/5/0	4.335	0.7246	0.3597	0.0000	0.0000	0.0000	0.0000	0.0000	0.0000	0.0000
461	1ST OF 5 SOLIDS	1/ 2/ 2/ 1/2/0	CLEAR	1.4286	1.2195	1.1364	0.7692	0.7692	0.7463	0.6849	0.6757	0.6757
461	2ND OF 5 SOLIDS	1/ 7/ 6/ 1/2/0	CLEAR	1.7857	1.2195	1.1364	0.7576	0.7463	0.7143	0.6024	0.2688	0.1370
461	3RD OF 5 SOLIDS	1/ 3/ 8/ 1/2/0	10.995	0.8197	0.8065	0.7143	0.6854	0.3030	0.2326	0.1754	0.1333	0.0000
461	4TH OF 5 SOLIDS	2/ 9/14/ 0/3/0	10.945	0.8065	0.8065	0.6757	0.4717	0.2959	0.2326	0.1712	0.1330	0.0000
461	5TH OF 5 SOLIDS	2/ 9/14/ 0/3/0	7.425	0.7813	0.7813	0.5435	0.2024	0.1385	0.0000	0.0000	0.0000	0.0000
496	1ST OF 5 SOLIDS	1/ 3/ 4/ 1/1/0	CLEAR	1.1564	0.9804	1.0000	0.8772	0.7576	0.7042	0.7692	0.6849	0.6024
496	2ND OF 5 SOLIDS	1/ 2/ 4/ 1/1/0	CLEAR	1.0038	0.9434	0.9259	0.9615	0.7813	0.7246	0.7143	0.6757	0.6494
496	3RD OF 5 SOLIDS	1/ 5/ 4/ 1/1/0	CLEAR	0.9434	0.9804	0.9259	0.8065	0.9091	0.8475	0.6944	0.6849	0.6494
496	4TH OF 5 SOLIDS	1/ 2/ 4/ 1/1/0	CLEAR	0.8772	0.8475	1.0204	0.8065	1.0638	0.6250	0.6579	0.6494	0.6329
496	5TH OF 5 SOLIDS	2/11/14/ 0/3/0	CLEAR	0.7692	0.8929	0.8772	0.7692	0.6757	0.6329	0.4673	0.2976	0.2660
9	1ST OF 6 SOLIDS	2/ 5/14/ 0/3/0	CLEAR	1.0417	0.9091	0.9091	0.8621	0.7353	0.8197	0.6944	0.4950	0.4000
9	2ND OF 6 SOLIDS	1/ 3/ 6/ 1/2/0	CLEAR	0.8429	0.8772	0.8475	0.7813	0.7576	0.6667	0.5435	0.5102	0.4132
9	3RD OF 6 SOLIDS	1/ 7/ 6/ 1/2/0	CLEAR	0.8772	0.8333	0.8621	0.8333	0.6579	0.6410	0.4808	0.3937	0.3704
9	4TH OF 6 SOLIDS	2/ 7/14/ 0/3/0	CLEAR	0.8475	0.8621	0.8621	0.8065	0.6579	0.6329	0.4505	0.3704	0.3571
9	5TH OF 6 SOLIDS	2/ 5/14/ 0/3/0	CLEAR	0.8021	0.8772	0.7813	0.7937	0.6250	0.5747	0.3788	0.3676	0.3846
9	6TH OF 6 SOLIDS	2/ 7/14/ 0/3/0	CLEAR	0.8429	0.8929	0.7813	0.6944	0.6410	0.5618	0.3521	0.3423	0.3906
20	1ST OF 6 SOLIDS	1/ 0/ 0/ 4/1/0	CLEAR	0.9615	1.0638	0.9091	0.9804	0.7463	0.9259	0.5618	0.6757	0.5208
20	2ND OF 6 SOLIDS	1/ 4/ 5/ 1/1/0	CLEAR	0.9615	0.8772	0.8929	0.7463	0.8621	0.7246	0.6173	0.4950	0.3876
20	3RD OF 6 SOLIDS	1/ 4/ 5/ 1/1/0	CLEAR	0.9615	0.8475	0.9434	0.7813	0.8621	0.8475	0.6024	0.4854	0.3650
20	4TH OF 6 SOLIDS	1/ 4/ 5/ 1/1/0	CLEAR	1.0070	0.9259	0.9434	0.7692	0.8197	0.8065	0.3747	0.4505	0.3676
20	5TH OF 6 SOLIDS	2/11/14/ 0/3/0	CLEAR	0.9615	0.9091	0.8197	0.7937	0.7937	0.7143	0.5435	0.4310	0.3106
20	6TH OF 6 SOLIDS	2/ 5/14/ 0/3/0	CLEAR	1.0000	0.7143	0.6667	0.5263	0.4717	0.4065	0.3571	0.4063	0.2155
29	1ST OF 6 SOLIDS	1/ 5/ 6/ 1/1/0	CLEAR	0.7437	1.0417	1.0204	1.0638	0.7463	0.7463	0.7576	0.6250	0.6024
29	2ND OF 6 SOLIDS	1/ 5/ 6/ 1/1/0	CLEAR	0.7692	0.9804	0.9615	1.0000	0.7937	0.7353	0.7576	0.6250	0.5882
29	3RD OF 6 SOLIDS	1/ 5/ 6/ 1/1/0	CLEAR	0.8621	0.8475	0.8475	0.9091	0.7813	0.7443	0.6173	0.4673	0.4545
29	4TH OF 6 SOLIDS	1/ 5/ 6/ 1/1/0	CLEAR	0.8621	0.8475	0.8333	0.8621	0.7813	0.7042	0.5495	0.4425	0.4762
29	5TH OF 6 SOLIDS	1/ 2/ 4/ 1/1/0	CLEAR	0.8621	0.8475	0.8197	0.8065	0.7937	0.6494	0.5263	0.4587	0.4505
29	6TH OF 6 SOLIDS	2/ 7/14/ 0/3/0	CLEAR	0.8621	0.8475	0.8197	0.8065	0.7937	0.6494	0.5263	0.4587	0.4505
57	1ST OF 6 SOLIDS	1/ 9/ 6/ 1/2/0	CLEAR	0.0000	0.0000	0.0000	0.0000	0.0000	0.0000	0.0000	0.0000	0.1792
57	2ND OF 6 SOLIDS	2/ 9/13/ 0/3/0	CLEAR	0.0000	0.0000	0.0000	0.0000	0.0000	0.0000	0.0000	0.0000	0.1792
57	3RD OF 6 SOLIDS	2/ 9/14/ 0/3/0	CLEAR	0.0000	0.0000	0.0000	0.0000	0.0000	0.0000	0.0000	0.0000	0.1792
57	4TH OF 6 SOLIDS	2/ 9/15/ 0/3/0	CLEAR	1.0204	0.8772	0.7813	0.6944	0.7143	0.6667	0.5682	0.2463	0.1613
57	5TH OF 6 SOLIDS	2/ 5/15/ 0/3/0	CLEAR	0.9091	0.7937	0.8197	0.7042	0.6494	0.5952	0.2994	0.2049	0.2370
57	6TH OF 6 SOLIDS	2/ 4/14/ 0/3/0	CLEAR	0.7463	0.6494	0.5102	0.4202	0.6237	0.3286	0.2024	0.2041	0.3268
125	1ST OF 6 SOLIDS	1/ 4/ 6/ 1/1/0	CLEAR	1.0417	0.8621	0.7576	0.8333	0.7813	0.7937	0.6667	0.6379	0.5319
125	2ND OF 6 SOLIDS	1/ 2/ 6/ 1/2/0	CLEAR	0.9434	0.7937	0.8772	0.7937	0.7692	0.8772	0.5882	0.6173	0.4854
125	3RD OF 6 SOLIDS	1/ 2/ 6/ 1/1/0	CLEAR	0.9434	0.8333	0.8475	0.8333	0.7463	0.7937	0.6173	0.5952	0.5000
125	4TH OF 6 SOLIDS	1/ 5/ 6/ 1/1/0	CLEAR	0.8333	0.8772	0.8333	0.8333	0.7937	0.7463	0.5618	0.4902	0.4464
125	5TH OF 6 SOLIDS	1/ 2/ 4/ 1/1/0	CLEAR	0.9804	0.9434	0.8621	0.8333	0.7937	0.7692	0.5319	0.4762	0.4000
125	6TH OF 6 SOLIDS	2/ 7/14/ 0/3/0	CLEAR	0.5000	0.4808	0.4545	0.3788	0.4032	0.3597	0.2577	0.3226	0.3448
145	1ST OF 6 SOLIDS	1/ 5/ 4/ 1/1/0	CLEAR	1.1564	0.9434	0.8772	0.8772	0.9615	0.9434	0.6494	0.6173	0.7042
145	2ND OF 6 SOLIDS	1/ 2/ 2/ 1/1/0	CLEAR	1.0204	0.9434	0.9091	0.9434	0.9259	0.8621	0.6944	0.6494	0.6849
145	3RD OF 6 SOLIDS	1/ 5/ 4/ 1/1/0	CLEAR	0.9434	0.9804	1.0204	0.9615	0.8621	0.7937	0.6757	0.6757	0.6667
145	4TH OF 6 SOLIDS	1/ 2/ 4/ 1/1/0	CLEAR	0.9804	0.9804	1.0204	0.9434	0.8197	0.8475	0.7042	0.6757	0.6579
145	5TH OF 6 SOLIDS	1/ 4/ 4/ 1/1/0	CLEAR	0.9615	1.0000	1.0204	0.8929	0.8333	0.8621	0.7042	0.6849	0.6579
145	6TH OF 6 SOLIDS	2/ 7/14/ 0/3/0	CLEAR	0.9804	0.8772	0.8675	0.8197	0.7692	0.7143	0.5618	0.4386	0.3401
224	1ST OF 6 SOLIDS	1/ 3/ 5/ 1/2/0	CLEAR	1.0038	1.1628	1.0617	0.7813	0.7692	0.8621	0.6667	0.7042	0.6579
224	2ND OF 6 SOLIDS	1/ 5/ 5/ 1/2/0	CLEAR	1.0204	1.1111	0.9434	0.8333	0.8475	0.8475	0.6579	0.7143	0.6667

224	3RD OF 6 SOLIDS	1/ 5/ 5/ 1/2/0	CLEAR	1.0417	1.0417	0.9434	0.8197	0.8621	0.8065	0.6579	0.7143	0.7042
224	4TH OF 6 SOLIDS	1/ 2/ 4/ 1/2/0	CLEAR	1.0000	0.9615	0.9434	0.8475	0.8065	0.8333	0.6579	0.7143	0.6579
226	5TH OF 6 SOLIDS	1/ 9/ 5/ 1/2/0	CLEAR	0.9615	0.8929	0.9259	0.8621	0.7692	0.8065	0.6667	0.6944	0.6098
226	6TH OF 6 SOLIDS	2/ 11/ 14/ 0/3/0	CLEAR	0.9259	0.8065	0.8621	0.7813	0.7576	0.6494	0.5263	0.3759	0.3185
243	1ST OF 6 SOLIDS	1/ 5/ 4/ 1/2/0	CLEAR	1.1111	1.0638	1.0417	0.9091	0.7576	0.7143	0.6667	0.5882	0.2222
243	2ND OF 6 SOLIDS	1/ 5/ 4/ 1/2/0	CLEAR	1.0638	1.0638	0.9804	0.7813	0.6579	0.5682	0.6250	0.3448	0.2747
243	3RD OF 6 SOLIDS	1/ 5/ 4/ 1/2/0	CLEAR	1.0638	1.0638	0.9804	0.7813	0.6579	0.5682	0.6250	0.3448	0.2747
243	4TH OF 6 SOLIDS	1/ 7/ 5/ 1/2/0	9.675	0.9091	0.7813	0.8475	0.7246	0.6849	0.6667	0.3378	0.0000	0.0000
243	5TH OF 6 SOLIDS	2/ 11/ 14/ 0/3/0	9.565	0.8475	0.8197	0.8475	0.6849	0.7353	0.6250	0.2232	0.0000	0.0000
243	6TH OF 6 SOLIDS	2/ 5/ 14/ 0/3/0	8.365	0.7576	0.5495	0.4717	0.3401	0.2604	0.1316	0.0000	0.0000	0.0000
252	1ST OF 6 SOLIDS	1/ 3/ 2/ 1/2/0	CLEAR	0.8621	0.8333	0.8772	0.7042	0.6757	0.3676	0.4167	0.4000	0.5155
252	2ND OF 6 SOLIDS	1/ 4/ 6/ 1/2/0	CLEAR	0.8475	0.8333	0.8621	0.6579	0.6329	0.3546	0.4098	0.4310	0.4717
252	3RD OF 6 SOLIDS	1/ 0/ 0/21/2/0	CLEAR	0.8621	0.8333	0.8772	0.6494	0.6250	0.3226	0.4368	0.4464	0.4762
252	4TH OF 6 SOLIDS	1/ 4/ 6/ 1/2/0	8.995	0.7463	0.7246	0.4587	0.2890	0.2304	0.2110	0.0000	0.0000	0.0000
252	5TH OF 6 SOLIDS	1/ 4/ 6/ 1/2/0	8.905	0.7813	0.6579	0.4673	0.2809	0.2304	0.2075	0.0000	0.0000	0.0000
252	6TH OF 6 SOLIDS	2/ 7/ 14/ 0/3/0	8.045	0.4065	0.3650	0.2976	0.2315	0.1567	0.0000	0.0000	0.0000	0.0000
255	1ST OF 6 SOLIDS	1/ 7/ 4/ 1/2/0	CLEAR	0.0000	0.0000	0.0000	0.0000	0.0000	0.0000	0.0000	0.0000	0.1761
255	2ND OF 6 SOLIDS	2/ 11/ 15/ 0/3/0	CLEAR	0.0000	0.0000	0.0000	0.0000	0.0000	0.0000	0.0000	0.0000	0.1742
255	3RD OF 6 SOLIDS	1/ 0/ 0/30/1/0	CLEAR	0.0000	0.0000	0.0000	0.0000	0.0000	0.0000	0.0000	0.2119	0.1730
255	4TH OF 6 SOLIDS	5/ 12/ 14/ 7/5/1	CLEAR	0.0000	0.0000	0.0000	0.0000	0.0000	0.6849	0.2857	0.2203	0.1712
255	5TH OF 6 SOLIDS	2/ 9/ 14/ 0/3/0	CLEAR	0.0000	0.0000	0.8333	0.8065	0.4762	0.5952	0.2747	0.2119	0.1724
255	6TH OF 6 SOLIDS	2/ 11/ 14/ 0/3/0	11.195	0.8621	0.7042	0.6494	0.5155	0.4600	0.2959	0.1859	0.1362	0.1282
271	1ST OF 6 SOLIDS	1/ 2/ 4/ 1/2/0	CLEAR	0.9615	1.1628	1.1905	0.9259	0.7576	0.9259	0.7937	0.7463	0.7692
271	2ND OF 6 SOLIDS	1/ 2/ 4/ 1/2/0	CLEAR	0.8621	1.1628	1.1628	0.9434	0.7692	0.7692	0.7692	0.7576	0.7463
271	3RD OF 6 SOLIDS	1/ 5/ 5/ 1/1/0	CLEAR	0.8333	0.9434	1.0417	0.9615	0.8621	0.7813	0.6329	0.6410	0.6024
271	4TH OF 6 SOLIDS	1/ 2/ 4/ 1/1/0	CLEAR	0.7813	0.8929	1.0000	0.8929	0.8197	0.8475	0.6098	0.6098	0.6173
271	5TH OF 6 SOLIDS	1/ 2/ 4/ 1/1/0	CLEAR	0.8197	0.8475	1.0204	0.7937	0.8333	0.7353	0.5952	0.5556	0.5618
271	6TH OF 6 SOLIDS	2/ 7/ 14/ 0/3/0	CLEAR	0.9259	0.8475	0.8929	0.7937	0.7692	0.7042	0.4854	0.4202	0.2222
274	1ST OF 6 SOLIDS	2/ 13/ 13/ 0/3/0	CLEAR	0.0000	0.0000	0.0000	0.0000	0.0000	0.0000	0.0000	0.5155	0.4673
274	2ND OF 6 SOLIDS	2/ 7/ 14/ 0/3/0	CLEAR	0.0000	0.0000	0.0000	0.0000	0.0000	0.0000	0.0000	0.5051	0.4425
274	3RD OF 6 SOLIDS	1/ 0/ 0/30/1/0	CLEAR	1.0000	1.0000	0.9615	0.8929	0.7663	0.6098	0.4098	0.4950	0.4505
274	4TH OF 6 SOLIDS	1/ 5/ 6/ 1/1/0	CLEAR	0.8929	0.8621	0.9434	1.0000	0.6329	0.6098	0.3817	0.3378	0.2538
274	5TH OF 6 SOLIDS	2/ 7/ 14/ 0/3/0	CLEAR	0.8475	0.8333	0.8475	0.8197	0.7143	0.6379	0.3706	0.2907	0.2890
274	6TH OF 6 SOLIDS	2/ 5/ 14/ 0/3/0	CLEAR	0.8333	0.8333	0.8065	0.8065	0.7353	0.5556	0.3226	0.2994	0.3165
314	1ST OF 6 SOLIDS	1/ 2/ 4/ 1/2/0	CLEAR	1.2621	0.9259	0.8333	0.8772	0.7143	0.7692	0.6849	0.6757	0.5814
314	2ND OF 6 SOLIDS	1/ 2/ 4/ 1/2/0	CLEAR	1.1628	0.8333	0.8772	0.7813	0.7576	0.7353	0.6329	0.5747	0.6024
314	3RD OF 6 SOLIDS	1/ 2/ 4/ 1/2/0	CLEAR	1.0638	0.7937	0.7813	0.7937	0.8197	0.7692	0.5952	0.5376	0.4348
314	4TH OF 6 SOLIDS	1/ 7/ 6/ 1/2/0	9.515	1.1111	0.7353	0.7937	0.7463	0.7042	0.6024	0.3906	0.0000	0.0000
314	5TH OF 6 SOLIDS	2/ 11/ 14/ 0/3/0	9.415	1.0638	0.6944	0.8333	0.7576	0.7143	0.5682	0.3378	0.0000	0.0000
314	6TH OF 6 SOLIDS	2/ 5/ 14/ 0/3/0	8.985	0.9615	0.6944	0.7042	0.5814	0.5000	0.4386	0.0000	0.0000	0.0000
322	1ST OF 6 SOLIDS	1/ 4/ 6/ 1/1/0	CLEAR	1.1111	1.0417	1.0000	0.8333	0.7937	0.7353	0.6098	0.5633	0.6329
322	2ND OF 6 SOLIDS	1/ 4/ 6/ 1/1/0	CLEAR	1.0870	1.0204	1.1364	0.8197	0.7463	0.7143	0.6098	0.4587	0.6944
322	3RD OF 6 SOLIDS	1/ 0/ 0/21/1/0	CLEAR	1.0638	0.9259	1.3158	0.7937	0.7692	0.7463	0.4762	0.4762	0.5618
322	4TH OF 6 SOLIDS	2/ 13/ 14/ 0/3/0	CLEAR	1.0638	0.9259	0.8772	0.7143	0.7937	0.7463	0.5000	0.4425	0.2415
322	5TH OF 6 SOLIDS	2/ 9/ 14/ 2/3/3	CLEAR	1.2500	0.7937	0.8197	0.7813	0.7246	0.7692	0.5682	0.3333	0.2128
322	6TH OF 6 SOLIDS	2/ 5/ 14/ 0/3/0	CLEAR	0.4205	0.4065	0.4808	0.3185	0.2632	0.2762	0.2564	0.2273	0.2222
347	1ST OF 6 SOLIDS	5/ 7/ 14/ 2/3/3	CLEAR	0.0000	0.0000	0.0000	0.0000	0.5882	0.6098	0.3472	0.1506	0.1136
347	2ND OF 6 SOLIDS	2/ 9/ 14/ 0/3/0	10.345	0.0000	0.0000	0.0000	0.0000	0.6173	0.5882	0.3311	0.1220	0.0000
347	3RD OF 6 SOLIDS	2/ 13/ 14/ 0/3/0	10.175	0.0000	0.0000	0.0000	0.5102	0.6250	0.5814	0.3165	0.1082	0.0000
347	4TH OF 6 SOLIDS	2/ 9/ 15/ 0/3/0	9.965	0.0000	0.0000	0.0000	0.5051	0.6173	0.5319	0.2315	0.0000	0.0000
347	5TH OF 6 SOLIDS	2/ 6/ 14/ 0/3/0	9.805	0.9615	0.8929	0.6579	0.5102	0.6098	0.5051	0.2137	0.0000	0.0000
347	6TH OF 6 SOLIDS	2/ 6/ 14/ 0/3/0	9.715	0.9259	0.9091	0.5952	0.5618	0.5952	0.5000	0.1786	0.0000	0.0000
349	1ST OF 6 SOLIDS	1/ 6/ 6/ 1/1/0	CLEAR	1.1628	1.0000	0.9615	0.7143	0.8333	0.7937	0.6529	0.5814	0.6024
349	2ND OF 6 SOLIDS	1/ 0/ 0/21/1/0	CLEAR	1.0417	0.8475	0.9804	0.8772	0.7692	0.7463	0.5882	0.6098	0.5435
349	3RD OF 6 SOLIDS	1/ 5/ 6/ 1/1/0	CLEAR	0.9091	0.8475	0.9091	0.8333	0.7576	0.6849	0.6024	0.6024	0.4950
349	4TH OF 6 SOLIDS	1/ 5/ 6/ 1/1/0	CLEAR	0.8929	0.8621	0.8333	0.7576	0.6849	0.6944	0.4854	0.3817	0.2294
349	5TH OF 6 SOLIDS	2/ 6/ 14/ 0/3/0	CLEAR	0.8929	0.8621	0.8475	0.8197	0.7463	0.6849	0.4098	0.4386	0.2155

349	6TH OF 6 SOLIDS	4/ 6/14/ 0/5/0	CLEAR	0.8333	0.7813	0.8065	0.6849	0.6250	0.5618	0.3817	0.3401	0.2674
354	1ST OF 6 SOLIDS	1/ 3/ 5/ 1/1/0	CLEAR	1.1364	1.0000	1.0000	0.9615	0.7937	0.7143	0.7042	0.7246	0.6944
354	2ND OF 6 SOLIDS	1/ 3/ 5/ 1/1/0	CLEAR	0.9259	1.0000	0.9434	0.7353	0.7937	0.7692	0.5952	0.5556	0.5155
354	3RD OF 6 SOLIDS	1/ 3/ 5/ 1/1/0	CLEAR	0.9091	0.8929	0.8333	0.7692	0.7246	0.7246	0.4808	0.4464	0.6173
354	4TH OF 6 SOLIDS	2/ 4/14/ 0/5/0	10.685	0.8929	0.7463	0.8929	0.6667	0.6173	0.1025	0.1179	0.1190	0.0000
354	5TH OF 6 SOLIDS	2/ 9/14/ 0/5/0	10.485	0.8065	0.7692	0.7353	0.6494	0.3937	0.1078	0.1134	0.1139	0.0000
354	6TH OF 6 SOLIDS	2/ 5/14/ 0/3/0	8.355	0.7246	0.6579	0.4237	0.2041	0.1543	0.0984	0.0000	0.0000	0.0000
364	1ST OF 6 SOLIDS	1/ 4/ 5/ 1/1/0	CLEAR	1.0204	1.0204	1.0638	1.0417	0.8475	0.8772	0.8065	0.7353	0.8621
364	2ND OF 6 SOLIDS	1/ 2/ 4/ 1/1/0	CLEAR	0.9804	0.9615	1.1111	0.9259	0.8772	0.7937	0.7143	0.7463	0.7353
364	3RD OF 6 SOLIDS	1/ 2/ 4/ 1/1/0	CLEAR	1.0000	1.0000	1.1364	0.8772	0.8475	0.7576	0.7463	0.7463	0.7692
364	4TH OF 6 SOLIDS	1/ 4/ 8/ 1/1/0	CLEAR	1.1111	1.0417	0.9804	0.7813	0.8065	0.8197	0.7353	0.6494	0.6757
364	5TH OF 6 SOLIDS	1/ 5/ 8/ 1/1/0	CLEAR	1.1111	1.0417	0.8772	0.8197	0.7813	0.7813	0.6329	0.6329	0.5814
364	6TH OF 6 SOLIDS	7/ 7/13/ 0/1/0	CLEAR	1.1111	1.0417	0.8333	0.8333	0.7692	0.7813	0.6610	0.6329	0.6098
368	1ST OF 6 SOLIDS	1/ 3/ 4/ 1/1/0	CLEAR	0.9434	0.8929	0.9091	0.8197	0.8333	0.8065	0.6250	0.5319	0.3759
368	2ND OF 6 SOLIDS	1/ 4/ 4/ 1/1/0	CLEAR	0.9804	0.8929	0.8772	0.8333	0.8475	0.7246	0.6667	0.5263	0.3846
368	3RD OF 6 SOLIDS	1/ 0/ 0/1/1/0	CLEAR	0.9259	0.9091	0.8621	0.8197	0.7692	0.7353	0.6494	0.5376	0.3906
368	4TH OF 6 SOLIDS	1/ 4/ 6/ 1/2/0	11.435	0.8621	0.8772	0.9615	0.8065	0.7463	0.7576	0.5263	0.4386	0.4098
368	5TH OF 6 SOLIDS	1/ 4/ 6/ 1/2/0	11.335	0.8772	0.8621	0.9259	0.8065	0.7463	0.7576	0.5155	0.4310	0.2994
368	6TH OF 6 SOLIDS	2/ 9/14/ 0/3/0	11.265	0.9091	0.8772	0.8475	0.7692	0.7813	0.6944	0.4902	0.4673	0.2762
427	1ST OF 6 SOLIDS	1/ 3/ 5/ 1/1/0	CLEAR	0.9804	0.8475	0.9259	0.8929	0.8197	0.9804	0.7246	0.7353	0.7692
427	2ND OF 6 SOLIDS	1/ 3/ 5/ 1/1/0	CLEAR	0.9434	0.9091	0.8929	0.9091	0.7813	0.9091	0.7042	0.7937	0.7463
427	3RD OF 6 SOLIDS	1/ 7/ 5/ 1/1/0	CLEAR	1.0000	0.9091	0.8929	0.8333	0.8475	0.9434	0.6849	0.7937	0.7246
427	4TH OF 6 SOLIDS	1/ 0/ 0/23/1/0	CLEAR	0.9434	0.9804	0.8929	0.9434	0.8197	0.9259	0.6944	0.7246	0.6410
427	5TH OF 6 SOLIDS	2/ 9/14/ 0/5/0	CLEAR	0.9259	0.7353	0.6944	0.6494	0.5376	0.4237	0.2315	0.1684	0.1845
427	6TH OF 6 SOLIDS	2/ 9/14/ 0/5/0	CLEAR	0.8929	0.7246	0.6667	0.6494	0.5051	0.3846	0.2016	0.1712	0.1953
453	1ST OF 6 SOLIDS	1/ 4/ 5/ 1/1/0	CLEAR	0.9259	0.9091	0.9259	0.8621	0.7463	0.8065	0.7353	0.7143	0.6944
453	2ND OF 6 SOLIDS	1/ 2/ 4/ 1/1/0	CLEAR	0.9434	0.9091	0.9091	0.7937	0.7813	0.7813	0.6757	0.6410	0.6173
453	3RD OF 6 SOLIDS	1/ 7/ 5/ 1/1/0	CLEAR	0.9434	0.8929	0.9091	0.7692	0.7813	0.7813	0.6494	0.6024	0.5618
453	4TH OF 6 SOLIDS	1/ 3/ 5/ 1/1/0	CLEAR	0.9615	1.0000	0.8772	0.7576	0.8065	0.7576	0.6410	0.5882	0.5155
453	5TH OF 6 SOLIDS	1/ 0/ 0/22/1/0	CLEAR	0.9091	0.9259	0.8929	0.8065	0.7937	0.7937	0.6173	0.6329	0.5747
453	6TH OF 6 SOLIDS	2/11/14/ 0/3/0	CLEAR	0.8772	0.8772	0.8772	0.8197	0.7937	0.7143	0.6173	0.5556	0.4762
487	1ST OF 6 SOLIDS	1/ 4/ 4/ 1/1/0	CLEAR	0.7276	1.1905	1.0204	1.0204	0.9434	0.9634	0.7353	0.7376	0.8065
487	2ND OF 6 SOLIDS	1/ 5/ 4/ 1/1/0	CLEAR	0.7813	1.0870	0.9804	1.0000	0.8772	0.8621	0.7663	0.7353	0.7576
487	3RD OF 6 SOLIDS	1/ 0/ 0/24/1/0	CLEAR	0.7692	1.0000	1.0000	0.9615	0.8929	0.8929	0.7692	0.6667	0.7463
487	4TH OF 6 SOLIDS	1/ 3/ 4/ 1/1/0	CLEAR	0.8475	0.8772	1.0000	0.9259	0.9615	0.8621	0.7062	0.6667	0.7042
487	5TH OF 6 SOLIDS	2/ 6/14/ 0/5/0	CLEAR	0.8475	0.7937	0.7576	0.6579	0.5435	0.4545	0.3012	0.2618	0.2941
487	6TH OF 6 SOLIDS	1/ 2/ 4/ 1/1/0	CLEAR	0.7042	0.7813	0.7692	0.6410	0.6098	0.5102	0.2976	0.2577	0.2976
233	1ST OF 7 SOLIDS	1/ 5/ 6/ 1/1/0	CLEAR	1.0204	0.8772	0.9259	0.9259	0.8772	0.8197	0.7692	0.7042	0.6849
233	2ND OF 7 SOLIDS	1/ 5/ 6/ 1/1/0	CLEAR	0.9615	0.8333	0.9259	0.8772	0.8197	0.8621	0.6849	0.6757	0.6667
233	3RD OF 7 SOLIDS	1/ 5/ 6/ 1/1/0	CLEAR	0.9804	0.9615	0.9259	0.9434	0.8772	0.8475	0.7143	0.6849	0.7143
233	4TH OF 7 SOLIDS	1/ 2/ 4/ 1/1/0	CLEAR	0.9804	0.9615	0.9091	1.0204	0.8065	0.8333	0.6579	0.6579	0.6173
233	5TH OF 7 SOLIDS	1/ 4/ 6/ 1/1/0	CLEAR	0.8772	0.9615	0.9259	0.8197	0.8065	0.9259	0.6098	0.6250	0.5556
233	6TH OF 7 SOLIDS	1/ 4/ 6/ 1/1/0	CLEAR	0.9434	0.8772	0.9259	0.8929	0.8197	0.8475	0.5882	0.6854	0.4545
233	7TH OF 7 SOLIDS	2/11/14/ 0/3/0	CLEAR	0.9434	0.8333	0.8621	0.7937	0.7353	0.6757	0.4545	0.3704	0.3546
249	1ST OF 7 SOLIDS	1/ 3/ 5/ 1/2/0	CLEAR	0.0000	0.0000	0.0000	0.0000	0.0000	0.0000	0.0000	0.0000	0.4673
249	2ND OF 7 SOLIDS	2/ 9/14/ 0/3/0	CLEAR	0.0000	0.0000	0.0000	0.0000	0.0000	0.0000	0.0000	0.0000	0.4762
249	3RD OF 7 SOLIDS	1/ 0/ 0/ 7/1/0	CLEAR	1.0204	1.1364	0.9615	0.7576	0.8475	0.8197	0.6494	0.3759	0.4386
249	4TH OF 7 SOLIDS	2/ 7/14/ 0/3/6	CLEAR	0.8772	0.8333	0.9615	0.8475	0.7062	0.7062	0.4625	0.2994	0.3448
249	5TH OF 7 SOLIDS	2/ 7/14/ 0/3/0	CLEAR	0.9434	0.8621	0.7692	0.7576	0.7062	0.5495	0.2793	0.3378	0.3846
249	6TH OF 7 SOLIDS	2/ 7/14/ 0/3/0	CLEAR	0.9434	0.7576	0.7692	0.7143	0.5952	0.4854	0.2926	0.3571	0.3817
249	7TH OF 7 SOLIDS	2/ 9/14/ 0/3/0	CLEAR	0.8197	0.7692	0.7576	0.6494	0.4310	0.3788	0.2762	0.2392	0.2546
261	1ST OF 7 SOLIDS	1/ 4/ 6/ 1/1/0	CLEAR	1.1364	1.0870	1.0870	0.8929	0.7813	0.8197	0.8621	0.6849	0.7937
261	2ND OF 7 SOLIDS	1/ 0/ 0/23/1/0	CLEAR	1.1364	1.0870	1.0638	0.8929	0.7813	0.8197	0.8333	0.6849	0.8065
261	3RD OF 7 SOLIDS	1/ 7/ 6/ 1/1/0	CLEAR	1.1111	0.9804	0.9615	0.8929	0.8621	0.7937	0.7576	0.7463	0.7246
261	4TH OF 7 SOLIDS	1/ 0/ 0/21/1/0	CLEAR	1.0638	0.8475	1.0417	0.9804	1.0204	0.7692	0.6494	0.7692	0.7813
261	5TH OF 7 SOLIDS	1/ 5/ 6/ 1/1/0	CLEAR	0.9434	0.9259	1.0204	1.0000	0.9259	0.8772	0.6024	0.6944	0.7042
261	6TH OF 7 SOLIDS	2/11/14/ 2/13/1	11.365	0.8065	0.8772	0.7692	0.7463	0.6410	0.5106	0.6024	0.6944	0.7042

261	6TH OF 7 SOLIDS	2/ 5/16/ 0/3/0	9.815	0.8533	0.7143	0.7042	0.5208	0.3185	0.2564	0.1196	0.0000	0.0000
331	1ST OF 7 SOLIDS	1/ 0/ 0/27/2/0	CLEAR	0.8475	0.8929	0.9615	0.7813	0.7937	0.7576	0.6494	0.6329	0.5635
331	2ND OF 7 SOLIDS	1/ 4/ 4/ 1/2/0	10.315	0.6757	0.8475	0.8197	0.7353	0.7353	0.6024	0.4310	0.1326	0.0000
331	3RD OF 7 SOLIDS	1/ 4/ 4/ 1/2/0	9.815	0.7463	0.7937	0.7143	0.7692	0.6250	0.5814	0.2674	0.0000	0.0000
331	4TH OF 7 SOLIDS	1/ 7/ 6/ 1/2/0	9.045	0.7692	0.7937	0.7463	0.7576	0.6024	0.5435	0.0000	0.0000	0.0000
331	5TH OF 7 SOLIDS	2/ 5/14/ 0/3/0	8.955	0.7437	0.8065	0.7937	0.7353	0.6024	0.5376	0.0000	0.0000	0.0000
331	6TH OF 7 SOLIDS	1/ 4/ 6/ 1/2/0	8.905	0.8065	0.8333	0.7937	0.7353	0.6250	0.4950	0.0000	0.0000	0.0000
331	7TH OF 7 SOLIDS	2/ 5/14/ 0/3/0	8.805	0.8772	0.8065	0.7576	0.6579	0.5814	0.4808	0.0000	0.0000	0.0000
406	1ST OF 7 SOLIDS	1/ 4/ 6/ 1/1/0	CLEAR	1.3158	0.8772	0.8475	0.9259	0.8475	0.6250	0.6667	0.7143	0.5952
406	2ND OF 7 SOLIDS	1/ 2/ 4/ 1/1/0	CLEAR	1.2500	0.8197	0.8475	0.9259	0.8929	0.6250	0.6667	0.7042	0.5814
406	3RD OF 7 SOLIDS	1/ 2/ 4/ 1/1/0	CLEAR	1.1111	0.8929	0.9259	0.8621	0.8065	0.7937	0.6694	0.7143	0.5747
406	4TH OF 7 SOLIDS	1/ 7/ 6/ 1/1/0	CLEAR	0.9259	1.0417	0.9259	0.7937	0.8475	0.7937	0.7042	0.6869	0.5263
406	5TH OF 7 SOLIDS	1/ 5/ 6/ 1/1/0	CLEAR	0.9259	1.0638	0.8621	0.8333	0.8333	0.8065	0.6024	0.5747	0.4808
406	6TH OF 7 SOLIDS	2/ 9/14/ 0/3/0	CLEAR	0.8475	0.8475	0.8475	0.8621	0.7692	0.6494	0.3876	0.4000	0.3704
406	7TH OF 7 SOLIDS	2/ 9/14/ 0/3/0	CLEAR	0.8533	0.7937	0.8475	0.7937	0.6944	0.5814	0.3968	0.4000	0.3704
485	1ST OF 7 SOLIDS	1/ 0/ 0/21/2/0	CLEAR	0.6849	0.7692	0.7143	0.8929	0.7143	0.9615	0.5319	0.4464	0.1412
485	2ND OF 7 SOLIDS	1/ 2/ 4/ 1/2/0	11.395	0.6444	0.7692	0.7576	0.8929	0.7353	0.9091	0.5376	0.4386	0.1253
485	3RD OF 7 SOLIDS	1/ 5/ 4/ 1/2/0	11.265	0.7042	0.7692	0.7463	0.9091	0.7463	0.8621	0.5376	0.4274	0.1131
485	4TH OF 7 SOLIDS	1/ 3/ 4/ 1/2/0	11.245	0.7042	0.8065	0.8065	0.8929	0.7042	0.8929	0.5263	0.4065	0.1059
485	5TH OF 7 SOLIDS	1/ 5/ 4/ 1/2/0	10.845	0.7437	0.8475	0.8475	0.8333	0.7937	0.8475	0.5051	0.4132	0.0000
485	6TH OF 7 SOLIDS	1/ 5/ 5/ 1/2/0	10.735	0.9091	0.8475	0.8475	0.8333	0.7813	0.6944	0.4587	0.2315	0.0000
485	7TH OF 7 SOLIDS	2/12/14/ 0/5/0	4.165	0.7576	0.0000	0.0000	0.0000	0.0000	0.0000	0.0000	0.0000	0.0000
109	1ST OF 8 SOLIDS	1/ 5/ 8/ 1/2/0	11.565	0.0000	0.0000	0.0000	0.0000	0.0000	0.0000	0.0000	0.0000	0.0000
109	2ND OF 8 SOLIDS	1/ 5/ 6/ 1/2/0	11.565	0.0000	0.0000	0.0000	0.0000	0.0000	0.0000	0.0000	0.0000	0.0000
109	3RD OF 8 SOLIDS	2/ 7/14/ 0/5/0	11.265	0.0000	0.0000	0.0000	0.0000	0.0000	0.0000	0.0000	0.0000	0.0000
109	4TH OF 8 SOLIDS	2/ 9/14/ 0/3/0	11.265	0.0000	0.0000	0.0000	0.0000	0.0000	0.0000	0.0000	0.0000	0.0000
109	5TH OF 8 SOLIDS	2/ 7/13/ 0/3/0	11.265	0.0000	0.0000	0.0000	0.0000	0.0000	0.0000	0.0000	0.0000	0.0000
109	6TH OF 8 SOLIDS	2/ 9/14/ 0/3/0	11.265	0.0000	0.0000	0.0000	0.0000	0.0000	0.0000	0.0000	0.0000	0.0000
109	7TH OF 8 SOLIDS	2/ 4/14/ 0/3/0	11.265	1.3514	1.0870	1.0870	0.8929	0.7353	0.6944	0.4505	0.0000	0.1366
109	8TH OF 8 SOLIDS	2/ 9/14/ 0/5/0	8.205	0.7143	0.7576	0.6579	0.5000	0.2193	0.0883	0.0000	0.0000	0.0000
131	1ST OF 8 SOLIDS	1/ 4/ 5/ 1/2/0	CLEAR	0.9015	1.0417	1.0204	0.8929	0.8197	0.7692	0.6667	0.6329	0.6579
131	2ND OF 8 SOLIDS	1/ 4/ 5/ 1/2/0	CLEAR	0.9434	1.0204	1.0000	0.8772	0.8929	0.7463	0.7042	0.6173	0.6579
131	3RD OF 8 SOLIDS	1/ 3/ 5/ 1/2/0	CLEAR	0.8929	1.1111	0.8929	0.9091	0.7576	0.8333	0.7266	0.6494	0.6250
131	4TH OF 8 SOLIDS	1/ 4/ 5/ 1/2/0	CLEAR	0.9404	0.9091	0.9434	0.8929	0.8475	0.7937	0.6757	0.6667	0.5263
131	5TH OF 8 SOLIDS	1/ 2/ 3/ 1/2/0	CLEAR	0.9015	0.8621	0.8929	0.8475	0.7692	0.7692	0.6757	0.5682	0.5376
131	6TH OF 8 SOLIDS	2/13/14/ 0/3/0	CLEAR	0.9434	0.8772	0.8929	0.8197	0.7353	0.7463	0.5495	0.2994	0.1359
131	7TH OF 8 SOLIDS	2/ 7/14/ 0/5/0	8.495	0.8065	0.7576	0.7937	0.5814	0.2717	0.2083	0.0000	0.0000	0.0000
131	8TH OF 8 SOLIDS	2/ 7/14/ 0/5/0	7.565	0.7463	0.7576	0.6173	0.3650	0.1799	0.0000	0.0000	0.0000	0.0000
133	1ST OF 8 SOLIDS	1/ 2/ 3/ 1/1/0	CLEAR	1.0638	1.0000	0.9091	0.8065	0.5051	0.7813	0.6410	0.5814	0.3472
133	2ND OF 8 SOLIDS	1/ 2/ 3/ 1/1/0	CLEAR	1.0417	0.9804	0.8772	0.6849	0.5319	0.7937	0.6757	0.5102	0.3846
133	3RD OF 8 SOLIDS	1/ 7/ 6/ 1/2/0	7.975	0.6098	0.7937	0.9259	0.7376	0.6173	0.0000	0.0000	0.0000	0.0000
133	4TH OF 8 SOLIDS	2/11/14/ 0/5/0	7.795	0.7692	0.8772	0.8197	0.7576	0.5263	0.0000	0.0000	0.0000	0.0000
133	5TH OF 8 SOLIDS	1/ 3/ 5/ 1/2/0	7.455	0.8621	0.7692	0.7143	0.5208	0.0238	0.0000	0.0000	0.0000	0.0000
133	6TH OF 8 SOLIDS	2/ 5/14/ 0/3/0	7.415	0.8197	0.7813	0.6944	0.4464	0.0210	0.0000	0.0000	0.0000	0.0000
133	7TH OF 8 SOLIDS	2/ 4/14/ 0/3/0	6.475	0.7437	0.7813	0.6329	0.2283	0.0000	0.0000	0.0000	0.0000	0.0000
133	8TH OF 8 SOLIDS	2/11/14/ 0/5/0	6.225	0.7813	0.7353	0.5556	0.1603	0.0000	0.0000	0.0000	0.0000	0.0000
176	1ST OF 8 SOLIDS	2/11/13/ 0/5/0	9.255	0.0000	0.0000	0.0000	0.0000	0.0000	0.0000	0.0000	0.0000	0.0000
176	2ND OF 8 SOLIDS	2/12/14/ 0/6/0	9.055	0.0000	0.0000	0.0000	0.0000	0.0000	0.0000	0.0000	0.0000	0.0000
176	3RD OF 8 SOLIDS	1/ 2/ 4/ 1/2/0	8.505	1.0870	0.8475	0.9091	0.8772	0.8333	0.8929	0.0000	0.0000	0.0000
176	4TH OF 8 SOLIDS	1/ 4/ 6/ 1/2/0	8.395	0.9091	0.8772	0.8929	0.9259	0.8772	0.8333	0.0000	0.0000	0.0000
176	5TH OF 8 SOLIDS	2/ 7/14/ 0/3/0	8.365	0.8197	0.8929	0.8929	0.7813	0.7937	0.6250	0.0000	0.0000	0.0000
176	6TH OF 8 SOLIDS	2/ 7/14/22/3/3	8.265	0.8929	0.8621	0.8621	0.8333	0.7813	0.0000	0.0000	0.0000	0.0000
176	7TH OF 8 SOLIDS	2/ 7/14/21/5/3	8.065	0.8533	0.8065	0.8333	0.7813	0.6173	0.0000	0.0000	0.0000	0.0000
176	8TH OF 8 SOLIDS	2/ 9/14/ 0/5/0	7.875	0.8772	0.8197	0.8333	0.7576	0.6098	0.0000	0.0000	0.0000	0.0000
202	1ST OF 8 SOLIDS	1/ 0/ 0/23/1/0	CLEAR	1.0638	1.0638	0.9804	1.0204	0.7937	0.8929	0.8065	0.7692	0.6757
202	2ND OF 8 SOLIDS	1/ 2/ 2/ 1/1/0	CLEAR	1.0638	1.0638	0.9804	1.0204	0.7937	0.8929	0.8065	0.7692	0.6757
202	3RD OF 8 SOLIDS	1/ 7/ 4/ 1/1/0	CLEAR	0.8929	0.9091	0.9091	0.8929	0.8333	0.8065	0.6494	0.5682	0.4065
202	4TH OF 8 SOLIDS	1/ 2/ 4/ 1/1/0	CLEAR	0.8929	0.9091	0.9091	0.8929	0.8333	0.8065	0.6494	0.5682	0.4065

202	5TH OF 8 SOLIDS	1/ 2/ 4/ 1/1/0	CLEAR	0.8929	0.9091	0.9091	0.8929	0.8333	0.8065	0.6494	0.5682	0.4065
202	6TH OF 8 SOLIDS	2/ 7/14/ 0/3/0	CLEAR	0.8333	0.7576	0.6379	0.4237	0.2825	0.2273	0.2000	0.2273	0.2273
202	7TH OF 8 SOLIDS	2/ 9/12/ 0/5/0	CLEAR	0.8197	0.6944	0.5747	0.3546	0.2778	0.2404	0.2083	0.2273	0.2273
202	8TH OF 8 SOLIDS	2/ 8/14/ 0/3/0	CLEAR	0.7576	0.6410	0.4098	0.2591	0.2033	0.2273	0.2083	0.2273	0.2273
239	1ST OF 8 SOLIDS	1/ 4/ 4/ 1/1/0	CLEAR	1.1628	1.1111	1.0417	0.9091	0.7813	0.8197	0.7246	0.7353	0.7576
239	2ND OF 8 SOLIDS	1/ 7/ 4/ 1/1/0	CLEAR	1.1905	1.0417	1.0204	0.8197	0.8065	0.8065	0.7246	0.7246	0.7463
239	3RD OF 8 SOLIDS	1/ 3/ 4/ 1/1/0	CLEAR	1.0638	0.9804	0.9091	0.8929	0.6329	0.8065	0.7246	0.6250	0.7353
239	4TH OF 8 SOLIDS	1/ 0/ 0/ 4/1/0	CLEAR	0.9091	0.8065	0.8475	1.0000	0.6849	0.6849	0.6173	0.4505	0.4464
239	5TH OF 8 SOLIDS	2/ 9/14/ 0/3/0	CLEAR	0.8333	0.8197	0.8772	0.7576	0.7813	0.7042	0.5618	0.4310	0.3676
239	6TH OF 8 SOLIDS	2/ 5/14/ 0/5/0	CLEAR	0.8929	0.7937	0.8772	0.7576	0.6494	0.4808	0.2994	0.3185	0.2890
239	7TH OF 8 SOLIDS	2/ 5/14/ 0/5/0	CLEAR	0.8621	0.7813	0.7353	0.6250	0.5102	0.3906	0.2924	0.3185	0.3378
239	8TH OF 8 SOLIDS	2/ 7/14/ 0/5/0	CLEAR	0.8772	0.7692	0.7042	0.5882	0.4902	0.3731	0.2924	0.3185	0.3333
346	1ST OF 8 SOLIDS	1/ 4/ 4/ 1/1/0	CLEAR	1.3889	1.1905	1.0000	0.9091	0.7463	0.6944	0.4950	0.8333	0.8475
346	2ND OF 8 SOLIDS	1/ 0/ 0/25/1/0	CLEAR	1.3158	1.1111	0.9091	0.8333	0.7143	0.5682	0.3731	0.6026	0.5102
346	3RD OF 8 SOLIDS	1/ 4/ 4/ 1/1/0	CLEAR	1.0000	0.9091	0.8475	0.7143	0.6098	0.4854	0.2604	0.3906	0.4545
346	4TH OF 8 SOLIDS	1/ 0/ 0/24/1/0	CLEAR	1.0417	0.9091	0.8197	0.7246	0.6098	0.4132	0.2203	0.3521	0.3546
346	5TH OF 8 SOLIDS	5/ 7/14/21/3/3	5.555	1.0417	0.7692	0.5435	0.0000	0.0000	0.0000	0.0000	0.0000	0.0000
346	6TH OF 8 SOLIDS	2/ 9/14/ 0/5/0	5.305	1.0417	0.7576	0.4505	0.0000	0.0000	0.0000	0.0000	0.0000	0.0000
346	7TH OF 8 SOLIDS	2/13/14/ 0/5/0	5.075	0.9615	0.7463	0.0000	0.0000	0.0000	0.0000	0.0000	0.0000	0.0000
346	8TH OF 8 SOLIDS	2/ 9/15/ 0/5/0	6.685	0.7937	0.5952	0.0000	0.0000	0.0000	0.0000	0.0000	0.0000	0.0000
433	1ST OF 8 SOLIDS	1/ 3/ 5/ 1/1/0	CLEAR	1.0417	1.2195	0.7576	0.9434	0.7353	0.6849	0.7576	0.6329	0.6849
433	2ND OF 8 SOLIDS	1/ 3/ 5/ 1/1/0	CLEAR	1.0417	1.0417	0.9091	0.9259	0.7246	0.6944	0.7463	0.6410	0.7042
433	3RD OF 8 SOLIDS	1/ 3/ 5/ 1/1/0	CLEAR	1.0404	1.0204	0.9615	0.9091	0.7143	0.7143	0.7353	0.6494	0.7042
433	4TH OF 8 SOLIDS	1/ 3/ 5/ 1/1/0	CLEAR	1.0000	1.0000	0.9259	0.8772	0.7246	0.7042	0.7246	0.6849	0.7042
433	5TH OF 8 SOLIDS	1/ 3/ 5/ 1/1/0	CLEAR	1.0000	1.0000	0.9091	0.8475	0.7576	0.7246	0.7042	0.6849	0.6944
433	6TH OF 8 SOLIDS	1/ 4/ 5/ 1/1/0	CLEAR	1.0000	1.0000	0.9091	0.8475	0.7813	0.7576	0.6944	0.6579	0.6579
433	7TH OF 8 SOLIDS	2/11/14/ 0/3/0	CLEAR	0.9804	0.8621	0.8333	0.8333	0.7463	0.7353	0.5952	0.5051	0.3821
433	8TH OF 8 SOLIDS	2/11/14/ 0/3/0	CLEAR	0.8621	0.8772	0.8929	0.7937	0.7576	0.7042	0.5682	0.4673	0.4167
463	1ST OF 8 SOLIDS	1/ 3/ 6/ 1/2/0	8.355	0.8621	0.8333	0.7576	0.7143	0.8333	0.2381	0.0000	0.0000	0.0000
463	2ND OF 8 SOLIDS	1/ 3/ 6/ 1/2/0	8.045	0.8621	0.8065	0.7143	0.8065	0.6410	0.0000	0.0000	0.0000	0.0000
463	3RD OF 8 SOLIDS	1/ 3/ 6/ 1/2/0	7.245	0.8621	0.7937	0.7143	0.6410	0.3697	0.0000	0.0000	0.0000	0.0000
463	4TH OF 8 SOLIDS	2/ 4/12/ 0/5/0	7.185	0.8621	0.8475	0.7042	0.6250	0.1225	0.0000	0.0000	0.0000	0.0000
463	5TH OF 8 SOLIDS	1/ 3/ 6/ 1/2/0	7.105	0.8772	0.8333	0.7246	0.5814	0.0000	0.0000	0.0000	0.0000	0.0000
463	6TH OF 8 SOLIDS	1/ 2/ 3/ 1/2/0	7.035	0.8621	0.8333	0.7937	0.5682	0.0000	0.0000	0.0000	0.0000	0.0000
463	7TH OF 8 SOLIDS	2/ 7/14/ 0/3/0	6.755	0.7553	0.8621	0.7246	0.5155	0.0000	0.0000	0.0000	0.0000	0.0000
463	8TH OF 8 SOLIDS	2/11/14/ 0/5/0	6.855	0.6944	0.6024	0.0000	0.0000	0.0000	0.0000	0.0000	0.0000	0.0000
134	1ST OF 9 SOLIDS	1/ 7/ 6/ 1/2/0	CLEAR	0.0000	0.0000	0.0000	0.0000	0.0000	0.0000	0.5952	0.5633	0.4368
134	2ND OF 9 SOLIDS	2/11/14/ 0/5/0	CLEAR	0.0000	0.0000	0.0000	0.0000	0.0000	0.0000	0.5952	0.5208	0.4167
134	3RD OF 9 SOLIDS	1/ 3/ 5/ 1/2/0	CLEAR	0.0000	0.0000	0.0000	0.0000	0.0000	0.0000	0.5747	0.4762	0.3968
134	4TH OF 9 SOLIDS	2/ 5/14/ 0/3/0	CLEAR	0.0000	0.0000	0.0000	0.0000	0.0000	0.0000	0.5747	0.4902	0.3968
134	5TH OF 9 SOLIDS	2/ 4/14/ 0/3/0	CLEAR	0.0000	0.0000	0.0000	0.0000	0.0000	0.0000	0.5814	0.4950	0.3968
134	6TH OF 9 SOLIDS	2/11/14/ 0/5/0	CLEAR	0.0000	0.0000	0.0000	0.0000	0.0000	0.0000	0.5814	0.5000	0.3937
134	7TH OF 9 SOLIDS	1/ 4/15/ 1/1/0	CLEAR	1.2195	1.4286	0.6849	0.7042	0.3906	0.6329	0.5319	0.4950	0.3906
134	8TH OF 9 SOLIDS	2/11/14/ 0/5/0	CLEAR	0.9434	1.3889	0.7813	0.5556	0.4545	0.5814	0.4348	0.4132	0.3226
134	9TH OF 9 SOLIDS	2/ 7/14/ 0/3/0	CLEAR	0.8475	0.8772	0.8197	0.6024	0.5682	0.5263	0.3106	0.2841	0.3546
300	1ST OF 9 SOLIDS	5/13/14/21/3/3	CLEAR	0.0000	0.0000	0.0000	0.0000	0.0000	0.0000	0.0000	0.0000	0.3597
300	2ND OF 9 SOLIDS	2/ 7/14/ 0/3/0	CLEAR	0.0000	0.0000	0.0000	0.0000	0.0000	0.0000	0.0000	0.3166	0.3268
300	3RD OF 9 SOLIDS	1/ 4/ 6/ 1/2/0	CLEAR	1.0000	0.9091	0.6849	0.9091	0.7813	0.8065	0.5618	0.3378	0.3106
300	4TH OF 9 SOLIDS	1/ 0/ 0/25/2/0	CLEAR	0.9091	0.8621	0.7813	0.8197	0.8197	0.7937	0.5102	0.3226	0.3448
300	5TH OF 9 SOLIDS	1/ 7/ 6/ 1/2/0	CLEAR	0.9091	0.8929	0.8333	0.8475	0.7813	0.8065	0.4630	0.3268	0.3185
300	6TH OF 9 SOLIDS	2/ 9/14/ 0/3/0	CLEAR	0.9091	0.9091	0.9091	0.8475	0.8065	0.7246	0.4587	0.3448	0.2924
300	7TH OF 9 SOLIDS	2/ 7/14/ 0/3/0	CLEAR	1.1628	1.0000	0.8197	0.7937	0.6329	0.5435	0.2525	0.0978	0.2994
300	8TH OF 9 SOLIDS	2/ 5/16/ 0/3/0	10.055	0.7813	0.6329	0.4902	0.2660	0.2415	0.2008	0.0000	0.0000	0.0000
300	9TH OF 9 SOLIDS	2/ 7/14/ 0/3/0	8.765	0.7576	0.5495	0.4545	0.2632	0.2262	0.1901	0.0000	0.0000	0.0000
464	1ST OF 9 SOLIDS	1/ 3/ 6/ 1/2/0	CLEAR	0.0000	0.0000	0.0000	0.0000	0.0000	0.0000	0.0000	0.3704	0.2841
464	2ND OF 9 SOLIDS	1/ 3/ 6/ 1/2/0	CLEAR	0.0000	0.0000	0.0000	0.0000	0.0000	0.0000	0.7376	0.3521	0.2874
464	3RD OF 9 SOLIDS	1/ 3/ 6/ 1/2/0	CLEAR	0.0000	0.0000	0.0000	0.0000	0.0000	0.0000	0.7246	0.3425	0.2841
464	4TH OF 9 SOLIDS	2/ 4/12/ 0/5/0	CLEAR	0.0000	0.0000	0.0000	0.0000	0.0000	0.0000	0.6944	0.3336	0.2825
464	5TH OF 9 SOLIDS	1/ 3/ 6/ 1/2/0	CLEAR	0.0000	0.0000	0.0000	0.0000	0.0000	0.0000	0.6579	0.3226	0.2809

