



Vivat Jesus et Maria!

From our Convent of The Good Shepherd.

Hammersmith, April 23rd, 1850

*"PRAY YE THE LORD, THAT HE MAY SEND LABOURERS
INTO HIS VINEYARD."*

In 1849, when the Good Shepherd Sisters headed a printed appeal for novices with the scriptural quotation shown above, they did not intend the irony of its application to the many lay-sisters and penitents who would be called upon to work in the magdalen asylum laundries.

In the Magdalen Movement the role of work as a process of individual mortification, and as a means of institutional self-support, reached its clearest expression with the establishment of John Eudes' order of Our Lady of Charity of the Refuge. That should not surprise us, as from the earliest times of christian monasticism work had been understood in that way. The documents examined in Chapter 1 revealed the degree to which the refuge nuns stood squarely in that tradition.

There we considered the theological rationale and the growing secular perception in the seventeenth century of a relation between moralism

and work. Some of the issues involved are taken up again in a subsequent chapter. The role of this chapter is to consider more closely the specific form of work adopted by the Good Shepherd Sisters for their magdalen asylums in Britain.

The account of the Hammersmith magdalen asylum showed how the laundry work rapidly became a major pre-occupation in the life of the institution, not infrequently distorting some of its traditional characteristics. Despite the early difficulties laundry work persisted, suggesting that there may have been a particular congruence between that form of work and the organisation and aims of the magdalen asylum. That this may have been so is further indicated by the failure of the nuns to establish efficient laundries at either the convict refuge or the certified inebriate reformatory without setting up a parallel class of penitents. To explore this question we need to examine in detail the nature of laundry work and the extent of its compatibility with both the internal organisation of the magdalen asylum and with the salient characteristics of the penitents as a group. In this way, we may be able to come to some clearer understanding of the material base of the Good Shepherd Sisters' engagement in the work of reformation and transformation. The specifically religious and symbolic significances of laundry work, and its possible congruence with the ideological aspects of the magdalen asylum, are discussed in Chapters 8 and 9.

Undoubtedly the initial decision to engage in laundry work was taken on primarily economic grounds. The shirtmaking and other plain needlework had produced only small and insufficient income. While it had the advantage of requiring very little outlay, the skills required (even elementary seam and hem stitching) were frequently beyond the capacity of the penitents. (1) Laundry work may well have been seen as holding out the possibility of a higher and more regular income from

a lower level of skill. The original idea had come from Mr. Robson and was received with considerable surprise. Needlework had been the normal productive work in Good Shepherd convents - a tradition deriving directly from the earliest Book of Customs - and the only laundry work undertaken was for the purposes of the house. Tradition apart, a new laundry business would require considerable capital outlay on building and equipment and much higher regular outgoings on fuel and laundry consumables such as soap, lye, blue, and starch. Such a venture would take the sisters into an order of capital totally beyond their means. The necessary funds were raised by subscription but were unfortunately embezzled by Mr. Robson, whereupon a loan was secured from the bishop to complete the building and equipping of
 (2)
 the laundry.

There is no direct evidence why Mr. Robson suggested laundry work but one can surmise that he was aware of the demand for washing in the rapidly developing middle class areas of West London. There was already a marked concentration of hand laundries in the region. These were primarily cottage enterprises conducted by the women and girls of poor families. They collected the soiled linen from middle
 (3)
 class households on Monday and returned it laundered on Saturdays. The nuns consulted other advisers and all were agreed that laundry work held the best potential as a secure basis for self-maintenance
 (4)
 by inmate employment. It was considered a realistic innovation motivated by economic necessity and involving a substantial but commercially acceptable risk. Not at this time, nor at any other time, do the convent books at Hammersmith or elsewhere record any explicit ideological rationale for the engagement in laundry work specifically. Nor is there any overt recognition of any deeper symbolic significance that laundry work might have held in the life of a Good Shepherd institution. The style of the Convent Annals and the Community

Letters is such that had ^{THE} symbolism of washing been immediately apparent to the sisters it would have been elaborated and recorded. From the want of such evidence it may be fairly concluded that the introduction of laundry work was simply a necessitous but discriminating response to available employment opportunities.

The Hammersmith laundry began work in April 1844 and by the end of 1847 it was operating with considerable success. Of the eleven new foundations made during the period ^{TO} 1911, all but one succeeded (5) in establishing a viable commercial laundry enterprise. Laundry work became the typical gainful employment of all the British Good Shepherd convents. When the first new foundations were made in 1851 at Glasgow and Bristol, it was natural that a respect for the Hammersmith convent, and a knowledge of its success, would have been a determining factor in the choice of work. There were, of course, other logics at work. By the middle of the nineteenth century the laundry trade generally was close to the take-off point for exponential growth, and the second half of the century was its heyday. (6) It was during precisely the same period that the main structure of Good Shepherd convents in Britain was established. A certain force must be conceded to the historical circumstances. In addition, the centres where laundry work was most in demand were those where prostitution flourished to its greatest extent. The main concentrations of laundry workers were to be found (7) in London and the large ports. The magdalen asylums established by the Good Shepherd sisters at London, Bristol, Glasgow, Liverpool and Newcastle were not short of custom once they had mastered the technicalities of the laundry process to a degree sufficient for customer satisfaction. There were vicissitudes, but they were overcome. This was not the case at other places. At Manchester where the foundation was made in 1867, the laundry was not securely established until the (8) early 1880's. The foundation at Glazenwood in Essex failed because

(9)
 insufficient laundry custom was available in a rural area. The laundry of the magdalen asylum at Ashford, which had succeeded the ill-fated C.I.R., managed to secure steady custom from the developing suburban belt in West Middlesex at the turn of the century, but operated at a loss. At Ashford the work with the penitents was supported by the large fee-income from the Ladies Inebriate Retreat which the sisters also conducted there.

(10)

The continuation of laundry work after the initial decision of 1843 must have been influenced by the external growth of the laundry trade. Yet, of itself, a burgeoning demand would have been insufficient to retain this type of work had it been inimical to the inner organisation and ideological content of the convents and magdalen asylums. The persistence of washing and laundering as the predominant work type in the Good Shepherd establishments can be further understood through a closer analysis of the laundry process itself. Laundry work is a sequential process which can be diagrammatically represented as follows:-

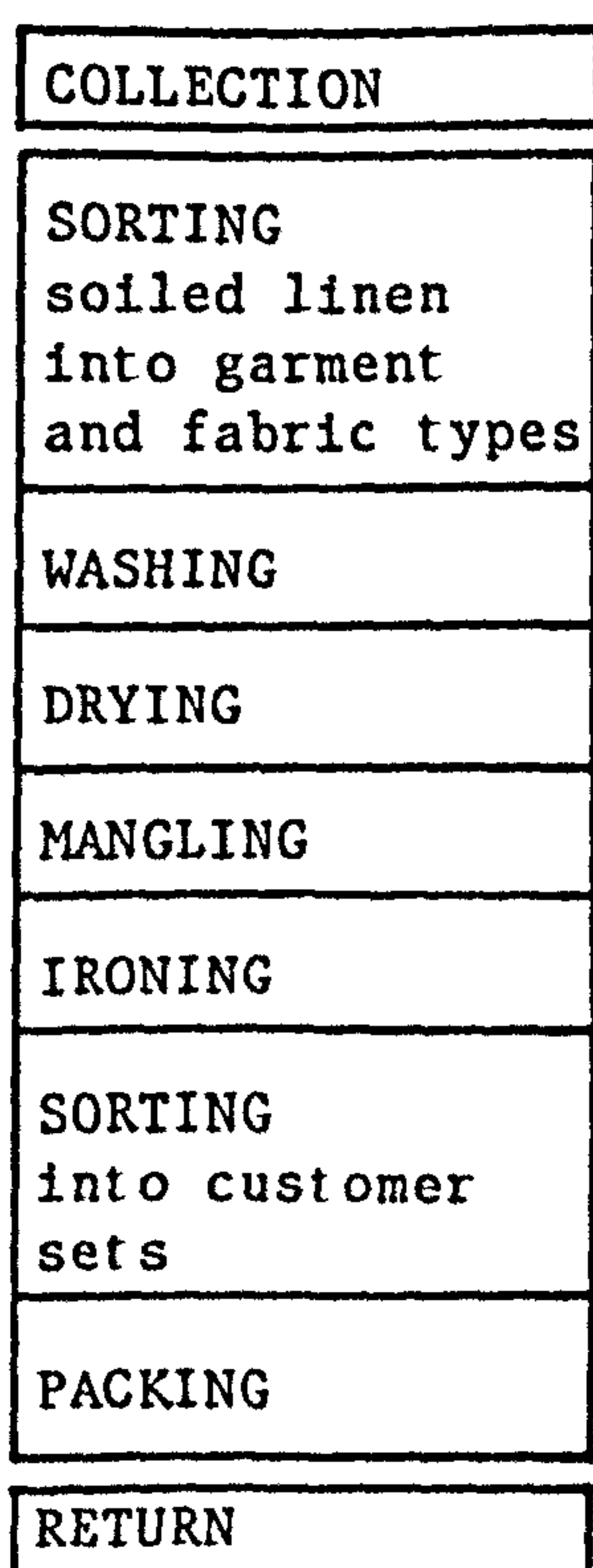
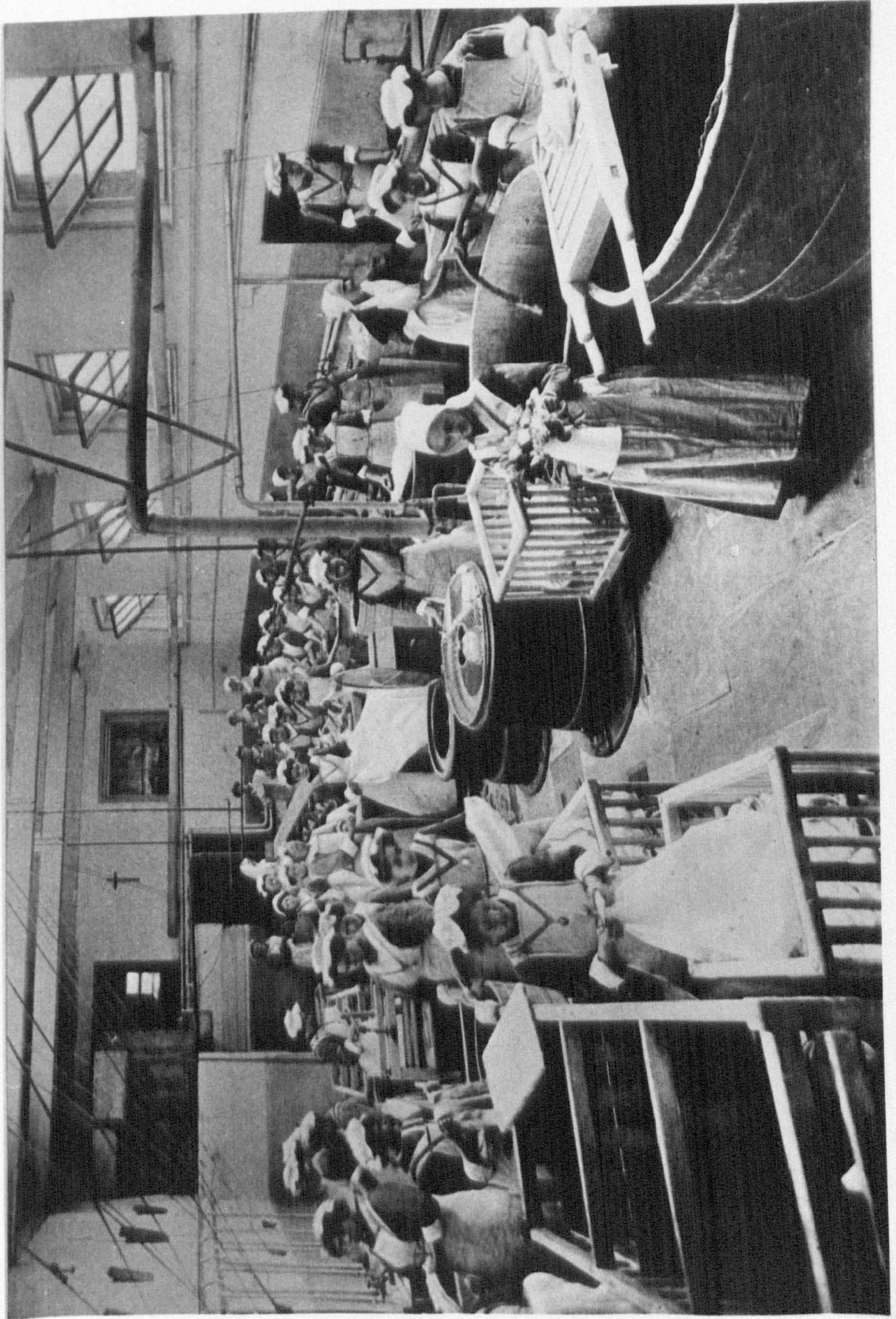

Figure 1: The Laundry Process

All the written accounts of laundry work in the convent books, the plans, and photographs reveal this basic pattern, whether they refer to the first laundry of 1844, the steam laundries of the 1870's, or the electrically powered laundries of 1912. The spatial arrangements may vary and overlap, but the operational sequence is invariable. The work is fully sequential.

On arrival the soiled linen is first marked with the customer name or code number and then sorted according to the type of garment or fabric, sheets or shirts, cotton or flannel, and so on. Marking and sorting a large pile of stale smelling soiled domestic and personal linen is a very unpleasant task, as the sisters were soon to discover. Within a few weeks of the commencement of the laundry the penitents refused to do this work as 'they did not like marking the dirty linen when it came in from the world'.⁽¹¹⁾ They were shamed into compliance after Mother Regaudiat and the nuns did the work themselves. In all the extant plans the same room was used for the initial sorting and marking as for the final sorting and packing. Given the sequential nature of the process, which ran on a weekly cycle largely determined by the domestic customers, this was an obvious economy in the use of space. However, it must have caused problems with contract work received later in the week, although sheets and table linen in bulk could have gone direct to the wash-room. In the case of a convent establishment such double usage was further determined by the value to the enclosure of restricting access to one point.

The first major department of the laundry was the wash-house or wash-room. Photographs 4 - 7 depict the wash-houses at Finchley and Liverpool between 1890 and the First World War. It was equipped along one end with a number of large coppers for boiling some kinds of items. In the early days these were heated directly by coal furnaces beneath, but within a few decades most were supplied with hot water reheated



Photograph 4: The Washroom at Finchley 1901

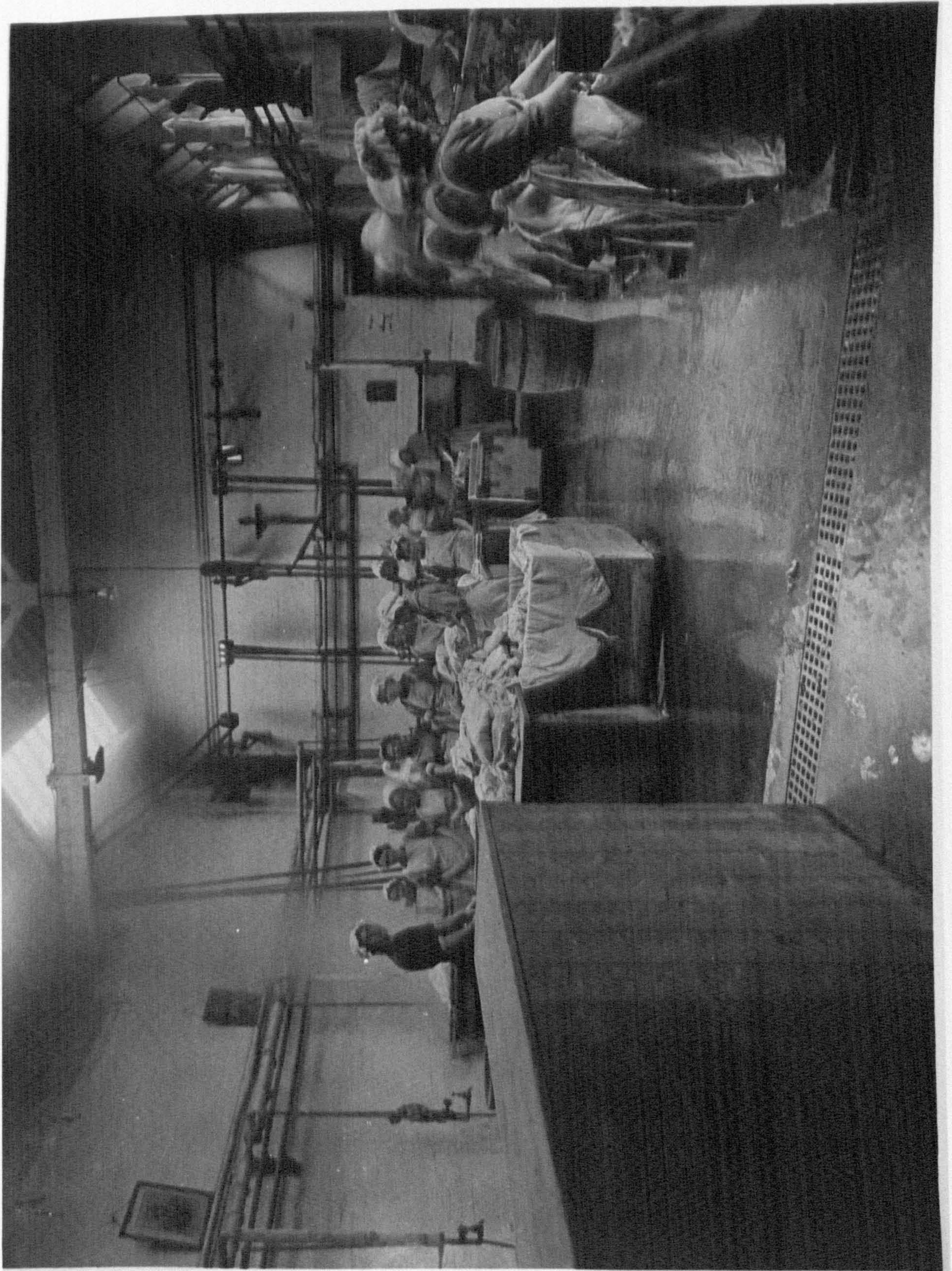

Photograph 5: The Washroom at Wavertree(Liverpool) 1902

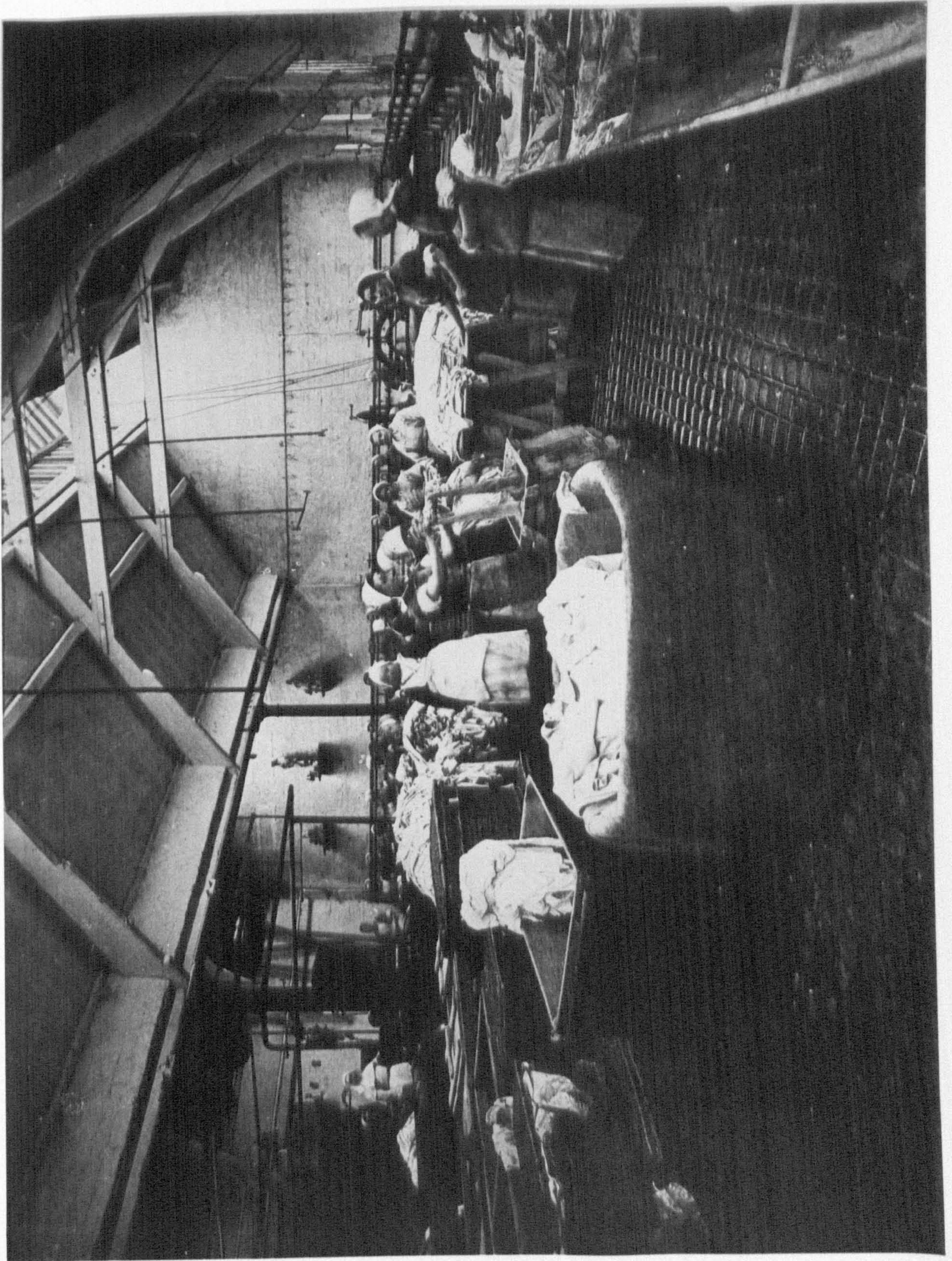

Photograph 6: The Washroom at Ford (Liverpool) c. 1895

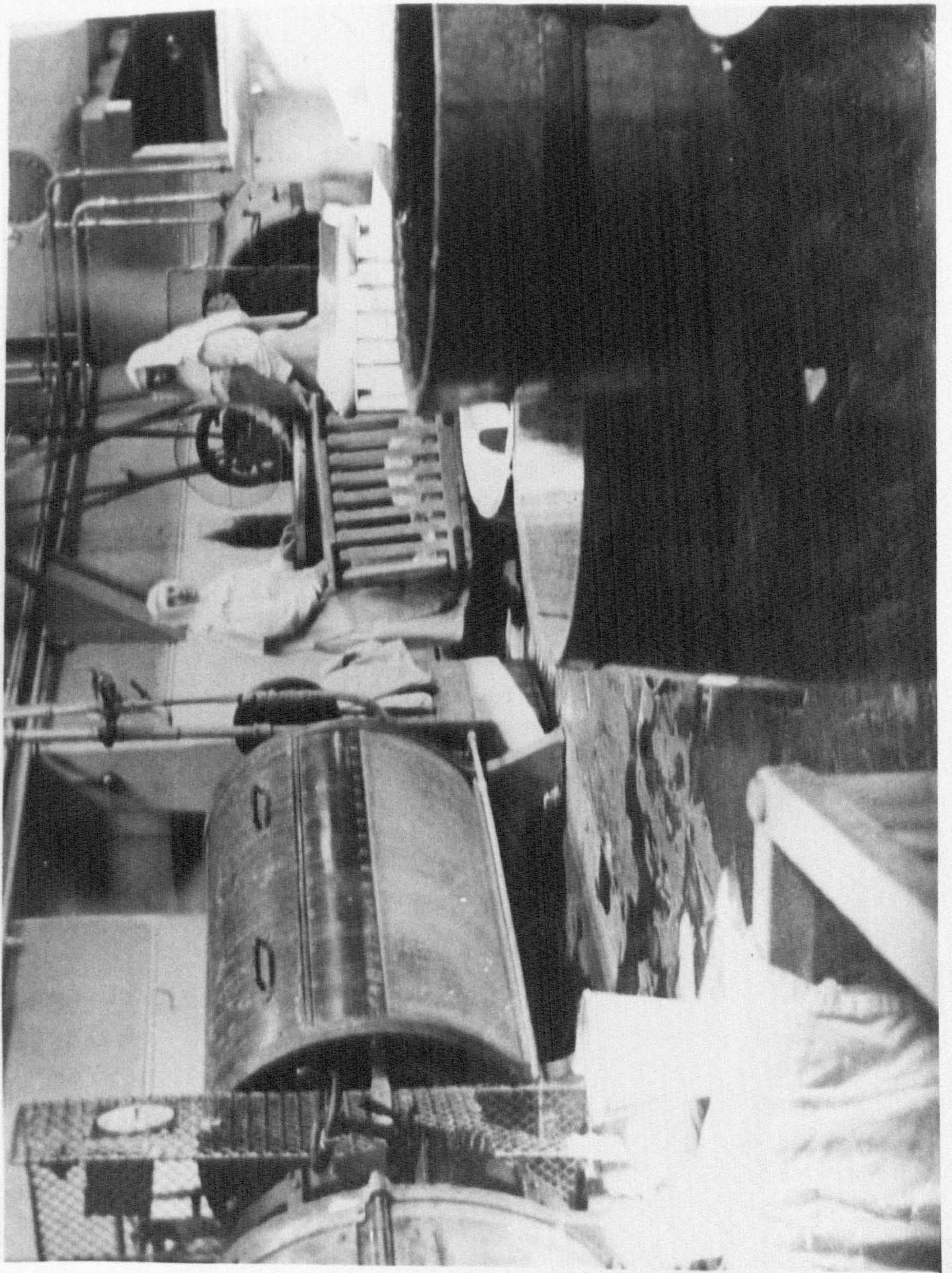

Photograph 7: The Washroom at Finchley c.1910

by steam piped from the same boiler system. In that case the boilers and furnaces were located in a separate room adjacent to the wash-room. Ranged round the walls were washing and rinsing troughs supplied with hot and cold water at which the penitents would work standing on wooden boards or gratings. At various places in the centre of the room stood the dolly tubs, water extractors, and squeezing troughs. Garments were first washed at the troughs by rubbing in soap and hot water on a washing board. This was followed by the pounding in the dolly tubs. They are clearly visible in photograph 4. They were made out of cut down brewers' or dyers' barrels and the pounding was done with a dolly stick or posser, of the type shown in the right of the illustration on the facing page. The clothes were then rinsed and boiled in the coppers for at least one hour. Finally they were rinsed again in three waters, warm, cool, and blue. When the washing was complete the clothes were placed in a centrifugal water extractor. This was of a cylindrical shape, standing vertically about waist high and fed from the top. At first they were hand operated but were available in steam driven form from the 1870's. Large items such as sheets were often put through a wringer instead. The used hot and cold water from all the wash-room processes drained off into an open gulley in
(12)
the centre of the floor.

Whatever the degree of mechanisation, and the Good Shepherd laundries were ahead of the secular laundries in this respect, work in the wash-room was hard and the conditions were exceedingly unhealthy. The pounding, rubbing, and lifting of sodden articles was backbreaking work in itself, a toil which was intensified by the damp and steam-laden atmosphere, poor ventilation, and wet floors:

'.... low roof, bad light, the impossibility of getting rid of the steam, made it unfit for the work and very injurious to the health of sisters and children, but

Dolly peg (right), washing punch and long-handled possor. Using a dolly peg is a strenuous task, requiring both a rotational and a vertical movement. The washing punch was used to similar effect but with less of a rotational action. Possers were used with a vigorous vertical movement and usually have a long handle with no cross-piece; small sink versions, sometimes with a crosspiece, were also available. Early possers were home-made of solid or perforated pine; mass-produced ones were made in a variety of patterns usually based on a perforated copper cone which worked at least partly by suction. A galvanised version called the Pearl Wash Pump incorporated a small bellows attachment.

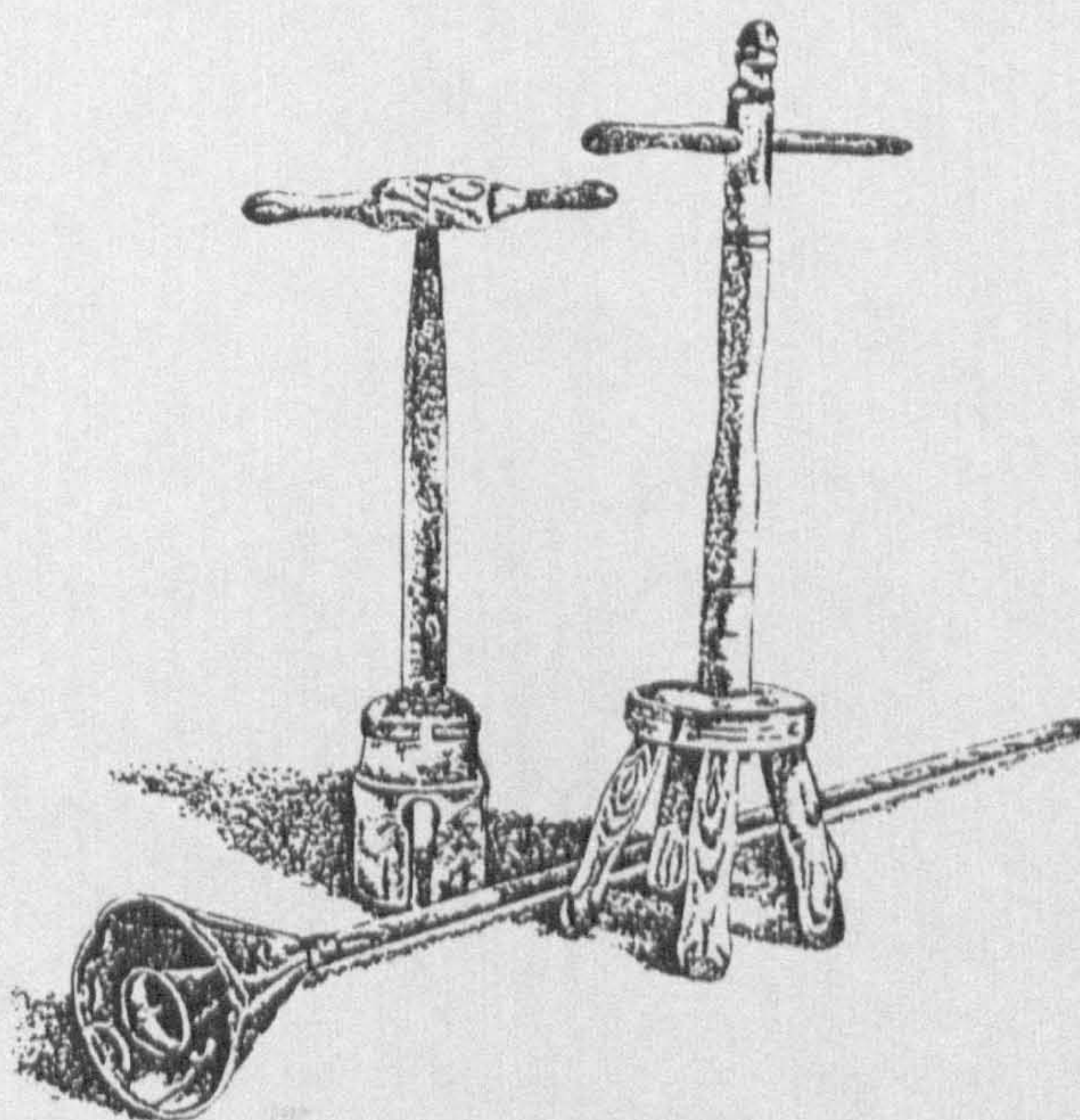

'how to improve it was a puzzle.'

(13)

That was at Bristol but similar tales were to be told at the other convents and not infrequently reference was made to illness and death attributed to such conditions. It was written of Sister Albert, one of the founding nuns and the first Good Shepherd sister to die in this country:

'She was a victim to the Laundry where she laboured in a way she had not been used to and the alterations of heat and cold brought on disease of the lungs.'

(14)

And that was within three years of the laundry opening. However good the drainage, substantial spillage was inevitable as wet items were transferred from one washing process to another. Higher ceilings and fan lights partially alleviated the conditions, but there was no really ameliorative change until stringent regulations for ventilation and drainage were imposed on the charitable laundries by the 1907 Factory Act. Even then an uncomfortable degree of dampness and humidity remained. The nature of the work ensured that the wash-room was always spatially discreet from the other laundry sequences.

A constant problem with the washing was that of securing a regular and sufficient supply of clean water. Although water companies had been established in the main conurbations by the 1840's, most of the Good Shepherd laundries were not connected to the supply until the late 1870's and 1880's. Given the serious and tiresome nature of the problem encountered it is surprising that the sisters did not sooner enter into contracts with the water companies, although high connection costs may have been partially responsible.

(15)

At Hammersmith a large brick cistern had been built beneath the wash-house to collect the rain water from the roofs of the buildings.

The dry weather problems have already been described; moreover, dependence on rain for washing contradicted the need of sun for drying and bleaching. Even if the elements had been propitious, there remained a more radical problem. The cess pool drained into the cistern and its contents:

'.... not infrequently turned from the right path and their bounden duty to molest the clear water, and distress and perplex the nuns.'

(16)

Several expensive attempts to remedy the problem failed and an artesian well was eventually sunk. Manchester experienced an identical problem. In their case, even when no 'inconvenience found its way into the water', the excessive amount of lime in the cement lining of the cistern (17) caused the water to damage the clothes. Most of the convents changed quickly from surface water collection to wells. Indeed, it was the introduction of steam pumps for these wells which precipitated the (18) introduction of steam power to the laundry generally. Several decades of carrying the huge amounts of water needed for the wash-room must have added considerably to the labours of the penitents.

The next three sequences of drying, mangling, and ironing, constituted the laundry work proper, although the word 'laundry' became used comprehensively to describe washing as well. The first laundry at Hammersmith was arranged in three separate rooms, the wash-room, laundry, and packing room. The drying and ironing were done in the laundry. The mangle was placed in the Class, but its noise proved very irritating to the needleworkers and within a year a separate (19) mangling room was added. During 1848 and 1849 this was extended and a drying room was provided. These early changes established the basic pattern for the spatial arrangement of the work sequences, a pattern adopted in all the subsequent laundries. The pattern is evident in Plans 1 - 5 of the laundries at Brook Green (1866), Cardiff (1875),

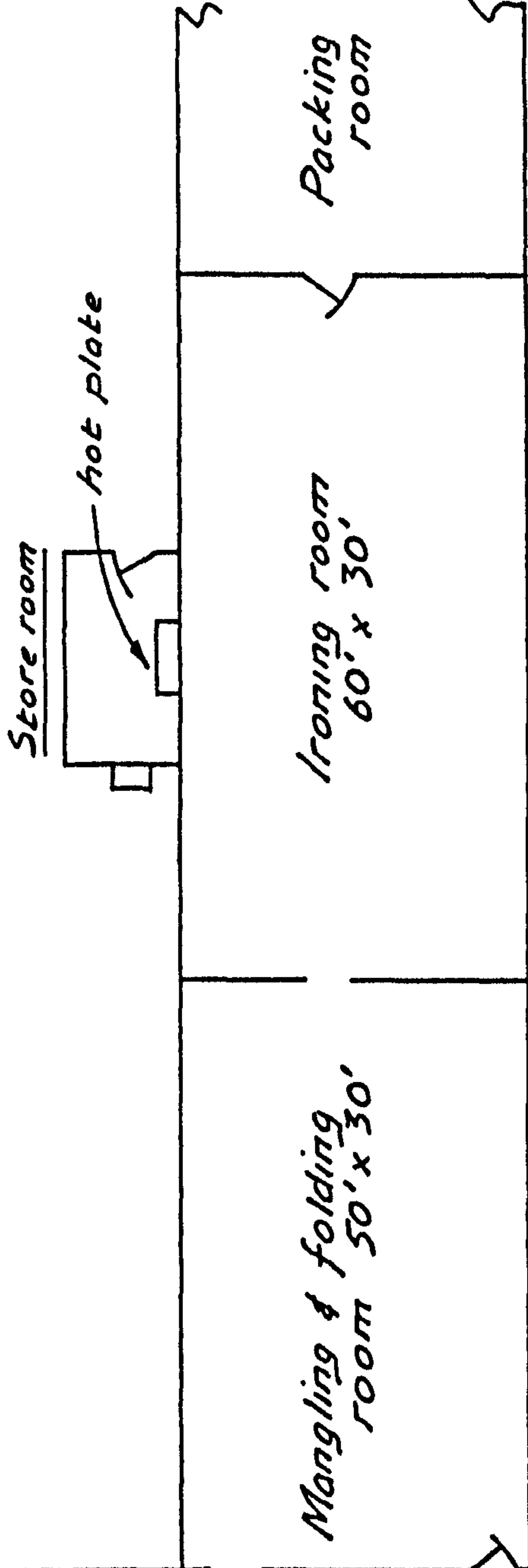
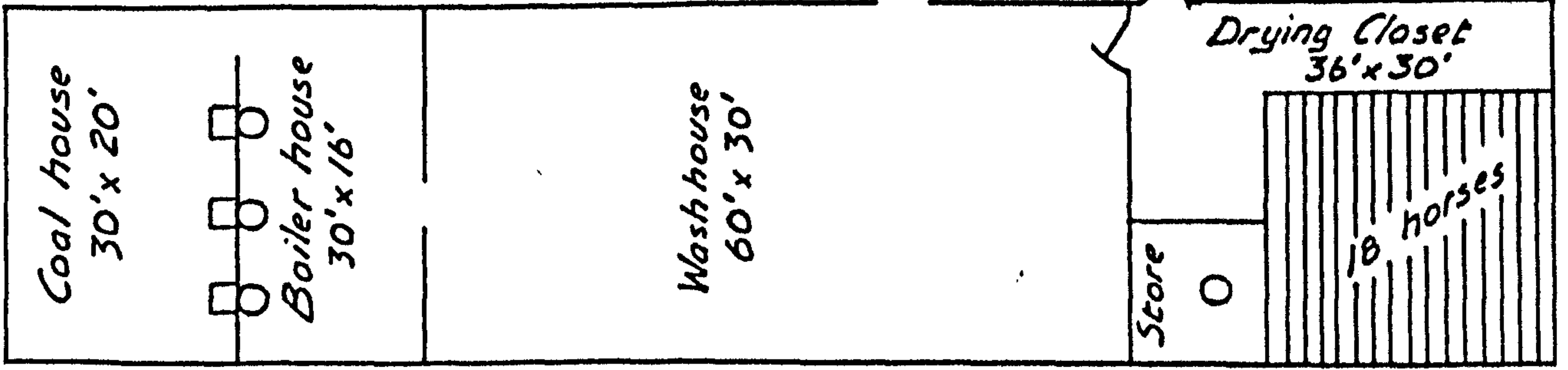

Scale: 1" = 20'

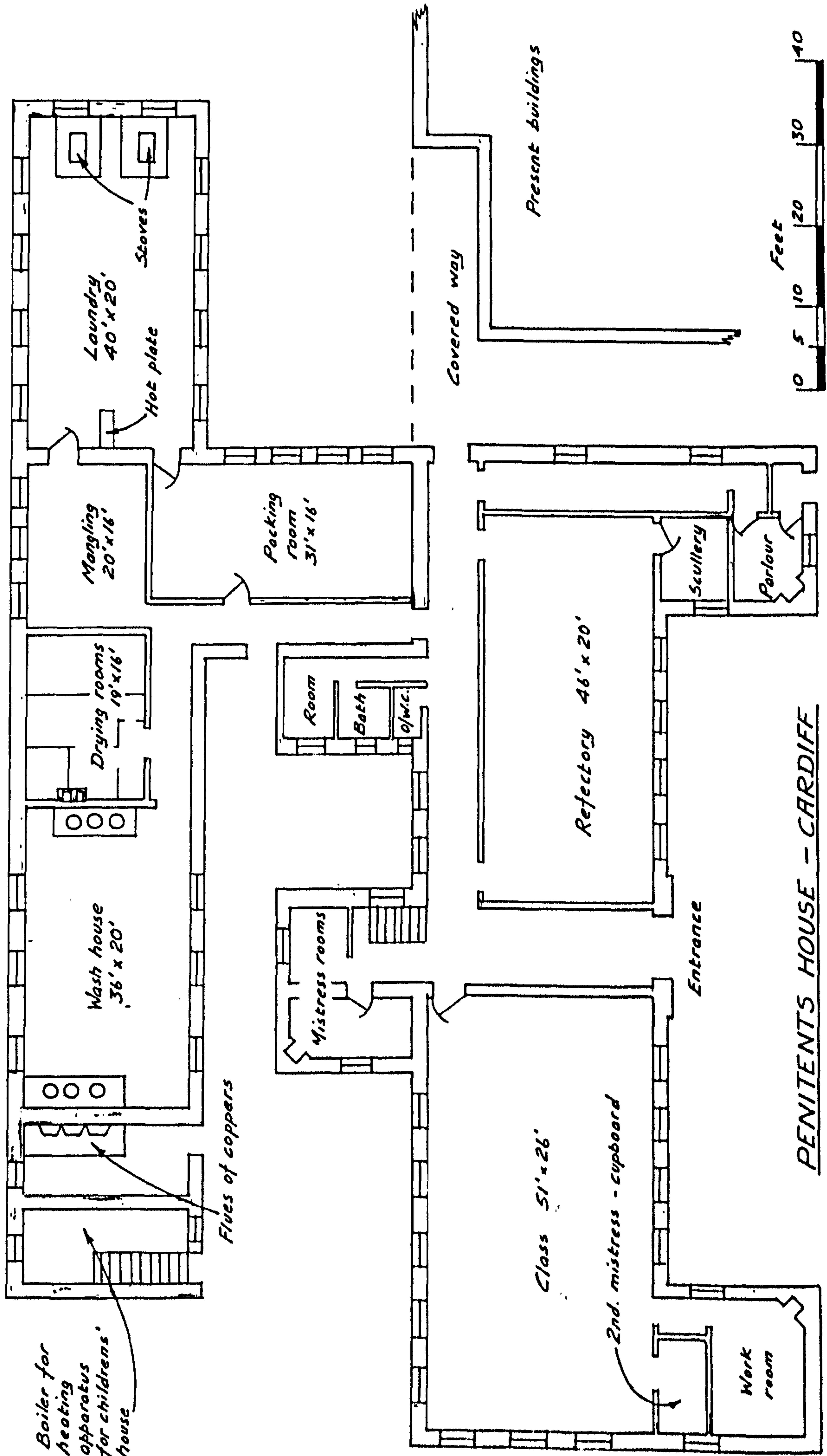

Approx. scale.

PENITENTS HOUSE - CARDIFF

Reproduced from the original dated 1875

CONVENT OF THE GOOD SHEPHERD - LIMERICK

PLAN OF STEAM LAUNDRY

Reproduction from the original dated - circa 1875

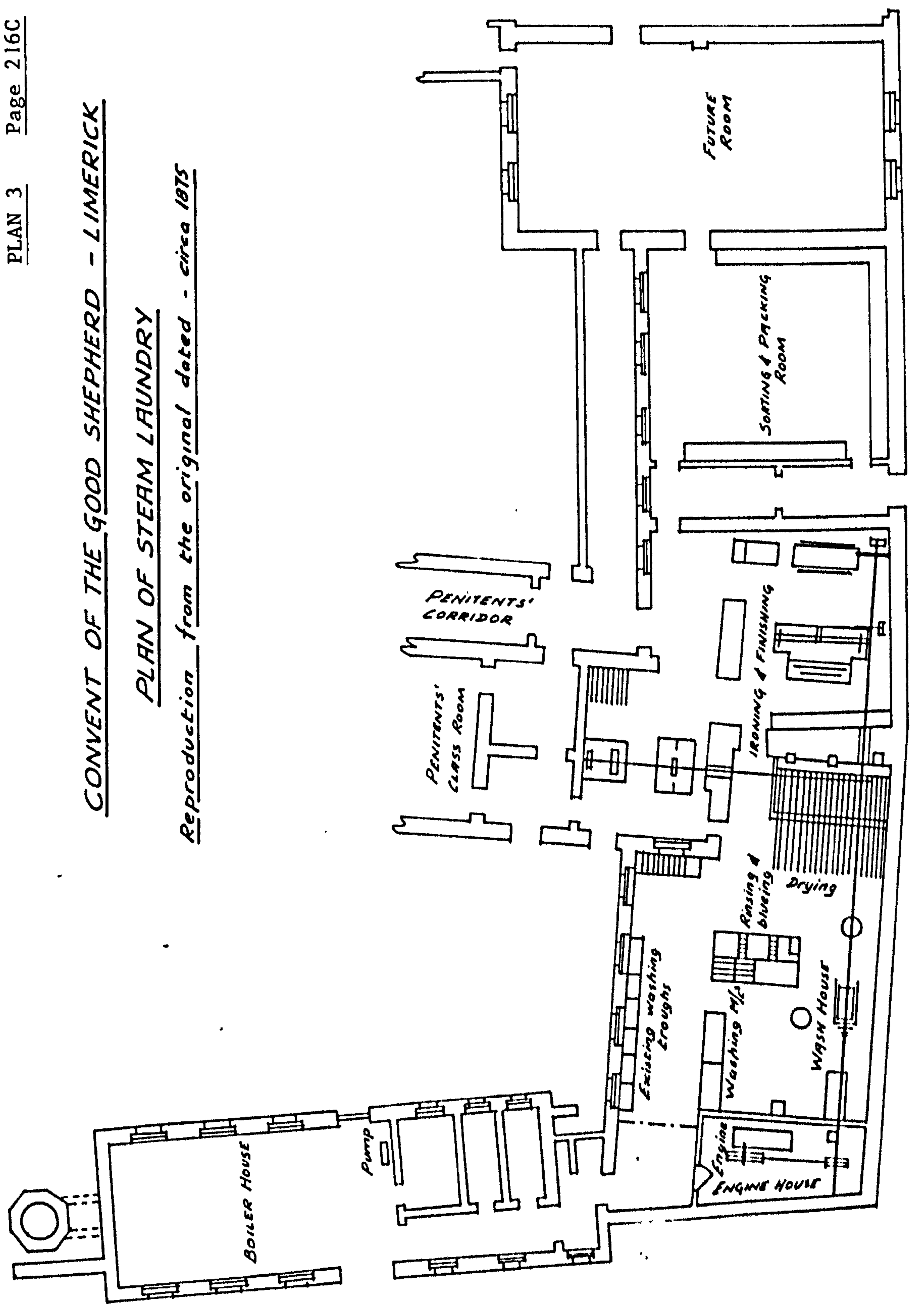

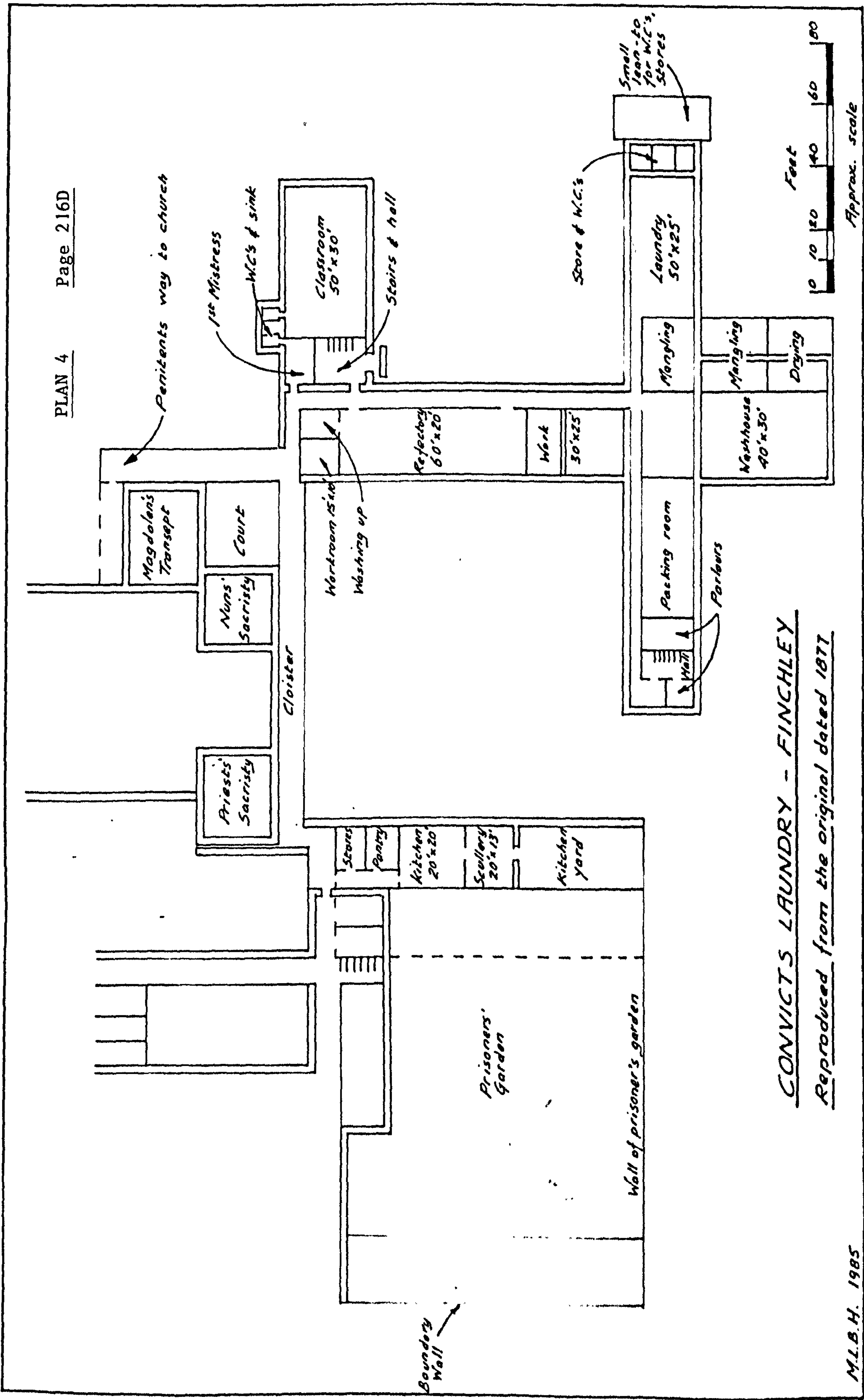

CONVICTS LAUNDRY - FINCHLEY
Reproduced from the original dated 1877

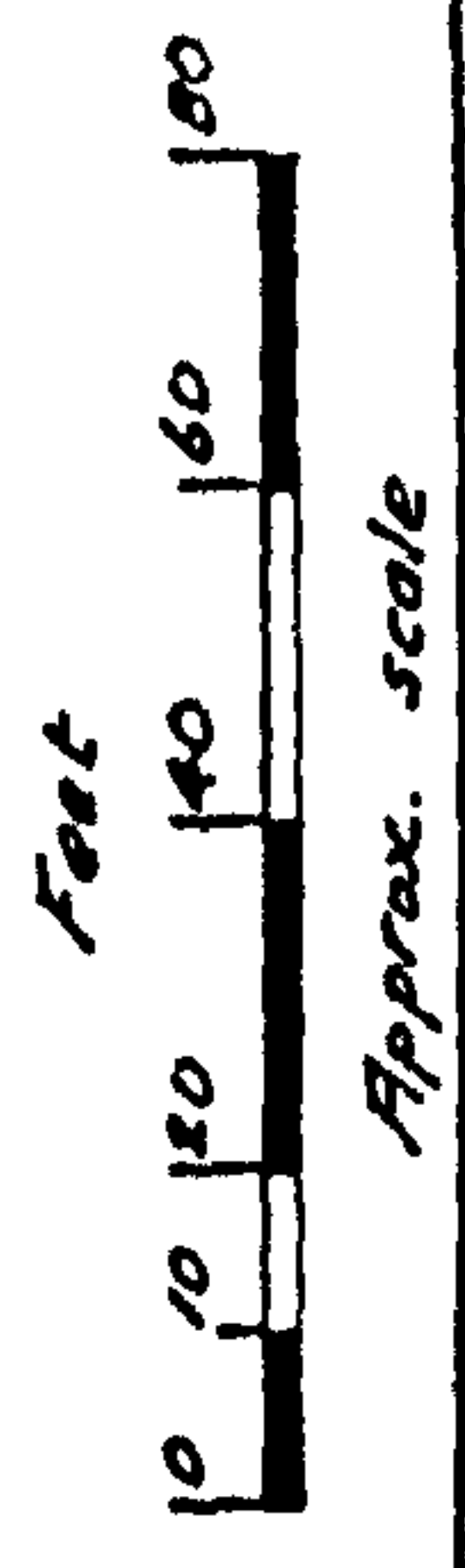

CONVENT OF GOOD SHEPHERD - DALBETH

Plan of additions to laundry

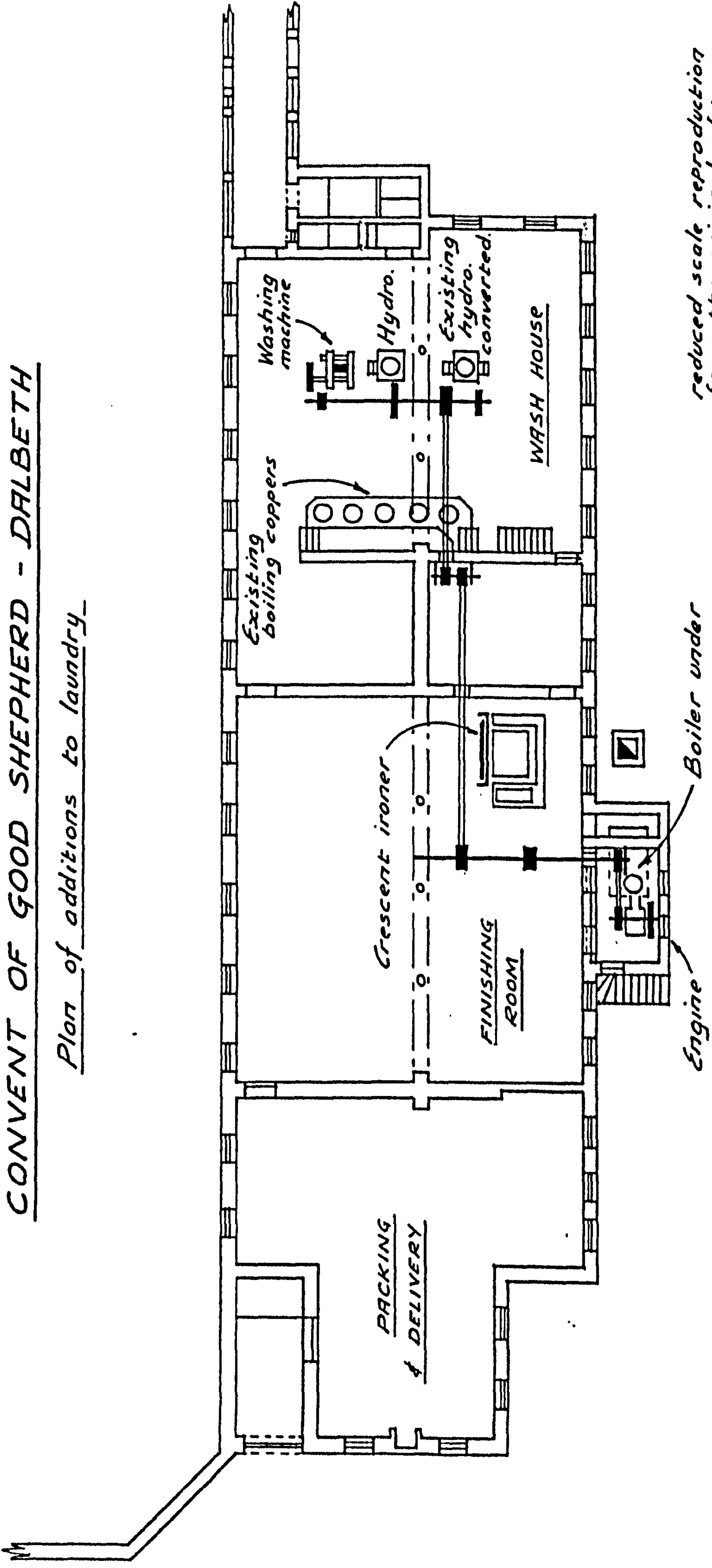

reduced scale reproduction
from the original of :-
15 July. 1897

by
THOMAS BRADFORD & Co
Engineers & Contractors.
Manufacturers of machinery
and apparatus for :-
laundries, baths, kitchens etc.
Manchester & London

Scale: 1 inch = 20 feet

Limerick (c.1875), Finchley (1877), and Glasgow (1897)

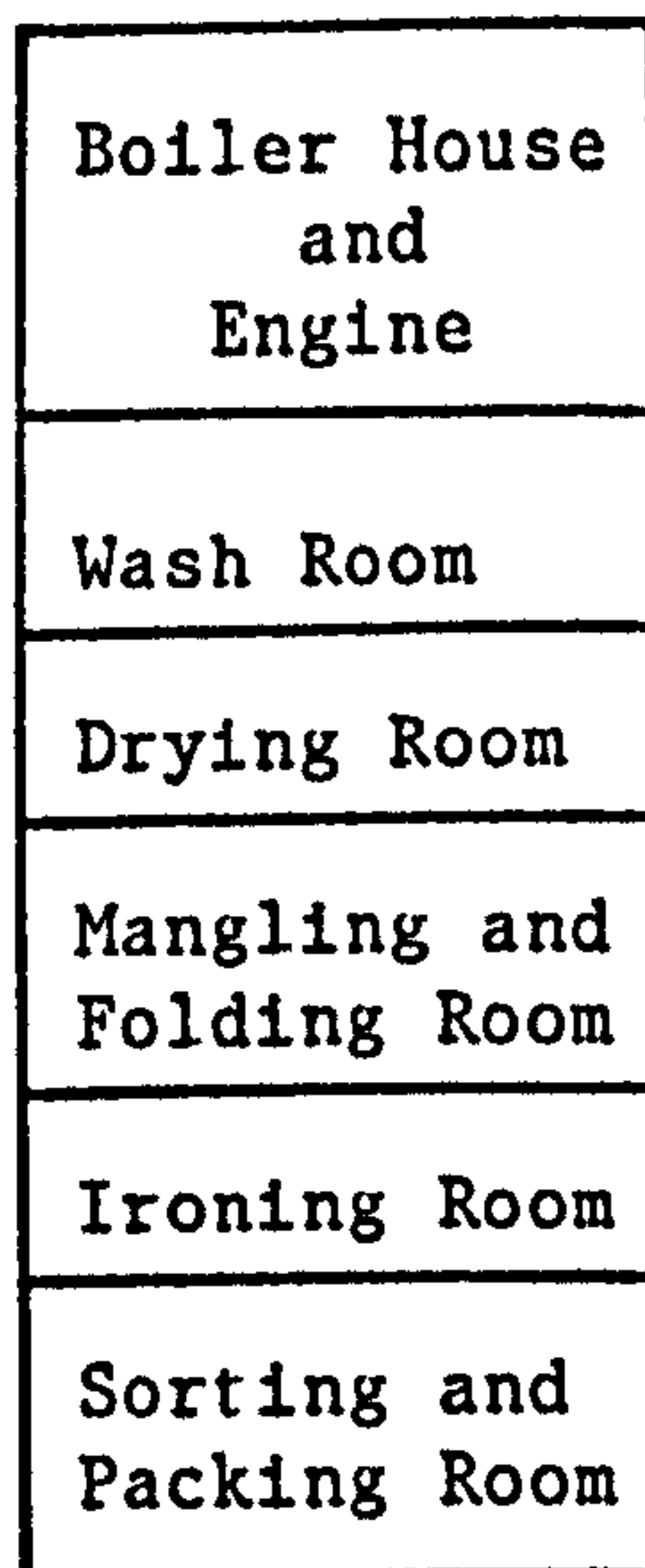
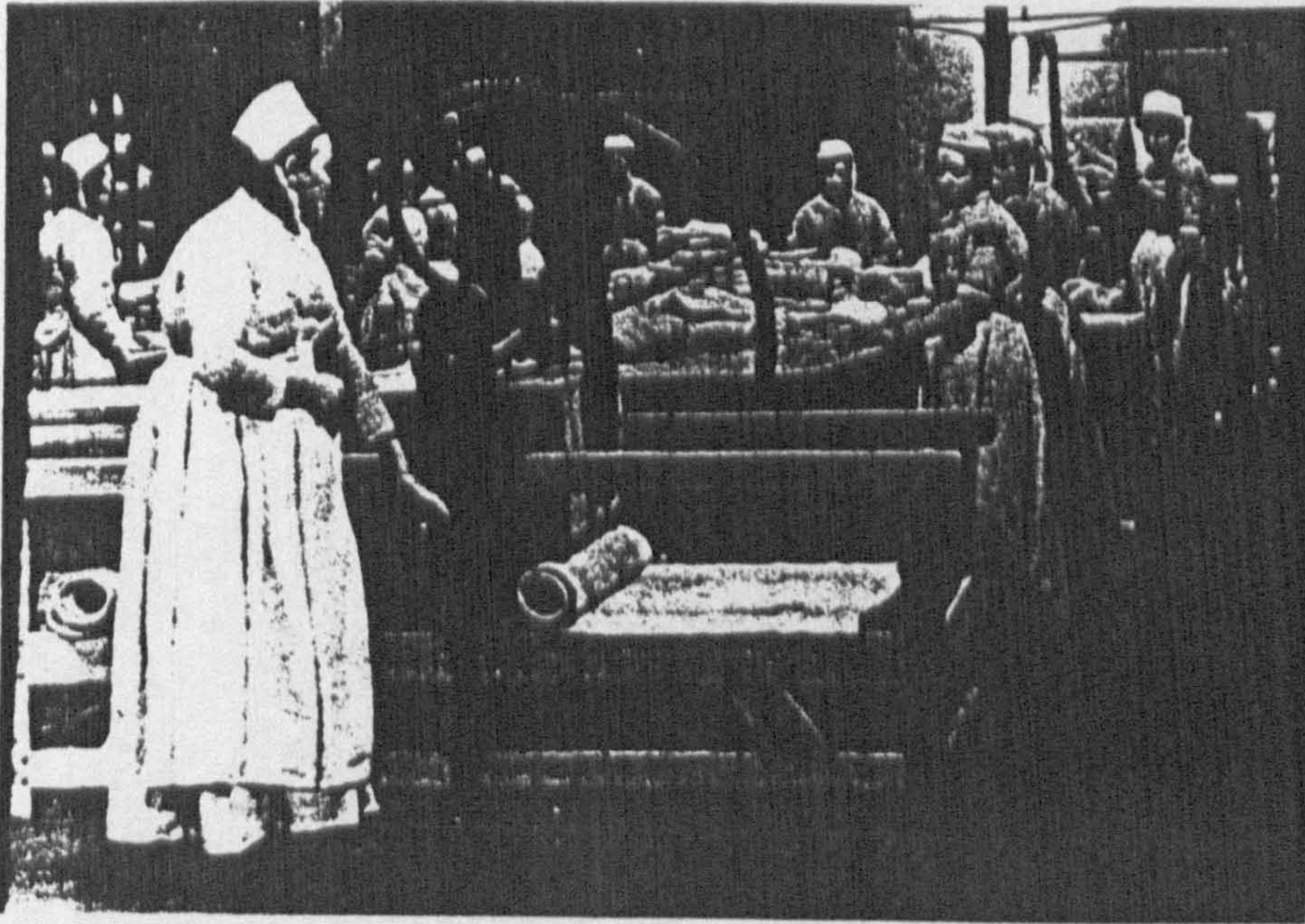

Figure 2: Spatial Arrangement of Work Sequences

Each laundry usually had a drying yard but this was only available in fine weather and was intended as much for the bleaching of white clothes as for drying. Most of the drying was done on large wooden drying racks mounted on runners that enabled them to be pushed in or out of the drying closet. The closet itself was normally heated by a contiguous hot air flue from its own furnace or that of the boiler. This was a dangerous system which often caused fires, some of them major. The danger of fire and the difficulty in obtaining adequate insurance cover led to problems at the Brook Green convict refuge, (20) and there were large fires at Bristol and Glasgow. The dry direct heat also had a baking effect on the clothes. Despite the drawbacks and dangers of this system, no significant improvements in drying closet design were made until the turn of the century when a method of blowing air over steam pipes and through the clothes was introduced.

In addition to the drying closet, clothes were often hung on free-standing clothes horses placed around the ironing stove or on lengths of wood which were hoisted to the ceiling by rope and pulley. On days when the drying apparatus failed, or the weather prevented the use of the drying yard, or even when the volume of work was too

The dry laundry at Wormwood Scrubs Prison in the 1890s, showing a box mangle. The laundry dealt with the clothing for 1,400 prisoners.



great, the overhead drying caused very unpleasant humidity in the laundry. This practice was very much criticised during the many enquiries, both public and private, that surrounded the attempt to bring laundries under the factory acts in 1895 and 1907. It was not specifically legislated against due to the difficulty of enforcement. It was rather difficult to draw a precise line between damp clothes drying or ironed clothes airing while awaiting the specialist attention of a collar ironer or a folder ironer. The practise is shown in Photograph 8 which was taken in the mid-1920's at Snaresbrook, the successor house to Hammersmith.

Some large items, particularly sheets and table cloths, bypassed the hot drying sequence and went direct to the mangle. Mangling smooths and polishes dry or damp articles by passing them around a wooden roller. Large items frequently required no ironing afterwards especially if folded carefully. Turning the mangle was hard work. In the cottage laundries it was often left to the man of the family, while in the larger commercial hand laundries men were frequently employed for this purpose. (21) The mangles came in various sizes but were of two basic types. The box mangle consisted of a weighted box on a platform mounted in a frame. The clothes were folded around wooden rollers. Two of these were then placed between the platform and the box, which was moved to and fro by a hand-turned gearing system. The other type stood upright and consisted of two geared rollers through which the clothes were passed by one person while the other turned the handle. There was a device for adjusting the pressure between the rollers. The secret of successful mangling lay in careful folding, a steady unbroken turning action and the choice of a correct pressure. The various types of mangles and irons are illustrated on the inserted pages.



Photograph 8: The Ironing Room at Snaresbrook c.1924

WASHING, WRINGING, AND MANGLING MACHINES.

Apparatus to order only and sent direct from the manufacturers, carriage paid to any Railway Station in England, except those marked.

Bradford's Yowel A Washing Machine.
To order only

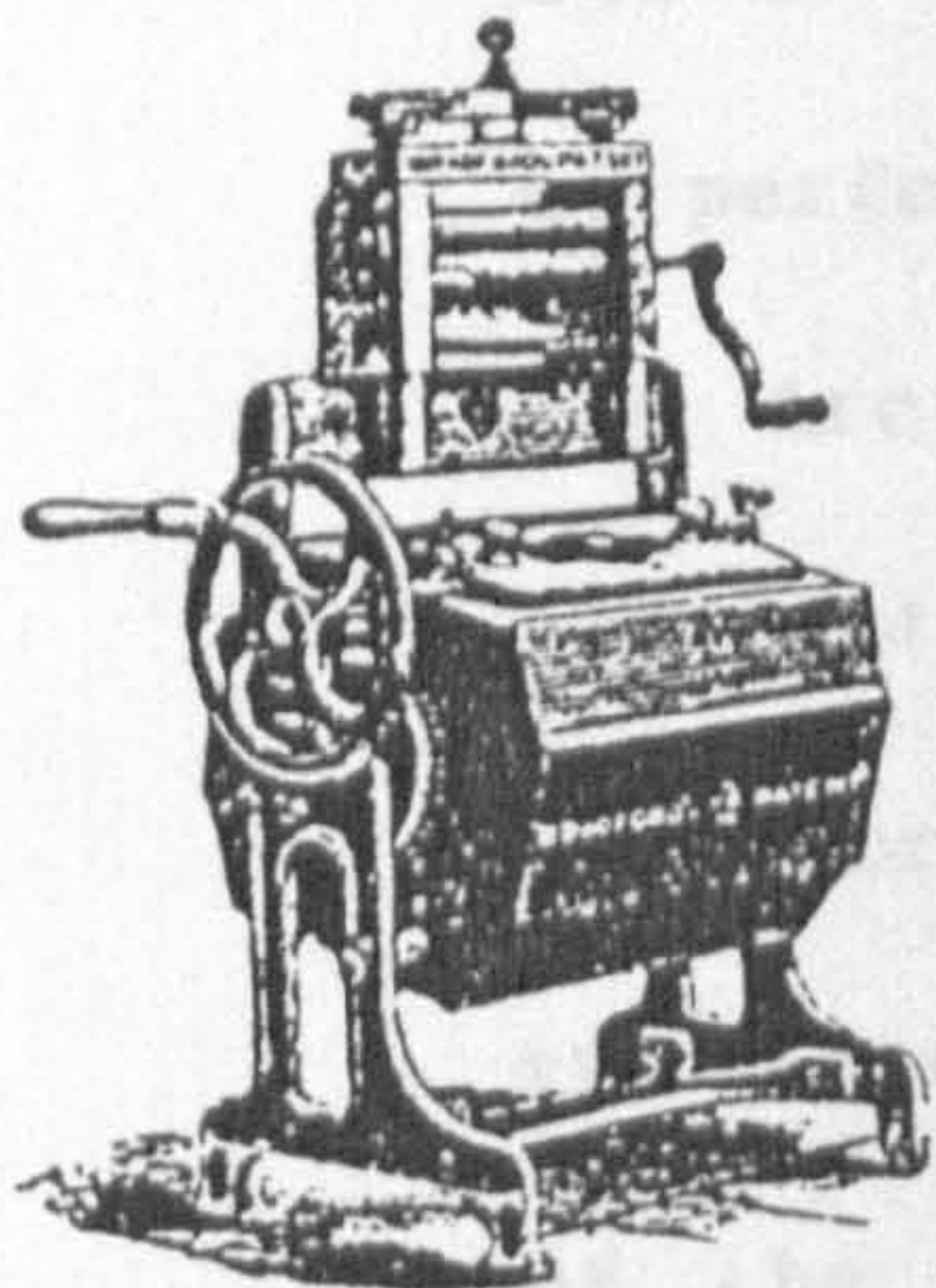

The Safety. To order only

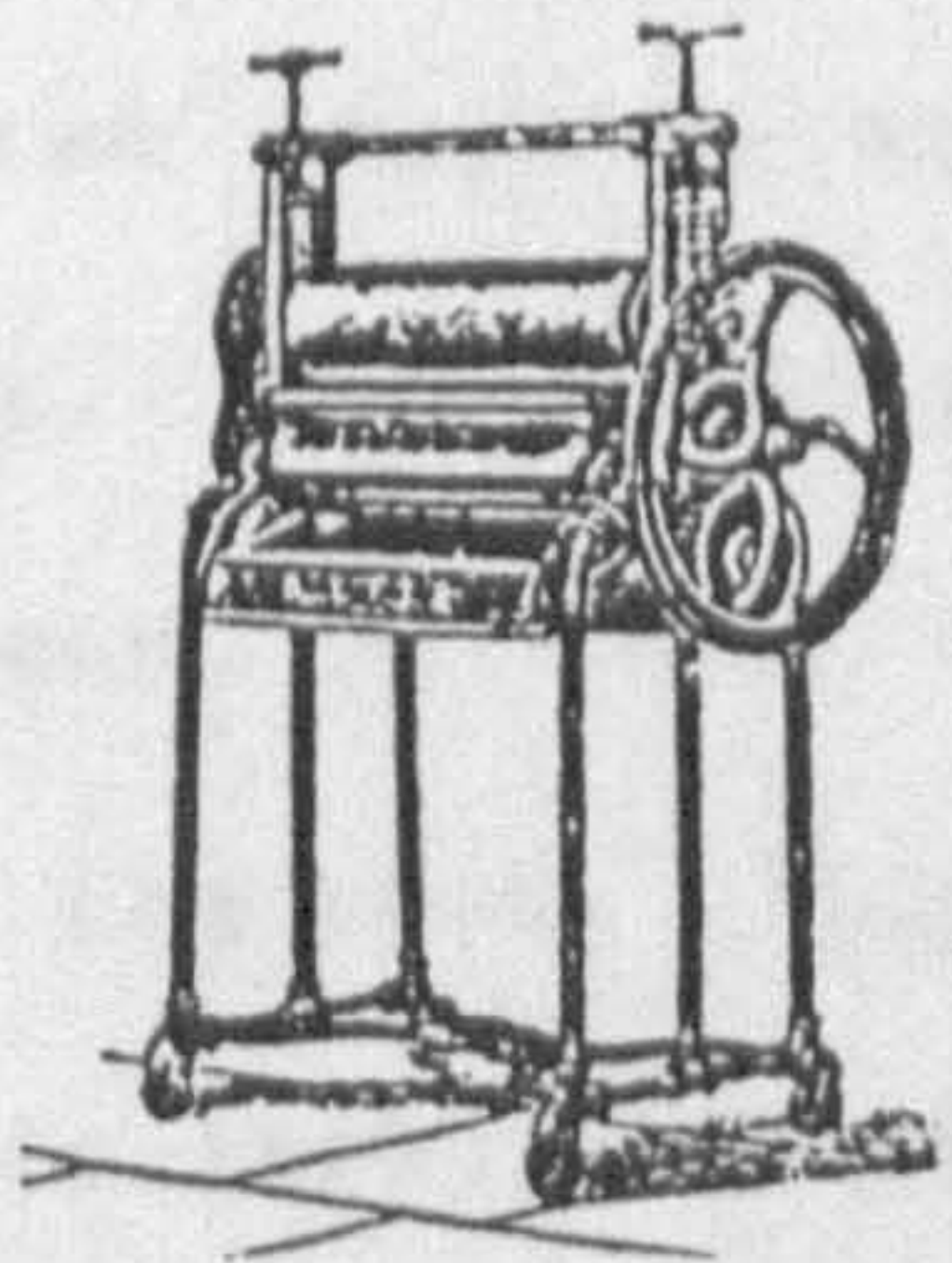

No 130. Brass capped rollers.
21 in. 47/0 24 in. 49/0 27 in. 52/6 30 in. 56/0

Bradford's Ye Tudor.
To order only.

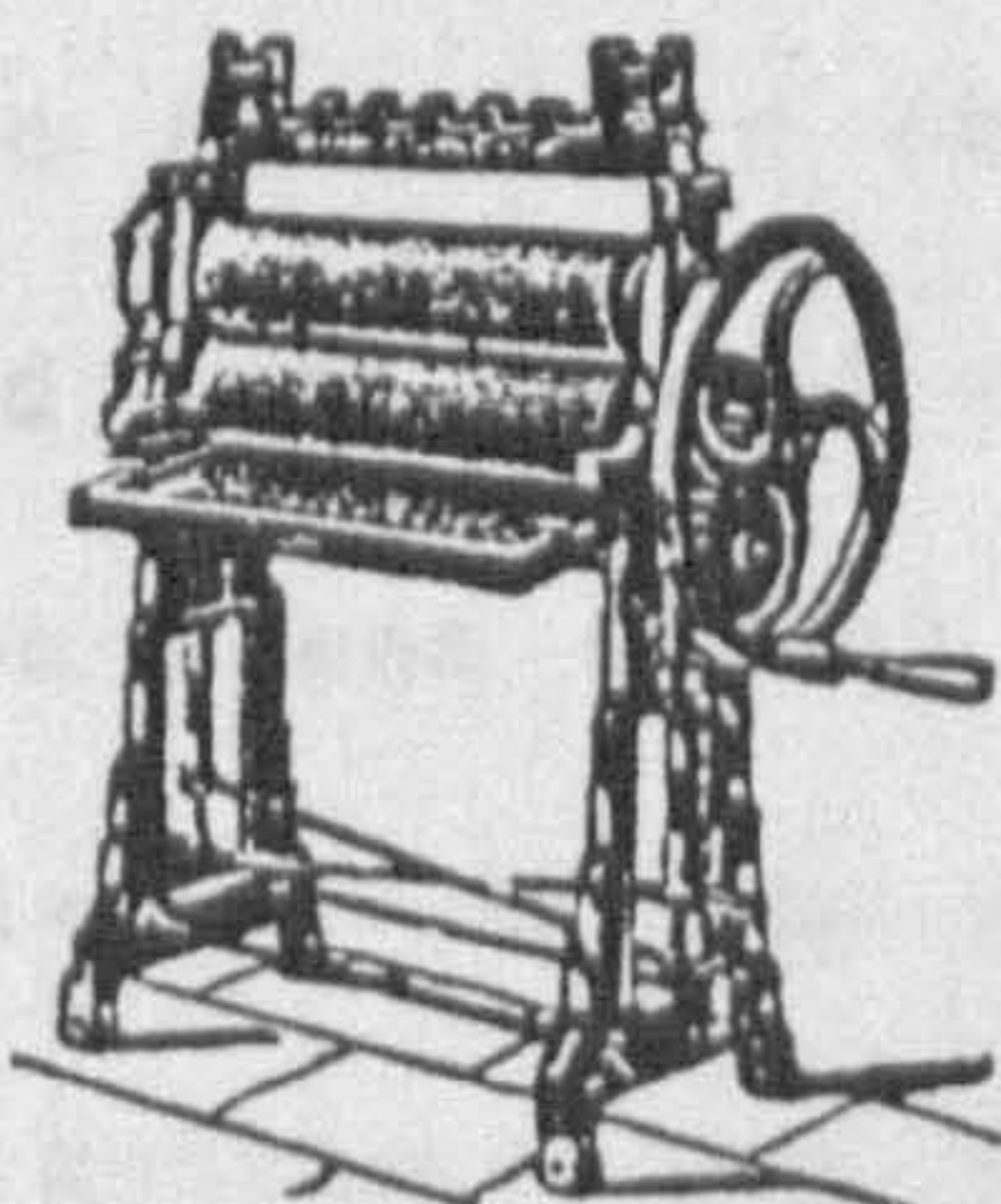

W. 24 in rollers each 61/8
X. 24 " " brass capped .. 63/9
Y. 27 " " " " " " " " 68/0
Z. 30 " " " " " " " " 76/6

Patent Box Mangles.

Size	Price	Room to work each size.
5 ft 0 in.	155/3	8 ft. 3 in.
5 " 6 "	165/6	9 " 4 "
6 " 0 "	186/3	10 " 4 "
6 " 6 "	207/0	11 " 4 "
7 " 0 "	259/0	12 " 4 "

*The above sent direct from manufacturers, carriage not paid to country. The prices include delivering, fixing, and loading in London, or packing and putting on rails for country.

Convertible Table Mangle.

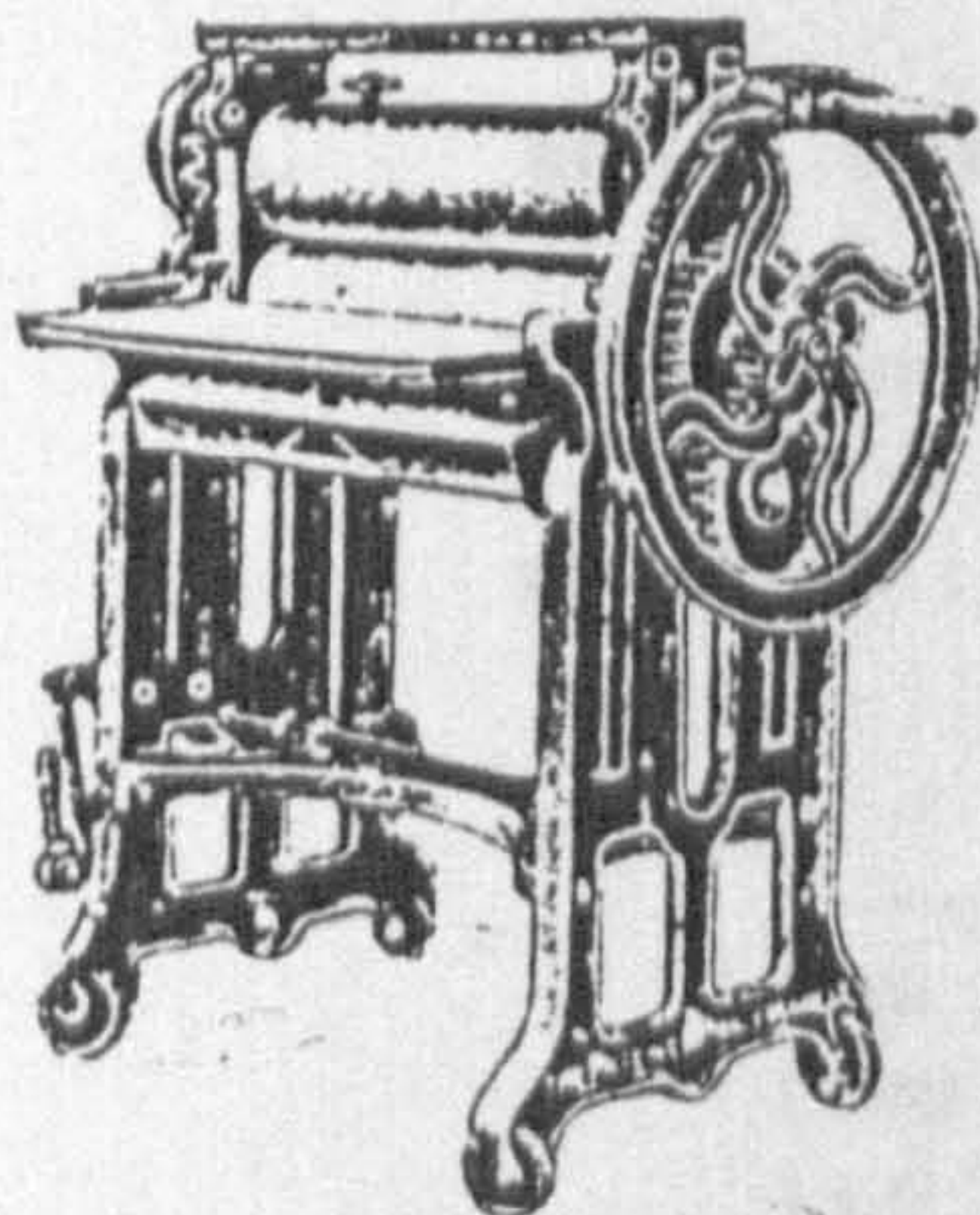

Fig. 2.

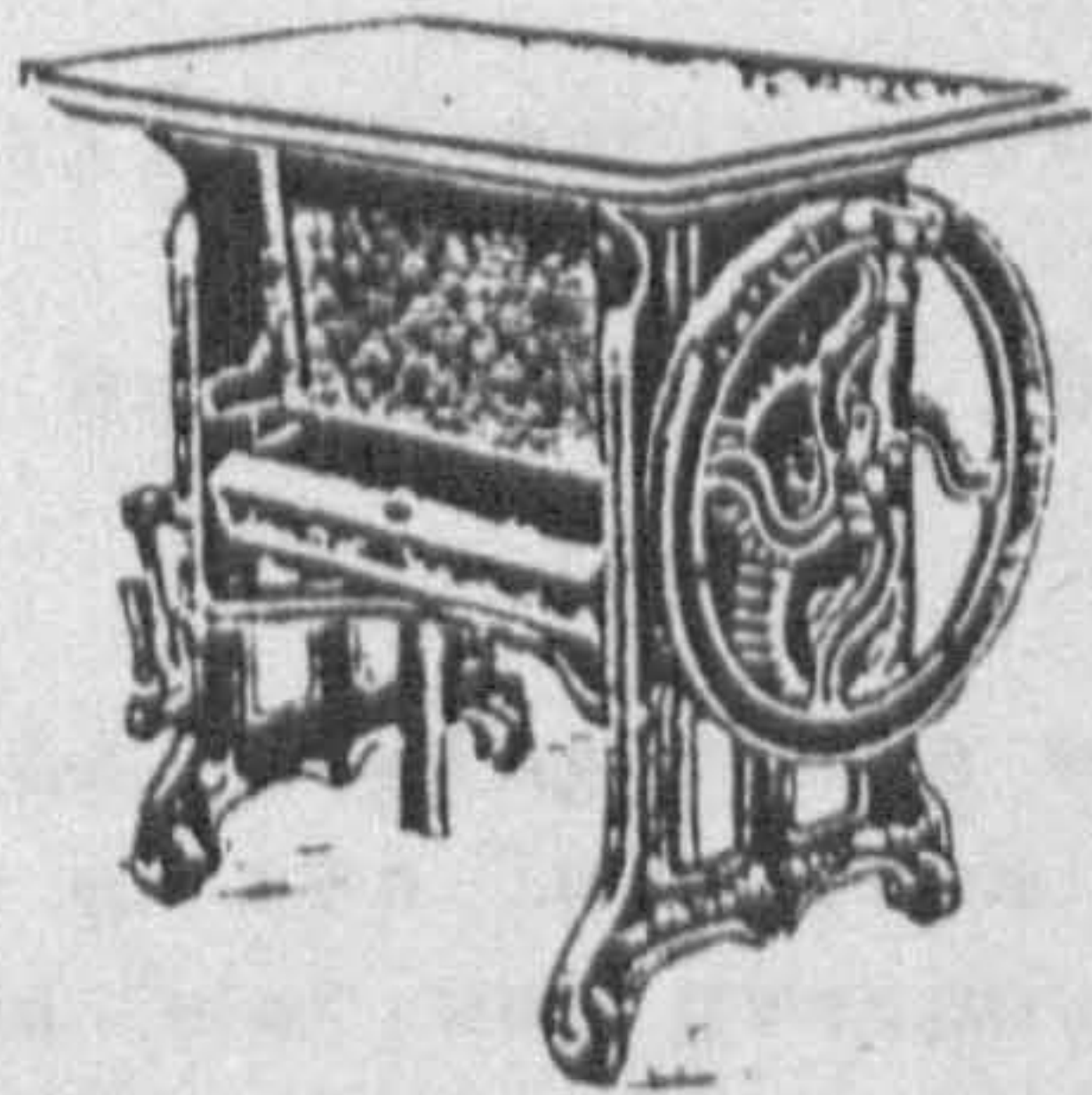

Fig 1

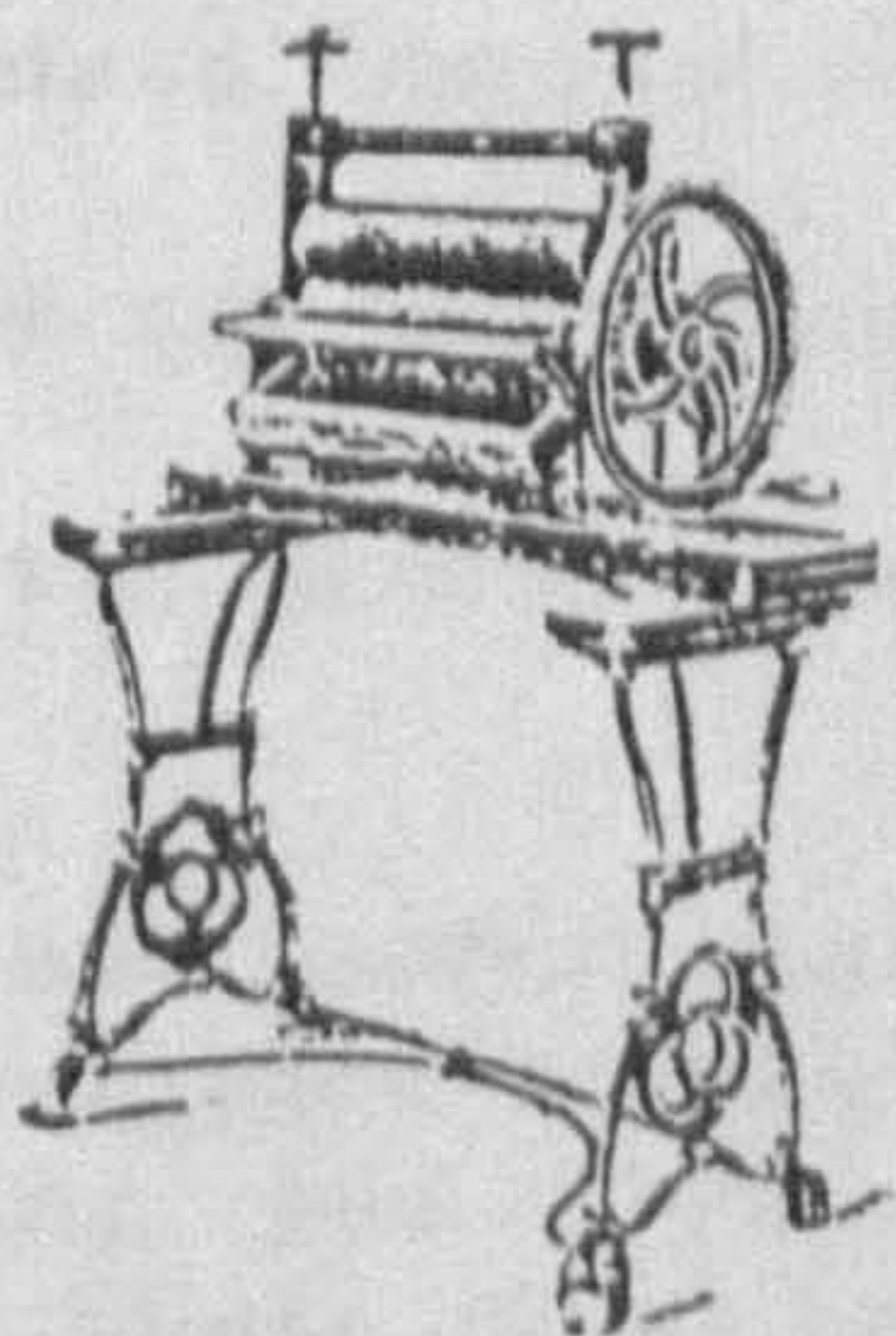

Fig 3

Wringing and Mangling Machine and Table combined. Fig. 1 shows the Wringer folded under table. Figs 2 and 3 show it in position ready for use. No portion has to be removed when making this change.

The height of the table is 27½ ins., and dimensions of table top 36½ by 20½ ins., therefore it should be found useful in kitchens, &c. where space is a consideration.

As Figs. 1 and 2, with Rollers, 20 by 5½ ins.

" " " "	22 " 5¼ "	" " " "	24 " 5¼ "	" " " "	20 " 6 "	" " " "	22 " 6 "
---------	-----------	---------	-----------	---------	----------	---------	----------

49/9	51/9	56/6	52/9	55/0
------	------	------	------	------

As Figs. 1 and 2, with Rollers, 24 by 6 ins.

As Fig. 3, with Rollers, 15 by 3½ ins.

" " " "	18 " 3½ "	" " " "	20 " 3½ "
---------	-----------	---------	-----------

57/0	50/3	51/6	56/0
------	------	------	------

The Ewbank Duchess
To order only

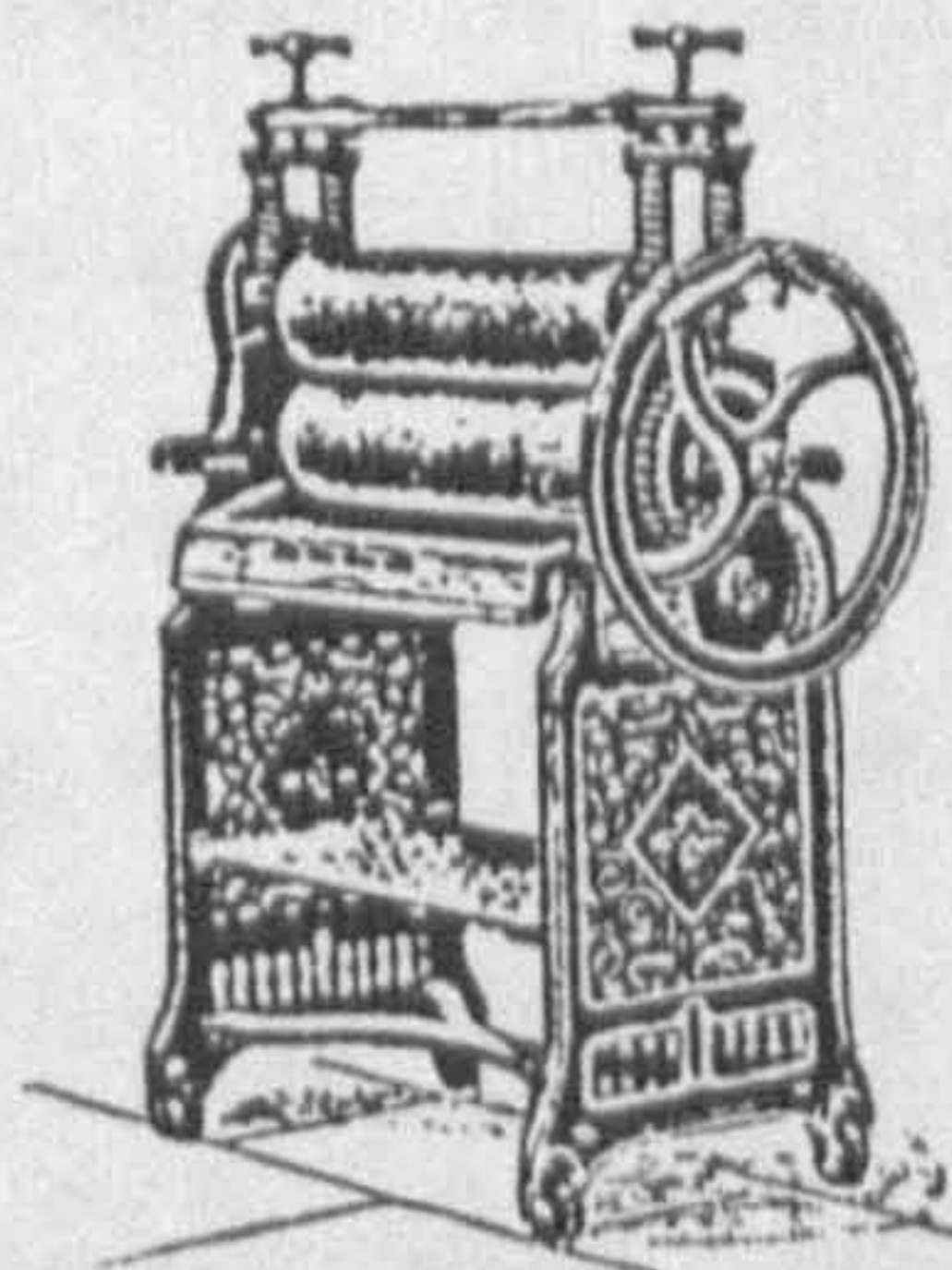

21 in. 40/9 24 in. 42/3 27 in. 49/0 30 in. 55/9

The Ewbank Queen.
To order only

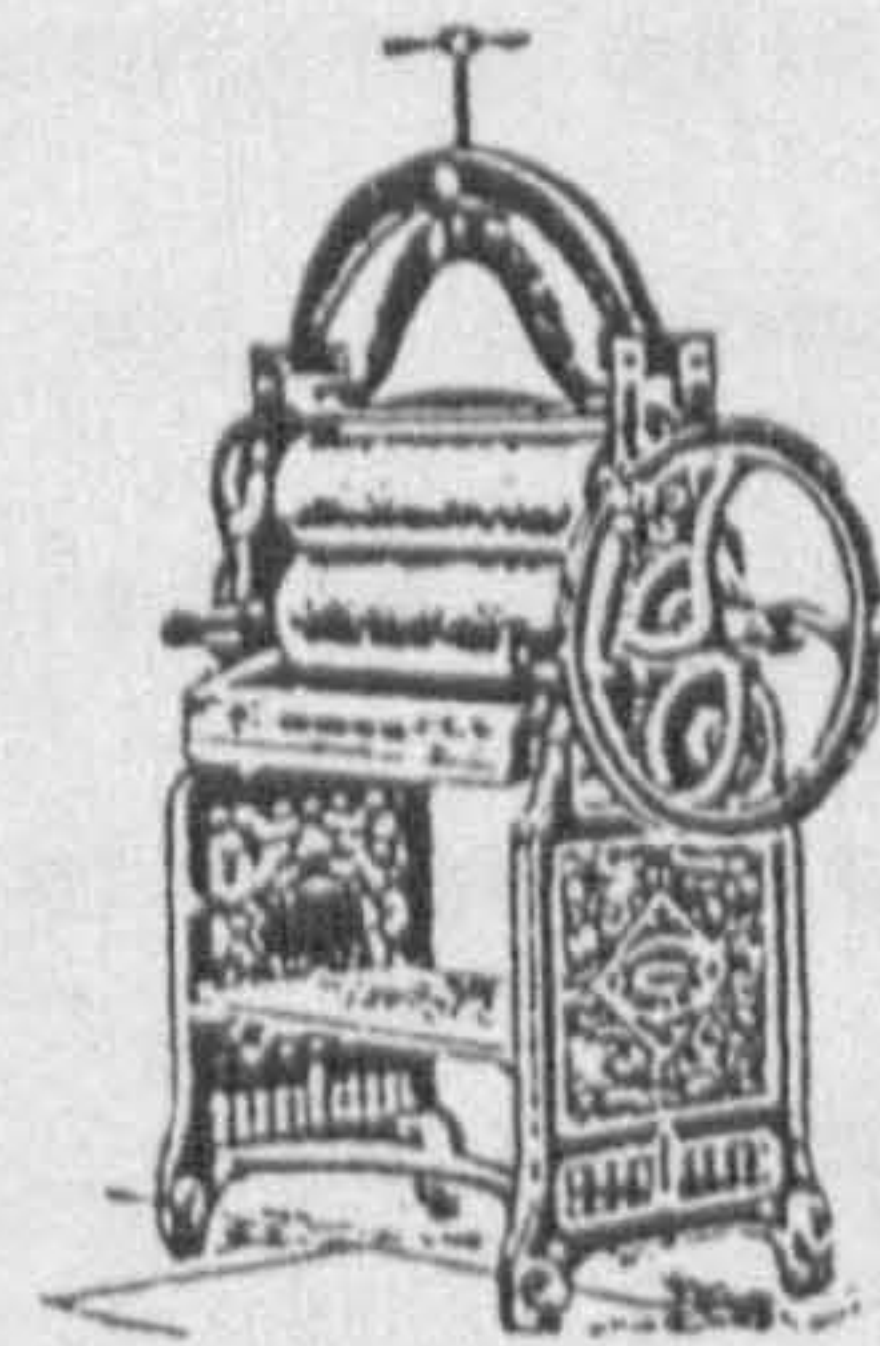

21 in. 39/9 24 in. 41/6 27 in. 48/3 30 in. 55/0

The Army & Navy Table Mangle.

(To order only.)
Suitable for flats and other places where room is a consideration. With Patent Safety Bolt.

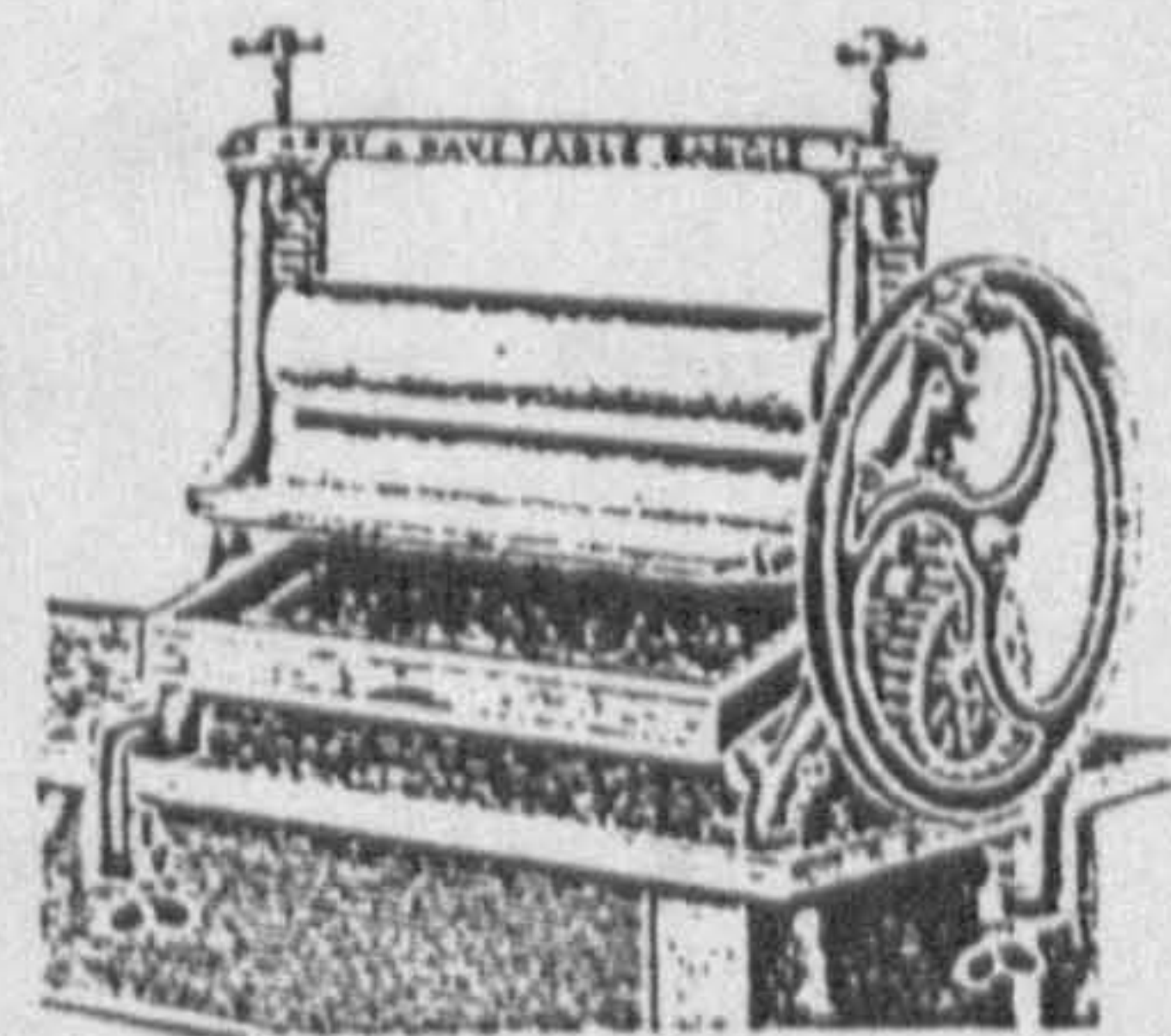

(With folding handle and two malleable iron fixing clamps.)
Rollers - 18 in. 18/3 20 in. 18/6 22 in. 18/9 24 in. 19/0
Brass capped .. 17/6 17/9 18/0 18/3
Carrriage paid to any Railway Station in the United Kingdom

The President.

Galvanized frame, indiarubber rollers, 12 in., to clamp to tub only 14/4
Do. do. 14 in., with drip board, to clamp to tub or table ... 18/0

WASHING, MANGLING, AND WRINGING MACHINES are not kept in stock. Obtained to order only, and forwarded direct from manufacturers. Purchasers are particularly requested to refuse the acceptance of any machine tendered by the railway company or carriers in a damaged condition, and advise the Secretary of such refusal.

Ironing was the most skilled sequence in the laundry process and it required training and experience to reach a satisfactory level of performance. It was far more labour intensive than the other sequences. The ironers were arranged in rows at tables around the walls and in the centre of the room. Photographs 8 - 12 depict the ironing rooms at Snaresbrook (c.1924), Finchley (1901), Saltash (1919), and at the two Liverpool convents of Wavertree (1902) and Ford (c.1890). Some of the tables, usually those in the centre, were of varying lengths and widths to facilitate the ironing of awkward garments. Flat irons were used and were heated on special stoves at the end of the room. The heat from these stoves was fierce, not to mention that from the irons themselves. If the drying closet and furnace were in the same room, the atmosphere was frequently overwhelming, especially as the garments hanging overhead reduced ventilation. The removal of the drying closets to a separate room was an early development. By 1860 the Hammersmith sisters had further alleviated the problem by building a separate but adjacent stove room with convenient access. Bristol followed suit in 1875 but ironing remained hot work and the separate stove room did not become a standard feature in the other Good Shepherd laundries until the early years of the 20th Century. When a new laundry was built at Hammersmith in 1886 the sisters were greatly put out:

'.... the ironing stove was most unfortunately put at the end of the long room and inside the building so that the heat was overpowering, and the distance half the children had to walk for their irons was a great consideration in the wear of their clothes, fatigue of their bodies and the loss of time. To obviate all this we had to build a stove room at the side of the laundry.'

(22)

That did not happen until 1890. The intervening four years must have been exceptionally long and wearying for the penitents. At Manchester they solved the problem in a different way:



Photograph 9: The Ironing Room at Finchley 1901



Photograph 10: The Ironing Room at Saltash 1919



Photograph 11: The Ironing Room at Wavertree (Liverpool) 1902

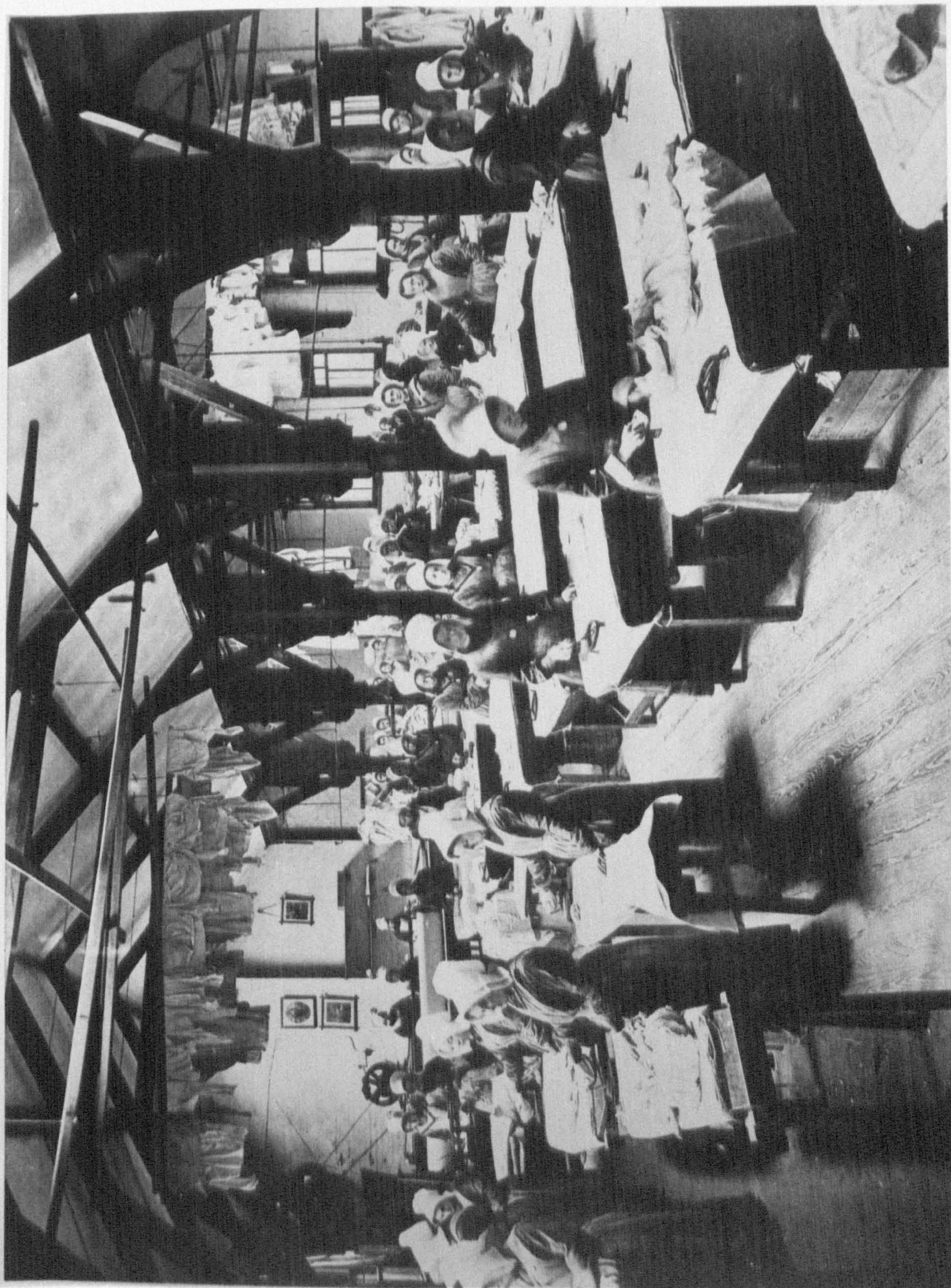

Photograph 12: The Ironing Room at Ford (Liverpool) c.1895

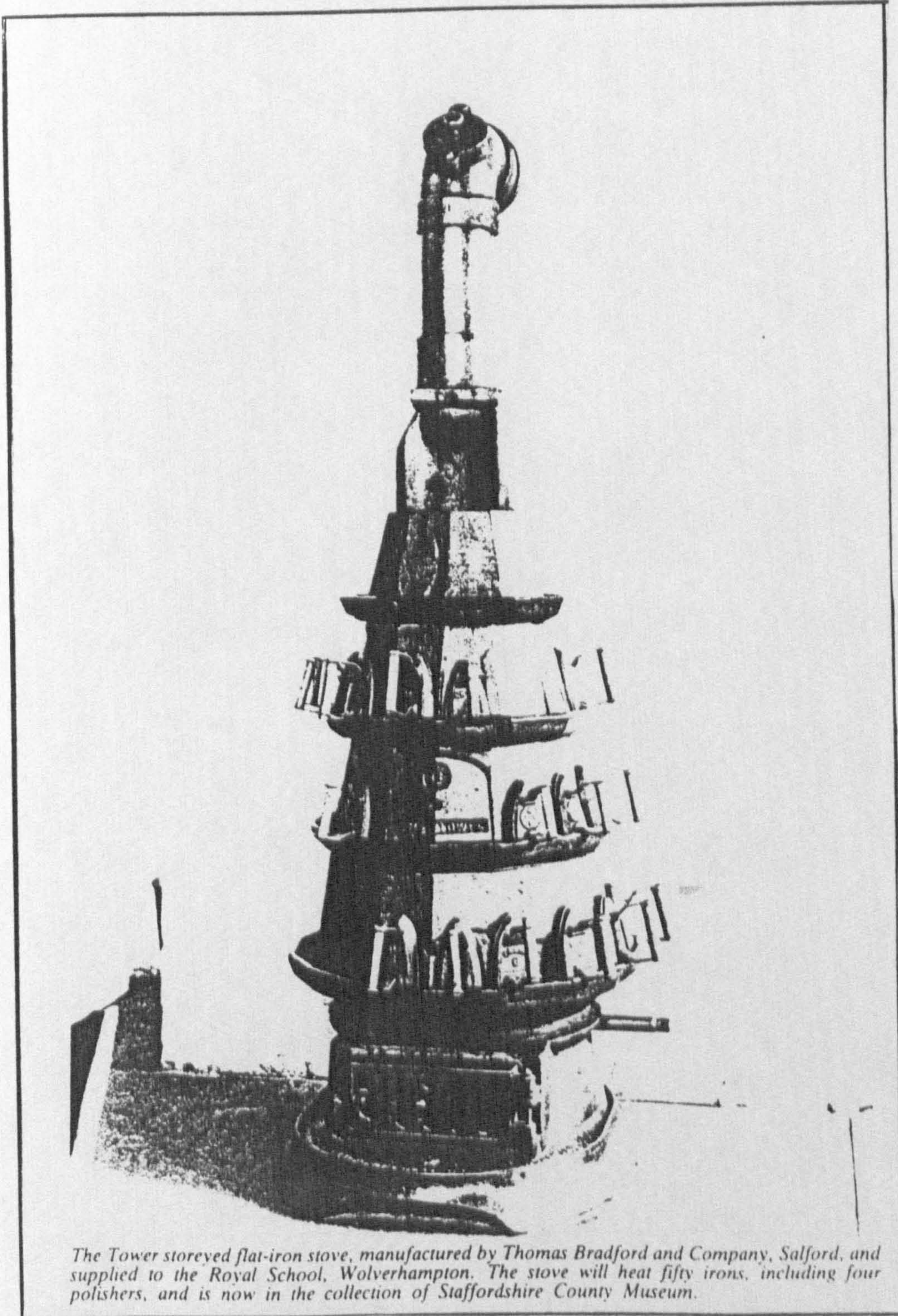

The Tower storeyed flat-iron stove, manufactured by Thomas Bradford and Company, Salford, and supplied to the Royal School, Wolverhampton. The stove will heat fifty irons, including four polishers, and is now in the collection of Staffordshire County Museum.

'The laundry being very much overcrowded since the increase of numbers was almost suffocating. We were now able to improve it very much by running up a large ventilating tube, through the dormitory and out into the roof, which carried off much of the bad air.'

(23)

Ironing was not simply a matter of smoothing and folding washed clothing. It also involved the glossing of starched items and the crimping and goffering of caps, collars, cuffs, and ruffs. These jobs were reserved to the more skilled ironers and a range of specialised irons and ancillary equipment was available for their use.

After the initial sorting of the soiled linen and its removal to the washroom, the packing room would have been cleansed in readiness for the newly laundered items. The packing rooms at the two Liverpool magdalen asylums are shown in Photographs 13 and 14. There was usually a small ironing stove and some ironing boards and small clothes horses for the last minute ironing of fine items wrongly creased or crumpled in the packing. The packing room was normally arranged with deep divided shelving along one or two walls, rather like an outside set of pigeon holes. Space was left above for the storage of empty laundry hampers. Along the remaining walls there would be counters with a similar divided shelf arrangement beneath. There would be a few movable trestle tables in the centre of the room but most of the floor space was left available for the hampers being filled. The finished work was brought from the ironing room or mangling room in open wicker baskets. Much later these were replaced by special trollies.

The sorters and packers were the first to start and the last to finish. This was particularly hard on them as contract work increased and family habits changed, for this meant that the laundry cycle could be started on different days of the week or reduced to meet contract deadlines. It was not unusual for penitents and sisters to sit up



Photograph 13: The Packing Room at Wavertree (Liverpool) 1902



Photograph 14: The Packing Room at Ford (Liverpool) c.1895

The Sensible Sad-Iron with Stand.



Nickel-plated, 4 in. 0/10
 .. 5 1/2

The Ideal Iron.

For all kinds of light fine work.



Nickel-plated, 4 in. each 1/1
 .. 4 3/4 in. 1/9

The "Rapide" Goffering Iron.

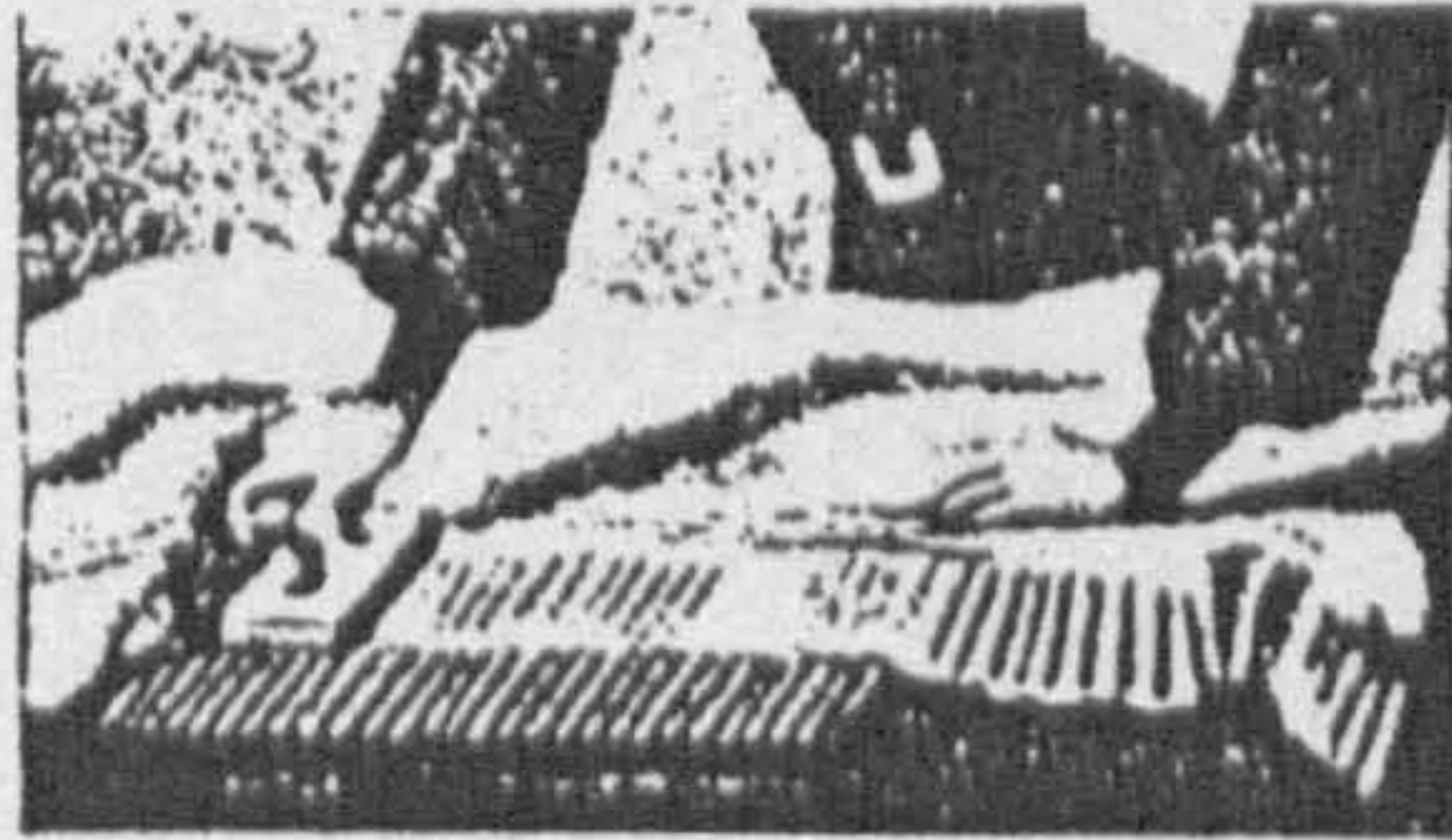

This new system supersedes the goffering tongs, and is most useful.

No. 0, about 3/8 in. flute each 6/9
 .. 1, .. 1/4 .. " " 6/9
 .. 2, .. 3/8 .. " " 6/9

Cold Handle Sad-Irons.

(Mrs. Pott's Patent.)

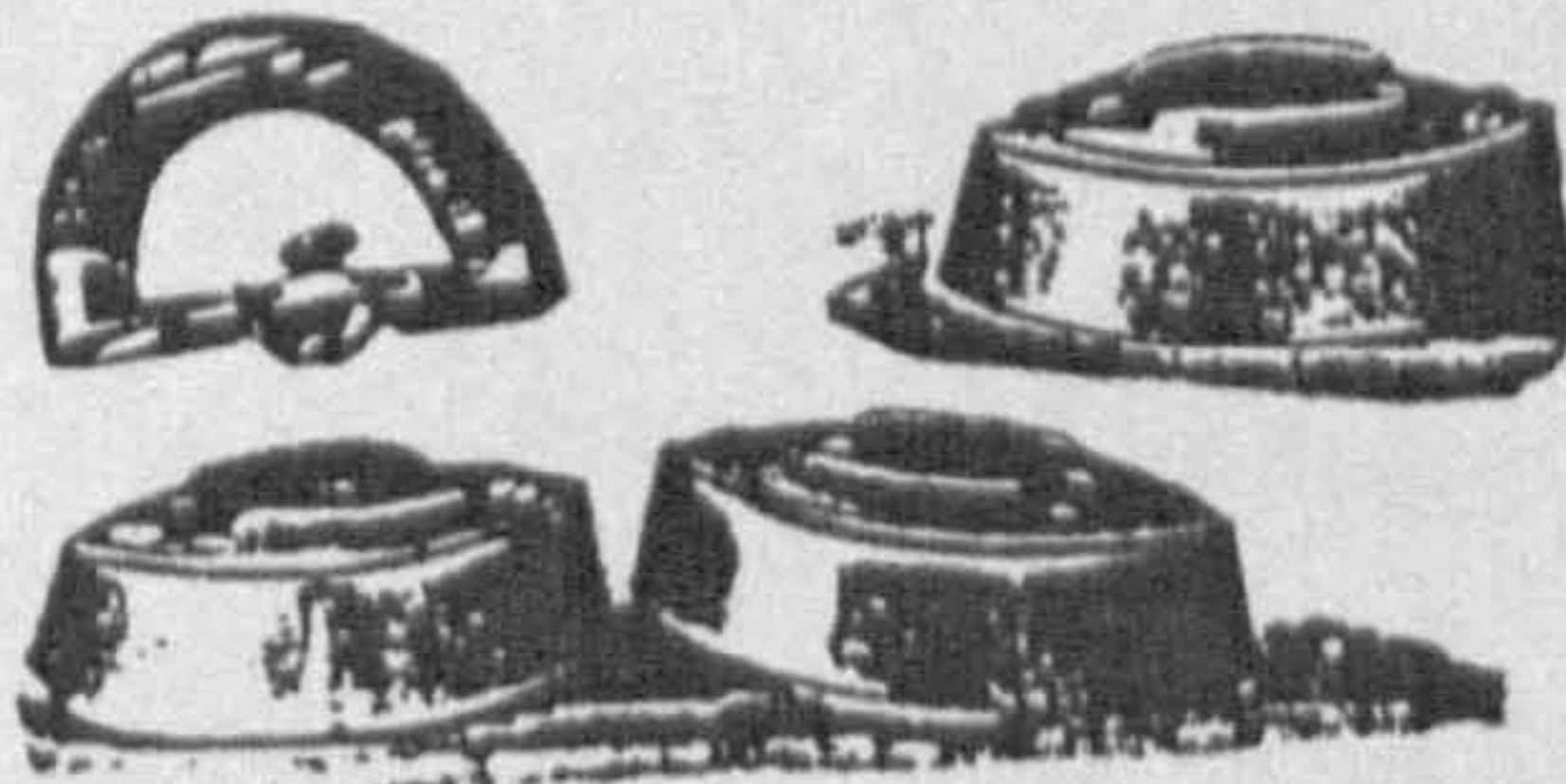

Nickel-plated.
 Per set 3/10

Self-Heating "Dalli" Box Iron.

It keeps the iron in constant and intense heat so that the ironing need never be stopped or interrupted to heat the iron.

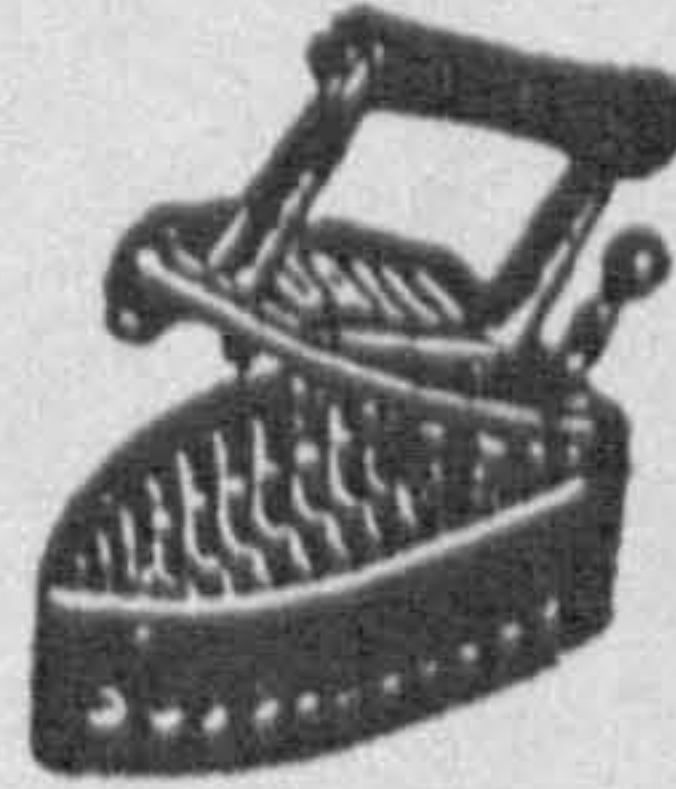

Each 6/0
 Fuel, box of 128 blocks 1/9

Irons, box, best steel faced, with two cast beaters 4 1/2 in. 2-9 5 in. 2/10 5 1/2 in. each 3/7
 Extra beater, for do, per pair 4 1/2 in. 0/3 1/2 5 1/2 in. 5 1/2 in. 0/6 1/2
 Wrought iron do, each 4 1/2 in. 0/7 5 in. 0/9 5 1/2 in. 0/11

Hat Irons.



Irons, hat brim, solid each 1/0 2/0
 Do do, nickel plated, each 1/1

all night to pack the linen due to be sent out the next day. This happened in the early days when throughput was slow or work had to be repeated due to lack of experience. In the highly developed phase it occurred when the entire laundry for an ocean-going liner or an hotel might have to be completed within two or three days. (24) A sense of order and arrangement combined with a calm temperament were essential qualities for the packing room. Here the sense of meeting a deadline was most acute. Both quality control and accurate sorting were essential to retaining custom. It was not without its humorous side. At Cardiff it was recorded in 1874:

'A curious incident occurred in the laundry which shows what trifles might make mischief. We have the washing of a family named "Coward". The label for their things got turned and another direction put on the other side and sent off in the packet of a youth in an office who sends his washing here. The next week a letter of four pages came to enquire what we meant by writing such a word on his label. He had "never treated you ladies with anything but the greatest respect" and should be glad of an explanation and a stamp enclosed for an immediate answer. We were highly amused at the importance of the letter.'

(25)

The uncrumpled arrangement of a variety of items in one container and in a manner that would ensure an immaculate condition when unpacked was a special art. It was a very responsible and skillful job never to be replaced by mechanisation. On the death of a laysister at Finchley in 1904 it was noted:

'(She was) employed with the children chiefly in the packing room where her intelligent and clear mind enabled her to be useful.'

(26)

It is not surprising, therefore, that the regular packing room staff was augmented during hectic periods by the choir sisters. They were literate and educated women, which the laysisters frequently were not.

Although conditions and events in the packing room were never of the excessive or rather dramatic kind experienced in the other areas, life there was not without its problems. These were usually due to architects or builders who were either poorly instructed or had no inkling of laundry requirements. At Finchley the architect simply forgot the packing room altogether and at Hammersmith:

'The fact was, the new packing room had been built so exceedingly small, there was room for the work and cases, (but) our poor sisters employed there had to sit up at night to pack. Besides this, the soiled linen had to be counted and sorted in the old packing room at the other side of the house. Here was a double inconvenience for the Children's Refectory became a passage to take the linen to the wash-house; the dirt, disorder, and waste of time were all very undesirable. By some extraordinary mistake, the flue of the drying closet opened into the packing room and when it needed sweeping it had to be done there. The drying closet was worn out and so delapidated that it was considered dangerous.'

(27)

All the convent laundries employed a van-man with horse and cart for collection and delivery. This was determined by the nature of the enclosure as much as anything else, for in the early days at Hammersmith the *tourière* sisters had touted for needlework. Although the weight of the hampers might have been a major consideration, it must be remembered that both sisters and penitents were used to carrying baskets of heavy sodden articles around the laundry. Hammersmith were lucky in their choice of Daniel Geraghty, but it was frequently difficult to find a reliable man. The initial outlay on a horse and cart were heavy charges in the period before a steady custom had built up. At Manchester the nuns hired an old man with his own horse and cart, but he turned out to be very disreputable and irregular. They were helped out of their quandry by a roman catholic baker who lent them an omnibus which could take eight laundry baskets. They still had to hire the horse and driver to go with it. It was not until

1873, eight years after the start of the business, that the Manchester nuns were able to afford their own horse and cart, stable, and van-man. (28)

The manpower and staffing of the laundry are difficult to determine, especially so far as the penitents are concerned. The written accounts of all the convents make it clear that in the early days the total combined strength of the nuns and penitents was inadequate and night work was common. At Hammersmith the sisters once worked two or three nights a week for three months. (29) The ultimate responsibility for the laundry rested with the Mistress of Work, and she was answerable to the Mistress of Penitents. As the Magdalen Asylum grew in size the Mistress of Work often delegated responsibility for the laundry to a choir sister who was variously described as 'In charge of the books' or as 'Laundry Superintendent'. Whether the Mistress of Work did it herself or not, the post was always nominal so far as the actual conduct of the laundry was concerned. It involved no more than keeping the accounts. The real operational responsibility for the work rested with the lay sisters who were engaged in the laundry regularly. From the beginning of the Hammersmith laundry in 1844 there were always two such sisters at least, one appointed to the wash-house and one to the laundry. When necessary all the sisters helped with the sorting and packing. Later as work and numbers increased, the wash-house sister and the laundry sister were assigned permanent assistants from among the other laysisters. When the laundries developed further, particularly as the sequences became physically separated in different rooms, lay sisters were assigned to take charge of the mangling room, the ironing room, and the packing room. The drying room appears to have remained the responsibility of the ironing room sister and her assistant. From the start, the lay sister in charge of the work was recognised as crucial. When the lay sister who held that post at

Manchester died in 1874, Mother Weld, the Provincial Superior much bemoaned the loss and went on to comment:

'..... a most important post for our houses which gain their bread mostly by this means'.

(30)

At Hammersmith in 1877, the year in which the laundry converted to steam power, there were 31 nuns, 5 tourière sisters, and 12 novices. Apart from the sole choir sister who kept the books, the permanent staff consisted of 5 lay sisters, of whom one had charge of the washing and the remainder were distributed in the laundry. They were assisted by 4 of the 5 lay sister novices. In none of the Good Shepherd laundries did the permanent staffing ever rise above five and a careful examination of the profession registers indicates that they were always lay sisters. Help from the novices was only available at Hammersmith, and from 1886 only at Finchley. Even at the two-laundry convents, the overall laundry operation was still conducted by no more than 5 lay sisters. Throughout the period the basic division of wash house and laundry was maintained, and never more than one sister was in charge of a magdalen asylum wash-house. (See Appendix 6)

The size and stability of the work force is difficult to assess with precise accuracy as no records of the penitents' work assignments were kept. The entrance registers record admissions chronologically and departures were noted against these initial entries. There were no formally recorded tallies of total numbers in residence at specific dates, except intermittent end of year counts between 1856 and 1869. Such figures were sometimes mentioned en passant in the convent annals and usually so in the community letters, but the letters became infrequent and stopped altogether in the late 1880's. It is possible to calculate the number of penitents in residence on 31st December for any annual cohort of admissions, and to determine the length of stay and turnover

for the same group. This has been done from the dates of foundation to 31st December 1911 for the four magdalen asylums whose complete sets of registers are extant, Hammersmith, Glasgow, Bristol and Finchley. A more detailed analysis of turnover has been calculated for the first year of each decade, and set out at Appendix 1. A detailed profile of the annual cohort of admission at Hammersmith has been constructed for 1878, 1888 and 1908, and a complete reconstruction has been achieved for all the penitents resident at the end of 1866. This data, set out at Appendix 2 and discussed in Chapter 3, is analysed further below.

Apart from its sequential nature laundry work has certain other characteristics which need to be borne in mind when discussing the work force. Foremost among these was the unpredictable volume and timing of the work and its seasonality. In London laundry work generally peaked in May and June during the social season and again in October and November when Parliament opened. This was true both of domestic custom and hotel contracts. To a certain degree this would have been offset by other institutional or commercial contracts. At the ports the rapid turn-round of ocean going vessels and the associated demand for hotel accommodation tended to produce episodic pressures on the laundries far more intensive than anything experienced at Hammersmith. The weather had a considerable effect on the volume of domestic custom, sudden fine spells causing a significant increase. Although the busy season was predictable in general terms, there was considerable variation within those months. Convents like Manchester, which relied heavily on lower middle class domestic custom, were particularly vulnerable to changes in the employment situation. During trade depressions this group of customers, owners of small businesses or highly skilled craftsmen, would tend to exercise their first economies by withdrawing

laundry and doing it themselves.

The over-time consequent upon seasonality and unpredictability was endemic in the laundry trade and the Good Shepherd establishments appear to have been no exception. (32) This was one reason for the very fierce general opposition to the laundry clauses of the 1895 Factory Bill. Despite allegations of sweating, it is interesting to note that Mary Abraham's pre-legislative investigation of the charitable laundries led her to conclude:

'The hours worked are similar in arrangement to that of a leniently conducted factory and workshop. The only evening over-time referred to was that which is sometimes worked before Bank Holidays to clear away work in order that the following day should be free. And it was stated that when there are sufficient girls in the Asylum this is very slight The over-time was not because of other household tasks but because of the volume of work and this is the same with all laundries.'

(33)

It may be that the overtime was more extensive than that admitted to the Lady Chief Inspector of Factories. Five years before Mary Abraham's report, the London Women's Trades Council had informed the Home Secretary that 16 hours a day was not uncommon:

'The women desire to particularly direct his attention to the injurious effects upon the women themselves and upon their families of such excessive hours of labour. Long hours in heat and steam predispose to intemperance.'

(34)

Yet, as the Chief Inspector pointed out then, the irregularity of the work and the pressure for rapid completion were considered to be such basic characteristics of the trade that legislation had been considered impossible during the major consolidation of the factory acts in 1878. (35)

To sequential process, variable volume, and rapid through-put, must be added the labour intensive nature of the work. Even when

calenders and washing machines were introduced, a great deal of washing and laundry was done by hand. Unlike many other forms of mechanisation, laundry machines required a high degree of human co-operation. A steam driven calender could require the undivided attention of four workers, where one or two would have sufficed at a hand worked mangle. The smaller specialised ironing machines required exactly the same man-power as manual ironing. Hydro-extractors and washing machines still had to be fed and discharged, and drying apparatus loaded. The mechanisation of sorting and packing was beyond human ingenuity and no method had yet been found to automate the exchange from one sequence to the next.

It only remains to consider the quality of labour force generally necessary to laundry work. In the trade at large, except in the small laundries, there was no interchange of employment between the three main categories of washers, ironers, and sorter-packers. (36) This was basically true of the Good Shepherd laundries also, although the more permanent among the penitents were likely to have progressed from washing to ironing, and possibly to packing and sorting. These progressions apart, penitents would remain within their categories. Washing was unskilled work requiring very little instruction and well within the normal capacity of any penitent. The finer points of water temperature, duration of wash, type of soap or bleaching agent, were matters for the sister in charge. Ironing was more skilful, but the basic technique of flat-ironing could be learned quite quickly and improved with experience. The more specialised ironing required an aptitude and more training and practice. Where machines were involved, both in washing and ironing, the longer-stay penitents were usually in attendance. Packing and sorting required more intelligence and basic literacy. In the trade at large it attracted women of a higher

(37)
 social standing than the washers and ironers. It has already been noted how even the choir sisters would be engaged in this work during hectic periods. Overall, laundry work was considered to be low grade employment with a largely unskilled workforce, but involving a cadre of longer serving skilled employees.

The basic characteristics of laundry work can thus be summarised:

1. Sequential Process
2. Variable Volume
3. Rapid Through-put
4. Labour Intensive
5. Largely Unskilled Workforce
6. Small Cadre of Skilled Workers

Their compatibility to the objectives, organisation, and activities of the magdalen asylum will now be examined.

The sequential nature of laundry work was admirably suited to the classification and separation requirements of the magdalen asylum and to those of the more complex multi-class Good Shepherd establishments. The temporal and spatial separation of the sequences fitted the discrete block deployment of the classes. At Bristol, for example, two separate laundry departments were built in 1864 for the reformatory school girls and the penitents, but a common wash room was retained. The girls used it on Mondays and the penitents for the rest of the week. Prior to that the two classes had used the facilities on alternate
 (38)
 weeks. Even when two different classes worked at the same time, they could be kept separate. Initially at Brook Green the women convicts
 (39)
 worked in the washroom and the penitents in the ironing room. One class could be withdrawn for recreation, prayers, or needlework, and another put in its place with a minimum of fuss. In other words there was near complementarity between the work and the division of the

inmates into classes. Sequential work and the imperatives of classification and separation were congruent operations.

Variable volume and rapid throughput, with their demand for long hours, might at first sight appear to be inconsistent with the orderly conduct of institutional life in a Good Shepherd establishment. However, even after allowing for some understatement to Mary Abraham, who in any case was not a gullible woman, and a degree of evasion with the factory inspectors after the 1907 Act, over-time and night work were more typical of the convent laundries during the early period of development than during their established and successful operation. In the early days the long hours were more likely to have been the result of lack of experience and technical hitches than of anything else. In the sequential context, although a greater volume of work would lengthen the washing and laundering hours, it was more likely to have been the final sorting and packing which would have spilled through the outer limits of the daily timetable. The 1907 Factory Act also recognised this difference by allowing the Packing and Sorting Room to be treated as a separate department for the purposes of the Act. Moreover, the effect on the penitents was off-set by the fact that in those circumstances the choir sisters would be drafted into the packing room, and it was not unknown for them to work all night. (40)

When wholly exceptional rushes occurred and the penitents worked longer hours, washing as the first sequence could still be kept within the institutional timetable. It was the ironers who would be worked into the night. This happened only rarely and the penitents involved were those who had been longer in residence, either through the remorseless attrition of institutional life or because of a commitment to secure their own salvation through a permanent co-operation with the sisters. For the penitents a radical break with routine served as

a diversionary release mechanism rendering institutional life more tolerable whilst simultaneously pointing to the need for order. Even little breaks with routine were occasions for excitement as the annals frequently record. Such a situation also united the inner cadre of penitents in the esprit du corps of an unexpected challenge surmounted and a job well done. Sometimes the exception became the rule, as at Bristol in 1852:

'Sister Assistant had become very tired especially as the Children had got into a very inconvenient manner of doing their laundry work by staying up at nights. This was now differently arranged as the new Mother Prioress saw there was no real necessity, but only an inclination amongst the children. After a short time they were reconciled to the reformation and saw the benefit of it.'

(41)

The timetable was within the control of the sisters and the content of blocks of time could be transferred without disruption to the institutional pattern. The times for Mass and meals were immutable. The former as a matter of ideological priority and the latter as a matter of institutional logistics. There were four blocks of work:

1. Before Mass	50 mins
2. Between breakfast and dinner	3½ hrs
3. Before tea	2½ hrs
4. Between tea and supper	2½ hrs

It will be noted from the timetable (Appendix 6) that the recreation periods after dinner and after supper would readily permit an extension of working time should exigencies so require. This was totally within the nuns' discretion before the 1907 Act and was little affected thereafter. Under the Act women could work up to 14 hours a day provided there was no continuous period of work longer than 5 hours without a ½ hour meal break; and no work was to be permitted after 9 p.m.

The laundries worked well within these limits. Even if all the recreation time were used for work, the total working time would amount to 11 hours, 3 hours within the maximum provided by law. The sorting and packing could be done by the nuns, who were neither inmates nor employees within the meaning of the Act.

The wash house and laundry worked on different schedules. The wash house penitents worked the hours indicated above on a four day week from Monday to Thursday. The laundry penitents could not start until the first washing came through. They began the ironing after tea on Monday and finished at tea time on Friday. Only a few very large commercial laundries washed five days a week. Good Shepherd practice was typical of the industry as a whole. The capacity of the convents to meet unpredictable volume lay in their total control over the temporal disposal of the inmates and the reserve pool of nun labour that could be brought into the last sequence.

However much the institutional arrangements and principles may have fitted the sequencing, unpredictability, and rapid through-put of laundry work, there still remained the problem of labour supply and quality. The labour intensive nature of the work, and the largely unskilled operations of washing, mangling, and plain ironing would have presented few problems. Hammersmith had reached an inmate population of at least 100 by 1856, and by the end of the 1860's Glasgow, Bristol, and Liverpool had reached the same level. Finchley rose to 106 in 1877, and by the end of the century inmate numbers in excess of one hundred were quite common. In 1897 the Bristol annalist had recorded that the laundry was overflowing with work for the 180 penitents in the asylum. Ten years earlier when the laundry had been opened at Hammersmith, the penitents' refectory, dormitory, and church were enlarged to accommodate 200 women. It was specifically acknowledged

(44)

that the extensions were occasioned by the labour needs of the laundry. Such an investment in accommodation implied no lack of confidence in the availability of penitents. Cardiff had reached 120 within
(45)
 10 years of its foundation and accommodated 180 penitents in 1902.

It may be safely concluded from the available evidence that the quantitative supply of labour matched the demands of the laundries even at their highest peak of development.

Yet quantity alone is insufficient. Washing may have been unskilled, although one suspects that there were knacks, but it was certainly hard. It must have been even harder in the Good Shepherd laundries than in the secular laundries which generally relied on men for the dolly-tubs and mangles. Although the Good Shepherd laundries worked on a scale that could match even the most successful commercial laundries, they did not mechanise to the same degree, and even less so in the wash room. This was not solely determined by the availability of labour. Moreover, in the laundry trade the degree of mechanisation did not significantly affect the amount of labour required. The effect of extensive wash room mechanisation was to eliminate much of the hard labour of pounding, rubbing, and wringing. Apart from keeping capital expenditure down, the more likely reason is to be found in the continuing commitment of the nuns to the traditional idea of work as penance. Manual work was viewed as far more effectively transformative than machine minding, especially for the majority of women who came to the Magdalen Asylum. In 1852 Sister Emma Raimbach had written of the Hammersmith penitents:

'(The laundry work) certainly is profitable to the souls of those among the penitents who are restless and brought up to hard labour or who are very dissipated. To many a penitent to sit still for hours at needlework, mostly in silence, her companion her own grieved and irritated and perhaps remorseful thoughts, to sit with the other silent penitents is a purgatory and sometimes a very painful

'source of temptation. For such a one the ironing room or wash house is their security, whilst some preferring tranquility after the excitement of the world find rest and quiet a sure means of restoring the peace they had lost. In both the wash house and the class the hours of silence are enlivened by the spiritual reading, singing of spiritual canticles at stated times, and saying the rosary, and thus both kinds of labour are very advantageous in a large class of penitents, where varieties of character and circumstances, habits and conduct require a difference in the treatment.'

(46)

The heaviness of work in the wash room would certainly have required the women to be physically robust. At the very least, it would not have been work for older women. It was such hard work that voluntary inmates, such as were the penitents, might not be expected to stick it out for long. The high turnover typical of the laundry trade had been observed by Charles Booth in 1902 and again by the Prices and Incomes Board in 1971. Both had noticed that alongside this turnover there existed a core of workers with long service. We have already noted in Chapter 3 that there were 102 penitents at the Hammersmith Magdalen Asylum on 31st December 1866, 27 of whom had been among the 57 who had been admitted during that year. The annual turnover in that cohort was over 50% and most of those who left did so within 3 months. From Appendix 2: Table 1 it is clear that Hammersmith's annual turnover had been running well above 30% since 1852, except in 1883 and 1884, and was frequently in the 40% - 50% range. Appendix 1: Tables 1 - 5 reveal a consistent high turnover and substantial departures within the first months at Hammersmith, Glasgow, Bristol, and Finchley. During 1866, 1878, 1888, and 1908, the years selected for detailed analysis, the average age of the Hammersmith penitents admitted during the year was 22, 24, 24, and 29 respectively. Appendix 1: Table 3 shows that after 1876 the monthly average admission at Hammersmith ranged between 7 and 11 which was somewhat higher than

the magdalen asylums as a whole. Overall it would appear that the supply and quality of women admitted was such as to meet the immediate labour needs of the wash room. The women were generally young and no training was required to put them to work. Although turnover might be high in terms of the primary institutional objectives, it ran at a perfectly acceptable level for laundry work. It was probably far lower than in the laundry trade generally. Booth remarks upon the almost casual labour aspect of washing and that as many as 5% of institutional inmates had previous washing experience. The 1971 Prices and Incomes Board report on laundry pay and conditions commented on the constant high turnover in the laundry trade, which then ran at 72% for women. This is not to be taken as a valid statistical comparison between Booth's data and that of the P.I.B., but it is sufficient to indicate an endemic feature of any laundry work force.

The Good Shepherd laundries could not have survived solely on the basis of an adequate supply of penitents suitable for instant conversion into washerwomen. There were always some older women admitted, among whom there might have been some ironers. But even if all such women had been ironers, which was most improbable, their number would have been totally inadequate. Admittedly, some among the current admission could be taught mangle folding or plain ironing quite quickly, particularly if they were used as 'backers' to more experienced women. Fine and fancy ironing and packing were skills requiring much longer apprenticeship and experience. Consequently there was need of a cadre of skilled workers of whom the majority would have acquired their skills during a lengthy period in the magdalen asylum. The laundry work depended on their continual stability within the institution. The analysis at Appendix 2: Tables 5(a) - (9) of the 1866 profile throws light on this crucial element of the workforce.

Seventy-five women in the Hammersmith magdalen asylum on 31st

December 1866 had been admitted more than a year previously, compared to the 27 who had been admitted at some time during the year. Approximately one third of the 75 had been there for 10 or more years, another third between 3 and 9 years, and the remainder for one or two years. Apart from one woman of 65 years, all the women who had been there for 10 years were still in their late thirties or early forties. Twenty of the pre-1866 women were consecrated penitents and therefore committed to persevering for life in the magdalen asylum, and seventeen of them had already been there 10 or more years. Thus there was not only a substantial group of long-stay women but also an inner cadre of more committed women. All the long-stay penitents would have acquired good laundry skills, but the consecrated penitents were also entrusted with supervisory tasks. They were the cadre which gave stability and control to the workforce. Although the status of consecrated penitent was created to secure a deeper aspect of the religious objectives of the magdalen asylum, it came to serve the latent function of retaining skilled workers in the laundry. The other long-stay penitents, even allowing for the inertia of institutionalisation, could not be relied upon to remain to the same degree. They still, however, constituted a very stable workforce, especially when compared with the outside laundry trade. The profile indicates that 6 of these women later became consecrated penitents, 14 were found outside employment, usually in domestic service, six left of their own accord (one after 19 years), 3 were dismissed by the sisters, and 32 died in the institution, two in 1919 at 78 and 79 years old. As time went by the proportion of older women in this group would increase, but age was no bar where fine ironing and packing were concerned, and the 40 year-olds of 1866 were good for at least another 20 years in those occupations. The age structure of the laundry workers at

Hammersmith, although the product of a different logic, was entirely consistent with the age structure of the laundry industry as a whole.

There remains the question of the overall size of the laundry workforce. There is no written record of the number of penitents who actually worked in the laundry. New residential building was nearly always undertaken in relation to laundry expansion, whether this was pre-planned or otherwise. In most cases it is difficult to distinguish cause from effect. Except in the one instance at Hammersmith already cited, the sisters always maintained that the laundry work was to support the institution. Where the capacity of new accommodation is mentioned it is more likely to be in terms of what the institutional revenue could support. One cannot infer, for example, that the dormitory capacity is a prime indicator of the size of the laundry workforce, even though it might provide a notion of scale. A very small proportion of penitents would be incapable or unwilling to work. The latter would be dismissed very quickly. The former would be transferred to hospital or the workhouse if they could not be brought to health within a reasonable time, although long-stay penitents and the consecrates would be cared for in the Magdalen Asylum's own infirmary and tended until death if needs be. Some among the penitents would be assigned to domestic work in the kitchen or around the house, while others would be permanently engaged in needlework in the Class. A very small number would be put to tending the farm, garden, or dairy. It is by no means possible to infer workforce size from the statistical data alone.

It is possible to derive more precise figures from the plans and photographs that have survived. Photographs 6, 12, 14, and 3 depict the washroom, ironing room, packing room and Class at Liverpool during the 1890's. There appear to be 28 penitents in the washroom, 46 in the ironing room, 9 in the packing room, and 33 in the Class.

It does not seem unreasonable to assume that the photographs were taken on the same day. Even if most of the room was on the camera side, it is likely that most of the penitents would have crowded to the photograph side. ⁽⁴⁹⁾ Photographs 4 and 9 were taken at Finchley in 1901. It can be deduced from modernisation drawings that the whole of the wash room is shown. Here the penitents appear to stand at 40 in the wash room (there are 30 washing troughs), and at 31 in the ironing room. Photographs 5, 11, and 13 were taken at the second Liverpool convent, Wavertree, in 1902. The Liverpool and Wavertree proportions are similar, and given the size of the enterprise at Finchley, one might suppose only half the ironing room had been photographed. The photographs do not show the mangling or drying, but some of these processes would have been carried out by the calender machines clearly identifiable in Photographs 5, 6 and 7. Perhaps it may be inferred from this evidence that twice as many women were required in the laundry as in the wash room, a pattern confirmed by Booth's observations during the same period. Overall it seems likely that 70% - 80% of the inmates were employed in the whole laundry.

The steam mechanisation of the Good Shepherd laundries was begun at Hammersmith in 1877, and in this the sisters showed themselves to be well ahead in laundry development. Throughout the second half of the 19th Century small workshop laundries and individual homeworkers dominated the trade. There were some large hand laundries employing 80 or so women by the late 1880's, but mechanical factory laundries did not start to develop until the 1890's, despite the possibility of steam laundry machinery in the 1860's. The thirty year delay before any significant degree of mechanisation began to occur in the commercial sector was probably due to the existence of the large hand laundries for whom a ready supply of labour was available. Laundry work was

almost entirely female work, the proportion of women and girls ranging from 99% in 1861 to 93% in 1911. Mechanisation in the laundry trade was strongly resisted by the women's trade union movement and other organisations representing women. They thought it would extend the number of men employed at the expense of women. For whatever reason, the fact remains that the large scale mechanisation of laundry work did not occur until some 50 years after it had become commonplace in industry generally. (50) The Good Shepherd Sisters, however, are an interesting exception, and their introduction of steam machinery may well have been the pre-cursor of later commercial developments. A scaled reduction of the original installation drawing is inserted (51) at the end of the chapter.

It may have been the size of the Good Shepherd laundry business which brought them to steam power and mechanisation earlier than nearly all other operators. Some idea of the scale may be gleaned from the fact that in 1850 the laundry income at Hammersmith was already higher than the 1901 income of four of the six charitable laundries cited in the Fabian Society's tract 'Life in the Laundry'. While in 1901 the Ford laundry income was twice as much as the second highest on the list, and that at Hammersmith was higher again. (52)

The precise effect of mechanisation on life and work in the Good Shepherd institutions is difficult to determine. The installation of the steam engine, washing machines, and ironing machine at Hammersmith made no dramatic difference to the steady upward trend in laundry receipts, despite the substantial capital investment involved. Far from leading to a reduction in laundry workers, the number of penitents admitted in 1878 increased by 38% and remained at the higher level thereafter. The most notable difference was that annual turnover within the current cohort leapt from 37% to 62%, but even this movement settled back to broadly average levels in subsequent years (Appendix 2:

Table 1). Within the strict terms of Good Shepherd policy the admissions could be expected to increase as the purpose of an enlarged and modernised laundry was to support more penitents. At the same time, this larger number of penitents had to be provided with the work which was a central part of their programme of rehabilitation. The laundry neatly fulfilled both functions. A reduction in the workforce was no part of the policy and there were no wage costs, although total inmate maintenance costs would have increased.

Mechanisation certainly meant a redeployment of the workforce between the different departments, but this was not to the same extent as in the commercial laundries. In the commercial laundries the number of washerwomen was reduced drastically, and in some cases they were totally replaced by male machine operatives. In the Good Shepherd laundries the hand washing troughs were retained alongside the washing machines. As late as 1912, when the Finchley laundry was electrified,
(53)
all 30 hand troughs were retained. The machines were attended by women from the start, and the engine room itself was often supervised by a consecrated penitent. It is recorded of the engineer at Liverpool in 1885:

'Frances fell from a ladder and broke her collar-bone; she had had charge of the Engine-Room for many years and was most devoted to her task.'

(54)

The far greater speed and volume of washing led to a considerable increase in the penitents who were deployed to the ironing room. The mangling room generally disappeared as the mangles were replaced by steam driven calenders. The introduction of ironing machines was not nearly as extensive as in the commercial laundries and rarely went beyond installing one or two machines for ironing collars. Basically the Good Shepherd Sisters developed a dual system of machine and hand

washing alongside a totally mechanised mangling operation. Ironing remained very largely manual with gas irons coming into greater use by the First World War, although as late as 1906 Cardiff had installed a new ironing stove. For the Good Shepherd Sisters mechanisation meant a vastly increased speed of washing and mangling. This required a larger number of ironers and packers to complete a larger volume of work in the same time. In other words the laundry process becomes more continuous and hectic and this increased as laundry technology further developed.

The clear congruence between laundry work and the magdalen asylum in its organisational and labour aspects is persuasively supported by the evidence that has been adduced. The laundries in all the Good Shepherd magdalen asylums had become substantial commercial enterprises by the 1880's, a process which was accelerated by the introduction of steam mechanisation. Although financial self-sufficiency had long been a legitimate aspiration for monastic institutions, there always remained the uncomfortable paradox that the necessity of a material base tied an essentially spiritual undertaking into dependency on the secular world. The Good Shepherd laundries increasingly took on the character of organised factory production, thereby assuming a secularity of form readily recognisable to any outside observer. Whatever the sisters might have intended or wished, and we have no evidence to gainsay the sincerity of their perception of the industry as consonant with the traditional principle of transformative work, the outside world did not view it in the same way. It was not to be long before the very success of their commercial enterprise brought them into conflict with those who wished to bring the convent laundries within the purview of the Factory Acts. This challenge to their traditional ideological understanding of work, and their efforts to combat the threat, is described in the next chapter.

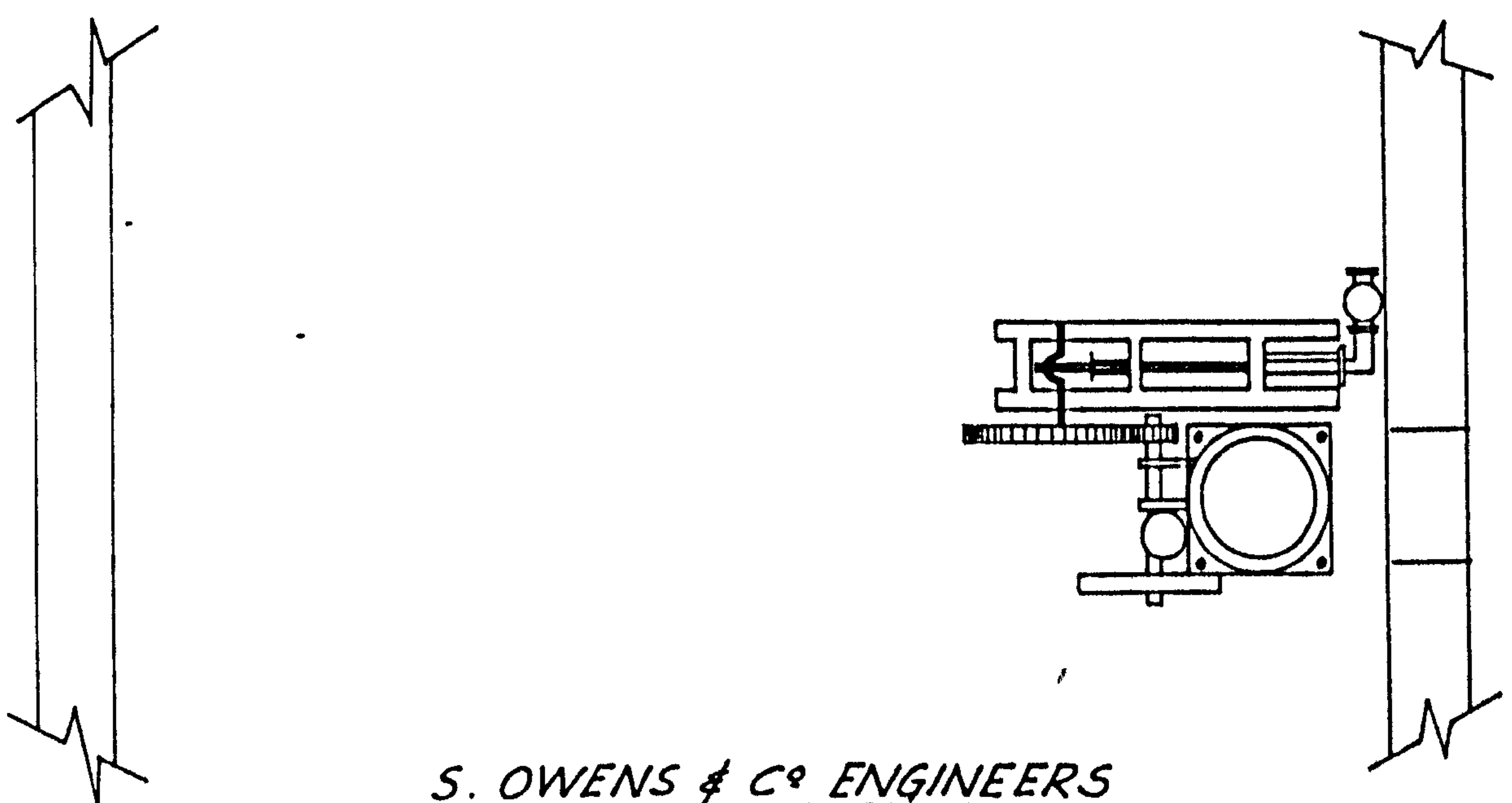
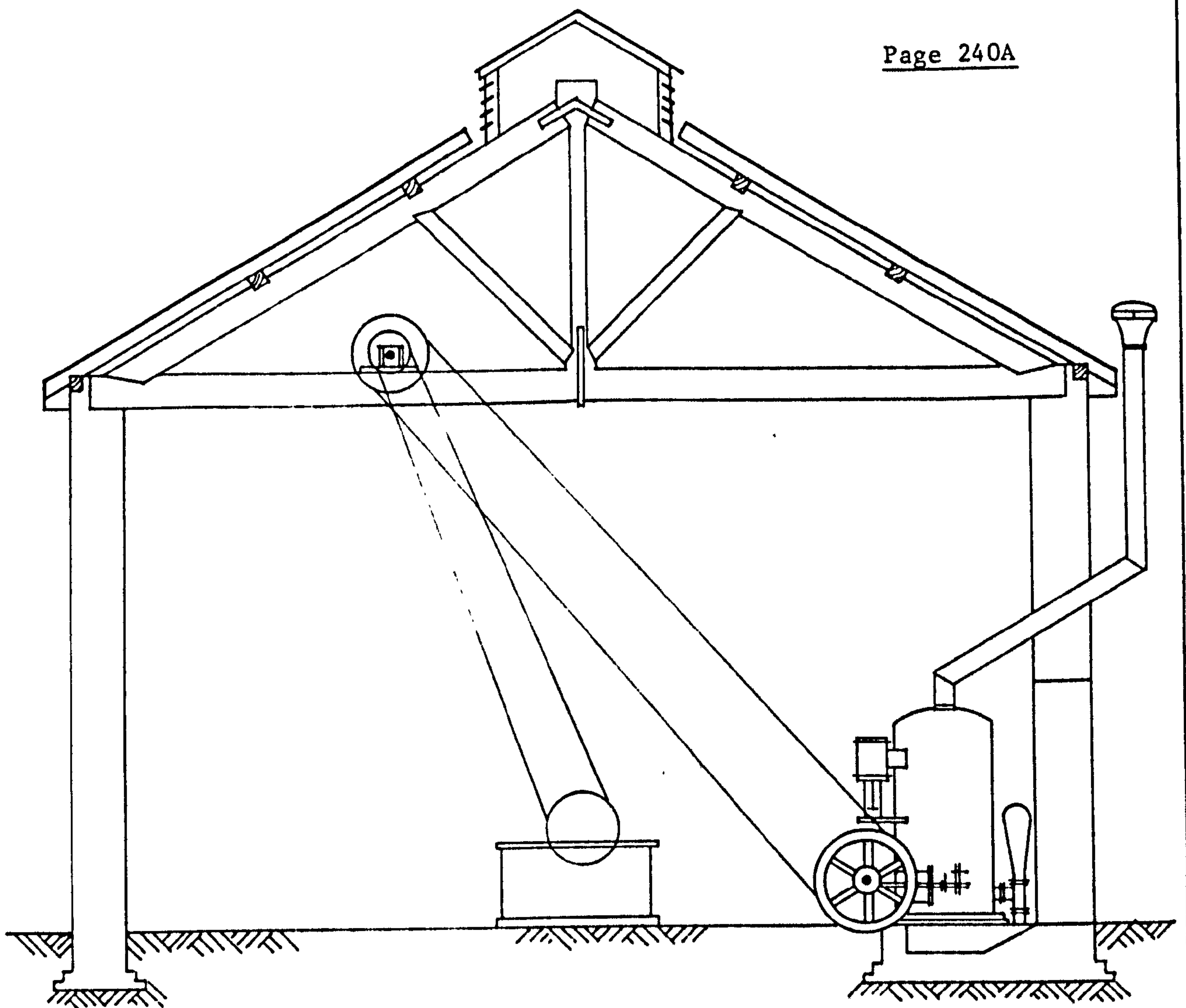

S. OWENS & CO ENGINEERS
LONDON

Arrangement of 2½ H.P. Vertical Engine and
4" Double Action Pump
Scale ½" = 1 foot March 8th 1877

Reproduction from the original



Approx. scale of reproduction.

CHAPTER 7: THE STRUGGLE FOR FACTORY ACT INSPECTION AND THE
PAYMENT OF WAGES

Despite their own perceptions and intentions, the Good Shepherd Sisters had been inexorably drawn into the concerns of the secular world through their engagement in laundry work. This is nowhere more evident than in the continual efforts to subject their activities and status to various kinds of legislative control. At heart, it was a conflict over the very nature of the magdalen asylum and the convent as religiously based transformative institutions, more particularly as places outside and beyond the purview of the secular world. This chapter is largely concerned with the politics of the question, but the surface enactments of government hide the deeper significances of the struggle to assert the superiority of differing conceptions of religion, morality, and work. There were many participants in the struggle and many modes of its expression: roman catholic and protestant, radical and conservative, the temperance movement, trade unions and employers, and an emergent women's movement. Each of these groups was working to establish the primacy of its own values and practices, and in the process elaborating its own crusading discourse. (1)

In Chapter 9 the symbolic aspects of these discourses are addressed directly; here we are concerned to recount their empirical substance, and the mode of their expression in political action.

Attempts to bring convent property and activities under public control or inspection were a recurring feature of Victorian life. In part they were a response to the somewhat strident roman catholic attempts to remove the few anomalous disabilities that remained after the 1829 Emancipation Act, in particular the illegality of charitable trusts for monastic purposes. (2) The attempts were oftentimes motivated

by an ingrained fear of romanism, a fear which was exacerbated by the manifest rapid growth of the Roman Catholic Church in England. Moreover:

'.... even if nunneries had not awed and at times aroused sexual fantasies among Victorian parliamentarians, the latter might still have found just cause to inspect and regulate them, just as the House of Commons had set into motion the inspection and regulation of lunatic asylums, factories and schools.'

(3)

The first major attempt to bring the convents under some kind of public supervision occurred when Dr. Thomas Chambers introduced a Recovery of Personal Liberty Bill into the House of Commons in 1853. (4)

The idea that women were somehow lured into convents, retained against their wills, and forcibly deprived of their property, held a firm grip on the mass of nineteenth century protestants. An idea that markedly contrasted with the reality; for women who entered the convent may have had a better deal than their married counterparts. They retained a 'radical dominion' over their dowries and property and often engaged in useful and responsible work. Chamber's Bill was defeated, together with a concurrent attempt to appoint a Select Committee 'To consider regulations, if necessary, for the protection of inmates of convents and their property'. (5) (6)

The Good Shepherd Sisters were well aware of what was going on and followed the proceedings with some trepidation:

'The dishonourable bill which would have been the destruction of Religious Houses in England caused so much indignation and disturbance that constant reports about it penetrated our quiet little enclosure, and great and serious was the anxiety which many of us felt.'

(7)

Hammersmith had been one of three convents visited by a small fact-finding deputation of M.P.'s. On that occasion, according to one

Member who cited her comments during the debate, Sr. Ouvrard the Superior had commented:

'If it is not charity which induces us to undertake a task which brings us into contact with the worst of our sex, what else can be our motive? And yet you represent us in the House of Commons as the most abandoned of human beings.'

(8)

There the matter might have rested but for the persistent efforts of Charles Newdegate, the Member of Parliament for Warwickshire, and but for the public interest in some instances of litigation concerning convents.

(9)

Mr. Newdegate's perseverance was rewarded in 1870 when the Commons agreed to set up a Select Committee on the Law Respecting Conventual and Monastic Institutions. A former Good Shepherd nun, Lady Gertrude Douglas, was moved to protest at length in the Times newspaper, and a number of leading roman catholics, including the Duke of Norfolk, organised a public meeting. Despite the furore, the Select Committee proceeded with its enquiry. To complicate matters for the nuns, the bishops were away in Rome attending the 1st Vatican Council. A committee of influential roman catholic lawyers and politicians agreed that it was necessary to co-operate with the enquiry in order to protect convent property and to pacify the public demand for information. The Select Committee was much impressed by the evidence submitted by the roman catholic lawyers, to Mr. Newdegate's considerable disgust. Although the committee's report stopped short of an actual recommendation to change the law, it did point clearly to the confused legal situation of the convents and their property.

(10)

(11)

(12)

(13)

(14)

The campaign for inspection was limited to the nuns themselves and their property. There was, as yet, no particular concern about the inmates of the institutions run by nuns. For nearly 20 years

the Good Shepherd nuns had accepted government inspection of their reformatory schools. The convict refuge had been subject to similar scrutiny since its inception in 1866. Although there had been initial difficulties, the sisters understood the necessity for the inspection of institutions partially subsidised by public funds. Indeed they had undertaken the reformatory school work within 3 years of the first inspection bill which had so upset them in 1853. Whatever may have been the motivation of Thomas Chambers and Charles Newdegate, and setting the property issue apart for the present, the sisters realised that to concede the inspection of their convents by the civil authorities would fundamentally weaken the practical and symbolic value of the enclosure. It has already been noted how strict enclosure was regarded as a basic safeguard to nuns, especially its function of providing a stable context for their own transformation. (15) The inspection of the reformatory girls or the convict women posed no such threat. Paradoxically, it served to enhance the standing of the sisters as a community providing important public utilities. It will be remembered how Napoleon only allowed the re-establishment of the refuges in France on precisely that understanding. (16) In his evidence to the Select Committee, the roman catholic solicitor, Mr. Harting, had specifically asserted that the main function of the religious orders was:

'to meet the wants of modern society and modern times, arising from the great increase of poverty, great increase of population, great increase of crime, and all those many things which have to be considered and provided for in a great community.'

(17)

The Victorians understood as well as any age, if not better, that good works depended on strong ideals. Historians of the period make much of this point. (18) Yet good works require good funds and therein lies the practical import of the charitable trusts question for

the Good Shepherd Sisters. It is an issue at once practical and ideological. Although in 1832 an Act of Parliament (19) had placed roman catholic charities on the same basis as those of protestant nonconformists, in 1835 it had been held in *West v Shuttleworth* (20) that certain (21) charitable purposes were illegal under an earlier statute of 1714.

Such purposes were held to be the application of charitable bequests to 'superstitious purposes', of which masses for the dead or provision for monastic communities would be examples. *West v Shuttleworth* became the leading case and the tenor of subsequent judgments gave grounds for the prudent assumption that bequests to convents might be held to fall within the category of superstitious uses. Indeed it was (22) quite clear from an Act of 1791 that any trust establishing a religious order was illegal in itself and could only be considered charitable if the objectives of the order fell within conventional charitable purposes, such as providing an orphanage. Furthermore the 1829 Emanicipation Act had declared monastic institutions illegal. (23) Neither the 1853 Charitable Trusts Act, which created the Charities Commission and provided for the registration of charities, nor the (24) 1860 Act which extended it to roman catholics, had repealed the earlier legislation.

Roman catholics had been reluctant to register their charities with the Commissioners as it seemed to imply state control. Manning, at this time Provost of Westminster, felt it incumbent to enquire of the Roman authorities:

'How can the bishops submit their Trusts to the Commission if they thereby recognise the *altum dominium* in the State - that is, to deny the Church?'

(25)

If leading ecclesiastics were writing in such terms, it is hardly surprising that the matter was perplexing to the sisters. In any

case, given the unrepealed legal disabilities, it is understandable that few roman catholics risked their trusts being found void by the Charity Commissioners. The difficulty did not arise with the actual institutions run by the Good Shepherd Sisters as these were clearly charitable within the ordinary usage of the term. As early as 1856 the property of the Good Shepherd reformatory school in Bristol, as distinct from the convent itself, had been vested in a separate charitable

(26)
trust. In 1862 Bishop William Clifford had advised the sisters that this would be a legal and appropriate course of action for the magdalen asylums as well. (27) But the pivot of Good Shepherd activity was the convent, and there seemed no way for the sisters to hold their property communally with safety other than to subsume it into the property of the institutions they provided. In this way there came about a paradoxical legal and symbolic inversion of the status relationships between sisters and penitents within the order.

Other devices like joint tenancy were difficult. The secret purpose of a joint tenancy was of no legal standing if one tenant reneged on her private understanding that she held her part of the property for the religious order. Even if honour held, nuns were not family relatives and succession duties would become payable on the death of any tenant. If the Charity Commissioners became aware of such an arrangement, they could put the property into trust with trustees appointed by the Lord Chancellor. The charitable object would be maintained but the sisters would have lost control. In the end the sisters put their convent properties in trust to some of the sisters as individuals without naming the Good Shepherd order. At the same time they made a private declaration of conscience to the bishop that the property belonged to the order. Thus the Good Shepherd ownership of convent property rested solely on the good will of a few sisters. It was not until 1877 that the sisters put matters on

a safe footing, after taking legal advice from Frederick Bagshawe QC. He was strongly of the opinion that they should declare a trust and enrol it with the Charity Commissioners. This would exempt the nuns from succession duty and place them in a definite and certain basis in the eyes of the law:

'The deed might likely be so framed so as not to disclose their smaller, or indeed any of their rules, and to preclude any interference with the nuns or their penitents, either by the civil or practically, if they so desired by the ecclesiastical authorities, and at the same time to give the Superiors of the Convent almost unlimited power in dealing with the trust property.'

(28)

Although practical matters concerning the control of property and finances were at stake, and the sisters were not insensitive to that, there was a more radical concern behind the issues. It was a concern to demonstrate and secure a definition of the convent as an autonomous religious institution totally distinct from the secular world. This issue arises again and again in the constant struggle to become exempt from rates and taxes.

Such then is the background: The roman catholic authorities had averted parliamentary attempts to inspect convents and their property holdings. Given the legally anomalous status of convents however, it was not something to be taken for granted. It is ironic that the marginality already noted as characteristic of transformative activity should be so perfectly reflected in the civic and legal marginality of roman catholic convents in nineteenth century England. It was a dilemma for the sisters. They were torn between the need for public recognition in this world and the need to establish themselves as primarily concerned with the other world. This dilemma, their experience of the parliamentary battle to impose inspection, and the search for a legal personality, must be borne in mind constantly when the matter

of factory inspection is recounted and analysed.

The magdalen asylum had not been subject to any form of public control or inspection since its establishment in 1841. This reflected the general public commitment of the Victorians to philanthropic work with fallen women. In any case, such control may well have been thought unnecessary for institutions which only accepted women whose desire for admission and reform was entirely voluntary, and who were free to leave the asylum at any time. In 1841 factory and labour legislation had been at an early stage of development and laundries did not become regulated until 1895. There are only two recorded instances of former inmates accusing the Good Shepherd Sisters of ill-treatment. On both occasions the nuns were entirely vindicated by the court. (29) The asylum was further removed from public control by its exemption from the Poor Rate and from Income Tax, although these exemptions seem to have been the subject of perennial negotiation. The magdalen asylum, the work par excellence of the sisters and the raison d'etre of their institutional existence within the Roman Catholic Church, was thus wholly free of public control.

The sisters had been familiar with government inspection ever since they undertook the management of reformatory schools at Bristol and Glasgow in the late 1850's. Although this had settled into an amicable working arrangement, it is notable that at the start there was considerable dissension between the Home Office and the roman catholic authorities as to the extent of the inspection. The Bishop of Clifton, Dr. Clifford, acting on behalf of the Good Shepherd Sisters at Bristol, put the issue very clearly to the Rev. Sydney Turner, the Inspector of Reformatory Schools:

'Suppose an Inspector is authorised to inspect Catholic children, and suppose a difference of opinion to arise between the Inspector and the Catholic Chaplain as to

'what belongs to religion and what to secular instruction the government would claim a right to settle such points through the Inspector or otherwise - and differences might perhaps be avoided through the moderation of individual inspectors, but Government would still claim the right then to interfere in religious questions, even if the Inspector refrained from using it. This is what Catholics object to'

(30)

The content of this objection is specific to the religious education of girls in roman catholic reformatory schools. The form, however, is recurrent in all the subsequent discussions on the differing forms of inspection to which the sisters became subject. It is a struggle over the authority to establish the boundaries between the sacred and the secular; a struggle made all the more complex by the very overlap of these two basic categories in the context of transformative activity.

The convict refuge, established in 1866, was subject to inspection by officials of the Directors of Convict Prisons as a condition of receipt of capitation grant from public funds. Although independently managed, it was liable to such control as was necessary to ensure its efficient administration as an integral part of the 'Intermediate System' then being developed by the prison authorities. The certified inebriate reformatory was in an identical position to the convict refuge, except that public control and inspection were exercised through the Home Office 'Inspector under the Inebriate Acts'. Neither in the reformatory schools, nor the convict refuge, nor the certified inebriate reformatory was inspection directed specifically or centrally to issues concerning the conditions of inmate labour. Such concern as there was turned on their part in the rehabilitative programme.

Laundries had been exempt from the 1878 Factories and Workshops
(31)
Acts, which had amended and consolidated all the previous
legislation. The laundry trade had been united in its opposition

(32)

to inclusion, mainly due to the irregularity of the hours worked.

The Chief Inspector of Factories later advised the Home Secretary that another reason for exclusion had been the prevalent opinion that women workers would be disadvantaged by any fixed limits on the hours

(33)

worked. After an abortive attempt in 1891, the power laundries

(34)

were included in the 1895 Factory Act. Convent laundries evaded

further efforts to include them in 1901 and 1904 and were finally

brought under the Act in 1907. The earlier attempts to include all

laundries had failed because the Irish Members of Parliament concerted

to defeat the amendments simply to avert the inspection of convent

(35)

laundries. One contemporary commenting on the failure of the 1891

amendment noted:

'.... the opposition feeling the weakness of their own arguments, suddenly appealed to the religious prejudices of a portion of the House with the result that they had a narrow majority of nine.'

(36)

The Chief Inspector had commented on the employment of women when the London Women's Trades Council asked to meet the Home Secretary to consider the appointment of a Lady Factory Inspector and the inclusion of laundries under the 1878 Act. The L.W.T.C. was concerned at the severity of laundry work, often done in conditions so objectionable that, contrary to the general trend for many occupations, men were taking jobs from women:

'a change which women cannot regard as seemly or beneficial'.

(37)

Eventually they got their lady inspector, Miss Mary Abraham. She came to play a part in the organisation of the laundresses, and not a little in the affairs of the Good Shepherd Sisters. A concern with the conditions of laundry work as a sweated trade was recurrent during

the last two decades of the 19th Century. It is not surprising that this concern should have reflected upon the activities of the charitable laundries.

Amid the mounting public and political pressures that led up to the enactment of the 1895 Factories and Workshops Act two issues predominated: Whether the Act should include the charitable laundries and whether it should include the hand laundries. The latter, small laundries in which no more than two persons were employed, had been severely criticised for sweating practices. In 1890 a select committee of the House of Lords had reported on the sweating system, and late in the same year the Home Secretary, Henry Matthews, had initiated an enquiry into the factory inspectorate. The Chief Inspector had come to so perfunctory a conclusion that he had been ordered to begin again. His anti-semitic chauvinism can hardly have provided a basis for policy:

'.... London Jews are fairly well in order, but foreign Jews do not change their most filthy habits; their domestic workshops are the dirtiest of all, in many cases living and working in one room, that generally at night in small tenements, the excess of gas burning is injurious to health.'

(38)

The truth of the matter was that the government could no longer simply disregard the issue. Additionally, the hand laundries had long been considered seedbeds of drunkenness by social reformers and temperance advocates. It was mainly against the hand laundries that the Women's Trades Councils had directed their opposition.

The two separate legislative issues concerning charitable laundries and hand laundries were not infrequently confused; largely because both were seen as sweated industries. Already the government was aware of the results of official enquiries into sweating practices in French convents, most of which were engaged in contract sewing

for large manufacturers. In Britain, sweating practices would not be subject to direct legislative intervention until the 1909 Trade Boards Act. However, by the late 1890's the Chief Inspector of Factories was making explicit reference to the sweated conditions in charitable (39) laundries. There can be no doubt that it was a proper matter of public concern, but caution is necessary in interpreting the evidence. Allegations of sweating against the convent laundries were a convenient means of protecting a primarily commercial concern to limit serious competition. Mary Abraham's later enquiries into the Good Shepherd laundries certainly exonerate the nuns from imposing excessive hours (40) of work, and this was the gravamen of the case. A complex array of interests were at work in the campaign to bring the charitable laundries under the Factory Acts.

A major protagonist in the struggle was the National Laundry Association, although according to Charles Booth it was not well supported (41) by the trade. The N.L.A. very mainly represented the proprietors of the large commercial power laundries. Their view was clear and cogently argued: The charitable laundries should be included because their exemption from certain rates and taxes and their use of unpaid labour put them in a position of advantageous and unfair competition. The proprietor of a steam laundry in West Norwood commented:

'There are a number of charitable institutions, who are at present carrying on Laundry work as a trade, at such prices that there is no possibility for a public laundry to compete. They pay little or no wages and are besides supported by voluntary contributions. One of these institutions was in 1893 doing over £5,000 work at a loss.'

(42)

The writer recognised, that as such work represented a source of revenue in the overall institutional finances rather than a clearly demarcated commercial profit or loss, it was difficult to regulate.

On the other issue the N.L.A. argued that not to include hand laundries under the Act was to exclude that very sector of the industry which most required a public check on sweating practices. To add grist to their case on charitable laundries they accused them of using sweated labour. At a meeting with M.P.'s, Mr. John Burn a member who had espoused their cause alleged:

'.... there are many of these benevolent, philanthropic institutions who under the guise of charity fallen women are taken off the streets and there sweated and persecuted and bullied under the most loathsome conditions in the style exposed by Mr. Labouchere in the Zirenberg case.'

(43)

The Zirenberg case, with its lurid details of sexual exploitation and brutality, was a gift to the pro-inclusion lobby. It fuelled the case for control while at the same time bringing the religious phalanthropies into disrepute. (44) Zirenberg had brought a libel charge against the proprietor of the secularist journal 'Truth' for publishing a Charity Organisation Society reported on the extreme sweating of workers practised at the laundry in his unlicensed home for inebriate (45) women. The house was advertised as a religious charity and on that basis received donations and subscriptions. The case against (46) Labouchere was dismissed. It was an extreme and public illustration of the general principle central to the pro-inclusionist case and put to good effect in that cause.

The other main thrust for the inclusion of laundries had come from the London Women's Trades Council who had organised a mass demonstration in Hyde Park in support of their deputation to the Home Secretary. They were to be joined by the Women's Trade Union League who had decided to abandon an earlier laissez faire policy and to campaign for the regulation of laundry hours. Altogether the pro-inclusionists constituted a strange amalgam of large steam laundry proprietors, certain secularist

and anti-roman catholic pressure groups, some of the less skilled steam laundry operatives, and the women's trade union movement. From the point of view of the sisters it must have represented a spectre of commercialism against charity, the secular against the sacred, and a strident feminism in conflict with the traditional roles of women.

Ranged against inclusion were most cottage laundry workers and employers, who felt all their business would go to the steam laundries, the more skilled steam laundry operatives, some of the proprietors of the larger laundries employing home workers, the Society for Promoting the Employment of Women and the Reformatory and Refuge Union. In 1893 the Women's Industrial Defence Committee of the S.P.E.W. had published a report on the conditions of women's work in laundries. (47) It concluded that any legislative intervention would discriminate against the majority of laundry workers who were married women unable to work fixed shifts and whose circumstances fitted well with the intrinsic irregularity of laundry work. Although they were against inclusion, they agreed with the contention of the women trade unionists that the introduction of machinery tended to favour the employment of men. This was not the experience of the Good Shepherd Sisters who, at most, employed a competent maintenance man for the steam machinery. The W.I.D. Committee argued that the legislation was partially motivated by social reformers seeking to inculcate temperance and morality; yet they omitted charitable laundries from their enquiry:

'Such institutions, being carried on for the improvement of the inmates and not for purposes of gain, afford no basis for comparison, nor furnish any data with regard to the exigencies of the trade.'

(48)

Thus they unwittingly recognised the claim of the charitable laundries

to be a wholly different enterprise. The women who worked for hand laundries held a number of meetings to protest against inclusion, often at the instigation of their employers and with the encouragement of the W.I.D. Committee.

By far the major opposition came from the Reformatory and Refuge Union which addressed itself solely to promoting the exclusion of the charitable laundries. Within that brief it was more concerned to avert the imposition of universal hours of work than to prevent inspection, the latter being a possibility that alarmed roman catholics more than protestants. It was clear that the overwhelming body of informed opinion, both in the trade and outside, were for bringing the power laundries within the Factory Act. Consequently much of the public debate was focussed on laundries conducted by philanthropic institutions. The case advanced by the R.R.U. turned on three major issues. Firstly, there was the charge of unfair commercial advantage. They rebutted this by asserting that refuges often charged higher laundry prices as they had higher overhead expenditure such as the maintenance of the inmates. Secondly, the institutions they represented could not be tied to fixed hours of laundry work since they provided education in the reformatories; and in the refuges the women were organised into classes for instruction as well as undertaking the domestic chores of the house. Consequently, there could be no hard and fast line controlling the laundry time-table. Finally, reformatory schools and convict refuges were already subject to inspection by other government departments, although the R.R.U. were willing to accept some form of inspection for voluntary homes such as the magdalen asylums. (49) The Good Shepherd Sisters at Cork added a separate submission, to which the English sisters were privy, stressing the seclusion necessary for the Magdalen Sisters and the penitents, and the flexibility of

hours necessary to meet all the religious activities of the convent. They considered that inspection would be positively harmful to the central task of reclaiming fallen women. In any case, the total weekly hours already worked were within the proposed limits. (50)

The hard-headed Mary Abraham, now Chief Lady Inspector of Factories, was set to investigate the matter. Her scrutiny was very thorough. She was disposed to agree with the contention that refuge laundries were not conducted under the same conditions as the commercial laundries, but pointed out that they had the major advantage of free labour. As the inmates were clothed and fed by voluntary subscriptions there was no expenditure on wages. In point of fact this source of revenue was of insignificant proportion in Good Shepherd finances. On the question of hours she concluded:

'The hours worked are similar to a leniently conducted factory.'

(51)

So far as inspection was concerned, she conceded that the reformatory and prison inspectorate could be used for factory purposes where appropriate, and with reference to the Zirenberg case she commented:

'(The Reformatory and Refuge Union is) of the opinion that in view of recent disclosures in the management of a certain house, inspection is desirable but they consider special legislation is necessary. I do not consider the case has been established.'

(52)

The Chief Inspector of Factories underwrote the report while pointing out that the real comparison was with prison laundries, where the Act would not apply since it would be subversive to discipline. Clearly the Good Shepherd Sisters were faced with another dilemma. They would reject the comparison with prisons and its assumption of compulsion, yet the R.R.U., of which all their superiors were active members,

asserted that the limitation on hours which would become a statutory right of inmates was inconsistent with the internal control of the inmates.

Mary Abraham investigated further the specific claims of the Good Shepherd convents:

'The main objection seemed to be the 'nature of inclusion', in one case the Superioress adding that she believed it would weaken her power over the women employed, who are recruited from the fallen class. It was felt that evidence of their subjection to rules in the form of an Advertisement exhibited in the Laundry, would make it more difficult for the nuns to enforce the discipline of the convent.'

(53)

Perceptively, she had noticed that even convent laundries employed a few ordinary workers and so it could not be argued that they were purely philanthropic. In addition, she reported, the laundries were separate from the convents and inspection would not interfere with the religious aspect. But in this view Mary Abraham appears to have showed herself ignorant or dismissive of the sisters' own ideological understanding of the role of the laundry in the work of conversion.

In the meantime the sisters were in private correspondence and negotiations with Henry Matthews, the Home Secretary in the last Conservative Government and a roman catholic. He urged them to provide him with as much factual information as possible. He explained pressure group tactics at a private meeting with the Provincial Superior. He undertook to present the convent petitions for exemption to the House of Commons. In the meantime he suggested:

'If you can bring influence to bear on Members of Parliament, by all means do so - the Irish members ought to be open to influence in this direction.'

(55)

In which suggestion Cardinal Vaughan had privately concurred.

(56)

About the same time the Belfast Weekly News printed a letter which provoked a back bench member to put down a question on the government's intention on the exemption of convent laundries. The writer of the letter was not far wrong:

'The Factory and Workshop Bill has flustered the Roman Catholic bishops the priests are beating the drum ecclesiastic. Cardinal Vaughan has been lobbying all the Nationalist members.'

(57)

The government was flustered too. Sir Kenelm Digby, the Permanent Under-Secretary and another roman catholic, advised the Home Secretary that the question was too difficult to give any pledge. The battle lines were drawn and they seemed to be primarily religious. A junior member of the government commented to the National Laundry Association:

'In regard to the inclusion of charitable institutions the religious difficulty comes in and the Roman Catholic authorities are against any such idea and the same sentiment prevails among the Church of England people. I am not in a position to say that this opposition on the part of the Roman Catholic and English establishments will be met by the Home Secretary, but at any rate I think it will not be met to such an extent as to exclude these institutions altogether.'

(58)

Thus the roman catholic lobby, powerfully combined with the protestant and philanthropic interests in the R.R.U., succeeded in securing the exemption of charitable laundries from the 1895 Act. However, events were happening in France which would make this a relatively short-lived privilege.

The difficulties that the Good Shepherd Sisters had begun to experience in France from about 1893 are complex in their ramifications but clearly related to the further development of the inclusionist struggle in England. The difficulties started when the Superior General and the Bishop of Nancy, Monsignor Turinaz, could not agree over

matters concerning the internal organisation and development of the Good Shepherd Convent at Nancy. It had all begun with a difference of opinion over the convent chaplain, but finally devolved onto two issues. The bishop was claiming power to administer the convent property and asserting that the sisters were obliged in justice and charity to pay fixed rates of wages to the inmates. The Good Shepherd Congregation submitted the issues to the Roman authorities who found against Bishop Turinaz in April 1884. The bishop exercised his right to have the case re-heard by a plenary session of the Sacred Congregation concerned with the affairs of religious orders. Time was given for fresh submissions by both parties. In March 1896 the Sacred Congregation upheld the earlier decision, much to Bishop Turinaz's chagrin.

In his submission Bishop Turinaz had made strong allegations about the conditions of work in the Good Shepherd convent at Nancy and about the Good Shepherd Congregation in general. He based his case on the failure of the sisters to pay wages to the inmates, whether reformatory girls or penitents, and to prepare them for an independent life outside the institution, either with employable skills or by granting departure allowances:

'These religious violate all the rules of morality It is necessary to admit that they are able to give themselves over to the essential purpose of exploiting the young women by subjecting them to work which outstrips their strength in order to gain as much money as possible; that they betray them to the risks and perhaps the shame of prostitution by sending them away without means and without attending to providing them with respectable situations I point out again that these crimes are certainly committed in all the houses of the Good Shepherd.'

(59)

And in a circular letter to the bishops of France he added:

'.... they make the young women, and the people whom they pretend to receive out of charity, work beyond

'the hours prescribed by the civil law, they break all the most elementary laws not only of charity, but also of justice, the instruction of Leo XIII on salary, and they give no help to the young women and persons who leave the house after having worked there for 5, 10, 20 and 30 years.'

(60)

These extracts are typical of the tenor of his accusations. Basically the Good Shepherd defence challenged Bishop Turinaz' claims on the two main issues of administrative jurisdiction and wages, rebutted in detail his charges about 'crimes', and protested about his immoderate language. Although the sisters' answer to the detailed charges is persuasive, it is significant that the Roman authorities only addressed themselves to the two main issues. Rome did not reply to the bishop's ex parte submission so far as the allegations were concerned but referred (61) them to the Bishop of Angers for further detailed enquiry. The results of this enquiry were either satisfactory to Rome or less, but either way silence was to prevail and there the matter was expected to end.

There exists a Vatican journal *Analecta Romana* which occasionally publishes decisions of the Holy See, especially if these relate to controversial points. Such was the question of the jurisdiction of a diocesan bishop over the temporal affairs of a convent in his diocese. Equally controversial was the question of wages in charitable institutions, the more particularly as a test of Leo XIII's recent teaching on wages and labour conditions. The decisions in the Good Shepherd case were published in 1896 by a French journalist, M. Bonnefon, later described in the French Parliament as a man:

'.... who is always happy to do somebody a bad turn, no matter who, so long as he attracts the public's attention, and he attacks not without skilfulness, sometimes the Right and sometimes the Left.'

(62)

Monsieur Bonnefon was, no doubt, a good investigative journalist.

In any event he published a full account of the 'Affaire Nancy' in the Journal on 22nd September 1899. Bishop Turinaz could no longer keep silent and in the following month he wrote a letter to the bitterly pro-roman catholic paper La Croix repeating, and embroidering (so the nuns (63) thought) the substance of his allegations. Inevitably the case was seized upon by the anti-clerical parties then powerfully influential in France. It was mainly the Turinaz allegations that were repeated in the press, particularly in two series of articles in Aurore and Lanterne.

In 1879, when the Republicans had gained control of both houses in the French Parliament and also taken the Presidency, the long-standing battle between Church and State was joined in earnest. New laws to secularise education were introduced, and by the end of the 1880's policy had definitely moved towards the creation of a secular state. Tough fiscal laws were imposed on the religious congregations which, in any case, were now only allowed to exist by government (64) authority. Moves to more moderate policies, welcomed by both Republican and Liberal roman catholic deputies, came to nothing due to the threat of a monarchist coup d'etat in 1889. French roman catholic opinion in general, and many bishops, still clung to the hope of a restoration of the monarchy, despite the Vatican policy of 'Ralliement' directed at persuading them to support the Third Republic. Indeed, in 1892 Pope Leo XIII had firmly to remind French roman catholics of their civic duty to be loyal to the State.

The Dreyfus Affair pre-occupied the 1890's and ruined any possibility of uniting roman catholics, monarchists, and conservative republicans against more radical republican policies. In 1894 Dreyfus, a jewish captain in the French army, had been convicted by court martial of selling military secrets to the Germans. He was sentenced to life imprisonment and deported to the French penal colony at Devil's Island.

Subsequently, further evidence came to light which disproved his complicity, but the military authorities refused to re-open the case. After considerable public and political debate, in which figures such as Clemenceau and Emile Durkheim championed Dreyfus, a second court-martial was held in 1899. Once more Dreyfus was convicted, but with a rider that he had acted under extenuating circumstances. He was not pardoned until 1906 when he was vindicated by a civil court. The case led to a political re-alignment, and a coalition government of radicals and socialists was formed under the moderate leadership of Waldeck-Rousseau. Furthermore, the Dreyfus case increasingly led to the identification of roman catholicism with a virulent anti-semitism of which La Croix was a foremost exponent. In fact it was so delighted by Dreyfus' re-conviction that it announced:

'Justice has been done, Dreyfus has been condemned.
As Frenchmen we rejoice over it. As Catholics we
praise God for it.'

(65)

La Croix had become so intemperate that Leo XIII informed its directors that he deplored 'the spirit and tone of their newspaper'. The affair provided to the government a convenient means for a renewed and more radical programme of anti-clerical measures. By the closing years of the nineteenth century the situation had become acute and the press on both sides was active in keeping up the tension. The roman catholic journals tended to see everything in terms of a conspiracy between the jews, protestants, and freemasons to de-christianise France. While the liberal and republican press could scarcely see anything other in the Church than the subjection of young minds to superstition, (66) papal domination in temporal affairs, and exploitative gain.

Such was the volatile political situation into which the Nancy Affair burst in 1899. It soon became a rallying point for both sides

in 'La Lutte Religieuse'. In the same year Waldeck-Rousseau had been appointed Prime Minister. He lost no time in prosecuting vigorously a policy directed at regulating the status of religious congregations, so that the State could control their influence. In 1903, when the Nancy Affair was reaching its most public crisis, he was succeeded by Emile Combes, an ex-seminarian turned politician. He immediately set about applying Waldeck-Rousseau's laws with a systematic malevolence and with that single-minded energy frequently characteristic of apostates

(67)

from any cause. The Good Shepherd Sisters had already been deprived of 'éducation correctionnelle' and had become subject to heavy taxes on both capital and revenue. They were, however, one of the few congregations allowed to continue with the refuge and preservation work which had been legally recognised as a public utility under the original

(68)

decree of Napoleon.

Given such a situation it is hardly surprising that Bonnefon's article was a sensation. It was quickly taken up by the newspaper Aurore, the leading mass circulation paper supporting the government.

(69)

It commissioned a series of articles from an ex-priest called Guinaudeau. Here was an account of convent exploitation culled direct from an official Vatican publication; a case in which Rome had failed to uphold the allegation of sweating practices made by a local French bishop. It was a scoop by any reckoning. The sensation was fuelled by Turinaz'

(70)

letter in La Croix, whose willingness to publish it can only be attributed to a distaste for Leo XIII's policies on social justice and accommodation to the Republic. When this was quickly followed by the publication of an open letter from Mgr. Rumeau, the Bishop of Angers, to the Superior General of the Good Shepherd Sisters rebutting each of Turinaz' allegations, the public debate was well and truly

(71)

launched.

In no time the matter was raised in the Chamber of Deputies by

(72)
 M. Fournière, the Minister of the Interior. He called for a more stringent and extensive inspection of convent charitable institutions; for an increase in the provision of lay charitable institutions; and for a public enquiry into the Nancy allegations. To add weight to his demands he cited the case of Marie Lecoanet who had spent 16 years at the Nancy convent prior to leaving there in 1889. She had made three attempts to introduce litigation against the Nancy Good Shepherd Sisters between 1896 and 1899 each of which had been refused by the judicial authorities. (73)
 M. Fournière informed the Chamber that he was so incensed by this that he had complained to the Minister of Justice. At this point the debate was entered by M. Lemire, a clerical deputy, who spoke vigorously in defence of the Good Shepherd Sisters. This only evoked a government supporter, M. Laferre, to insist on a more stringent application of the Napoleonic decree of 1810 in order to subject the convents to inspection by civic officials. In his view the legal power already existed. M. Waldeck-Rousseau then announced that the government had already instigated enquiries as a result of Bishop Turinaz' letter to La Croix. There had been three investigations. The Inspector of Charities of the Department of Meuthe-et-Moselle reported on 24th October 1899:

'We have acquired the conviction that it would be impossible to obtain elsewhere for our undisciplined and light-mannered girls a more favourable union of mental and moral conditions than they enjoy at the Good Shepherd.'

(74)

The divisional Inspector of Labour also gave a favourable report, (75)
 commenting that the law was now strictly observed. The Nancy Police (76)
 were able to affirm that everything had been satisfactory since 1896.

Waldeck-Rousseau, who more than anyone had been responsible for the introduction of anti-clerical legislation, had to refuse a public

enquiry. He gentled his embarrassment by leaving the detailed allegations to police investigation. He then went on to express his view that the case indicated the necessity of the introduction of legislation to require the regular inspection of private institutions. They should not be authorised by the State unless they paid discharge gratuities to all the inmates.

These were measures easier said than done, as is not uncommon with political prescriptions. A leading French criminologist of the day, an expert in penal affairs, calculated on the basis of official government statistics that the discharge savings of inmates in charitable establishments was six times that accumulated by the inmates of State institutions. M. Henri Joly asserted on the same evidence that punishment was about half as frequent and that the State provision cost (77) twice as much. Inspection there might be, but no amount of rhetorical posturing could evade the public need of the charitable institutions or the immense public expenditure that would be required for their replacement. On a number of occasions Joly returned to this issue in the journal La Reforme Sociale; and so the debate went on in a veritable kaleidoscope of reason and invective.

In March 1900 the legal conduct of Marie Lecoanet's case was taken over by the liberal League of Human Rights, and it was at this juncture that the English Good Shepherd Sisters became more directly involved. The Contemporary Review published two articles in March and April under the common title 'Monastic Order Up To Date'. The author wrote under the pseudonym E. Saint Genix. The first article, subtitled 'Roman Catholic Fetishism' was an out and out detraction of popular pious practices in France, especially that of prayer to the saints, maintaining that:

'.... the Roman Catholic Church has degenerated

'in France and become a bloodsucking vampire of a kind probably unmatched in history. It keeps tens of thousands in intellectual thralldom and material poverty, that its own ministers may wax fat.'

(78)

Thus wetting the appetite for the April instalment entitled 'The Sweating of Orphan Girls'. This was hostile to the Good Shepherd Congregation and used as its main source the partisan articles of M. Guinaudeau in L'Aurore and Bishop Turinaz' letter to La Croix. The article was immoderate and dramatic in tone, thundering on to the conclusion:

'And this is the Rome which asks to be heard with respect even by Protestants and Agnostics on the labour question.'

(79)

A clear reference to Leo XIII's encyclical Rerum Novarum on the relationship of capital and labour.

(80)

Although there was no specific reference to any English houses of the Good Shepherd Congregation, the implications were clear enough. There had been mention of the Nancy Affair in some of the English newspapers at the end of 1899. The Liverpool Evening Express had reported without comment the result of the police investigation that had been initiated by Waldeck-Rousseau. Earlier, the roman catholic journal the Weekly Register in a somewhat intemperate article had supported the Bishop of Nancy on the principle that the penitents should be paid a wage commensurate with their labour. So far as that was concerned Cardinal Vaughan sent word by his private secretary:

(81)

(82)

'.... it must not trouble you in the least and you must take no notice of it.'

(83)

As early as 1896 the English sisters had been aware of the problems

at Nancy through their contact with Pere Francois Ory, the priest in charge of the canonisation process of their foundress Mother Pelletier. (84) By January 1900 he could contain his discretion no longer and confided in the English Provincial Superior:

'The Bishop of Nancy is unbalanced, he has revolted against the Holy See. He will not do the evil he wishes to do. Pray for him.'

(85)

Soon after the publication of the Contemporary Review article a number of priests and nuns from other orders, not to mention some of the Good Shepherd sisters themselves, pressed for a public refutation. This time Cardinal Vaughan approved (86) and at the request of the English Provincial Superior more first-hand information was made available from Angers. (87)

The sisters commissioned Father Sydney Smith, the editor of the Jesuit intellectual journal The Month. An influential Dominican, Fr. Bertram Wilberforce, was also involved. Fr. Smith's article was published in June 1900. (88) He had relied heavily on the Good Shepherd 'Defense' of 1895, having checked the sources in the Analecta, and made use of the official Blue Book reports of government inspections of Good Shepherd reformatory schools at Bristol and Glasgow. It was a convincing reply, beautifully written and moderately expressed. He treated the allegations of Turinaz and Fourniere as completely distinct. It is significant that Smith also stressed the point that Rome had only made a decision on the two questions submitted by the Good Shepherd Sisters. In his view Rome's silence since requesting a detailed investigation by the Bishop of Angers permitted 'the simple hypothesis' that the Nancy sisters were innocent of the charges. (89)

In addition he argued that Bishop Rumeau's open letter of November 1899 could be taken as an indication of what he may already have

submitted to Rome after his inquiry. Be that as it may, later evidence indicates the annoyance of the Roman authorities when the Good Shepherd Sisters in France broke silence in 1905 and published their definitive reply to the alleged cruelties. (90)

While preparing his article Smith had elicited from the sisters details about working hours, laundry profits, and inmate costs; and so had Fr. Wilberforce. Both were aware that there was a body of roman catholic opinion in England which favoured the payment of wages to the penitents. For both men the fact that Rome had made no public refutation of the detailed charges made by the Bishop of Nancy was clearly a matter of considerable private concern whatever they might write for the public. Both were very supportive of the Good Shepherd Sisters in England but, at the least, doubtful about the events in France. Writing to one of the nuns, Wilberforce had this to say: (91)

'.... but knowing all your houses as I do I thought I might write to show that none of these accusations apply to them, at the same time not implying that they may be true in France: but only that I cannot speak of France from personal knowledge It must be the devil that tries to paint a house of the Good Shepherd as worse than Dotheboy's Hall!'

(92)

In the event Wilberforce left the article to Smith who devoted only a small part to the wages question, and then only expressed the principles behind the Good Shepherd view of the matter. This stands in stark contrast to his private opinion that:

'To be effective this defence must have details.'

(93)

The archive material includes a number of draft financial computations in which the bursar of the time sought to arrive at a presentation

of the accounts which would indicate that inmate maintenance costs exceeded laundry profits on a per capita basis. (95) The Contemporary Review article did not require any specific rebuttal so far as the English Good Shepherd Sisters were concerned, but it is clear from the private correspondence that the wages issue was a contentious question in both roman catholic and protestant circles. There is no evidence to suggest that at this stage the English sisters were prepared to grapple with the problem of wages to penitents, or even whether they understood it to be an urgent issue of social justice. One might have expected a greater awareness from the nuns given the contentions of the National Laundry Association a few years previously. (96) The Provincial Superior tended to view the controversy as no more than a particularly nasty chapter in the traditional antagonisms between roman catholic and protestant in England. The Finchley annalist saw the episode as one of calumnious and persecutory attacks on the Congregation by freemasons, atheists and ex-priests. A catharsis of the pen she brought to a close with the wish:

'May we not trust that this time of persecution will be like all that's patiently borne, the seed of great good to our beloved Order?'

(97)

Smith's article had evoked little significant response and the sisters were glad enough to sink into the silence. The Lecoanet case had gone to appeal and it may have been that the English press was biding its time against the result. The peace was only an interlude for in March 1901 Mrs. Virginia Crawford published in the Economic Journal a reasoned plea for the payment of wages to the inmates of charitable institutions. (98) Mrs. Crawford was one of the younger generation of roman catholics who had been much inspired by Manning's concern for social justice and by his work in seeking to give practical

(99)

effect to the social and economic teachings of Pope Leo XIII. She was an active member of the Catholic Social Union and a founding member of its far more organised successor, the Catholic Social Guild. Among other things she was a Poor Law Guardian at St. Marylebone. It was the same Mrs. Crawford whose confessions of adultery had brought about the downfall of the radical Liberal M.P. Sir Charles Dilke. Although she had since become a roman catholic, her past may have discredited her arguments in the eyes of the nuns.

(100)

Mrs. Crawford reviewed the present practices of the charitable institutions, noting the strict supervision, the laundry work, the provision of shelter, food, and clothing, and the possibility of a new job and outfit for the better cases on discharge:

'I have never heard of a single accusation of personal unkindness brought against any Sister of any Catholic house, but I have frequent complaints of the harshness of the life, of the poorness of the food, and of the entire absence of any monetary remuneration.'

(102)

She concluded that the present methods were not well adapted to the original aims and that the welfare of the individual inmates had become subordinated to the general welfare of the institutions. In short, the stereotyped regime of the refuge had become one in which:

'.... the managers depend too much on time, discipline, routine and tradition.'

(103)

Whatever theological rationale might be advanced, she considered that the old idea of keeping the penitents in the refuge as long as possible brought with it all the dangers of institutionalisation. The system was also self-reinforcing, for a long stay secured a high level of workmanship. This was often secured by too much specialisation. This, in turn, lowered employment possibilities outside and created

a further danger of keeping good workers in the refuge longer than necessary. The specialisation issue had been raised by Turinaz and countered by Bishop Rumeau as an inevitable consequence of the tendency to large scale enterprise. Rumeau deplored monopoly and centralisation but:

'.... one will see in all factories, in lay ones often more than in those living under religious influence, workers invariably applied all the time to the same identical task.'

(104)

Given that the inmates were very largely destitute members of the working class, the proper method of conversion and recovery, Mrs. Crawford argued, would be to equip them to become self-supporting wage earners as quickly as possible:

'Our penitentiaries need humanising, and the payment of wages is the first essential step in that direction.'

(105)

Virginia Crawford had noted that large scale institutional laundry work was a very paying business and simply to provide the inmates with maintenance was no fair return for their work. In her view wages should be a first charge on the profits. After deduction of maintenance costs the inmates should be given a small spending allowance, with the major balance being saved against their discharge. She based her calculations on the current weekly rates of pay to laundry workers in the commercial sphere and on an estimate of institutional maintenance costs. After making the case for wages on grounds of social justice as well as on those of an effective and realistic rehabilitation, she went on to assert that laundry work was, in any event, unsuitable for refuges. Current trends suggested that the demand for domestic laundry maids had dropped and employment in the commercial laundries would bring the former penitents into contact with past undesirable

associates; it being well known that laundry work ranked very low and that lack of character was no bar to employment. At the very least, she thought, the laundry work should be supplemented by tailoring and cooking.

Later in the year a private correspondent commented that many influential roman catholics supported Mrs. Crawford's view. It would not cost much to introduce a pay system based on that in use in prisons. That writer wished to make no personal criticism of the sisters. Even so:

'.... something wants (or did want) altering to bring the Order into harmony with the Spirit of the Age.'

(106)

Mrs. Crawford had widely circulated her article in pamphlet form. As a result the superiors of the Good Shepherd houses in Britain were having to deal with many queries from local supporters of their work; often informed roman catholics who did not understand the reluctance to pay some form of wage or allowance. Roman catholic awareness of social questions was beginning to develop as a result of the stands taken by Cardinal Manning. Within recent memory Bishop Brown of Newport had called for financial help for the striking steelworkers. Bishop Bagshawe of Nottingham had issued two pastoral letters in favour of collectivism and had even called for the formation of an English roman catholic parliamentary party. Bagshawe had gone so far as to assert that state intervention was necessary as workers:

'.... were taken advantage of by capitalists and employers to deprive them unjustly of the greater part of the first fruit of their toil.'

(109)

It has to be said that these were normally the opinions of only a

small minority of educated roman catholics who tended to favour Liberal Party policies. Even so, they could pester and alarm Good Shepherd superiors with pertinent questions and persuasive arguments. They were also not to be alienated for they were often persons of standing and influence in local communities.

No doubt the Provincial Superior took all that into consideration, but she remained intransigent. She issued a circular letter to the superiors setting out the economic grounds on which wages could not be paid. There was no real attempt at any sustained ideological justification, nor any response to Mrs. Crawford's general argument. It referred solely to what one might call the 'arithmetical' section of Mrs. Crawford's paper, and that was only one page out of sixteen. The circular provided a detailed financial argument against wages by showing that the real cost of inmate maintenance was higher than the article estimated, and that the workforce actually achieved far lower per capita average earnings than workers outside. The latter figure would be lower still if account were taken of the notional earnings of the sisters who worked in the laundry. (110) The tactic was simply to discredit the whole of Mrs. Crawford's argument by pointing to the impracticability of her proposals. Thus the sisters laid themselves open to the charge of what she had called 'pious opportunism'. The argument would be rejoined later, but in the meantime other issues had come to the fore once again.

In the middle of 1901 there was a renewed parliamentary attempt to include the charitable laundries under the Factory Act. Cardinal Vaughan called the Provincial Superior to discussions with leading roman catholic politicians and lawyers. (111) They need not have worried, for yet again the Irish members defeated the amendment and averted the threat of official inspection. The Nancy scandal was currently

dormant in England, but it was coming increasingly difficult for charitable laundries to allay the suspicion that there were things to hide. Sensitive to this aspect of public opinion the Reformatory and Refuge Union held a conference to set up an allied body 'The Inspection of Homes Association'. A number of member institutions were already in favour of official inspection but it was felt that a voluntary system of inspection by officials appointed by the new association would at least show good will to the government and the public and avert the charge that there was something to hide. (112) There is no evidence that the Good Shepherd Sisters participated in the scheme despite their many years of active involvement in the R.R.U. It is not improbable that the spectre of a visit from a lay protestant man or woman with institutional experience was more to be feared than the intrusion of Her Majesty's Inspectors of Factories.

At about the same time, as the sisters would have known, Marie Lecoanet had been granted an interlocutory order by the Nancy Court. The effect of this was to set up judicial enquiries to take depositions from the witnesses of both sides. These eventually took place at Nancy and Paris in the early part of 1902. The case was then reheard at Nancy when the court found in Marie Lecoanet's favour on 28th February 1903 and awarded her damages of 10,000 francs with interest. (113) Emile Combes lost no time in advising a Presidential Decree to suppress (114) the Nancy Good Shepherd convent and this was issued on 11th March. Interestingly enough, Bishop Turinaz protested at this decision in a letter to the Est Republicain at Nancy. That paper took him to task for such a contradiction. The editor claimed that there were so many Jews in Lorraine that the clerical party could not use the Dreyfus affair. Consequently the bishop had used the Good Shepherd affair to create socialist and atheist agitation, being aware that

that his opinions were of considerable moral and political influence
(115)

in the region. In an article published at the end of the year

Sydney Smith also pointed out how Turinaz had defied the government
(116)

over the suppression of religious orders. George Ryder was to do the

same in his plea to the sisters on wages. It was quite clear that

Turinaz' allegations presented a serious difficulty to thinking English

roman catholics. He was certainly no creature of the French government.

Rome had never pronounced on his allegations about sweating practices.

As Sydney Smith was well aware, Rome knew when silence was best.

The English press had already broken silence in February with
lurid reports of the evidence submitted on Marie Lecoanet's behalf.

The Daily News carried a front page story under the title 'Convent
(117)

Horrors' and this was quickly followed by the Daily Chronicle
(118)

with 'The White Slave Trade: Charge of Cruelty against Nuns'. The

Daily News commented on the silence of the religious press, unaware

that the Provincial Superior had failed to persuade the Tablet and
(119)

the Catholic Times to carry a more restrained and balanced account.

Now that the French judges had delivered their verdict against the

Good Shepherd English roman catholics were probably reluctant to become

too closely associated.

In April the National Review published an article on the Nancy

Affair written by its editor Leo Maxse to make good, as he put it,

the fact that no British journal had yet published a full account.

Maxse systematically summarised the evidence submitted by Marie Lecoanet

and her witnesses. He anticipated charges that the case had been

exploited for political purposes and that the Republican judges had

been biased. These he countered by pointing to the origins of the

case in Bishop Turinaz' allegations and retold the history of the
(120)

case up to the final hearing at Nancy. To the ordinary informed

Englishman of the day, whether roman catholic or protestant, a judicial

decision reached after due and lengthy process, especially if ultimately unappealed by the respondent, was not something to be dismissed lightly, even in the law courts of France. That the article failed to expatiate on the respondent's evidence was of no consequence, given the decision of the judges. That the writer of the article had suggested the case might have relevance to the English experience was no more than fair comment from a journal that had a point of view.

In no time at all the Jesuits at Farm Street were digging into Maxse's background. After all, whatever its shortcomings, argument ad hominem did have its uses in the war of words. Fr. Thurston, whose knowledge of the byways of liberal catholicism might have rendered him sympathetic, reported him not to be a well-balanced person, an obstinate and prejudiced man, whose sister had married into the anti-Catholic family of Lord Salisbury. Even so:

'.... there were redeeming features about his fierce hostility to Catholicism.'

(121)

Precisely what they were Fr. Thurston did not reveal. The Duchess of Newcastle, a long time friend of the Good Shepherd Sisters wrote directly to Maxse with an invitation to visit the convent at Finchley. (122)

Maxse declined and referred her to the forthcoming sequel to be written by Sir Godfrey Lushington:

'.... probably as eminent an authority on the subject as is to be found.'

(123)

It was this which really perturbed the roman catholics. Maxse had refrained from mentioning that he was his brother-in-law. Lushington (124) had been Permanent Under-Secretary at the Home Office from 1885 to 1895, and before that Home Office Legal Adviser since 1869. His

official testimonial, written by Asquith when Liberal Home Secretary, had described him as a zealous high-minded officer who brought to the task:

'.... the resources of a subtle and many-sided mind, and of a wide and generous culture with rare qualities of patience, kindness, firm temper, and good comradeship.'

(125)

The problem was that Lushington seemed to agree and he was no friend of roman catholics.

In the few weeks prior to Lushington's article appearing there was much activity behind the scenes to try and reduce its effect. The sisters only knew the title: 'The Good Shepherd at Nancy: The English Moral'. They were aware that Maxse had told the Duchess of Newcastle that it contained no accusations against British Good Shepherd houses. It is instructive therefore to examine closely the precise concerns and points of contention that were being expressed in private.

The Maxse article had been brought to the attention of the Good Shepherd Sisters by George Ryder a leading roman catholic lawyer in London. One of his sisters was a Good Shepherd nun at Newcastle. He knew that the National Review articles would have considerable impact. He was concerned to ensure that the sisters did not underestimate the quality of the journal or its readership:

'What we are concerned about is the judgement of the well-disposed, just-minded Catholic and Protestant men and women of the world who admire charity and self-sacrifice, but who are aware that the ill-regulated pursuit of those virtues may involve a violation of justice.'

(126)

He stressed the idea of justice as necessary to true charity and as a basis for a good relationship between the nuns and those who worked under them in the laundry. There could be no justice at all if the

nuns were dependent on the earnings of the inmates, even in part, nor while they failed to credit them with a fair wage. He viewed the laundry as very much a business. Far from shunning inspection,
 (127)
 the nuns should court it.

On the wages question, his sister in Liverpool replied:

'You say good work demands good wages - true, but does work always demand money. There are different ways of making a return for services.'

(128)

Sister Ryder then went on to develop the theme that the penitents entered not for wages but to be treated for a sickness of soul. For this they needed the kind of mother's care that the sisters provided. To pay wages to a penitent in a hospital was unthinkable. In any case it would be totally contrary to the mother-child relationship that existed between nun and penitent. If the penitents felt that they had not received the spiritual help for which they had entered then they could always complain. In addition it was highly likely that the type of woman in the refuge would spend an accumulation of wages on drink or bad company.

On inspection she was slightly more accommodating, if it were to be carried out in the right spirit; but there were still serious problems. The penitents came from all social classes and confidentiality was all important. It might be severely compromised by pompous or inquisitive inspectors. She would not object to a discreet inspector who stuck strictly to the requirements of the Factory Act. So far as the Nancy revelations were concerned:

'We may be old-fashioned in our ways and these will change in time but we are true Mothers to our poor children and are no more capable of keeping them for gain than we are of cutting their throats.'

(129)

When Sister Ryder passed copies of this correspondence with her brother to the Provincial Superior, she pointed out the inadequacy of the dormitory provision for the penitents and the general failure to be sufficiently generous to them when they left the refuge:

'If it comes out in public that we make them keep their basins under the bed and wash on the floor people will cry shame on us it would not be asked of the poorest maid of all work Our old fashioned French customs which were encouraged by the poverty of early beginnings must give way before long either by our free act or by force of public opinion.'

(130)

George Ryder later came back with a powerful rebuttal. He conceded the philosophy behind the Good Shepherd system and acknowledged that wages were a problem in that context. He understood the charity argument, as a good business would normally be unable to employ many of the kind of women in the refuge. That being said, he was more concerned about what a judge might decide between the nuns and a disaffected penitent. In his view the Good Shepherd system was essentially unjust as there was no freedom to contract. To equate wages with spiritual benefits was little short of simony. The condition of the penitents on entry was so necessitous that virtually no other alternative presented itself short of the workhouse. Once inside the refuge they were subject to undue influence from the sisters, who also controlled departure:

'The system on which the institution is conducted withholds the power of leaving respectably and with a fair chance of success from the penitents, except at the good pleasure of the nuns.'

(131)

The sisters so controlled the power of movement through the system that it was fundamentally unjust. In no sense could the relationship between the sisters and the penitents be held to be contractually free even when spiritual rehabilitation and material maintenance were

substituted for wages. It was a sustained critique expressed in the form of a legal argument. He submitted this to a friend of his, Edward Wilberforce, also a successful roman catholic lawyer, to see whether he could come up with a convincing defence.

Wilberforce argued in his imaginary defence of the Good Shepherd Sisters that the kind of women who entered the refuge were incapable of sustaining a contract, as anyone with refuge experience would know. The turnover of inmates was such that it could hardly be maintained that the sisters forced or induced them to stay, merely for the sake of their labour. When it came to control of departure, instant dismissal only happened rarely on the basis of some serious fault harmful to the other women. Any woman who exercised her undoubted right to leave against the prudent advice of the sisters had only herself to blame. Whether they left with work skills or not was irrelevant because that was not in itself a sign of moral cure:

'All I have said comes to this - the Homes of the Good Shepherd are hospitals for moral diseases.'

(132)

It was Ryder who had brought out the notion of contract implicit in the wages issue and Wilberforce had based his defence on the idea of contractual incapacity. There the matter rested for the time being.

When Lushington's article appeared in May, it began by rehearsing, yet again, the general facts of the Leconet case as they had been presented by her lawyer. Lushington noted that whatever charges might have been made against particular sisters, the real offender was the whole order. Personnel were interchangeable and the rules of the order do not die. It was the perpetuation of the system that was the real danger. It was quite clear from the Nancy evidence that the Good Shepherd convent was a factory worked for gain. It was a factory that exhibited all the evils that were struck at by English

factory legislation: no wages, no contract, residence on the premises, no inspection, no protection, all under proprietors with absolute authority.

But surely, Lushington went on, it was a contradiction for a convent to be a factory. A convent cultivated an interest in the next world and disregarded the affairs of this world. The nuns avoided the contradiction by what Lushington called the 'convent theory', viz. the penitents are saved from this world. This theory is then used to justify the enclosure, renaming of inmates, no talk of the past, control of communication, no property, no liberty, and no holidays. It was nothing other than a penal and terrorist discipline.

The English moral in all this was straightforward. Although one might not find the excesses made manifest at Nancy, the Good Shepherd sisters in England belonged to the same international religious congregation and could be expected, therefore, to use the same system. Lushington was aware that there were other voluntary institutions outside the Factory Act, but what made the convents so different was the enclosure. This seclusion was not justified; the sisters as well as the penitents were subject to the momentum and tradition of the system. Consequently, vigilant observation and publicity were essential. He pointed out that as well as being exempt from the Factory Act the Good Shepherd Sisters had held back from the Home Office invitation to accept voluntary inspection. He appealed for an official enquiry which, he hoped, would recommend the regulation and inspection of convent laundries. Ultimately he thought it would be as well to subject the convents themselves to inspection, not merely the laundry aspect, and in this he echoed the struggles of 1853 and 1870. It was an interesting analysis and well presented. Lushington had stressed inspection rather than wages. The ways he dealt with the issues was

so complementary to the questions raised by Ryder that one wonders
(133)
whether the latter man had seen the article before publication.

Sister Ryder considered there was enough truth in Lushington's
(134)
article to give the order serious cause for concern. Nevertheless:

'It may all pass as the nasty article in the Contemporary
Review last year did without doing us any harm - but of
course it may make mischief if fussy bodies like Mrs.
Crawford and so take the matter up.'

(135)

Lushington was aware that about the time of the Nancy decision
the Home Office had issued an invitation to the charitable laundries
to accept voluntary inspection. Cardinal Vaughan had held a meeting
with the bishops and prominent roman catholic politicians. He had
also consulted with the Chief Inspector of Factories and Sir Kenelm
Digby, Lushington's successor at the Home Office, a former judge and
a roman catholic to boot. The bishops then agreed unanimously that
it would be expedient for the sisters to accept the inspection invitation.
So far as the inspectorate was concerned Vaughan informed the Provincial
Superior:

'They are well disposed and will inspect only what you
choose to show them and will send their observations
and recommendations in writing. I advise you to apply
for all your laundries and to say you have no desire for
a lady inspector.'

(136)

Other roman catholics were also pressing the nuns to accept the Home
Office invitation before parliament insisted.
(137)

The Provincial Superior went so far as to draft a letter of accept-
(138)
ance but this was never sent. The delay was partially due to
the resistance of the roman catholic inspector of religious instruction
(139)
in reformatory schools, Rev. W. Richards He acknowledged that
Lushington's article was awkward and regrettable and argued that any

eventual inspection would be conducted more sympathetically by the Reformatory School Inspectors than the Factory Inspectors. To request inspection now would be to strengthen the hands of those who wished to impose Factory Act supervision. Richards certainly succeeded in delaying matters, he obviously had an axe to grind, and he obviously misunderstood the radical difference between a reformatory school and a voluntary magdalen asylum. However, it was a good enough reason to convince Cardinal Vaughan. This reason for justifying a delay was seized on by the sisters. Although they were beginning to bow to the inevitable, too rapid a consent to inspection would have been deeply embarrassing.

Within two weeks of Lushington's article the Provincial Superior had sent out a circular to all the superiors:

'There is such a storm going on outside about us, we fear it can only end in inspection and so in order to be ready for any emergency we want you to let us know what you think of the following points and what you can do to have everything in order that if a Government Inspector were to be sent there would be nothing he could find fault with.'

(140)

The points in question were the quality of the dormitory provision, the monotony and adequacy of the diet, and the practice of working the penitents two hours before breakfast. This internal investigation was not conducted until July when it was agreed to invite inspection for the laundries only. That was all that the Home Office had envisaged, but the sisters seemed to have thought that a wider inspection was intended. This may have been because the French factory inspectorate had wider powers, but more probably because Lushington had raised the old bogey of convent inspection. The investigation revealed quite decisively what Sr. Ryder had already asserted. The dormitories and the diet needed substantial improvement. On the laundry side the

hours worked were well within the existing regulations and the long period of work before breakfast could be adjusted. If the penitents worked up to the limit of the regulation, it should be possible to improve the dormitories and refectories. At the same time it would permit the possibility of a small allowance to the penitents, to be saved against departure. The writer of the report was quick to point (141) out that this would quite likely be reduced by fines.

At about the same time another document was produced setting out the case against wages. Unlike the circular that dealt with Mrs. Crawford's views, the reasons now advanced were ideological rather than economic. Firstly, wages would alter the whole character of the institute which was a 'voluntary penitentiary or reformatory'. It was not a business, but relied on quasi-filial relationships. Secondly, there was no injustice in exacting labour without wages. All that they gained by their transformation from unemployable and disordered persons to spiritually rehabilitated women with employable skills far outweighed what they had given in their work. Finally, experience showed the Good Shepherd system to be superior, for even non-roman catholic prison officials had remarked that it was the best (142) means of reformation of character.

Later in the year Eugene Prevost, Marie Lecoanet's counsel, had (143) published a book on the Nancy case. It was a very full account of the plaintiff's case but it only gave the most cursory report of the Good Shepherd evidence. A copy annotated by the Angers sisters and the transcripts of their evidence and pleadings were made available to Sydney Smith. A perusal of this material was enough to convince him (144) that the Nancy trial had been a grave miscarriage of justice. By December he had put together an article for the Month. It was essentially a precis of a paper published by Henri Joly in the Reforme Sociale of

(145)
 the previous June. It did little more than put the essentials of each side of the case on public record in England. It was a gesture that satisfied Good Shepherd honour more than anything else, and Smith was careful to footnote his conclusion with the proviso:

'We most particularly protest that we are giving M. Joly's opinion.'

(146)

Although the English Good Shepherd Sisters were still reluctant to concede inspection, it is evident that the controversy caused them to make considerable improvements in the condition of the penitents. These were substantially carried through between 1903 and 1906. Ironically, the factory inspections were never to extend to the residential facilities, nor to matters of food, clothing and wages. An irony compounded by the fact that when the 1907 Factory Act eventually burst upon them they had to make considerable modifications to the laundries.

In February 1906 the Finchley annalist noted with alarm that the Liberals had come to power:

'A revolutionary spirit seems to be rising rapidly, much as in other countries and fervent prayer is needed to avert the evils threatened to our Holy Religion.'

(147)

It would have alarmed her even further had she known that practically the whole team of journalists from the Daily News had entered the new parliament as Liberal M.P.'s. (148)
 By 1907 the Factory and Workshop Act had been amended to include convent laundries. (149)
 The new Act permitted the managers of charitable laundries to submit for the approval of the Home Secretary and the House of Commons a scheme for hours and holidays, provided these were no less favourable than the provisions of the 1901 Act. It exempted the managers from the duty to display

statutory notices in the laundry premises, and allowed managers, on due notice to the Chief Inspector, to forbid an inspector to interview inmates privately.

These were considerable concessions. The Act, however, laid down stringent conditions for the arrangement of the laundry premises. Where mechanical power was used fans would be required to remove steam from the washroom and to regulate the temperature in the ironing room. The stoves for heating the irons were to be housed separately from the ironing room. Floors were to be properly drained. The Finchley annalist felt that these regulations could only give satisfaction, yet:

'.... it was most unpleasant to be under the new regulations and be obliged to receive visits from the appointed Inspector.'

(150)

The annalist of the Glasgow convent noted that the modifications bringing their laundry to the standards required by the Act seemed to give the penitents a renewed zeal for their work. The Bristol convent was pleasantly surprised by the friendly attitude of the lady inspector. While the Hammersmith annalist noted after the first visit of their inspector:

'With obvious satisfaction he heard from our Mother that she preferred him to a lady. He was rather elderly and informed our Mother that he suffered from gout, and altogether was inclined to be friendly. The visit to the Laundry took him over an hour, and he expressed himself very pleased and satisfied.'

(153)

The sister in charge of the laundry at Ashford wrote to Finchley:

'Our Factory Inspector has been today and was very polite and nice - he only took a short look round, and seemed quite satisfied; he came around with a printed formula of points to be enquired about,

'though he said at the same time we were not obliged to answer his questions - there was nothing however that there was any difficulty in answering so we made none, thinking that was the simplest and best policy - and I hope we were right.'

(154)

The annalist at Finchley need not have worried herself for there, too, the inspection went off very well, although the inspector did
(155)
recommend better fans for ventilation.

By the end of 1908 all the Good Shepherd establishments were subject to official inspection of some kind or other. The sisters had long since accepted inspection for their reformatory school and convict refuge. During the course of the Nancy Affair they found no difficulty in accepting government inspection of their inebriate reformatory. Now at last the nine magdalen asylums had come under inspection. The inspecting of laundries was nothing as extensive as the inspection of the other institutions, with their purview of accommodation, diet, and food, as well as work. Why they would accept the latter inspections so readily while resisting the other for so long is one of the questions to be considered in the final chapter.

The inspection issue was now resolved but the wages question would not go away. The sisters' fight over inspection and the wages controversy occurred during a period when there was much public debate over 'fair wages'. The London County Council and the House of Commons had both adopted Fair Wages Resolutions. These enabled them to set a public example and to exercise a degree of enforcement by incorporating a fair wage clause in contracts awarded to private enterprises. A weakness in this procedure was that enforcement depended on workers' complaints and this proved to be ineffective. The Trade Unions frequently proposed inspection by government officials as the best
(156)
method of enforcement. Although the idea was not adopted, there

ensured a public discussion linking wages with inspection.

This occurred during the period when the sisters were beset by the Nancy Affair and the pressures to concede inspection and wages. Nothing further came of it at the time, but the weakness of the enforcement procedures eventually led to the enactment of the 1909 Trade Boards Act to supervise conditions and wages. In 1910 four Trade Boards were set up to supervise the worst sweated industries; tailoring, paperbox making, lace finishing, and chain making. (157) By 1913 there were 13 Boards but the war delayed the Board for the laundry trade (158) and this was not established until 1919.

Early in 1914 a parliamentary attempt to include the charitable laundries in the proposed Laundry Trade Board had failed. Shortly after, a member of the London County Council moved that no female labour engaged in laundry work for the L.C.C. should be paid less than 5 pence per hour. It was supported by a roman catholic member. During the debate frequent reference was made to the conditions in convent laundries. Although the precise terms of the motion were defeated, the Council agreed to press the government to amend the 1900 Act to include charitable undertakings. In the meantime it altered its own regulations to secure better wages in laundries tendering for Council work. (159) These moves were a much greater threat to the Good Shepherd Sisters than the previous problems with inspection and wages. The Good Shepherd laundries depended substantially on contract work; in Glasgow and Liverpool from the shipping companies, in London from hotels, and in all the laundries there was work done under contract from other institutions. To bring the convent laundries under the supervision of a Trade Board did not simply mean securing a fair wage, it meant paying wages for the first time. During the 1901 crisis the sisters had presented an economic argument against the payment of wages, whereas in 1903 they had relied primarily on ideological

grounds to resist this innovation.

On this occasion a letter was drafted for circulation to roman catholic M.P.'s, although it was never sent due to the onset of the First World War. This letter rehearsed all the old arguments about the external unemployability of the work force; the necessity to train them made them a charge rather than a resource; voluntary entrance for reformation rather than for gainful employment; and the destruction of the spirit of the work by a wage relationship:

'A 'Trade Spirit' would sink the home to the level of a factory. It would make the work of the Sisters who devote their lives to the raising of their fellow creatures an impossibility and this because of f.s.d. - Evidently the persons who bring forward this suggestion and who wish to legislate for the well-being of the poor, lose sight of the higher motive of Christian charity, which must be the basis of any work of reformation that is to be lasting, successful and bear fruit.'

(160)

The economic argument was not engaged. Convent laundries were never included under the Trade Boards Act and right up to the closure of the last laundries in the early 1970's wages were never paid to the inmates.

The question of contract re-appeared again with the 1906 Workmen's Compensation Act. The Provincial Superior had raised with her legal advisers whether the penitents were workpeople within the meaning of the Act. In their view the central issue was whether a contract of service existed between the nuns and the women. There was a kind of exchange of food and shelter for laundry work, but taken together with the power of instant dismissal it did not seem to amount to a legal contract. The validity of the exchange argument would, moreover, depend on whether the sisters made a profit out of the work. In that, their charitable status was not to the point. Here were difficult

issues: profit, contract, and the apparent irrelevance of the keystone concept of charity. The Provincial Superior wisely decided not to open that particular Pandora's Box but to wait quietly against the day when a test case might come to the courts:

'Meantime we trust that Our Lord will preserve us from accidents to the dear children. It would be no joke insuring them in our houses.'

(161)

Without contract there could be no breach of contract, and without duties imposed by law there could be no tort. This was a practical policy, given the sisters' history of reaction against any public legislation which seemed to affect them. There was also an inner consistency. Compensation was essentially a device to mitigate employers' liability. The doctrine of filial relationship central to their argument against wages and inspection implied the absolute liability of a mother for her children.

Although the publicly contentious issue of control had related to inspection and wages, there had always been a quiet but persistent struggle over local rates and central government taxation. It has already been recounted that as early as 1847 the Hammersmith sisters had successfully gone to law over local taxation. Obviously the nuns as much as anyone else, were influenced by the notion that taxes were a burden to be avoided. Yet money tied them into the secular world and mediated relationships they would rather abjure. This is a theme that will be developed later. Although the sisters were obviously aware of the economic advantages in avoiding taxation and sought to obtain them, the actual issues on which exemption was fought were more fundamental than any economic gain.

The story has been told how the Hammersmith sisters struggled from 1847 to 1856 before they reached a settlement over the Poor Rate.

All they ever achieved in that matter was a reduced assessment. That was the case with all their convents until the Poor Rate was abolished. It was a continual irritation to them that a charitable institution catering very largely for poor people should be subject to this particular liability; an irritation not only because they felt themselves to be a voluntary charity unfairly contributing to state charity, but also because it seemed to threaten their own charitable integrity.

(165)

The Finchley lawyer expressed it as an anomaly that had to be paid.

When the matter came up for annual re-negotiation at the Manchester convent in 1893, the same arguments were used to try and prevent a visit by the Poor Rate Assessment Committee as were used against factory inspection a little later.

(166)

In 1877 The Good Shepherd Sisters obtained from the Inland Revenue, for all their houses, an exemption from Income Tax and Inhabited House

(167)

Duty. It had been successfully argued that their institutions were hospitals within the meaning of the relevant legislation.

(168)

Moreover, two Elizabethan statutes expressly included houses for the reception of fallen women in the term 'hospital'. The 1877 ruling held good for some years but there were increasing attempts to bring the convents into fuller taxation.

(169)

The Finance Act 1885 sought to impose an additional tax on properties vested in bodies, whether corporate or incorporate, to compensate for the loss of revenue occasioned by their freedom from such liabilities as succession duty. The Act caused a furore among roman catholics, sensitive as they were to the drift of church-state relations in France. Bishop Clifford negotiated with the government on behalf of all roman catholic institutions. Meanwhile the convents were ordered to make no tax returns and to forward all correspondence to their local bishops. The bishops need not have worried, for one Good Shepherd sister noted on the back of her episcopal directive:

'The late Mothers put all such papers in the fire
- but if the authorities get troublesome it would
be better to send the papers to the Bishop.'

(170)

These negotiations dragged on until 1893 when the government quietly dropped the original proposals. The Good Shepherd sisters went on protected by the 1877 exemption. However, they were privately advised by their lawyers that they certainly came within the spirit of the Act, if not its strict letter. The 1877 correspondence made it quite clear that the Inland Revenue thought so at the time. The Inland Revenue were beginning to notice that most Good Shepherd properties
(171)
were not vested in charitable trustees.

The matter came up again with the 1910 Finance Act, which was designed by Lloyd George as an important implement of social reform. Basically it was directed at land taxation and was radical in its
(172)
proposals. This raised considerable problems for the sisters with their large holdings of land, often serving more as a 'buffer zone' than as a recreational or agricultural utility. It raised questions about vacant use and development and these, in their turn, led to issues central to the claim to be a 'voluntary penitentiary' rather than a business. Legal opinion was that their best way of getting out of this new tax was to register trust deeds with the Charity Commissioners. Given the problems encountered in the 1860's and the 1870's it is surprising that this had not yet been done. It was still undone in 1915 when their lawyer advised them that it was the wisest course, pointing out:

'Since the passing of the Finance Act 1910 all catholic lawyers are puzzled to find the best course for convents and ecclesiastical properties'.

(173)

With a dark nuance about the French experience, he tried to force

action by referring to the problem of governments seizing the property of religious orders.

More and more tax liabilities of charitable institutions were devolving onto the nature of the revenue by which they were supported. The Inland Revenue and the courts were looking more closely at the relative proportions of income derived from the laundry and endowments or gifts. It had been held in 1888 that an institution wholly self-supporting from inmate labour was not exempt as a hospital, even if charitable funds had been used to set it up. To be exempt it must
(174)
be wholly or partly dependent on charitable endowments or subscriptions. In short it was always necessary to establish that the laundry income was insufficient and that benefactions were a crucial element in their solvency. The sisters' dowries could not count, as canon law required them to be invested until death. Consequently in civil law a dowry remained the property of a nun even though she had given over its administration and relinquished any personal claim on the interest. The key element for the institution was to arrive at the end of the financial year without net profits. The relation between this and the sisters' arguments on inspection and wages are manifest in both legal and economic terms.

The events recounted in this chapter clearly reveal the sharp contradiction of the discourses surrounding the nature of the magdalen asylum. Although the overt struggle was over the working conditions of the inmates, and the control of property and finance, the latent struggle concerned the autonomy of the magdalen asylum as a quasi-monastic institution engaged in transforming a particular class of women. The nuns were caught in a dilemma. On the one side, the marginality of their transformative activity was reflected in a civic and legal marginality from which they sought to escape, while on the other

they insisted on preserving a boundary between secular life and the religious concerns of the magdalen asylum. Consequently every action of their opponents was interpreted in terms which had a primarily religious reference to their transformative task with the penitents. Apart from Sister Ryder's concern with the general living conditions of the women, nowhere does the evidence suggest that the nuns directly addressed themselves to the sweated labour issue. In so far as Mary Abraham had exonerated them, there had been no obvious need to do so.

The basic issue for the nuns was control, and that perceived as a necessary condition for their particular mode of transformation. It is ironic that they rebutted the attempt at inclusion under the Factory Acts by insisting on the character of the magdalen asylum as a home. Thus asserting, unintentionally, a degree of similarity to the cottage industries which had been the main source of public concern with sweated labour. The nuns may have conceded on inspection, but they remained adamant on the payment of wages. They well understood that to give way on that would have struck a devastating blow at the nature of the relationship between them and the penitents. These issues are taken up again and reworked in theoretical terms in the remaining chapters.