

TR/01/87

January 1987

Polygonal Patches of
High Order Continuity.

by

John A. Gregory and Jörg M. Hahn.

(120
QA
1
E78

z1623909

Polygonal Patches of High Order Continuity

By

John A. Gregory and Jörg M. Hahn.

Department of Mathematics and Statistics

Brunel University

Uxbridge UB8 3PH, England

This work was supported by the Science and Engineering
Research Council grant GR/D/77148.

Polygonal Patches of High Order Continuity

by John A. Gregory and Jörg M. Hahn

Abstract

A polygonal patch is defined to fill an n -sided hole within a rectangular C^k patch framework. First a reparameterization of the surface around the hole is constructed, that is defined outside a regular polygon. The polygonal patch is an interpolant, defined inside the polygon, that matches this parameterization up to order k along the boundary. Some modifications and handles to control the shape of the patch are described.

Key words

Polygonal Patches

Geometric Continuity

1• Introduction

The parametric representation of surfaces in CAGD (Computer Aided Geometric Design) is usually based on an assembly of patches with rectangular domains of definition. However, arbitrary surface topologies cannot be described by a regular rectangular patch framework. Either an arbitrary number of rectangular patches meeting at a vertex has to be allowed or a polygonal patch has to be filled in.

There have been several attempts to construct polygonal patches but these can only achieve C^1 continuous joins with their rectangular neighbours. For example, [Charrot and Gregory '84] describe a pentagonal patch defined by a convex combination of parametric surfaces. As pointed out in [Gregory and Hahn '86], this method cannot be immediately generalized to higher order continuity.

In this paper we consider polygonal patches with an arbitrary order of continuity. We exhibit an n -sided patch which can be used to fill in a hole within a rectangular C^k patch framework and which is such that the composition is a C^k continuous surface.

The continuity considerations cannot be treated within the given parameterizations, since the patches cannot be considered as being defined in a common parameter plane. The appropriate framework in which to examine continuity is the setting of geometric continuity ($G C^k$), cf. [Gregory and Hahn '86]. In our case, however, the C^k continuity of the basic patch will be guaranteed by giving an explicit C^k reparameterization of the surface around the hole. Only in the discussion of modifications to the basic patch will we need the more sophisticated techniques of geometric continuity.

The paper is organised as follows: Section 2 states the assumptions on the rectangular patch framework and introduces the notation for the polygonal domain on which the patch will be defined. Sections 3-6 contain the main part of the construction. In these sections we construct a C^k parameterization of the surface around the hole whose domain of definition is a strip around the polygon. This parameterization is extended into the polygon by interpolation. The final composition of the polygonal patch interpolant is given in Section 7 and in Section 8 we consider some examples and adaptations of this basic patch.

2. The polygonal patch problem

Assume that $f_j, j=0, \dots, n-1$, form a rectangular C^k patch framework around an n -sided hole. We suppose $n \geq 5$, but most of the paper also applies to the case $n = 3$. To make the exposition more concrete, suppose that each patch f_j is such that $f_j : \delta_0 \rightarrow \mathbb{R}^3$, where $\delta_0 := [0,1] \times [0,2]$ and where the segment $(0,s), 0 \leq s \leq 1$ is mapped to the j -th boundary segment of the hole, see Figure 1 (In practice f_j will usually be composed of two, or more, basic patches, for example Bernstein/Bezier or Hermite patches defined on $[0,1] \times [0,2]$ and $[0,1] \times [0,2]$.)

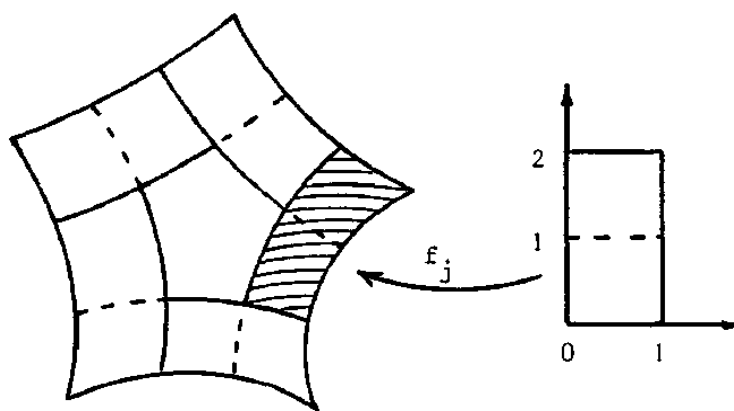

Figure 1

That the patches form a C^k patch framework means that for two adjacent patches f_j and f_{j+1} (indices mod n), the composed map

$$(2.1) \quad (u, v) \begin{cases} f_j(u, v) & \text{for } (u, v) \in [0,1] \times [0,2] \\ f_{j+1}(v-1, -u) & \text{for } (u, v) \in [-2,0] \times [1,2] \end{cases}$$

is C^k continuous, cf. Figure 2. Since we will apply Boolean sum interpolation techniques, we require in addition that this composed map is $C^{k,k}$ continuous, i.e. that the partial derivatives

$$(2.2) \quad \partial_{i_1, i_2} := \frac{\partial^{i_1+i_2}}{\partial u^{i_1} \partial v^{i_2}}$$

of the composed map exist for $i_1, i_2 \leq k$, are continuous and are independent of the order of differentiation.

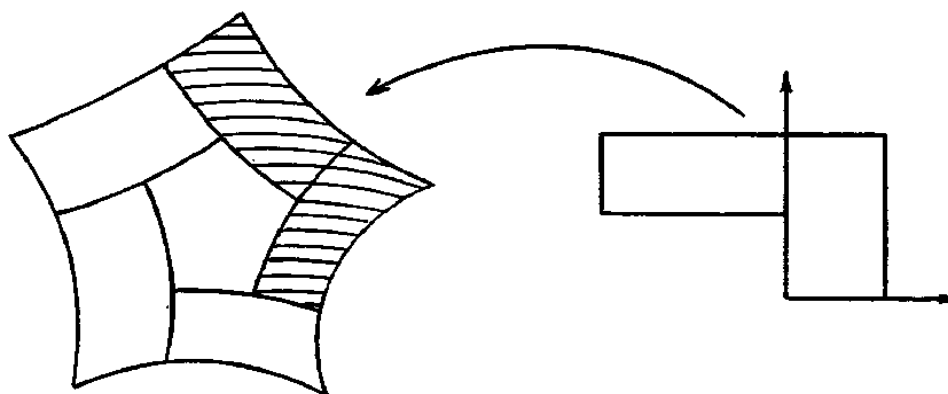

Figure 2

To be precise, our construction only requires that each patch f_j is $C^{k,k}$ continuous, defined on the right hand side of the segment $(0,s)$, $0 \leq s \leq 1$, and that

$$(2.3) \quad \partial_{i_1, i_2} f_j(0,1) = (-1)^{i_1} \partial_{i_2, i_1} f_{j+1}(0,0), \text{ for } i_1, i_2 \leq k .$$

This latter condition reflects the $C^{k,k}$ continuity of the composed map at the corner $(0,1)$.

The hole will be filled in with a patch P defined on a regular polygon and we adopt the following notation:

Let Ω be a closed, regular, n -sided polygon in \mathbb{R}^2 with centre 0 and sides of unit length. Its vertices are v_j , $j=0, \dots, n-1$, and its edges are E_j , parameterized by

$$(2.4) \quad E_j(s) = v_j + s(v_{j+1} - v_j)$$

Let Δ be a closed, symmetric strip around Ω . The strip is composed of closed tiles Δ_j , where Δ_j is the part of Δ which lies outside the edge E_j and on the same side of E_{j-1} as Ω , see Figure 3.

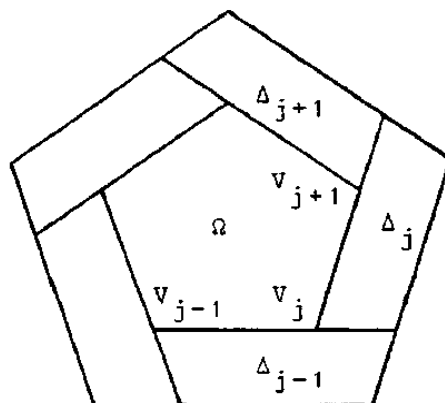

Figure 3

In expressions involving V_j , E_j , Δ_j , f_j , it will be useful to have the index j running over all the integers. Thus, in such cases the integers will be interpreted mod n , for example,

$$(2.5) \quad f_{j+n} := f_j.$$

Finally, the Euclidean scalar product in \mathbb{R}^2 is denoted by $\langle \cdot, \cdot \rangle$, i.e.

$$(2.6) \quad \langle (x_1, x_2), (y_1, y_2) \rangle := x_1 y_1 + x_2 y_2$$

3. Reparameterization of the boundary data

Our first goal is to reparameterize the surface around the hole to get a C^k parameterization F , defined on the strip Δ around the polygon Ω . (In practice only the restriction of F and its derivatives on the boundary of Ω will be needed).

The continuity conditions for the rectangular patches surrounding the hole mean that the domains of two adjacent patches f_j and f_{j+1} can be put together by rigid motions τ_j and τ_{j+1} in the parameter space \mathbb{R}^2 , such that the map

$$(3.1) \quad f_{j,j+1}(x) := \begin{cases} f_j \circ \tau_j^{-1}(x), & x \in \delta_j := \tau_j(\delta_0) \\ f_{j+1} \circ \tau_{j+1}^{-1}(x), & x \in \delta_{j+1} := \tau_{j+1}(\delta_0) \end{cases}$$

is C^k continuous on the composed domain $\delta_j \cup \delta_{j+1}$, cf. (2.1). The transformations

τ_j will not be required explicitly but, with τ_0 the identity map and $\delta_0 = [0,1] \times [0,2]$ the transformation τ_j is a rotation of $j\pi/2$ about the point $\left(-\frac{1}{2}, \frac{1}{2}\right)$. The domains can thus be rotated and pasted together but δ_4 will then overlap δ_0 . (In general $\delta_{j+4} = \delta_j$ and $v_{j+4} = v_j$, where v_j is the "vertex" $v_j = \tau_j(v_0)$ with $v_0 = (0,0)$.) Hence it is not possible to extend the parameterization to the union of the domains $\delta = \bigcup_{i=0}^{n-1} \delta_i$ in \mathbb{R}^2 , see Figure 4.

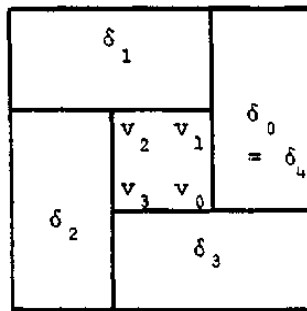

Figure 4

However, the parameterization can be extended if the domains δ_j are all considered as being different (think of a paper model, see Figure 5) and furthermore this procedure can be continued ad infinitum.

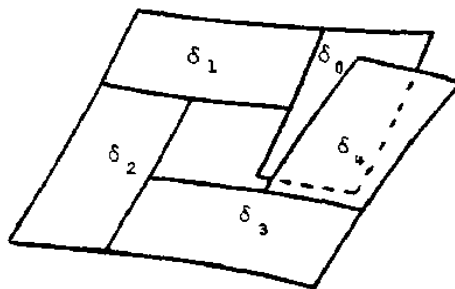

Figure 5

The mathematical object thus constructed is the "universal covering" of the exterior strip δ around the square. The universal covering will be denoted by $\tilde{\delta}$ and $\tilde{\tau}_j, j \in \mathbb{Z}$, denotes the displacement into $\tilde{\delta}$ that corresponds to the rigid motion τ_j in the parameter space \mathbb{R}^2 . Points, maps, etc., living in the universal covering will be marked by a tilde.

The universal covering may be viewed as an infinite spiral staircase, $\tilde{\delta} = \bigcup_{j \in \mathbb{Z}} \tilde{\delta}_j$ see Figure 6. Its stairs are the (rectangular) domains $\tilde{\delta}_j = \tilde{\tau}_j(\delta_0)$, $j \in \mathbb{Z}$, which are all different, where $\tilde{\delta}_j$ and $\tilde{\delta}_{j+1}$ are glued together smoothly. More precisely, $\tilde{\delta}$ is a smooth manifold together with a projection

$$\tilde{\delta} \rightarrow \delta$$

which maps the point $\tilde{\tau}_j(x) \in \tilde{\delta}$ ($x \in \delta_0$) to $\tau_j(x) \in \delta$, and whose restriction

$$\tilde{\delta}_j \cup \tilde{\delta}_{j+1} \rightarrow \delta_j \cup \delta_{j+1}$$

is a diffeomorphism. This projection maps the vertices \tilde{v}_j to v_j . Further details of covering theory may be found in any book on topology, e.g. [Singer and Thorpe '67] but no further knowledge of the theory will be needed here.

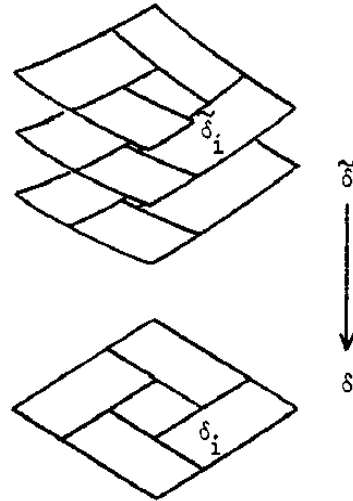

Figure 6

We now proceed as follows, cf. Figure 7:

The parameterization $\tilde{f} : \tilde{\delta} \rightarrow \mathbb{R}^3$, given by

$$(3.2) \quad \tilde{f}(\tilde{x}) : f_j \circ \tilde{\tau}_j^{-1}(\tilde{x}) \quad \text{for } \tilde{x} \in \tilde{\delta}_j,$$

is well defined on the universal covering of the square and C^k continuous, since on $\tilde{\delta}_j \cup \tilde{\delta}_{j+1}$

$$(3.3) \quad \tilde{f}(\tilde{x}) = f_{j,j+1}(x),$$

where $x \in \delta_j \cup \delta_{j+1}$ is the image of \tilde{x} under the projection $\tilde{\delta} \rightarrow \delta$.

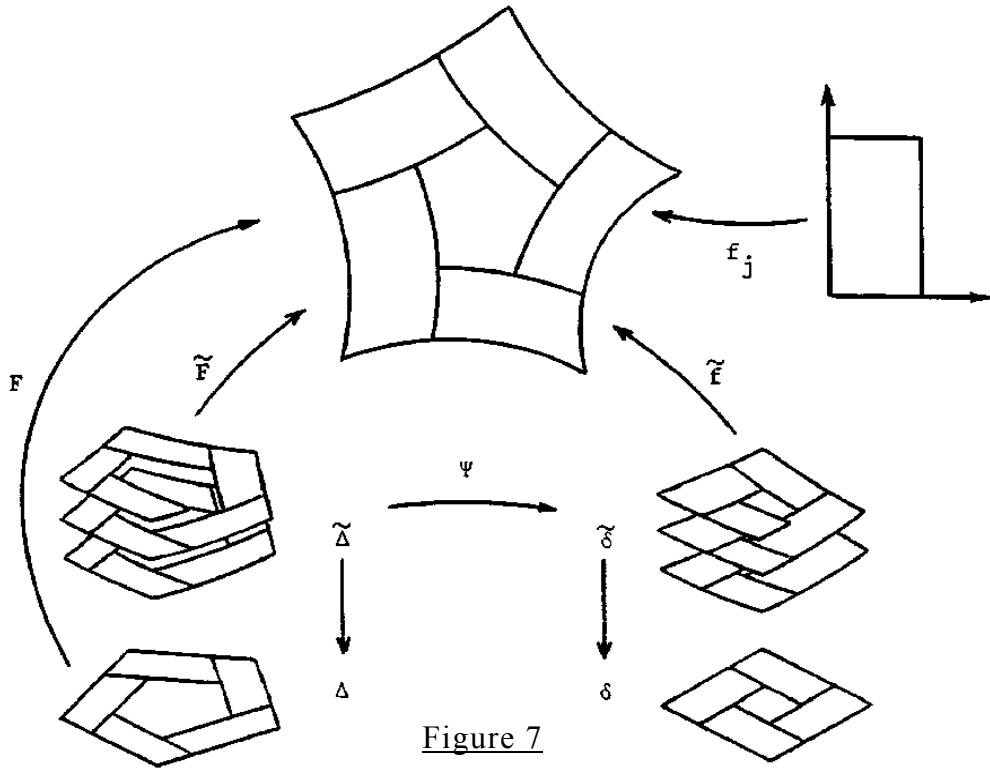

Figure 7

Now consider the universal covering of the exterior strip Δ around the polygon:

$$\tilde{\Delta} = \bigcup_{j \in \mathbb{Z}} \tilde{\Delta}_j, \text{ where } \tilde{\Delta}_j \text{ is projected on to } \tilde{\Delta}_j.$$

Then the coverings $\tilde{\Delta}$ and $\tilde{\delta}$ are diffeomorphic! This is the key that allows us to go from a rectangular framework to the polygon. Roughly speaking, a diffeomorphism $\Psi : \tilde{\Delta} \rightarrow \tilde{\delta}$ can be obtained by unwrapping the spirals.

Given a diffeomorphism $\Psi : \tilde{\Delta} \rightarrow \tilde{\delta}$, then

$$(3.4) \quad \tilde{F} : \tilde{f} \circ \psi$$

is a parameterization defined on the covering $\tilde{\Delta}$. Furthermore, assume that Ψ is such that

$$(3.5) \quad \psi(\tilde{\Delta}_j) = \tilde{\delta}_j$$

and that

$$(3.6) \quad \tilde{\tau}_i^1(\Psi(\tilde{X})) = \tilde{\tau}_j^1(\Psi(\tilde{Y})).$$

for any two points $\tilde{X} \in \tilde{\Delta}_i$ and $\tilde{Y} \in \tilde{\Delta}_j$ which are projected (under $\tilde{\Delta} \rightarrow \Delta$) to the same point $X \in A$. Then the "periodicity" of \tilde{f} implies that \tilde{F} is "periodic", i.e.

$$(3.7) \quad \tilde{F}(\tilde{X}) = \tilde{F}(\tilde{Y})$$

Hence $F : \Delta \rightarrow \mathbb{R}^3$ given by

$$(3.8) \quad F(X) := \tilde{F}(\tilde{X})$$

is well defined and c^k continuous.

F is the desired parameterization. To compute it explicitly only Ψ needs to be known. A special diffeomorphism will be constructed explicitly in Section 5. To simplify calculations, Ψ will be suitably tailored to the interpolation scheme involved.

4. Coordinates for interpolation along adjoining edges

The polygonal patch will be constructed as a convex combination of certain Boolean sum Taylor interpolants. The Taylor interpolants are computed using coordinates obtained by central projections (i.e. the "radial" projections of [Charrot and Gregory '84]), see Figure 8.

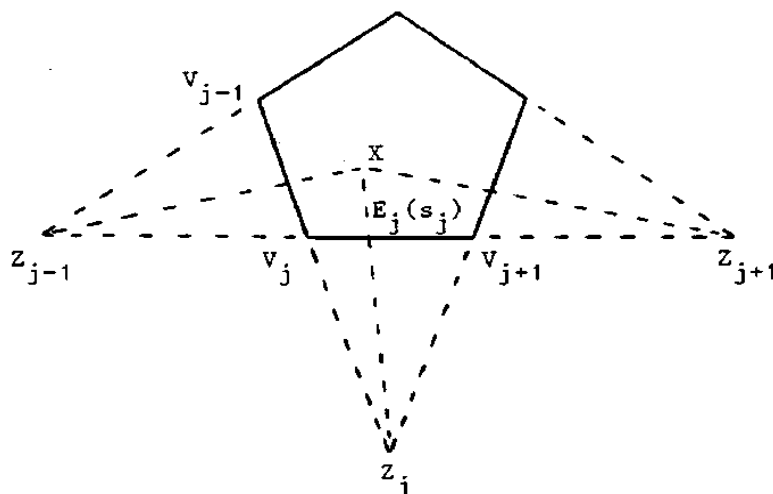

Figure 8

Let Z_j be the point of intersection of edge E_{j-1} with E_{j+1} and, for a point $X \in \Omega \cup \Delta$, let $s_j(X)$ be such that

$$E_j(s_j) := v_j + s_j (v_{j+1} - v_j)$$

is the point of intersection of the edge E_j with the ray from Z_j through X . It should be remarked that $E_j(s_j)$ is not defined for $X = Z_j$ but, since $n \geq 5$, we can assume that the width of the strip is such that $z_j \notin \Delta$. To treat the triangular case the central projections should be replaced by parallel projections, cf. [Gregory '86]. Let $t_j(X) = 1 - s_{j-1}(X)$. Then we define coordinate charts Φ_j on $\Omega \cup \Delta$ by

$$(4.1) \quad \Phi_j(X) := (s_j(X), t_j(X))$$

The chart Φ_j maps V_j to $(0,0)$ and the two edges E_j, E_{j-1} onto $(s,0)$ and $(0,t)$ respectively.

We now transform the parameterization F to the parameterization

$$(4.2) \quad g_j := F \circ \Phi_j^{-1}$$

defined on $\Phi_j(\Delta)$, see Figure 9. Boolean sum Taylor interpolation is then used in Section 7 to construct an interpolant, defined on $\Phi_j(\Omega)$, which matches g_j up

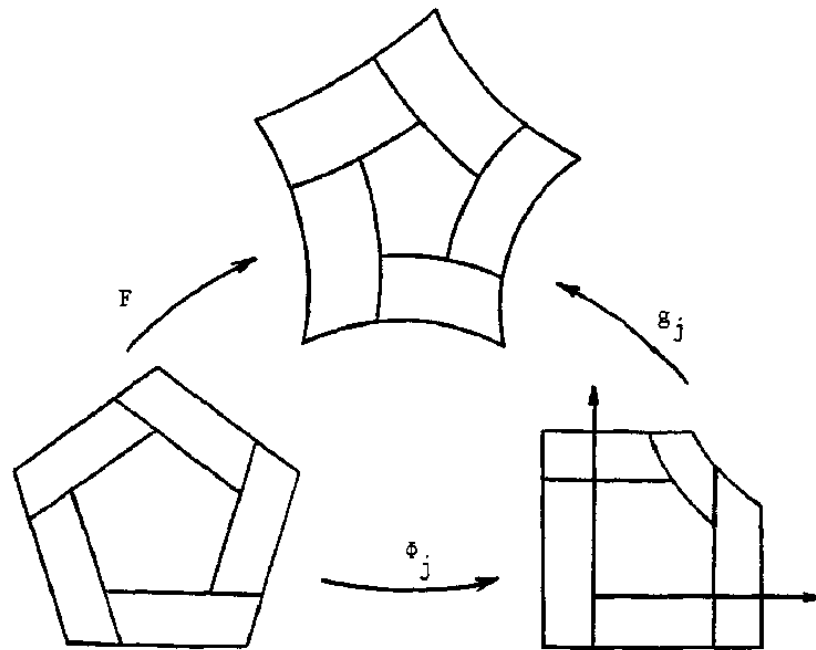

Figure 9

to its k -th derivatives along $(s,0)$ and $(0,t)$. The polygonal patch is a blend of such interpolants. However, we still have to construct the diffeomorphism Ψ , and the coordinate charts Φ_j will be used in this construction.

5. Construction of the diffeomorphism

The coordinate chart Φ_j transforms the angle at the vertex V_j to $\pi/2$. A similar property is needed of the diffeomorphism Ψ , which transforms the universal covering $\tilde{\Delta}$, of the polygon, to the universal covering $\tilde{\delta}$, of the square. Thus on the region $\tilde{\Delta}_j$ we construct Ψ as a kind of blend of Φ_j and Φ_{j+1} , suitably matched together to yield a global map.

The diffeomorphism Ψ is defined in terms of a local representation as follows: Let

$$(5.1) \quad (s_j, t_j) := \tilde{\Phi}_j(\tilde{X}) := \Phi_j(X),$$

where X corresponds to \tilde{X} under the projection $\tilde{\Delta} \rightarrow \Delta$. Then $\tilde{\varphi}_j$ defines a coordinate chart on $\tilde{\Delta}_{j-1} \cup \tilde{\Delta}_j$, of the universal covering of the polygon, which maps the vertex \tilde{V}_j to $(0,0)$ and the edges \tilde{E}_j and \tilde{E}_{j-1} to $(s,0)$ and $(0,t)$ respectively. Also, let $\tilde{\varphi}_j$ be the affine coordinate chart defined on $\tilde{\delta}_{j-1} \cup \tilde{\delta}_j$, of the universal covering of the square, which maps the vertex \tilde{V}_j to $(0,0)$ and the edges between $\tilde{V}_j, \tilde{V}_{j+1}$ and $\tilde{V}_j, \tilde{V}_{j-1}$ to $(s,0)$ and $(0,t)$ respectively. Then the diffeomorphism Ψ can be expressed

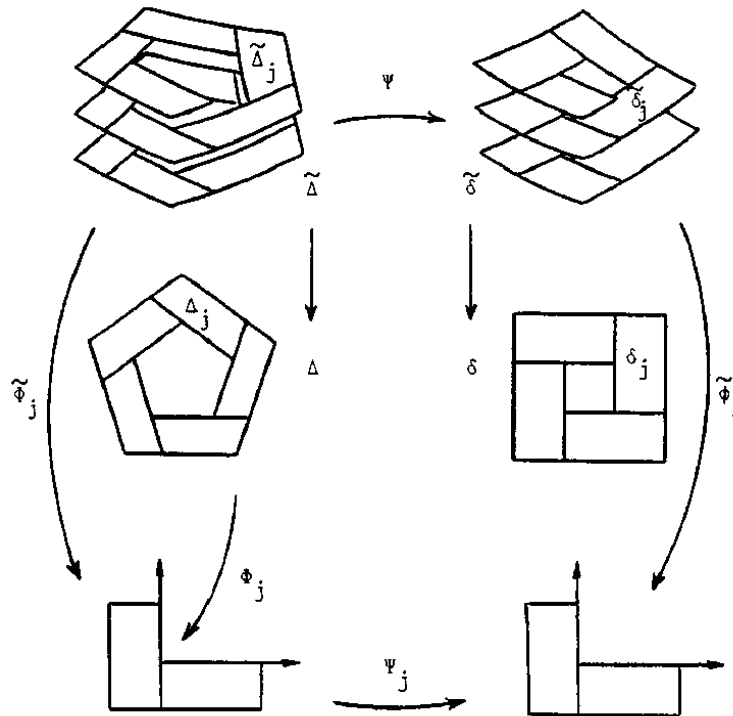

Figure 10

by its local representation

$$(5.2) \quad \psi_j := \tilde{\Phi}_j \circ \psi \circ \tilde{\Phi}_j^{-1},$$

with respect to the coordinate charts $\tilde{\Phi}_j$ and $\tilde{\Phi}_j$, see Figure 10

We now define ψ_j by the blend

$$(5.3) \quad \psi_j(s_j, t_j) = \begin{cases} (s_j, \alpha(s_j)t_j + \beta(s_j)s_{j+1}), & \text{for } s_j \geq 0, \\ (\alpha(1-t_j)t_{j-1} + \beta(1-t_j)s_j, t_j), & \text{for } s_j < 0, \end{cases}$$

where α, β are positive real-valued C^k functions such that

$$(5.4) \quad \begin{cases} \alpha(s) + \beta(s) = 1, \\ \alpha(s) = 1 \text{ for } s \leq 0, \\ \alpha(s) = 0 \text{ for } s \geq 1. \end{cases}$$

One easily checks that ψ_j is C^k . To show that ψ is well defined and C^k we must show that the local representations ψ_j and ψ_{j+1} describe the same map on $\tilde{\Delta}_j$.

This follows since on $\tilde{\Phi}_{j+1}(\tilde{\Delta}_j)$ we have

$$(5.5) \quad \begin{aligned} \tilde{\Phi}_{j+1} \circ \tilde{\Phi}_j^{-1} \circ \psi_j \circ \tilde{\Phi}_j \circ \tilde{\Phi}_{j+1}^{-1}(s_{j+1}, t_{j+1}) &= \tilde{\Phi}_{j+1} \circ \tilde{\Phi}_j^{-1} \circ \psi_j(s_j, t_j) \\ &= \tilde{\Phi}_{j+1} \circ \tilde{\Phi}_j^{-1}(s_j, \alpha(s_j)t_j + \beta(s_j)s_{j+1}) \\ &= \tilde{\Phi}_{j+1} \circ \tilde{\Phi}_j^{-1}(s_j, \alpha(s_j)t_j + \beta(s_j)s_{j+1}) \\ &= (\alpha(s_j)t_j + \beta(s_j)s_{j+1}, 1-s_j) \\ &= \psi_{j+1}(s_{j+1}, t_{j+1}). \end{aligned}$$

The diffeomorphism ψ satisfies the assumptions (3.5) and (3.6), except possibly that the range of ψ might be only part of δ , but this does not affect our construction.

6. Computation of the boundary data for interpolation

The function g_j can be computed on $\Phi_j(\Delta_{j-1} \cup \Delta_j)$ as follows:

$$(6.1) \quad \begin{aligned} g_j = F \circ \Phi_j^{-1} &= \tilde{F} \circ \tilde{\Phi}_j^{-1} = \tilde{f} \circ \psi \circ \tilde{\Phi}_j^{-1} \\ &= \begin{cases} \tilde{f}_{j-1} \circ \tau_{j-1}^{-1} \circ \tilde{\Phi}_j^{-1} \circ \psi_j & \text{on } \Phi_j(\Delta_{j-1}) \\ \tilde{f}_j \circ \tau_j^{-1} \circ \tilde{\Phi}_j^{-1} \circ \psi_j & \text{on } \Phi_j(\Delta_j) \end{cases} \end{aligned}$$

Therefore

$$(6.2) \quad g_j(s_j, t_j) = \begin{cases} f_{j-1}(-\alpha(1-t_j)t_{j-1} - \beta(1-t_j)s_j, 1-t_j) & \text{for } s_j \leq 0, \\ f_j(-\alpha(s_j)t_j - \beta(s_j)s_{j+1}, s_j) & \text{for } s_j \geq 0. \end{cases}$$

To compute derivatives of g_j we must calculate the coordinate change $s_{j+1} \circ \Phi_j^{-1}$ (and $t_{j+1} \circ \Phi_j^{-1}$). This requires some computations within the polygon Ω :

The coordinate chart $\Phi_j(X) := (s_j(X), t_j(X))$ can be computed as

$$(6.3) \quad (s_j, t_j) = \left(\frac{d_{j-1}}{d_{j+1} + d_{j-1}}, \frac{d_j}{d_{j-2} + d_j} \right)$$

Where

$$(6.4) \quad d_j(X) := \langle V_j - X, Z_j \rangle / \|Z_j\|$$

is the perpendicular distance of $X \in \Omega \cup \Delta$ from the side E_j , see Figure 11.

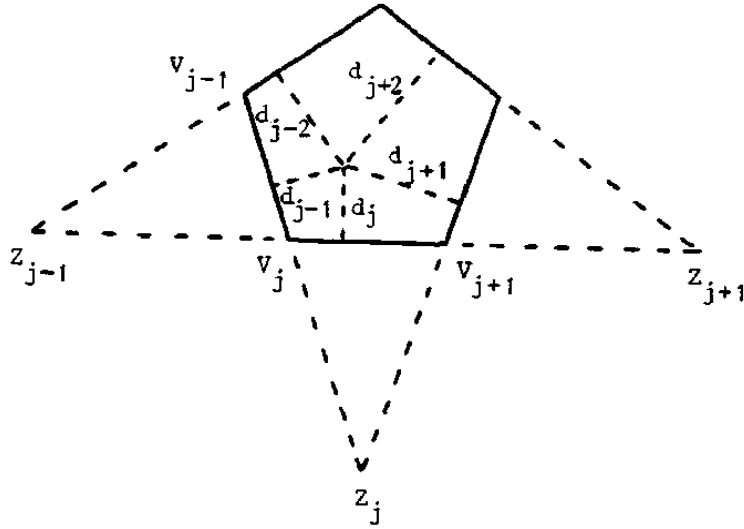

Figure 11

By considering the area of the triangle $V_j Z_j V_{j+1}$, we obtain the relations

$$(6.5) \quad d_{j-1} + d_{j+1} - 2d_j \cos \theta = \sin \theta, \quad j = 0, \dots, n-1,$$

where

$$(6.6) \quad \theta = 2\pi/n \quad .$$

Thus

$$(6.7) \quad \Phi_j(\mathbf{X}) = (s_j(\mathbf{X}), t_j(\mathbf{X})) = \left(\frac{d_{j-1}(\mathbf{X})}{2d_j(\mathbf{X})\cos\theta + \sin\theta}, \frac{d_j(\mathbf{X})}{2d_{j-1}(\mathbf{X})\cos\theta + \sin\theta} \right)$$

and

$$(6.8) \quad s_{j+1}(\mathbf{X}) = \frac{d_j(\mathbf{X})}{d_{j+2}(\mathbf{X}) + d_j(\mathbf{X})}$$

$$= \frac{d_j(\mathbf{X})}{2(2d_j(\mathbf{X})\cos\theta + \sin\theta - d_{j-1}(\mathbf{X})) + \sin\theta}$$

Eliminating d_{j-1} and d_j using (6.7) yields the following explicit formula for the coordinate change:

$$(6.9) \quad s_{j+1} \circ \Phi_j^{-1}(s, t) = \frac{t(1 + 2cs)}{4c^2t(1 - 2s) + 1 + 2c(1 - s)}$$

where

$$(6.10) \quad c = \cos\theta = \cos(2\pi/n).$$

Its derivatives can be computed quite easily. For example, the first and second partial derivatives with respect to t at $t=0$ are

$$(6.11) \quad \frac{\partial}{\partial t} (s_{j+1} \circ \Phi_j^{-1})(s, 0) = \frac{1 + 2cs}{1 + 2c(1 - s)}$$

and

$$(6.12) \quad \frac{\partial^2}{\partial t^2} (s_{j+1} \circ \Phi_j^{-1})(s, 0) = \frac{-8c^2(1 - 2s)(1 + 2cs)}{(1 + 2c(1 - s))^2}$$

Due to symmetry, the formula for t_{j-1} is obtained from (6,9) by permuting s and t

Thus

$$(6.13) \quad t_{j-1} \circ \Phi_j^{-1}(s, t) = \frac{s(1 + 2ct)}{4c^2s(1 - 2t) + 1 + 2c(1 - t)}$$

7. The basic polygonal patch

We now combine our results to exhibit the polygonal patch explicitly.

Define Boolean sum Taylor interpolants p_j on the unit square, that match the functions g_j up to its k -th derivatives along the edges $s = 0$ and $t = 0$, by

$$(7.1) \quad P_j(s, t) := \sum_{i_1=0}^K \frac{t^{i_1}}{i_1!} \partial_{0,i_1} g_j(s, 0) + \sum_{i_1=0}^K \frac{s^{i_1}}{i_1!} \partial_{i_1,0} g_j(0, t) \\ \sum_{i_1=0}^K \sum_{i_2=0}^K \frac{s^{i_1} t^{i_2}}{i_1! i_2!} \partial_{i_1, i_2} g_j(0, 0)$$

In fact, g_j is a $C^{k,k}$ function and its partial derivatives can be computed from (6.2), (6.9) and (6.13). For example, the data needed for a second order continuous patch are

$$(7.2) \quad g_j(s, 0) = f_j(0, s),$$

$$(7.3) \quad \partial_{0,1} g_j(s, 0) = \left(-\alpha(s) - \beta(s) \frac{1+2cs}{1+2c(1-s)} \right)^2 \partial_{1,0} f_j(0, s),$$

$$(7.4) \quad \partial_{0,2} g_j(s, 0) = \left(\alpha(s) + \beta(s) \frac{1+2cs}{1+2c(1-s)} \right)^2 \partial_{2,0} f_j(0, s) \\ + 8\beta(s) \frac{c^2(1-2s)(1+2cs)}{(1+2c(1-s))^2} \partial_{1,0} f_j(0, s),$$

$$(7.5) \quad g_j(0, t) = f_{j-1}(0, 1-t),$$

$$(7.6) \quad \partial_{1,0} g_j(0, t) = \left(-\alpha(1-t) \frac{1+2ct}{1+2c(1-t)} - \beta(1-t) \right) \partial_{1,0} f_{j-1}(0, 1-t),$$

$$(7.7) \quad \partial_{2,0} g_j(0, t) = \left(\alpha(1-t) \frac{1+2ct}{1+2c(1-t)} - \beta(1-t) \right)^2 \partial_{2,0} f_{j-1}(0, 1-t) \\ + 8\alpha(1-t) \frac{c^2(1-2t)(1+2ct)}{(1+2c(1-t))^2} \partial_{1,0} f_{j-2}(0, 1-t),$$

$$(7.8) \quad \partial_{1,1} g_j(0, 0) = -\partial_{1,1} f_j(0, 0),$$

$$(7.9) \quad \partial_{1,2} g_j(0, 0) = \partial_{2,1} f_j(0, 0),$$

$$(7.10) \quad \partial_{2,1} g_j(0, 0) = -\partial_{1,2} f_j(0, 0),$$

$$(7.11) \quad \partial_{2,2} g_j(0, 0) = \partial_{2,2} f_j(0, 0).$$

Here, α and β are c^2 functions such that

$$(7.12) \quad \alpha(s), \beta(s) \geq 0,$$

$$(7.13) \quad \alpha(s) + \beta(s) \equiv 1,$$

$$(7.14) \quad \alpha(0) = 1, \dot{\alpha}(0) = \ddot{\alpha}(0) = 0,$$

$$(7.15) \quad \beta(1) = 1, \dot{\beta}(1) = \ddot{\beta}(1) = 0,$$

and $c = \cos(2\pi/n)$ (see (6,10)).

Interpolants P_j on the polygon, which match the function F along the two edges meeting at the vertex V_j , are defined by

$$(7.16) \quad P_j(X) := P_j(s_j, t_j),$$

where s_j, t_j are computed by (6,3) using the parameters d_i from (6.4). The final polygonal patch is a convex combination of these, namely

$$(7.17) \quad P(X) := \sum_{j=0}^{n-1} w_j(X) P_j(X),$$

where w_j are weight functions that sum to unity and vanish up to order k along the edges E_i , $i \neq j, j-1$. An appropriate definition of the weight functions for a C^k patch is

$$(7.18) \quad w_j(X) := \frac{\prod_{i \neq j, j-1} d_i^{k+1}}{\sum_{\ell=0}^{n-1} \prod_{i \neq \ell, \ell-1} d_i^{k+1}}$$

8. Examples and modifications of the basic patch

The basic polygonal patch defined in Section 7 allows for a wide variety of modifications:

The union of P and F is an explicit C^k parameterization defined on $\Omega \cup \Delta$. This means that P and the rectangular patches f_j , $j=0, \dots, n-1$, join with geometric continuity of order k (GC^k), see [Gregory and Hahn '86]. However, parametric continuity between P and F is not necessary for a C^k surface. It suffices that they join with GC^k continuity and this permits some interesting simplifications described in subsections 8.1 and 8.2. In subsection 8.3 we consider an alternative to the Boolean sum Taylor interpolant (7.1). Finally, in subsections 8.4 and 8.5 we describe some handles for shape control.

8.1 The Charrot-Gregory GC^1 patch

GC^1 continuity of P and F is preserved if the cross boundary derivatives of g_j are replaced with a positive multiple. Thus replacing (7.3) and (7.6) with

$$(8.1) \quad \partial_{0,1} g_j(s, 0) = -\partial_{1,0} f_j(0, s),$$

$$(8.2) \quad \partial_{1,0} g_j(0, t) = -\partial_{1,0} f_{j-1}(0, 1-t),$$

and with $k = 1$ in (7.1) and (7.18), gives the original Charrot-Gregory GC^1 patch.

8.2 A simplified GC^k patch

GC^k continuity ($k \geq 2$) is not affected if the k -th derivative of P across the boundary is modified by adding a tangent term. This was proved in [Gregory and Hahn '86] for the case $k = 2$ but, in fact, the proof also applies to the general case. This observation can be used to cancel the first derivative terms of f_j (and f_{j-1}) in the expression for $\partial_{0,k} g_j(s,0)$ (and $\partial_{k,0} g_j(0,t)$). For second order continuity, this means that (7.4) and (7.7) can be replaced by

$$(8.3) \quad \partial_{0,2} g_j(s,0) = \left(\alpha(s) + \beta(s) \frac{1+2cs}{1+2c(1-s)} \right)^2 \partial_{2,0} f_j(0,s)$$

$$(8.4) \quad \partial_{2,0} g_j(0,t) = \left(\alpha(1-t) \frac{1+2ct}{1+2c(1-t)} + \beta(1-t) \right)^2 \partial_{2,0} f_{j-1}(0,1-t)$$

and the resulting patch is still GC².

8.3 An alternative interpolation scheme

The Boolean sum interpolation technique in (7.1) cannot be applied if the surrounding patch framework is just C^k (not $C^{k,k}$). However, in this case any C^k interpolant which matches the function g_j up to its k -th derivatives along the edges $s = 0$ and $t = 0$ would be appropriate. For example, if the individual patches f_j are $C^{k,k}$ but the composed map is only C^k at the corners (i.e. (2.3) holds only for $i_1 + i_2 \leq k$), then an interpolant can be defined by

$$(8.5) \quad P_j(s,t) := \frac{s^{k+1}}{s^{k+1} + t^{k+1}} \sum_{i=0}^K \frac{t^i}{i!} \partial_{0,i} g_j(s,0) \\ + \frac{t^{k+1}}{s^{k+1} + t^{k+1}} \sum_{i=0}^K \frac{s^i}{i!} \partial_{i,0} g_j(0,t)$$

Although the weights are singular at $(0,0)$, it can be shown that p_j is C^k continuous on the unit square and can therefore replace (7.1).

8.4 Prescribing the shape across a boundary

The effect of the adjoining rectangular patches can be varied individually by changing the diffeomorphism ψ . The conditions (5.4) can be weakened. The blending functions α and β need not sum to unity everywhere, and moreover, they can depend on the index j in (5.3). For a second order continuous patch this means that (7.13), (7.14), (7.15) can be replaced by

$$(8.6) \quad \alpha_j(0) = \beta_j(1) = 1,$$

$$(8.7) \quad \alpha_j(1) = \beta_j(0) = 0,$$

$$(8.8) \quad \dot{\alpha}_j(0) = \ddot{\alpha}_j(0) = \dot{\alpha}_j(1) = \ddot{\alpha}_j(1) = 0,$$

$$(8.9) \quad \dot{\beta}_j(0) = \ddot{\beta}_j(0) = \dot{\beta}_j(1) = \ddot{\beta}_j(1) = 0.$$

Then α, β have to be substituted by α_j, β_j in (7.3), (7.4) and by $\alpha_{j-1}, \beta_{j-1}$ in (7.6), (7.7).

A further generalization is possible in that the blending functions $\alpha(s)$, $\beta(s)$ in (5.3) might be replaced by bivariate functions $\alpha_j(s, t), \beta_j(s, t)$.

8.5 Prescribing the shape in the interior

A function may be added to the right hand side of the patch definition (7.17) which vanishes up to its k-th derivatives along the boundary of Ω . Such a function is given by

$$(8.10) \quad Q(X) \prod_{j=0}^{n-1} d_j(X)^{k+1}.$$

The function Q might be chosen to prescribe the position of the centre point P(0), to adjust the tangent plane at P(0), etc. It can thus be used to control the interior shape of the patch.

References

- Charrot, P. and Gregory, J.A. (1984), A pentagonal surface patch for computer aided geometric design, *Computer Aided Geometric Design* 1, 87-94.
- Gregory, J.A. (1986), N-sided surface patches, in J.A. Gregory, ed., *The Mathematics of Surfaces*, Oxford, 217-232.
- Gregory, J.A. and Hahn, J.M., Geometric continuity and convex combination patches, to appear in *Computer Aided Geometric Design*.
- Singer, I.M. and Thorpe, J.A. (1967), *Lecture Notes on Elementary Topology and Geometry*, Scott, Foresman and Co., Glenview, Illinois.

