

A measure of subsea systems' readiness level

Sirous F. Yasseri
Brunel University, London

Received 29 February 2016; Accepted 21 April 2016

Abstract

Systems readiness level (SRL) is a metric for assessing progress in developing major subsea systems. SRL methodology builds on technology readiness levels (TRLs), developed by American Petroleum Institute (API) 17N to assess the readiness of subsea components for insertion. To estimate the level of readiness of a system comprising multiple components in their current state, SRL combines the TRL of each component with another metric called the integration readiness level (IRL). This metric expresses the readiness of each of these components to be integrated with other components of the system. An averaging approach is then used to estimate an overall level of systems readiness if these components were to be used. This paper presents a distillation of experience gained in applying the readiness metrics to subsea systems by the author and others. The methodology for determining the progress of a typical subsea system development, using TRL, IRL and SRL metrics is illustrated using a typical subsea system.

Key words: subsea production systems; technology readiness level; integration readiness level; system readiness level

1. Introduction

Technology readiness level (TRL) was originally developed for NASA as a metric to measure the maturity and usability of an evolving technology (Olechowski et al., 2015). It is increasingly used by many industries and businesses around the world for the purpose of measuring progress. TRL helps decision-makers to decide whether and when to integrate a technology into a larger system. The TRL scale was embraced by the subsea industry following publication of American Petroleum Institute (API) RP 17N (2009) and Det Norske Veritas (DNV) RP-A203 (2011) recommended practices.

The TRL scale originates from the observation that subsea system planning, design, fabrication, testing and commissioning requires a common language for communication and synchronisation. The successful development of a system depends on the successful management and alignment of the individual technology needed, as well as the synchronised development of those technologies. There is also a need for standardised, systematic and shared understanding for managing procurement and reducing risks, in order to provide a highly reliable and available system that is fit for the field.

The TRL scale is one of such tools, as it helps all stakeholders have a shared understanding of where the technology stands. It is not intended to check if the choice of a component is fit for purpose, or the design delivers what the customer wants. Instead, it is the step-by-step realisation of parts designed for the total system (see Table 1).

Assigning a TRL rank is not a quick task. There are some questions that need to be answered and backed by evidence. An illustration of this shown in Table 2 in a subsea production system (SPS) context. The benefits and limitations of TRLs lie mainly in how they are used, rather than the concept itself. Some key points are noted in Table 3.

The terms 'system readiness' and 'system maturity' are used interchangeably in this paper. Smith (2005) made a distinction between readiness and maturity by noting that a system considered mature in one context may not possess sufficient readiness for operation in a different environment. Bilbro (2007), however, used 'maturity' as part of the definition of 'readiness' and thereby implied a relationship between the two terms. Various authors also used the terms interchangeably (e.g. Azizian et al., 2009; Azizian et al., 2011). Tetlay and John (2010) noted that definitions of system readiness inherently included maturity as a component term.

* Contact author. Email address: sirous.yasseri@gmail.com

2. Technology readiness level

The API's TRL scale is a sequential approach to subsea development and implementation. TRL concentrates on individual technology (i.e. component or subsystem) that is being developed and is to be integrated with other components/subsystems in a

Table 1: Primary objectives of TRLs

- Items not directly associated with SPS operations do not have TRLs. Work that is being carried out to support technology development such as front-end engineering, concept selection studies, report writing, simulations, modelling, etc. do not have TRLs.
- TRLs are time-specific. Technologies are assessed based on their readiness to be inserted into an SPS at the assessment. They explain what risk there might be if the technology is to be used today. They do not necessarily convey accurate information about the future.
- TRLs are context-specific. A technology that is mature in one field cannot be assumed to be as mature in a different one. Even those that appear the same, might have significantly different operating conditions.
- The TRL scale is an ordinal scale. The ratings are in order but the distinction between neighbouring levels on the scale is not necessarily the same. For example, one cannot infer that it 'only takes about 10 % of effort to move from one level to another level'.
- The TRL scale is qualitative.

Table 2: Questions to resolve while deciding on the TRL rank

- Is technology (equipment) widely used by the company?
- Is technology demonstrated in the final form (in a system somewhere in the world)?
- Is technology demonstrated in the relevant environment (field conditions)?
- What is the target performance/efficiency level (technically and economically)?
- What is currently achieved performance/efficiency?
- What are the materials involved, and what is their availability and suitability?
- Is infrastructure available for deployment for this technology?
- What are the main barriers impeding higher performance?

Table 3: Benefits and limitations of TRLs

| TRL benefits | TRL limitations |
|--|--|
| <ul style="list-style-type: none"> • Provides a common understanding of state of readiness of equipment to be inserted into a system at the present time. • Helps to identify areas requiring management's attention. • Provides part of the evidence for the staged-gate approval process, i.e. if the project is ready to move to the next stage. • Helps to initiate discussions and whether certain avenues are worth pursuing. • Can help to identify the project's technical risks. • Are only a measure of an individual component not the SRL. | <ul style="list-style-type: none"> • Can be a measure of technical risk, only if the proposed technology is planned to be introduced into an SPS at the present time. • Does not necessarily convey accurate information about risk, cost and schedule if the technology is being developed for use at a future date. • Relates to individual technologies and does not suggest that the individual technologies can be integrated and will work together. • Does not indicate that the technology is right for the job or that application of the technology will result in successful development of the system. |

broader subsea system. The TRL scale is used as an evaluation and planning tool to assess the readiness for insertion of individual components and communicates on the status of all components, using a shared language. TRL usage in the context of subsea engineering is not the same as used by NASA; API adapted it to assess the readiness of every component to be inserted into the system. Clearly, the wording and definition of the individual levels are different from NASA's 9 level TRL scale. API distinguishes three development levels: concept validation (TRL0-2), technology validation (TRL3-5), and system validation (TRL 6-7). This adaptation fulfils the needs of the sanctioning authority for a harmonised scale to monitor the state of progress in a vast investment project.

Acceptable technology maturity has often been the principal driver, particularly in systems where availability is fundamental to the customer requirements. While technology and system development theoretically follow similar maturation paths, ultimately technology is inserted into a system based on its maturity, functionality and environmental readiness, as well as its ability to integrate with the intended system.

Basically, any system under development is composed of core technology components and their linkages, or relationships, which is the system's architecture. Various engineering failures underlines the fact that projects often fail because attention is exclusively focused on the technology, while the importance of the linkages/relationships is overlooked. While TRL provides the metric for describing components' maturity status, it would still be ideal to have a metric that provides a description of integration (i.e. how components relate to each other). There have been some efforts to develop metrics that can be used to evaluate integration maturity, however, it is vital that all stakeholders have the same understanding of such a metric and

that it can also be used with TRL to potentially determine a system maturity.

In response to this, Yasseri (2013) created an integration readiness level (IRL) for subsea systems to measure integration maturity on a scale similar to API's TRL, with the objective that it could be combined with TRL to provide a system-level readiness. Assessment of the readiness of the individual technologies will contribute to risk reduction in budget and planning.

3. State of practice

Beyond the definition of TRL levels, API 17 N (2009) and DNV-RP-A203 (2011) do not give any underlying guidance. Therefore, evaluations vary widely, and companies have implemented their own processes for evaluation. The primary design contractor is required to identify technologies' maturation by TRL, but equipment readiness level assignment is typically left to the fabricator.

Except for involvement through joint industry research partnerships, the subsea industry does not usually focus on TRL 0 to 2. Even innovative SPS starts from TRL 4. Most successful innovations are improvements on the existing technologies and products, namely finding the best way to fix a particular problem. However, this still needs a great deal of research and experimentation to extend the application principles that have been proven to work, but have not been exploited yet. Table 4 presents a collation of problems encountered and decisions made by subsea industry professionals when assigning appropriate TRL to their project at the right time.

Achievement of TRL 4 is one of several pieces of evidence that is presented to the sanctioning authority in a stage-gate process (Fig 1) to help in its decision-making process in committing to the major capital investment (Yasseri, 2014). TRL 5 arguably is the most important stage during the SPS development process, since the technology readiness assessment (TRA) involves not only the demonstration of

Table 4: Judgment in assigning TRLs

| Action | Commentary |
|--|---|
| TRL assigned once the description in the diagram has been achieved (Fig 2). | For example, when a technology successfully achieves TRL 4, it does not move to TRL 5. Compliance with requirements of TRL 5 should be conclusively established by validation. |
| TRL assigned for equipment consisting of a number of sub-components or subsystems with their own TRLs. When a component/element in an equipment/technology is altered. | The higher level assembly is assigned with the lowest TRL level among its components. The equipment is only as good as its weakest link. Previous TRL rankings become invalid. When one replaces, eliminates or adds a major component or part, even in a TRL 7, everything starts all over again, usually from a TRL between 1 and 4. The previous TRL rank cannot not be claimed if there is an attempt to integrate a technology into a different system |
| If the primary use of the technology changes. | Even a TRL 7 technology requires re-confirmation due to the probable changes in the conditions (e.g. data, know-how and environment) that was the basis previous TRL ranking. |
| If the technology spends too much time at a given TRL, validating the TRL rank again. | Some technologies may evolve faster than others, or a particular technology may pass some levels in weeks but the others in years. Requirements for a project that was decided at TRL 2 stage a while ago may be subject to change. |
| Basing activities and progress through TRLs on equal time. | |
| Change in verification and validation criteria of technology for TRL ranking over time as more information becomes available. | |

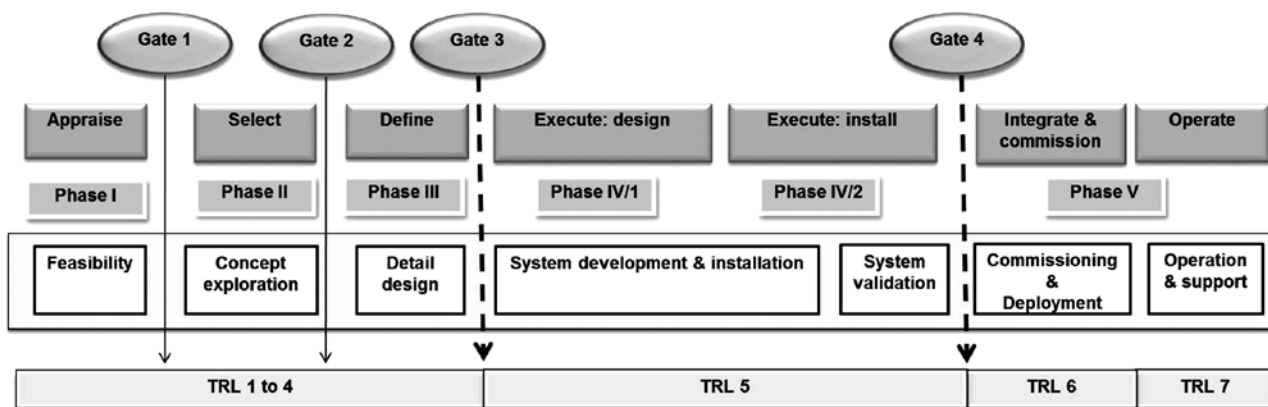

Fig 1: Timeline for stage-gating in a subsea development

readiness of all necessary components, but also that the components work together as a system.

TRL 5 is the maturity level necessary before a technology can be inserted into the final system. At TRL 5 stage, several components are integrated into an assembly at the quayside, tested and made ready for installation. In API's utilisation of TRLs, achieving a TRL of 5 is a prerequisite for the integration and installation of assemblies. Validation at this level must go beyond discrete component level; it must consider testing the assembly of components (or subsystems) and testing at the quayside in shallow water (i.e. a relevant environment) and/or the operational environment. TRL 5 is a major transition from components and factory testing to installation readiness and integration testing of assemblies and subsystems.

From TRL 6 onwards, the maturing assessment is not based on individual components, but on the system itself. Only the overall evolving system is given emphasis, and a single TRL rank refers to the system maturation. Thus, everything revolves around proving if the system has achieved all the requirements of the rank. TRLs 6 and 7 are associated with integration testing, commissioning and operations. Table 5 lists questions that require satisfactory answers, backed with evidence, before moving to installation and integration of the system.

Most of items used in SPS are bespoke, but some are commercially available off the shelf (COTS) components. These may have been previously used by the company in the same region or somewhere else, or used by another company or industry somewhere in the world. COTS components enter the project at TRL 4 but must be transitioned to TRL 5

Table 5: Checklist for TRL 5

Questions to be asked at TRL 5

- Operating conditions and environment are understood. All operating scenarios have been investigated including the process upsets (off normal condition).
 - Materials and equipment are suitable for the environment, fluid and system.
 - Operating limits for equipment are determined.
 - Availability level established.
 - Reliability, maintainability and supportability are known.
 - Drawings are complete.
 - Hardware availability is acceptable.
 - Interfaces are tested and an integration testing plan in place.
 - Factory acceptable test, shallow water tests or acceptance testing at the quayside have been performed.
 - Procurement programme, schedules, costs and mile stones are established.
 - Operating manuals and the installation safety manual, as well as emergency procedures are prepared.
 - Regulatory permission is in place.
 - Installation contractors, testing and commission contractor are signed on.
 - Decommissioning requirements identified.
-

before they can be inserted. There are also technologies that other operators use (e.g. subsea compression or separation), but equipment for the technology may need to be re-sized (re-designed) for the project's specific use. Such equipment enters at TRL 4, if not 3. Transitioning COTS items through TRL 5 requires different amounts of effort depending on the item. Table 6 lists a few examples.

4. Integration readiness level

Although the TRL metric has been endorsed by many industries, it captures only a small part of the information that a sanctioning authority needs to support its decisions. Other maturity assessment metrics have been developed to complement TRL (Sausser et al., 2008; Sausser et al., 2010; Yasseri, 2013).

The TRL scale is component oriented. One limitation of TRL is its focus on individual technologies (components) in isolation, as the primary use of the TRL scale is to align different technology developments and move them along the same timeline/pathway. However, the higher TRL levels are about integrating different individual technologies, possibly with different maturities, into a complex SPS. This means that the original TRL scale is not used to assess maturity of a SPS, but it is focused on one of its components (e.g. valves in manifold). This complicates the application of the higher TRL levels to projects. Further, attention to non-component aspects, like the readiness of the installation contractor to implement the system, is not incorporated. In some cases, this could mean a higher level SPS may be in the hand of a contractor with equipment stuck in a lower level TRL, or there may be limitations on available equipment operating in the region of interest. This fact must be addressed at the lower level TRL, as it could severely limit the progress of the project.

Using the TRL tool to characterise the evolutionary maturity of a specific component of a system focuses on the physical installation of the system under development. This works well for the physical dimension of the integration, but does not provide insight into the functional and logical dimensions of the overall system. The integrator must also be interested in what goes in between the components in order to achieve the required behaviour of the system. To address this problem a new readiness level – the integration readiness level (IRL) – has been introduced to specifically focus on the relationship between components, and is designed to work in concert with the TRL (Yasseri, 2014).

The IRL metric is a systematic analysis of the various interfacing technologies and the consistent

Table 6: Examples of assigning TRLs to COTS components

| Item | Description | TRL |
|--|---|--------------|
| COTS : same operator and vendor | The item is commercially available and used by the company. The operational conditions (hydrocarbon mix, volumes, maintainability, etc.) are comparable to its intended use. Since it is not expected that there will be any modifications and the component is expected to work within the expected operational conditions, then the product would simply require integration testing before commissioning. The vendor should be able to provide evidence demonstrating the technology working, with the comparable process conditions, in a similar environment. | TRL 5 |
| COTS: different operator no modifications | The item is in use somewhere (by a different operator) for a similar situation, although the operational conditions (hydrocarbon composition, volumes, maintainability, etc.) are different. There is a high degree of confidence that the item will not require modification. Although the item is not expected to require modification, it will still need to be tested at full-scale with similar operational conditions. Evidentiary information on the equipment should be available, albeit under different operating or environmental conditions. | TRL 5 |
| COTS: needs minor modification | The item is in use in one of the companies SPS, or by a major operator somewhere in the world for a similar function where the operational conditions (hydrocarbon, volumes, maintainability, etc.) are different. It is known that modifications are required, but these are well understood because something similar has been done elsewhere. Evidentiary information should be available, albeit under different conditions and with known modifications. Equipment will be tested at a pilot scale. The development plan could be complex, since the modifications could alter the operability of the item. It could take some time to move from TRL 4 while designs are developed and tested. | TRL 4 |
| COTS: needs extensive modification | The item is in use elsewhere (either by the company or another operator) for a similar function where the operational conditions (hydrocarbon, volumes, maintainability, etc.) are different. It is known that extensive modifications are required and that these are not well understood. Required modifications may affect the final design of the item considerably. There is every reason to expect success, since the science and engineering is understood. Evidentiary information on the equipment should be available along with the expected modifications. | TRL 3 |
| New component using COTS | The individual items are used elsewhere (either by the company or another operator), but they need to be brought together for a new function. The individual items maybe well known, but the integration of them is not. Evidentiary information on the individual equipment should be available, along with the expected modifications required for bringing them together. | TRL 2 |

comparison of the maturity between integration stages. The eight levels of IRL presented in Fig 2 can be understood as having three stages of integration definition. IRL 0 to 2 are considered fundamental to the three principles of integration: interface, interaction and compatibility. It can be contended that these three principles are fundamental to an integration effort. IRLs 3 to 5 are about assurance that an integration effort is in compliance with specifications. The final stage relates to practical considerations, namely IRLs 6 and 7 which are about the integration and validation testing of the entire system.

SPSs are tightly interconnected systems of systems that demand the integration of components to be closely monitored. IRL metric provides a mechanism to continually monitor the maturation of the system. IRLs provide:

- an integration specific metric to determine the integration maturity between two or more configuration items, components and/or subsystems;
- a means to reduce the uncertainty involved in maturing and integrating a technology into a system;
- the ability to consider the meeting of system requirements in the integration assessment, so as

to reduce the integration of obsolete technology over less mature technology; and

- a common platform for both new system development and technology insertion maturity assessment.

It should be noted that, similar to the TRL process, this process on its own will not eliminate the project's technical risk. However, it will identify low level integration ready items leading to risk.

The need to use IRL is becoming increasingly more relevant as operators attempt to harmonise their acquisitions from multiple vendors with different interfaces with possible oversight of interface requirements. IRL is devised to capture inconsistencies at an early stage. As such, IRL is an integration tool to complement TRL, but IRL must be done independent of the TRL process to be useful.

5. System readiness level

Technology readiness assessment (TRA) process does not capture the requirements of integration. A system with mature technology does not automatically equate to having a high IRL when interfacing with another system with mature technology. IRL is used as an intermediate step; combining it with TRL produces a single metric that can be used to

| Phase | TRL | Development stage | IRL | Development stage | SRL | Development stage |
|-----------------------|-----|--|-----|--|-----|---|
| System validation | 7 | Field proven: production system field proven. | 7 | Integration is field proven through successful operations. | 7 | Field proven operational system. |
| | 6 | System installed: production system installed and tested. | 6 | Integration is completed and qualified through sufficient and rigorous testing in the marine environment. | 6 | The system is installed tested. Commissioning in progress. |
| Technology validation | 5 | System tested: production system interface tested. | 5 | The integration has been verified and validated with sufficient detail for the system to be deployable. | 5 | Manufacturing and installation in progress. |
| | 4 | Environment tested: preproduction system environment tested. | 4 | There are sufficient details to assure inter-operability between technologies necessary to establish, manage and assure the integration. | 4 | Detail design and final procurement. |
| | 3 | Prototype tested: system function, performance and reliability tested. | 3 | There is sufficient detail in the control and assurance of the integration between technologies to deliver the required functionality. | 3 | Front end engineering, sourcing of long lead items. |
| Concept validation | 2 | Validated concept: experimental proof of concept using physical model tests. | 2 | There is sufficient evidence of compatibility between technologies within the system. Namely, they will work together and can be integrated with ease. | 2 | Concept selection: an optimal concept has emerged. |
| | 1 | Demonstrated concept: proof of concept as desk study or R&D experimentation. | 1 | There is some level of specificity to the system functionality to allow identification of linkage between technologies. | | Concept refinement: two or more competing concepts being considered. |
| | 0 | Unproven concept: basic research and development (R&D) in papers. | 0 | The interface, i.e. the linkage, between technologies can be identified/characterised with sufficient clarity. | 0 | Concept definition: various ideas are being considered or discounted. |

Fig 2: Definitions of TRL, IRL and SRL

judge the system readiness level (SRL). However, IRL on its own has a significant assessment value, and the IRL level may be influenced by what is needed to achieve an SRL level (Fig 2).

SRL is an evidence-based project management tool for assessing and communicating system maturity to stakeholders. SRLs define a set of eight maturity steps from concept to operation, by tracking the project's progress as it going to various phases of development.

To combine TRL with IRL, arithmetic operations must be performed. TRL and IRL are ordinal

scales – that is, each of TRL or IRL level is a rank. The arithmetic operations can only be meaningful when it is performed on the interval and/or the ratio scales (Kujawski, 2010). The logic behind the matrix operation to combine TRLs and IRLs into SRLs is not obvious (McConkie et al., 2013), and many other arithmetic operations have been proposed on TRL (e.g. Dacus, 2012). Methods requiring arithmetic operation on ordinal numbers can give reasonable results, provided the inputs belong to the same range (within or around the same rank). Problems can arise if the range is pushed to

the extreme, e.g. averaging TRLs of two components with a TRL 2 and TRL 5, respectively. See Appendix A for a discussion of ordinal numbers.

SRL is a metric of maturity applied at the system-level with objective of combining TRL with IRL and correlating this indexing to system maturity. A table of SRL is proposed by Yasserli (2013, see Fig 2), alongside a method for combining TRL and IRL to determine an *estimated* SRL. Comparison of the estimated SRL and values in the SRL table indicates the level of system maturity. These three indices can provide part of the required information for the sanctioning authority to prove if the project can move through a gate to the next phase of development in a stage-gated process.

The square root of mean of squares (RMS) method is used in this paper (see Appendix B). Root mean square (RMS) gives numerically higher value than the simple mean. As a result, RMS reflects (qualitatively) better the level of effort gone into reaching the level where the system is, or effort needed to attain the target level.

Technology, integration and systems development follow similar evolution (or maturation) paths. A technology is inserted into a system based on its maturity, functionality, environmental readiness and ability to integrate into the intended system. Thus, IRL and TRL are either at the previous level or have achieved the requirements of the target level, thus RMS will show an SRL that is sandwiched between the highest and the lowest TRLs.

6. System mapping

A system may be a single component or several components linked together and can be mapped in different ways, depending on the overall goal. A sketch of the arrangement of components is known as the system architecture. It also includes the relationships between components and essentially provides the context to a TRL. To construct a system map, identifying the overall purpose and a list all the systems' components as well as their relationships are required. This list is referred to as a system breakdown structure (SBS). The system map shows where each component is located and how they are linked together, namely their interdependencies. Components within the system will, themselves, be made up of smaller components. These are called subsystems and can also be represented in a separate map, linked to the primary map, if any of them are particularly complex.

Fig 3 shows a typical subsea isolation valve (SSIV) in some detail. This SSIV will be inserted in an example subsea system described later in this paper. However, all similar components of this SSIV are

grouped into one for the purpose of illustration. One way to map the SSIV is the design structure matrix (DSM, also known as dependency structure matrix). DSM is a square matrix for visual representation of a system (Eppinger and Browning, 2012; Browning, 2016; Yasserli, 2015b), which shows both components of the system and linkages between them. It is the equivalent of an adjacency matrix in graph theory, and is used in systems engineering and project management to model the structure of complex systems (Eppinger and Browning, 2012; Eppinger et al., 2014), in order to perform system analysis, project planning and organisation design. The system elements are often labelled and are shown in a row of the matrix and in a column on the left of the matrix. These elements represent subsystem, components or project activities.

In Fig 3, components are labelled from D to J. Fig 4 shows a DSM representation of the SSIV of Fig 3. Components of the SSIV are entered in the top row as well as in a column to the left of the Fig 4. The off-diagonal cells are used to indicate relationships between the elements.

The Xs indicate the existence and direction of information flow or a dependency of one component on another. Reading across a row reveals the input/dependency flows by an X placed at the intersection of that row with the column that bears the name of the input task. Reading across a column

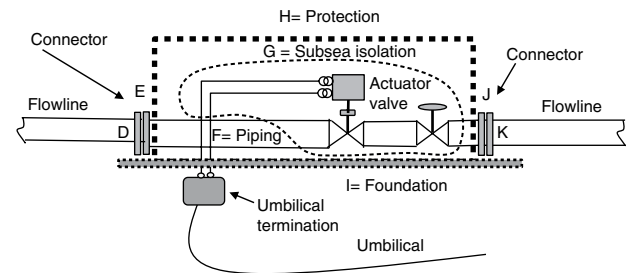

Fig 3: Schematic of an SSIV used in the SPS system shown in Figs 5 and 6

| Components | D | E | F | G | H | I | J | K |
|---------------------|---|---|---|---|---|---|---|---|
| Connectors (female) | D | X | | | | | | |
| Connectors (male) | E | X | X | | | | | |
| Piping | F | X | X | X | X | | X | |
| SSIV | G | | X | X | | | | |
| SSIV Structure | H | | X | | X | X | | |
| SSIV Foundation | I | | | | X | X | | |
| Connectors (female) | J | | X | | | | X | X |
| Connectors (male) | K | | | | | | X | X |

Fig 4: A DSM representation of the SSIV. Labels D to J are defined in Fig 3

reveals the output information flows from that component to another component by placing an X in a similar manner. For example, in the DSM (Fig 4), the marking in row D and column E indicates a dependency between them (D must integrate with E). The cells along the diagonal are typically used to represent the system elements and their interface requirements (Browning, 2001; Browning and Eppinger, 2002; Yasseri, 2015a).

Marks below the diagonal represent forward flow of information and marks above the diagonal represent feedback from a later downstream task to an earlier or upstream one. This means that the earlier task has to be repeated in light of the late arrival of new information, thus making the processes iterative. Design iterations create rework and require extra communications and negotiation. The DSM methodology suggests the manipulation of the matrix tasks so that iterative behaviour is removed from the matrix, or at least minimised. A process called partitioning is used to achieve this. However, any rearranging makes no difference for the purpose of this paper.

The decision regarding the level of detail required for a system map is dependent on the technologies being developed. In many cases, a tiered approach is required, starting with a super-system diagram and then a system diagram for individual plants or facilities possibly linked together. For complex, highly integrated equipment, subsystem

diagrams may be required to highlight aspects of a piece of equipment within an assembly of the system that requires development.

7. Case study

A system is an aggregation of components enabling links to achieve a given purpose. In the context of subsea systems, these components are the subsystems and connectors that together achieve the mission. Fig 5 shows an example of a small subsea system. Within each subsystem, there are a number of components or items and it is to these that TRLs are applied.

The term 'critical technology element (CTE)' is used in association with TRLs. A technology element is critical if the system depends on its technological element to meet operational requirements. CTEs are new specific technologies on which a system depends to meet operational threshold requirements in development, production and operation. The assessment panel scores the level of technological maturity for each CTE by using TRLs.

A process known as the technology readiness assessment (TRA) is used to identify CTEs of a system. TRA is a systematic, evidence-based process that assesses the maturity of CTEs, though not every component is subjected to rigorous TRAs. TRA is not intended to assess the quality of the system architecture, design or integration, but only reveal

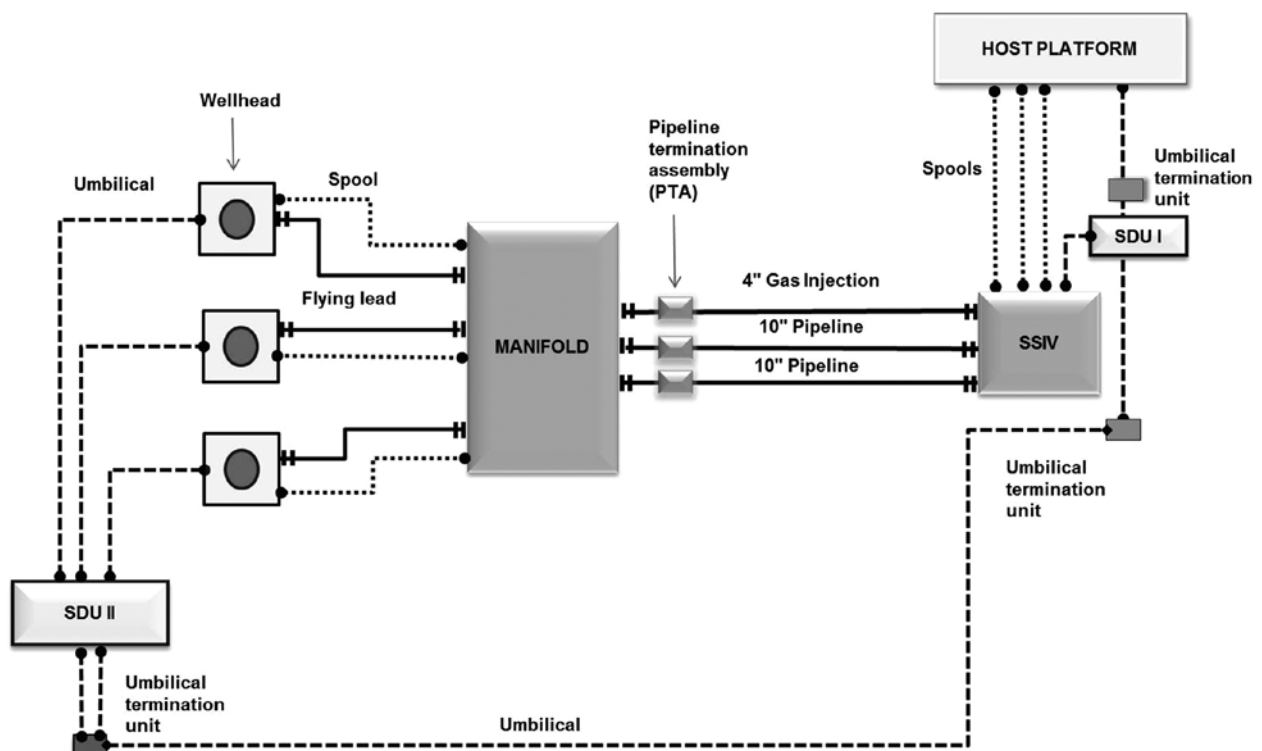

Fig 5: A typical subsea system used for illustrative purposes

the readiness of critical system components based on what has been accomplished to date.

In subsea practice, no subsystem, assemblies or (large) components are excluded from the assessment, thus all components are considered to be critical elements. The level of detail is decided by the assessor(s), with help from the subject expert. This suggests that the purpose of TRL in the subsea industry is to ensure the readiness of the components for insertion into the system. Thus, all items are represented in the system DSM.

Fig 6 shows a DSM for the entire system as shown in Fig 5, with simplifications made for illustrative purposes. These include grouping together a few similar components (e.g. flowlines and valves, piping, etc.) or not showing some connectors (e.g. connections of subsea distribution systems) for the sake of simplicity. This matrix can be much larger, though only important items should be included to avoid unnecessary complications. Once the system’s DSM (Fig 6) is complete, TRLs for each item can be assigned by following the procedure described in Table 7.

For this example, it is assumed that two interfacing components could be at a different TRL, but their IRLs are the same and equal to the least ready component (due to mutual dependency), hence yielding a symmetric matrix. In general, if two components have to come together to create a connection, there may be different degrees of integration readiness for each component and hence the matrix would not be symmetric. Symmetry assumption is not necessary for the success of the method.

Each row of the column ‘Average_IRL’ in Fig 6 is the arithmetic mean of all IRLs in that row, determined by summing up the IRLs of all interfaces across the row and dividing it by the number of interfaces, e.g. for the first row $(4 + 4 + 5)/3 = 4.33$. The next column gives the results of multiplication of the component’s TRL by the average of its IRLs; e.g. in row 1, $5 \times 4.33 = 21.67$. The next column gives the RMS for each subsystem. The square root of column 16 is given in column 17, giving a composite component readiness index. The composite readiness for the first subsystem (subsystem A in Fig 6, which is the flange on the bottom of the riser):

$$CR = \sqrt{\frac{21.67 + 16.00 + 16.00 + 20.}{4}} = 4.29 \quad (1)$$

Four in the denominator is the number of components of the first sub-system. The composite readiness levels for the remaining subsystems are estimated similarly and are entered in the last column in Fig 6.

Table 7: Assigning TRLs and IRLs for each element in DSM of Fig 6

| | |
|--------|--|
| Step 1 | Choose an item |
| Step 2 | Assignment. Ask the question: ‘What design stage is the equipment currently at?’ It should be recognised that for high TRLs and IRLs, the evidence for moving up the scale is environmentally dependent – the highest TRL only applies if the equipment is to be used in exactly the same operating environment and the same planned facility. |
| Step 3 | Evidence. Register the evidence used to provide the assessment. |
| Step 4 | If conditions for a given level are satisfied, then assume that level is achieved. If at least one condition for a given level is not satisfied, then assume that level is not achieved. |
| Step 5 | Repeat steps 1 to 4. Collect evidence for the remaining elements in the system DSM. |
| Step 6 | Calculate the SRL using TRL and IRL of all the elements using the method described in Appendix B. Using the SRL definition of Fig 2 determine the SRL and determine if it is on target. |

The composite readiness level is estimated in a similar manner. There are six subsystems where 6 is the number of subsystems making up a system (Fig 6):

$$SRL_{est} = \sqrt{\frac{(4.29)^2 + (4.74)^2 + (4.51)^2 + (4.56)^2 + (4.71)^2 + (4.74)^2 + (4.61)^2}{6}} = 4.57 \quad (2)$$

From a metric point of view SRL_{est} and SRL are meant to measure the same things on the same scale. However, SRL is defined (Table 3), while SRL_{est} is derived by aggregation of attributes of all components that may be at different levels of TRL and IRL. If all components mature simultaneously along the same path, then SRL_{est} reaches SRL.

The resulting estimated SRL is 4.57. Entering Table 2 with 4.57, indicates that the system must be at the manufacturing and installation stage. If the project schedule dictates a different level, then reasons must be sought.

This index informs the management when and where to intervene if the system readiness is lagging behind the schedules. The markers in each row identify which components require more management attention. A tightly controlled project ensures that TRL, IRL and SRL closely follow each other. The estimated system readiness index of 4.57 suggests that some components are not maturing within the desired time frame. In this hypothetical example, components with TRL or IRL lower than 4.57 need to be scrutinised.

8. Discussion

For a development to be successful, the technologies forming the core of the system need to be

evaluated, categorised and considered using measurable criteria that are common across the range of technologies. The TRL is commonly used to characterise and represent a single technology, but has been found to be insufficient when large combinations of technologies are integrated to form a system. To complement the TRL, the IRL method for representing the relationship between technologies was developed (Sauser et al., 2008, Yasserli, 2013). IRL measures the maturity level of the relationship between subsystems of a larger system. These two metrics were combined using an algebraic procedure to estimate the level of system readiness.

Technologies are not normally considered viable until they reach TRL 3. Technology candidates that are at TRL 3 then go through the assessment stages in TRLs 4 and 5, as well as a functional demonstration in a relevant environment at TRL 6. It is highly recommended that a given technology is at TRL 4 before being chosen for insertion in the final system. The technology level should be at TRL 4 by the define phase and in compliance with TRL 5 at the critical design review of the final system (Yasserli, 2014). Some of the reasons for adopting TRL methodology are collected and are listed in Table 8.

Table 8: Key points for using TRL methodology (from various sources)

For designers

- TRL is a measure of technical maturity – it is not an assessment of the technology.
 - TRL is an assessment of readiness, nothing more.
 - TRL does not indicate that the technology is right for the job.
 - Be pragmatic in assessment.
 - Use evidence (e.g. test, literature, peer review) not opinion in making judgment.
 - TRL is designed to measure progress and helps to mitigate against the technical risk.
 - It is important that assumptions regarding the environment and material are clearly understood.
 - Identify all the operational conditions.
 - Pay special attention to technology that requires adaptation.
 - A high TRL in another industry does not guarantee a high TRL in subsea.
 - Strictly adhere to the management of change.
-

For project and systems managers

- Provide a common language among the technology developers, engineers who will adopt/use the technology and other stakeholders.
 - TRLs, on their own, are not a measure of risk.
 - TRLs are not a proxy for risk, cost or duration.
 - Do not use TRLs as a tick box of progress. They only support the development plan.
 - TRLs do not indicate that the technology can be successfully developed.
 - TRLs of individual items do not indicate that the whole system will work together.
 - The integration and interfaces need to be assessed using IRL and SRL.
 - Technology at TRL 7 may still have room for improvement.
 - The technology will stay at TRL 8 unless a change occurs.
 - Reveal the gap between a technology's current readiness level and the readiness level needed for successful inclusion in the final product.
 - Identify at-risk technologies that need increased management attention or additional resources for technology development to initiate risk-reduction measures.
 - Increase transparency of critical decisions by identifying key technologies that have been demonstrated to work, or by highlighting still immature or unproven technologies that might result in high project risk.
-

For sanctioning authorities

- Subsea industry uses a stage-gated process for sanctioning projects, and TRLs should be a mandatory requirement of the acceptance criteria for a gate.
 - TRLs must be reviewed independently from the fabricator.
 - TRLs with caveats are not useful.
 - Only the sanctioning authority can accept a lower TRL at a stage-gate.
 - High TRLs are not necessarily 'good' and low TRLs 'bad'. The acceptable technical risk determines what is acceptable.
 - Any changes will alter the TRL – it can go down as well as up.
 - Make sure everyone is using the same definition and scale (common understanding).
-

For vendors

- Technologies used elsewhere may not be as easy to implement.
 - Technologies at a low TRL may move quickly to maturity, given the right environmental context and drive from the client and manufacturer.
 - Work with the client to understand the context and environment in which they intend to use the technology. Functional specifications will provide these details.
 - Create a development plan that explains what needs to be done.
-

9. Conclusions

This paper describes the experience gained in the application of the TRL method, by the author and others. The consensus is that TRLs alone do not give a complete picture of the readiness of a system, or the likely level of risk in adopting a particular technology. In developing a technology, the technology risk can be better managed through monitoring and control with the help of TRLs, IRL and SRL in combination with risk indicators. These metrics provide a common understanding of the status of a technology in its pathway to maturation, as well as a means of assessing and managing technical risks. They also give a snapshot of where a system is on the readiness scale at a particular moment in time. They do not give any indication about the difficulty, or even the possibility, of moving to a higher maturity level.

The cost, scheduling and effort required to transition from one level to the next are neither linear nor proportionate. Transitioning between TRLs within classification groups (i.e. concept validation (TRL 0 to 2), technology validation (TRL 3 to 5) and system validation (TRL 6 and 7)) is generally easier than transitioning between classification groups. It was also emphasised that these three scales should be used in the stage-gate decision process to determine the readiness of a project for the advancement to the next phase (e.g. from define phase to execute phase, see Yasseri, 2015b).

As with any management decision support tool, there are certain limitations.

Advantages include:

- provides a common understanding of technology status;
- helps with technical risk management;
- used for decision making for a project with stage-gate process; and used to make decisions concerning transition of technology.

Disadvantages include:

- more reporting and reviews;
- relatively new, takes time to influence the system; and
- systems engineering not addressed in early TRLs.

References

- American Petroleum Institute (API). (2009) API RP 17N: *Subsea production system reliability and technical risk management. Recommended Practice*. API: 99pp.
- Azizian N, Sarkani S and Mazzuchi T. (2009). A comprehensive review and analysis of maturity assessment approaches for improved decision support to achieve efficient defense acquisition. In: Proceedings of the World Congress on Engineering and Computer Science (WCECS), 20–22 October, San Francisco, USA. Available at: http://www.iaeng.org/publication/WCECS2009/WCECS2009_pp1150-1157.pdf. <last accessed 13 May 2016>.
- Azizian N, Mazzuchi T, Sarkani S and Rico DF. (2011). A framework for evaluating technology readiness, system quality, and program performance of U.S. DoD acquisitions. *Systems Engineering* **14**: 410–426.
- Bilbro JW. (2007). A suite of tools for technology assessment. Technology Maturity Conference: Multi-Dimensional Assessment of Technology Maturity, 11–13 September, Virginia Beach, USA. Available at: <http://www.dtic.mil/cgi-bin/GetTRDoc?AD=ADA507181>. <last accessed 13 May 2016>.
- Browning TR. (2001). Applying the design structure matrix to system decomposition and integration problems: a review and new directions. *IEEE Transactions on Engineering Management* **48**: 292–306.
- Browning TR and Eppinger SD. (2002). Modelling impacts of process architecture on cost and schedule risk in product development. *IEEE Transactions on Engineering Management* **49**: 428–442.
- Browning TR. (2016). Design structure matrix extensions and innovations: a survey and new opportunities. *IEEE Transactions on Engineering Management* **63**: 27–52.
- Chrisman NR. (1995). Beyond Stevens: a revised approach to measurement for geographic information. In: Proceedings of AUTO-CARTO 12, 27–29 February, North Carolina, USA. Available at: <http://mapcontext.com/autocarto/proceedings/auto-carto-12/pdf/beyond-stevens-a-revised-approach-to-measurement.pdf>. <last accessed 13 May 2016>.
- Dacus, CL. (2012). Improving acquisition outcomes through simple system technology readiness metrics, *Defense Acquisition Research Journal* **19**: 444–461. Available at: http://dau.dodlive.mil/files/2014/11/Dacus_ARJ64.pdf. <last accessed 13 May 2016>.
- Det Norske Veritas (DNV). (2011). DNV-RP-A203: *Qualification of New Technology. Recommended Practice*. DNV: 78pp.
- Eppinger SD and Browning TR. (2012). *Design structure matrix methods and applications*. Cambridge MA: MIT Press, 352pp.
- Eppinger SD, Joglekar NR, Olechowski A and Teo T. (2014). Improving the systems engineering process with multi-level analysis of interactions. *Artificial Intelligence for Engineering Design, Analysis and Manufacturing* **28**: 323–337.
- Kujawski E. (2010). The trouble with the System Readiness Level (SRL) index for managing the acquisition of defense systems. National Defense Industrial Association 13th Annual Systems Engineering Conference, 25–28 October, San Diego, USA. Available at: http://www.dtic.mil/ndia/2010systemengr/ThursdayTrack7_10745Kujawski.pdf. <last accessed 13 May 2016>.
- Lord FM. (1953). On the statistical treatment of football numbers. *American Psychologist* **8**: 750–751.
- McConkie E, Mazzuchi T, Sarkani S and Marchette D. (2013). Mathematical properties of system readiness levels. *Systems Engineering*, **16**: 391–400.
- Olechowski A, Eppinger SD and Joglekar N. (2015). Technology readiness levels at 40: a study of state-of-the-art use, challenges and opportunities. MIT Sloan Research Paper No. 5127–15. Available at: <http://ssrn.com/abstract=2588524>. <last accessed 13 May 2016>.
- Sausser BJ, Ramirez-Marquez JE, Henry D and DiMarzio D. (2008). A system maturity index for the systems engineering life cycle. *International Journal of Industrial and Systems Engineering* **3**: 673–691.

- Sausser BJ, Gove R, Forbes E and Ramirez-Marquez J. (2010). Integration maturity metrics: development of an integration readiness level. *Information Knowledge Systems Management* **9**: 17–46.
- Smith JD. (2005). An alternative to technology readiness levels for non-developmental item (NDI) software. In: Proceedings of the 38th Annual Hawaii International Conference on System Sciences, 3–6 January, Big Island Hawaii, USA. Available at: <https://www.computer.org/csdl/proceedings/hicss/2005/2268/09/22680315a.pdf>. <last accessed 13 May 2016>.
- Stevens SS. (1946). On the theory of scales of measurement. *Science, New Series* **103**: 677–680.
- Tetlay A and John P. (2010). Clarifying the concepts of system maturity, system readiness and capability readiness through case studies. In: Proceedings of the 8th Annual Conference on Systems Engineering Research, 17–19 March, New Jersey, USA. Available at: <https://core.ac.uk/download/files/23/139463.pdf>. <last accessed 13 May 2016>.
- Yasseri S. (2013). Subsea system readiness level assessment. *Underwater Technology* **31**: 77–92.
- Yasseri S. (2014). Application of system engineering to subsea development. *Underwater Technology* **32**: 93–109.
- Yasseri S. (2015a). Evidence based subsea engineering. *Underwater Technology* **32**: 231–244.
- Yasseri S. (2015b). Interface management of subsea field development. *Underwater Technology* **33**: 41–57.

Appendix A: Ordinal numbers

TRL is an ordinal scale. An ordinal scale only gives information about the rank order according to relevant quality. It does not give information concerning the differences between levels, hence it does not convey precise quantitative information. With an ordinal scale, we know the rank order, but we do not have an idea of the distance or interval between the rankings. The common use of Likert-type scales in behavioural research is an example of ordinal numbers usage. Although most psychological scales are probably ordinal, psychologists assume that they have equal intervals. Often people are asked on a scale of 1 to 5, to rate something. Here people are being shown a scale and being asked to use it.

Consider again grades for academic work, say E to A. Often such grades are also treated numerically, say as 1 to 5, and routinely universities calculate averages for students, courses, schools, etc. While it remains true that any mapping to numeric scores is arbitrary, it is considered generally acceptable, as long as it preserves the order.

We do not know anything about the intervals between the TRL ratings. Is the difference between 1 and 2 the same as that between 3 and 4? Does a rating of 4 really mean it is four times better than TRL at level 1? Performing an arithmetic operation on ordinal numbers involves the assumption that the differences between them are equal. There have been debates about what we can and cannot do with ordinal scales. One of the earliest and most influential papers on how we should classify the numbers comes from Stevens (1946) in his paper, ‘On the theory of scales of measurement’. He proposed four levels of measurements – nominal, ordinal, interval and ratio – and argued that only certain calculations are permissible with each type of data. In fact, he said that it is not possible to add and subtract, much less compute, a mean or standard deviation on anything less than interval data (Chrisman, 1995).

The rating scales are a research tool for some academic disciplines such as marketing, psychology and social sciences and it is hard to imagine how they would function without it. The famous statistician, Frederic M. Lord published a counter argument for Stevens’s classification (Lord, 1953), despite which, Stevens’s classification prevails in engineering and science.

Taking the arithmetic too far will certainly lead to unreasonable results. If TRL of equipment A is 2, and 4 for equipment B, this does not necessarily mean that equipment B is twice as ready as equipment A. Four is definitely twice two, but using TRL to compare two pieces of equipment is not really useful, since equipment B may stall in progress, while equipment A may progress easily to insertion stage.

The averaging process performed here is not intended to measure the level of required efforts, but to estimate the level of progress. Furthermore, the averaging is around the same rank. Although subsystems require different schedules and budgets to move from one level to another, they are pushed along the same timeline.

Appendix B: The root mean square

Each element within a subsystem has its own TRL and IRL. It can be assumed the TRL of the entire subsystem is equal to the TRL of a component with lowest maturity, and the same approach is taken to define the IRL of the subsystem. This approach simplifies the calculation, but introduces an error that ignores the higher TRL and IRL of other components. It was suggested to use a weighted average instead acknowledging efforts gone into maturing the subsystem.

Suppose an SPS is partitioned into M sub-system, and each of them has J independent components, $(X_j \quad j = 1, 2, \dots, J)$, as shown in Fig 6. TRL of each component (X_i) is noted in next to row X_i . The readiness level of component (X_i) to be integrated with the component (X_k) is shown by an X at the

intersection of column X_i with row X_k . Similarly, the readiness level for X_k to be integrated with X_i is shown in column X_k and row X_i . It is assumed the IRLs are the same, hence yielding a symmetric matrix. This assumption is not necessary, but it is generally the case.

Let TRL_j , $j = 1, 2, \dots, J$ be at the TRL level of X_j , $j = 1, 2, \dots, J$, respectively. Component X_j (row X_j) has interfaces with N_j components, and the IRLs are given by IRL_{jn} for a given $J = 1, 2, \dots, J$ and $n = 1, 2, \dots, N_j$.

The average of the integration readiness of X_j is given by:

$$(X_{j-}IRL)_{Ave} = \left(\frac{\sum_{n=1}^{N_j} IRL_{jn}}{N_j} \right),$$

for $j=1, \dots, J$, and for a given j , $n = 1, \dots, N_j$ (A1)

where N_j is the number of interfaces of X_j , J is the number of components and IRL_{jn} (for given j , $n = 1, \dots, N_j$) is the interface readiness as entered in row j .

The composite readiness (CR) of component X_j is given by:

$$X_{j-}CR = \sqrt{TRL_j \times (X_{j-}IRL)_{Ave}}, \text{ for } j=1, \dots, J \quad (A2)$$

The composite readiness of the subsystem M_i ($i=1, 2, \dots, M$) is given by:

$$M_{i-}CR = \sqrt{\frac{\sum_{j=1}^J (TRL_j \times (X_{j-}IRL)_{Ave})}{K}} \quad (A3)$$

where J is the number of components in M_i and K is the number of elements making up a subsystem.

Equations for the composite readiness level of the system are similar. From this, it is clear that the RMS value is always greater than or equal to the average, because the RMS includes the 'error'/square deviation as well.