



2nd International Conference on Sustainable Energy and Resource Use in Food Chains, ICSEF
2018, 17-19 October 2019, Paphos, Cyprus

Design of a high-temperature heat to power conversion facility for testing supercritical CO₂ equipment and packaged power units

Giuseppe Bianchi^{a,*}, Samira S. Saravi^a, Romain Loeb^b, Konstantinos M. Tsamos^a,
Matteo Marchionni^a, Arthur Leroux^b, Savvas A. Tassou^a

^a*Brunel University London, Institute of Energy Futures, Centre for Sustainable Energy use in Food chains (CSEF),
Uxbridge, UB8 3PH, United Kingdom*

^b*Enogia, SAS, 19 avenue Paul Heroult, Marseille 13015, France*

Abstract

This paper addresses the need of bridging between fundamental energy research and industrial exploitation of technologies by presenting a state of the art experimental facility to investigate pilot heat exchangers and plants dealing with high temperature waste heat recovery and conversion. The facility comprises a 830 kW process air heater with an exhaust mass flow rate of 1.0 kg/s at 70 mbar_g and maximum temperature of 780 °C. The heater has a 2.0 m long test section for the installation and characterization of waste heat recovery heat exchangers. The heat sink is a 500 kW water dry cooler with full control of flow rate and temperature of the cooling stream. The high-temperature heat to power conversion facility hosts a 50 kWe power conversion unit based on the simple recuperated Joule-Brayton cycle with supercritical CO₂ (sCO₂) as working fluid. The packaged, plug and play sCO₂ system utilizes a single-shaft Compressor-Generator-Turbine unit. The paper discusses the main design features of the test facility as well as operation and safety considerations.

© 2019 The Authors. Published by Elsevier Ltd.

This is an open access article under the CC BY-NC-ND license (<https://creativecommons.org/licenses/by-nc-nd/4.0/>)

Selection and peer-review under responsibility of the 2nd International Conference on Sustainable Energy and Resource Use in Food Chains, ICSEF2018

Keywords: supercritical CO₂; waste heat recovery; printed circuit heat exchanger; micro-tube heat exchanger; turbomachinery

* Corresponding author. Tel.: +44-1895-267707; fax: +44-1895-269777.

E-mail address: giuseppe.bianchi@brunel.ac.uk

1. Introduction

High-grade thermal energy recovery or conversion from waste heat sources is a challenging but attractive opportunity for industry given the high-exergy content, low pay back periods, and consequently, favourable financial returns. With reference to the segmentation proposed by Forman [1], exhausts and effluents at temperatures beyond 300°C are typical in the iron and steel, nonmetallic minerals (glass, cement), nonferrous materials (aluminum) industrial sectors, and account for potential energy recovery of up to 275 TWh in the European Union [2,3] and 3367 TWh worldwide [1].

Despite the environmental benefits, the main barrier to the installation of high-grade waste heat recovery technologies is the economic feasibility of the investment. In fact, the harsh operating conditions call for very high-specifications and bespoke engineering solutions that translate to significant capital expenditures (CAPEX) and reduced returns on investment.

Among the technologies currently being investigated, supercritical CO₂ (sCO₂) heat to power generation may be a disruptor for high temperature applications. In fact, the high operating pressures in sCO₂ devices lead to compact equipment with the potential to reduce capital costs. Moreover, from a thermodynamic perspective, Joule-Brayton cycles benefit from higher energy and exergy efficiency than conventional bottoming thermodynamic cycles such as the Organic or steam Rankine Cycles [4,5]. These facts can translate to greater savings during the operational lifetime of sCO₂ plants, leading to higher return on investment.

Present research on sCO₂ spans from next nuclear and fossil fuel power generation (500 to 1,000 MWe) [6–9], modular nuclear power generation (300 MWe) [10–12], solar thermal power generation (10 to 100 MWe) [13–17], shipboard propulsion, geothermal, oxy-combustion (1 to 100 MWe) [18–23], and industrial scale waste heat recovery (1 to 10 MWe) [24–26]. The technical feasibility of such systems has been so far assessed mostly at theoretical level and it has been focused on cycle analyses of large power scale sCO₂ systems for power generation applications.

Experimental sCO₂ facilities have been increasing in terms of number and potential. As reported in [27], most of the integral test loops are based on simple recuperated cycles [28]. Target pressure ratios range from 1.4 to 2.9 while calculated efficiencies range from 14.7% to 31.5%.

The activities presented in this paper are focused on the development of high-Technology Readiness Level (TRL) small-scale sCO₂ systems in the power range around 50 kWe. Reasons for focusing on this segment relate to the widespread nature of the waste heat as well as to the preliminary feasibility studies reported in [29,30]. The novel aspects presented in this work are not only the design challenges and lessons learned in the development of a packaged, plug&play sCO₂ heat to power conversion systems but also relate to the development of a state of the art facility for high-temperature equipment testing at pilot scale.

2. High Temperature Heat To power Conversion facility (HT2C)

The High Temperature Heat To power Conversion facility (HT2C) at Brunel University London provides the capabilities for testing equipment and systems at pilot scale and addresses the technological gap which commonly exists during the scaling up of the technologies from fundamental research to mass production. An overview of the facility and its communication layout is shown in Figure 1 with reference to a configuration for sCO₂ heat to power conversion testing. Details on the sCO₂ unit are reported in Section 3.

The heat source of the HT2C is an 830kW gas fired process air heater whose main features are listed in Table 1 while the Process and Instrumentation Diagram (P&ID) is detailed in Figure 2(a). The high flexibility of operation is the key feature of the heat source and the whole facility. Inlet conditions to the high temperature test section are controlled with a proprietary system that relies on primary fan speed and flow rate of flue gas as control signals while temperature downstream the process air heater and airflow rate are used for control feedback. A similar control architecture is repeated for the low temperature test section. The high temperature test section has a maximum length of 2000 mm while the cross-section is 500x500 mm with 200mm alkaline earth silicate wool insulation.

The heat sink of the H2TC facility is a 500 kW dry cooler system. Its features are listed in Table 2 while the P&ID is shown in Figure 2(b). The dry cooler employs variable speed drives for the pump and the fans. A noteworthy feature of the chosen layout is the presence of an electric heater to warm-up the auxiliary fluid in the cooling loop to be used during the startup phase of the sCO₂ tests.

The monitoring and control of the whole facility is centralized. A supervisory controller based on the IEC61499 standard allows the other PLC controllers of the subsystems to communicate via the Modbus protocol. High-level information can also be accessible online.

3. Packaged sCO₂ heat to power unit

In the current study, the HT2C facility has been set up to host the demonstration of a 50 kWe heat to power unit based on a supercritical CO₂ Joule-Brayton cycle. The design conditions of the loop are summarized in Table 3 and result from a constrained optimization study available in [31]. In particular, the sCO₂ system is based on a simple recuperated cycle with a pressure ratio of 1.7 and maximum operating temperature of 400°C. The recuperator is a commercial printed circuit heat exchanger and the CO₂ cooler is a plate heat exchanger. The heater is a novel micro-tube heat exchanger that will be installed in the duct shown in Figure 1.

Table 3. Design conditions of the sCO₂ power unit.

	min	max
Pressure [bar]	75	127.5
Temperature [°C]	35	400
Mass flow rate [kg/s]	2.25	

The CAD design of the sCO₂ system is reported in Figure 3. Except for the CO₂ heater, all the components have been enclosed in a 20ft standard shipping container. Pipework is in SS316 while flanged connections are of ring joint type (RTJ). This arrangement fulfills the needs of a packaged solution which is required for a high-TRL compliancy of the developed unit. In fact, the compact solution is also a plug&play one; the connections required are inlet and outlet pipes for heat source and sink, a compressed air supply and electrical connections to the grid. An additional requirement that the sCO₂ unit will fulfil is the compliancy to the Pressure Equipment Directive (PED) (2014/68/EU).

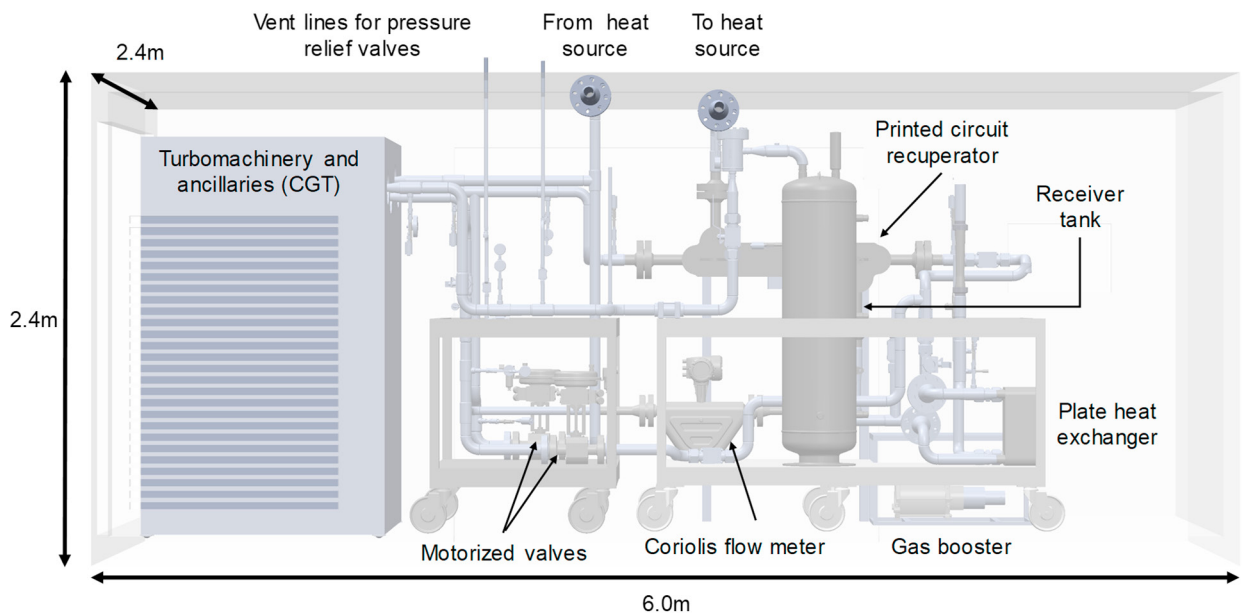

Fig. 3. High-temperature sCO₂ heat to power conversion system packaged in a standard 20ft shipping container

The instrumentation selected to characterize the performance of components and the whole sCO₂ system is shown in the P&ID of Figure 4. In particular, to assess the performance of heat exchangers, a high-accuracy piezo resistive

pressure transducer upstream of the device is coupled with a differential pressure transducer across the heat exchanger. As for the the temperature transducers, 3-wire resistance temperature detectors (RTDs) type PT100 are considered throughout the CO₂ loop except at the measurement locations across the compressor where 4-wire RTDs are considered. Flue gas temperatures are measured with K-type thermocouples. A Coriolis gas flow meter is installed downstream of the compressor by-pass. Assuming the design conditions to be measured parameters, based on the transducers accuracies summarized in Table 4, Table 5 reports the expected uncertainty propagation of the key performance parameters. From this analysis, it can be concluded that the quantity that mostly affects the measurement uncertainty is the pressure at the inlet of the compressor.

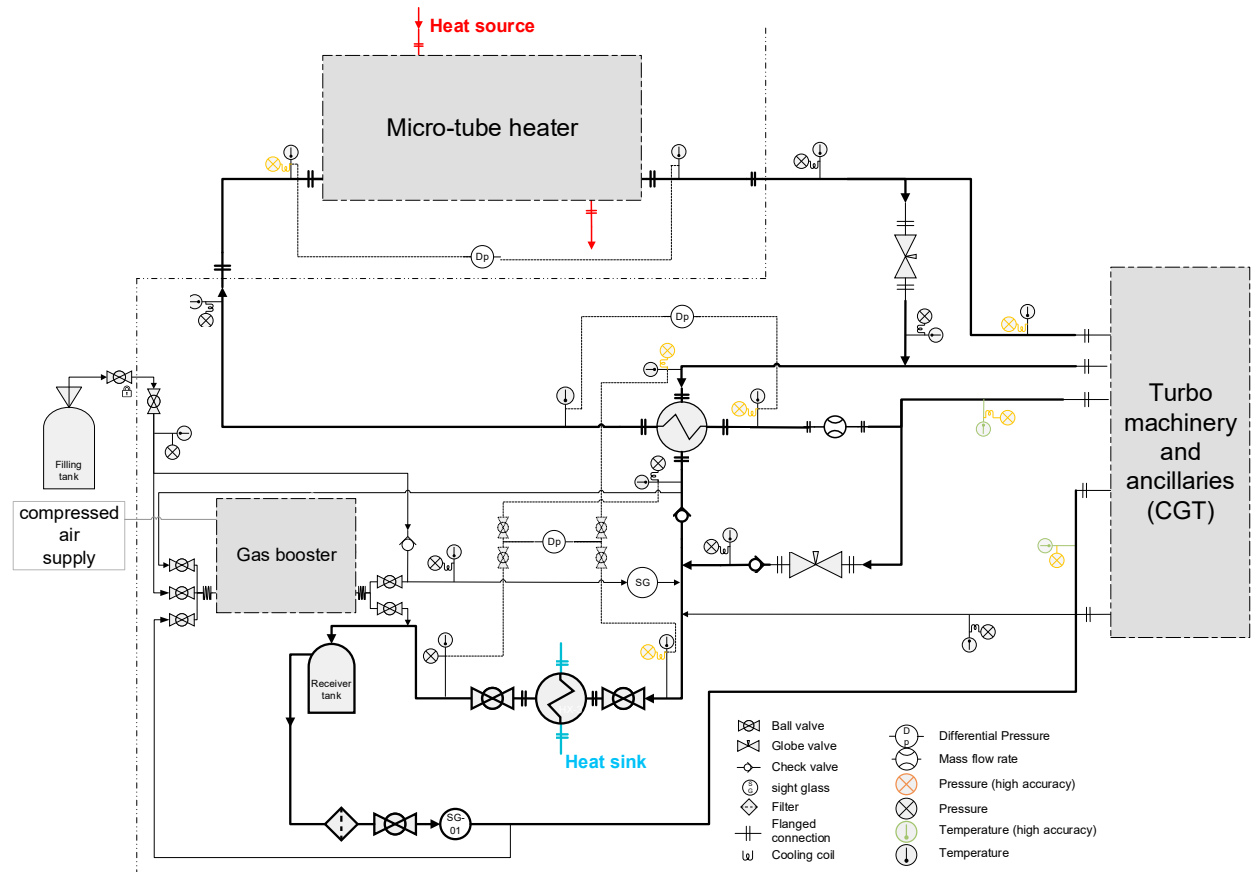

Fig. 4. Simplified P&ID of the sCO₂ heat to power conversion system shown in Figure 3

Table 4. Summary of transducers accuracies.

Accuracy	high	standard
High pressure transducers	0.17 bar	0.52 bar
Low pressure transducers	0.10 bar	0.34 bar
Temperature transducers (RTD)	0.03K	0.06K
Differential pressure transducer	1.9mbar	
Mass flow rate (Coriolis)	0.35% of measured value	

Table 5. Estimated measurement uncertainty at design conditions.

Uncertainty	Power	Efficiency
Compressor	2.66%	3.32%
Turbine	0.43%	0.47%
Heater	0.36%	
Recuperator (cold/hot side)	0.36%/0.35%	
Cooler	0.61%	

The envisaged startup sequence has been discussed in [31] but is also summarized here for the benefit of the readers. A gas booster instead of a more expensive CO₂ pump has been considered not only for ease of charging the CO₂ circuit

but also to allow a 5-10% of nominal flow rate during startup. Low temperature heat is provided to ensure that CO₂ is not in liquid phase before starting the compressor.

Two electric actuated globe valves will be installed in the compressor and turbine by-pass branches as suggested by the research group of the US Naval Nuclear Laboratory [32,33]. In a previous release of the design [31], a third valve upstream of the turbine was also considered to be able to set the inlet pressure during the tests. However, besides the additional budget implications, since globe valves lead to a noticeable pressure drop even when fully opened, the valve upstream of the turbine was eventually discarded to avoid adverse impacts on overall system performance.

4. Compressor, Generator and Turbine (CGT) unit manufacturing and assembly

The Compressor, Generator and Turbine unit, herein referred as the CGT, is the core of the sCO₂ heat to power conversion system. Its design involved diverse expertise and it is reported in more detail in [31,34]. The results of the aerodynamic design are summarized in Table 6. Figure 5, shows the unshrouded compressor and turbine impellers, which were machined from material block and milled to desired shapes derived from the aerodynamic design.

Table 6. Summary of the aerodynamic design.

		Compressor	Turbine
Rotor	Diameter	55 mm	72 mm
	No. of blades	7	14
Nozzle	No. of blades	11	17
	Isentropic efficiency (total-static)	76%	70%

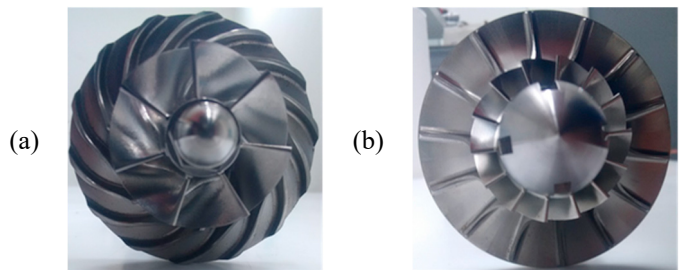

Fig. 5. Impellers: (a) compressor; (b) turbine

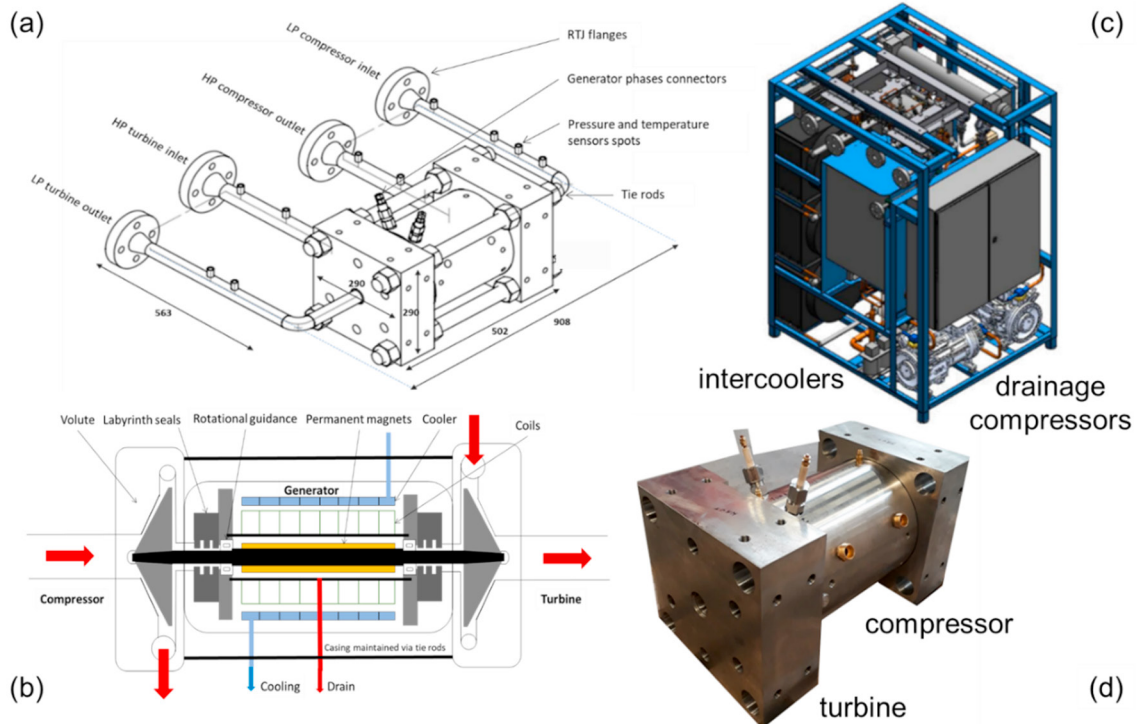

Fig. 6. CGT unit: (a) turbomachinery and generator dimensions and interfaces, (b) operating principle, (c) turbomachinery and ancillaries (d) picture of the manufactured and assembled turbomachinery and generator unit

Figure 6(a), shows the full CGT assembly whose overall dimensions are 290x290x502 mm (WxHxL). An emergency pneumatic valve has also been considered between the compressor outlet and compressor inlet. The purpose of this valve is to shortcut the compressor and, consequently, prevent any high pressure flow going to the turbine in case of faults in the controls or grid failures.

As shown in Figure 6(b), the CGT is rather complex due to the CO₂ and ancillary loops required for lubrication, drainage and cooling [31]. Among them, two piston compressors with plate intercoolers have been considered to inject the drainage, after oil separation, back to the main loop. The choice of a dual-stage intercooled compression was to limit the drainage recovery temperature at a value suitable for refrigeration compressors (<120°C). These ancillaries are shown in Figure 6(c) together with the whole CGT unit.

5. CONCLUSIONS AND FUTURE WORK

Energy recovery from high temperature sources has a wide application potential ranging from the steel industry to nuclear and concentrated solar power. Nonetheless, the economic feasibility of high temperature heat recovery or heat to power conversions is often hindered by the high capital expenditure required for the design and manufacture of high-specification bespoke equipment. In order to promote the transition towards higher technology readiness levels of fundamental research concepts and technologies, this paper has presented the design and layout of a state of the art high-temperature facility suitable for testing heat recovery and heat to power conversion equipment at pilot scale. The facility comprises a 830kW gas fired process air heater and a 500 kW water dry cooler as heat sources and sink respectively. There are two test sections for heat exchangers testing at low and high temperatures and a centralized control and monitoring system based on Modbus protocol to supervise the whole facility.

In this work, the facility serves to provide heat gain and rejection to a 50kWe supercritical CO₂ unit based on a simple recuperated Joule-Brayton cycle. The core of the sCO₂ unit is a compressor-generator-turbine unit (CGT) composed of a single shaft turbomachinery. The experimental rig is packaged in a 20ft container and will be CE marked according to the Pressure Equipment Directive (PED) (2014/68/EU). A preliminary uncertainty analysis showed a maximum uncertainty of 2.3% on the compressor isentropic efficiency mostly due to the inlet pressure measurement.

Acknowledgements

The research presented in this paper has received funding from the European Union's Horizon 2020 research and innovation programme under grant agreement No. 680599. Aspects of the work are also funded by: i) the Centre for Sustainable Energy Use in Food Chains (CSEF) and, ii) the Engineering and Physical Sciences Research Council (EPSRC) funded project 'Optimising Energy Management in Industry-OPTMIN' Grant No: EP/P04636/1. CSEF is an End Use Energy Demand Centre funded by the Research Councils UK, Grant No: EP/K011820/1. Further information and data used in the paper can be obtained by contacting the corresponding author directly.

References

- [1] Forman C, Muritala IK, Pardemann R, Meyer B. Estimating the global waste heat potential. *Renewable and Sustainable Energy Reviews* 2016;57:1568–79. doi:10.1016/J.RSER.2015.12.192.
- [2] Papapetrou M, Kosmadakis G, Cipollina A, La Commare U, Micale G. Industrial waste heat: Estimation of the technically available resource in the EU per industrial sector, temperature level and country. *Applied Thermal Engineering* 2018;138:207–16. doi:10.1016/J.APPLTHERMALENG.2018.04.043.
- [3] Panayiotou GP, Georgiou G, Aresti L, Argyrou M, Agathokleous R, Tsamos KM, et al. Preliminary assessment of waste heat potential in major European industries. *Energy Procedia* 2017;123:335–45. doi:10.1016/J.EGYPRO.2017.07.263.
- [4] Persichilli M, Kacludis A, Zdankiewicz E. *Supercritical CO₂ Power Cycle Developments and Commercialization: Why sCO₂ can Displace Steam Ste. Power-Gen India & 2012.*
- [5] Huck P, Freund S, Lehar M, Peter M. The 5 th International Symposium-Supercritical CO₂ Power Cycles Performance comparison of supercritical CO₂ versus steam bottoming cycles for gas turbine combined cycle applications. n.d.
- [6] Ahn Y, Bae SJ, Kim M, Cho K, Baik S, Lee I, et al. Cycle layout studies of S-CO₂ cycle for the next generation nuclear system application. n.d.
- [7] Moiseyev A, Siemicki JJ. Investigation of alternative layouts for the supercritical carbon dioxide Brayton cycle for a sodium-cooled fast reactor. *Nuclear Engineering and Design* 2009;239:1362–71. doi:10.1016/j.nucengdes.2009.03.017.

- [8] Ahn Y, Bae SJ, Kim M, Cho SK, Baik S, Lee JI, et al. Review of supercritical CO₂ power cycle technology and current status of research and development. *Nuclear Engineering and Technology* 2015;47:647–61. doi:10.1016/j.net.2015.06.009.
- [9] Weiland NT, White CW. Techno-economic analysis of an integrated gasification direct-fired supercritical CO₂ power cycle. *Fuel* 2018;212:613–25. doi:10.1016/j.fuel.2017.10.022.
- [10] Dostal V, Driscoll MJ, Hejzlar P, Wang Y. *Supercritical CO₂. Volume 7: Turbo Expo 2004, ASME; 2004, p. 683–92. doi:10.1115/GT2004-54242.*
- [11] Moisseytsev A, Sienicki JJ. Recent Developments in S-Co₂ Cycle Dynamic Modeling and Analysis At Anl. *The 4th International Symposium - Supercritical CO₂ Power Cycles* 2013;53:1689–99. doi:10.1017/CBO9781107415324.004.
- [12] Kim Y, Hartanto D, Yu H. Neutronics optimization and characterization of a long-life SCO₂-cooled micro modular reactor. *International Journal of Energy Research* 2017;41:976–84. doi:10.1002/er.3686.
- [13] Iverson BD, Conboy TM, Pasch JJ, Kruienza AM. Supercritical CO₂ Brayton cycles for solar-thermal energy. *Applied Energy* 2013;111:957–70. doi:10.1016/J.APENERGY.2013.06.020.
- [14] Silva-Pérez MA. Solar power towers using supercritical CO₂ and supercritical steam cycles, and decoupled combined cycles. *Advances in Concentrating Solar Thermal Research and Technology* 2017;383–402. doi:10.1016/B978-0-08-100516-3.00017-4.
- [15] Singh R, Rowlands AS, Miller SA. Effects of relative volume-ratios on dynamic performance of a direct-heated supercritical carbon-dioxide closed Brayton cycle in a solar-thermal power plant. *Energy* 2013;55:1025–32. doi:10.1016/j.energy.2013.03.049.
- [16] Binotti M, Astolfi M, Campanari S, Manzolini G, Silva P. Preliminary Assessment of sCO₂ Power Cycles for Application to CSP Solar Tower Plants. *Energy Procedia* 2017;105:1116–22. doi:10.1016/J.EGYPRO.2017.03.475.
- [17] Kalra C, Sevincer E, Brun K, Hofer D. Development of high efficiency hot gas turbo-expander for optimized csp supercritical CO₂ power block operation. *-Supercritical CO₂ Power ...* 2014.
- [18] Allam R, Martin S, Forrest B, Fetvedt J, Lu X, Freed D, et al. Demonstration of the Allam Cycle: An Update on the Development Status of a High Efficiency Supercritical Carbon Dioxide Power Process Employing Full Carbon Capture. *Energy Procedia* 2017;114:5948–66. doi:10.1016/J.EGYPRO.2017.03.1731.
- [19] McClung A, Brun K, Delimont J. Comparison of Supercritical Carbon Dioxide Cycles for Oxy-Combustion. *Volume 9: Oil and Gas Applications; Supercritical CO₂ Power Cycles; Wind Energy, ASME; 2015, p. V009T36A006. doi:10.1115/GT2015-42523.*
- [20] Levy EK, Wang X, Pan C, Romero CE, Maya CR. Use of hot supercritical CO₂ produced from a geothermal reservoir to generate electric power in a gas turbine power generation system. *Journal of CO₂ Utilization* 2018;23:20–8. doi:10.1016/J.JCOU.2017.11.001.
- [21] McClung A, Brun K, Chordia L. Technical and economic evaluation of supercritical oxy-combustion for power generation. *Supercritical CO₂ Power ...* 2014.
- [22] Manjunath K, Sharma OP, Tyagi SK, Kaushik SC. Thermodynamic analysis of a supercritical/transcritical CO₂ based waste heat recovery cycle for shipboard power and cooling applications. *Energy Conversion and Management* 2018;155:262–75. doi:10.1016/j.enconman.2017.10.097.
- [23] Sharma OP, Kaushik SC, Manjunath K. Thermodynamic analysis and optimization of a supercritical CO₂ regenerative recompression Brayton cycle coupled with a marine gas turbine for shipboard waste heat recovery. *Thermal Science and Engineering Progress* 2017;3:62–74. doi:10.1016/j.tsep.2017.06.004.
- [24] Kim MS, Ahn Y, Kim B, Lee JI. Study on the supercritical CO₂ power cycles for landfill gas firing gas turbine bottoming cycle. *Energy* 2016;111:893–909. doi:10.1016/J.ENERGY.2016.06.014.
- [25] Kauludis A, Lyons S, Nadav D, Zdankiewicz E. Waste Heat to Power (WH2P) Applications Using a Supercritical CO₂-Based Power Cycle am. 2012.
- [26] Mondal S, De S. CO₂ based power cycle with multi-stage compression and intercooling for low temperature waste heat recovery. *Energy* 2015;90:1132–43. doi:10.1016/j.energy.2015.06.060.
- [27] Vojacek A, Hacks A, Johannes J, Melichar T, Frybort O, Hájek P. Challenges in supercritical CO₂ power cycle technology and first operational experience at CVR 2018. doi:10.17185/dupublico/46075.
- [28] Brun K, Friedman P, Dennis R. *Fundamentals and applications of supercritical carbon dioxide (sCO₂) based power cycles. Woodhead Publishing an imprint of Elsevier; 2017.*
- [29] Marchionni M, Bianchi G, Karvountzis-Kontakiotis A, Pesiridis A, Tassou SA. Dynamic modeling and optimization of an ORC unit equipped with plate heat exchangers and turbomachines. *Energy Procedia* 2017;129:224–31. doi:10.1016/J.EGYPRO.2017.09.146.
- [30] Marchionni M, Bianchi G, Tassou SA. Techno-economic assessment of Joule-Brayton cycle architectures for heat to power conversion from high-grade heat sources using CO₂ in the supercritical state. *Energy* 2018;148:1140–52. doi:10.1016/J.ENERGY.2018.02.005.
- [31] De Miol M, Bianchi G, Henry G, Holaind N, Tassou SA, Leroux A. Design of a single-shaft compressor, generator, turbine for small-scale supercritical CO₂ systems for waste heat to power conversion applications. *2nd European sCO₂ Conference 2018* 2018. doi:10.17185/DUEPUBLICO/46086.
- [32] Clementoni EM, King MA, Cox TL. INITIAL TRANSIENT POWER OPERATION OF A SUPERCRITICAL CARBON DIOXIDE BRAYTON CYCLE WITH THERMAL-HYDRAULIC CONTROL. n.d.
- [33] Clementoni EM, Cox TL, King MA, Rahner KD. Transient Power Operation of a Supercritical Carbon Dioxide Brayton Cycle. *Volume 9: Oil and Gas Applications; Supercritical CO₂ Power Cycles; Wind Energy, ASME; 2017, p. V009T38A001. doi:10.1115/GT2017-63056.*
- [34] Holaind N, De Miol M, Saravi SS, Tassou SA, Leroux A, Jouhara H. Design of radial turbomachinery for supercritical CO₂ systems using theoretical and numerical CFD methodologies. *Energy Procedia* 2017;123:313–20. doi:10.1016/J.EGYPRO.2017.07.256.