

NO Abatement using Microwave Micro Plasma Generated using Granular Activated Carbon

N Manivannan^{1,2}, G Agozzino^{1,3}, W Balachandran^{1,2}, M Abbod¹ and D Brennen¹ and F Di Natale³

¹Centre for Electronic Systems Research

²Institutes of Environment, Health and Societies
College of Engineering, Design and Physical Sciences
Brunel University, London UB8 3PH

³Department of Chemical Engineering, Università di Napoli Federico II, Dip. di Ingegneria Chimica, dei Materiali della Produzione Industriale, Naples, Italy

Abstract- *Abatement of NO using microwave micro-plasma is presented in this paper. The micro-plasma is generated using granular activated carbon (GAC) particles of size (size 2-3mm) in loosely fluidised bed in microwave filed operated at 2.45GHz. A single mode microwave cavity reactor (SMMCR) was constructed and microwave was injected through another slotted waveguide in a sandwiched manner. COMSOL Multiphysics software was used to investigate the microwave electric field and the power density within the SMMCR. Gas mixture of air and 500 ppm NO (in N₂) at the flow rate of 2 l/min was passed through a quartz tube centered within SMMCR while the supplied microwave power was very low 10-80 W and NO reduction was greater than 98%. The mass of GAC used for generating the plasma was 5g. When air is mixed with NO (in N₂), the efficiency of NOx reduction achieved vary greatly with respect to the supplied microwave energy and behavior has become complex and is not predictable. The gas analyzer (testo 350) was used to measure the gas (NO, NO₂, CO and O₂) concentration and temperature.*

Key words: Non-Thermal plasma, NO_x abatement, Micro plasma, Microwave plasma, Granular activated carbon

I. INTRODUCTION

Marine diesel engine flue contains toxic gases such as NO_x (NO+NO₂) and SO_x (SO₂) which are harmful to environment and health [1, 2]. Marine industry is responsible for more than 15% of the world toxic gas emission and its impact can not only affect the

coastal area but also extends to large portion of in-land. Treating these gases before releasing into air is not only vital but also regulated by International Maritime Organization (IMO) [3, 4]. The current state-of-the-art of NO_x and SO_x removal in marine exhaust gas requires two separate units which are space ineffective and cost ineffective [3]. Even though their removal efficiency of SO_x is very high (>90%), NO_x is relatively low (~70%) which needs to be improved to comply with the requirements set by IMO. Furthermore, current NO_x removal systems require urea injection and produce ammonia, which requires large storage space and also carry the risk of ammonia leakage.

Non-Thermal Plasma (NTP) has been successfully employed in many land-based power plants to control NO_x and SO_x from high flow rate exhaust emission [5, 6]. These installations use electron beam and microwave to create non-thermal plasma and works really well in such applications, where space and power consumption are not significant issues. When this technology is to be implemented on a ship, the space and power consumption is a major concern and hence requires an alternative way of producing non-thermal plasma.

In this paper, a new method of producing NTP is introduced using only microwave energy. A single mode microwave cavity (SMMC) was designed in which microwave energy is injected through number of slots on a specially designed waveguide. COMSOL multi-physics software was used to compute the electric field within the microwave cavity. Granular activated carbon was used to produce micro-plasma within the single mode waveguide. Due to non-uniform nature of GAC surface and the fact carbon is good electrical conductor; it will create local regions with high electric field, in which local plasma will be generated. This is referred as micro-plasma.

Section 2 presents the methodology of the abatement system and also explains the complete experimental set-up. The FEM modelling work is given in Section 3 and results from the experiments are presented and discussed in Section 4. Finally conclusion is drawn in Section 5.

II. METHODOLOGY AND EXPERIMENTAL SET-UP

The gas flow diagram of the abatement system is shown in Fig. 1. As shown two gas cylinders (Air and NO balanced in N₂) are used as the test gas and their flow was controlled by flow meters. Gases from both cylinders are mixed before feeding into the SMMC. In the SMMC a quartz tube (internal diameter of 18 mm) is used to locate granular activate carbon and to guide the gas through for the abatement. The quartz tube is transparent to microwave and also able to withstand high temperature. The penetration depth (defined as the distance in which the electric field drops to 1/e) at room temperature for quartz tube for microwave filed at 2.45GHz frequency is 160km, whereas for water, it is only 1.4 cm. The melting point of quartz tube is around 17000 C. The activated carbon used is 1.4 to 2 mm in size and has high surface area (>1000 m²/g).

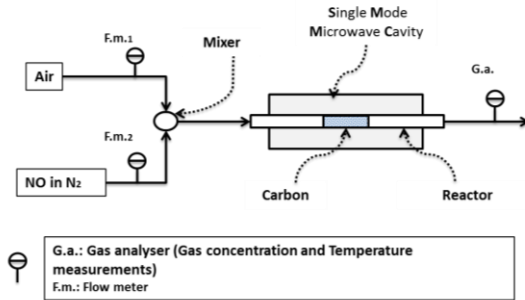
Fig. 1: Gas flow diagram of the NO_x abatement system

The experimental set-up is shown in Fig. 2, which shows the single mode cavity with a quartz tube and a slotted waveguide. Microwave energy is supplied from a magnetron operating at 2.5 GHz via a 3-stub tuner to the slotted waveguide, which, in turn, transmit the microwave energy into the single mode cavity where NTP is generated. Activated carbon is placed in the quartz tube. The mixture of NO + N₂ + Air from the gas bottles is supplied to the quartz tube in which the gas is treated with the micro plasma generated by the electric field within the activated carbon particles. Reflected microwave power is diverted into a water load. Testo 350, which is portable gas analyzer based on chemiluminescent sensors, was used to measure the gas concentration (NO, NO₂, CO, O₂) and temperature of the gas at the outlet of the SMMC.

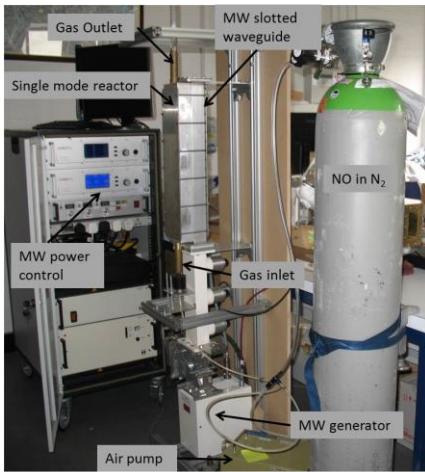

(a)



(b)



(c)

Fig. 2: Experimental set-up (a) complete set-up (b) Single mode waveguide with a quartz tube (c) Slotted waveguide

III. FEM MODELLING

Understanding the electric field pattern within the SMMC is essential to understand the plasma density within the cavity. Higher the electric field higher the plasma production and hence higher the electron density. Electrons in gas molecules gain energy and if they gained sufficient energy then they break away from their parent atoms. The broken away electrons gains further energy and move quicker in the electric field and can collide with gas molecules and disassociate more electrons from their parent electrons. These chain reactions will form plasma, which consists of ions, radicals, and excited molecules, which are more reactive than ordinary gas molecules, hence can allow more specialized reactions, which would otherwise not happen.

COMSOL multi-physics was used to study the electric field within the SMMC and following equations are solved.

$$\nabla \times \mu_r^{-1}(\nabla \times \mathbf{E}) - K_0^2 \left(\epsilon_r - \frac{j\sigma}{\omega\epsilon_0} \right) \mathbf{E} = 0 \quad (1)$$

Where μ_r - permeability of the medium, ϵ_0 - permittivity of the medium, \mathbf{E} - electric field vector, σ - density of the medium, K_0 - wave number. Walls of the wave guide were assumed to be perfect conductors and hence the following boundary condition was applied:

$$\mathbf{n} \times \mathbf{E} = 0 \quad (2)$$

where \mathbf{n} - normal vector to the walls.

Calculated electric field (absolute) is shown in Fig. 3. These results were obtained when the injected microwave power into the slotted waveguide was set to 600W. It is clear from these figures that high intensity electric field is seen near the first slot (bottom one) and it decays exponentially towards the top of the SMMC. The period of the high electric field region (half the wave length of the waveguide) is a function of SMMC dimensions and the wavelength of the microwave and can be calculated using the following equation.

$$\lambda_g = \frac{\lambda_0}{\sqrt{1 - \left(\frac{\lambda_0}{2a}\right)^2}} \quad (3)$$

λ_0 = wavelength of microwave (122mm)

a = length of the rectangular cross section (98 mm)

For the waveguide used in the experimental set-up, λ_g is calculated to be 55.9 mm; this can be confirmed in the results shown in Fig. 3b.

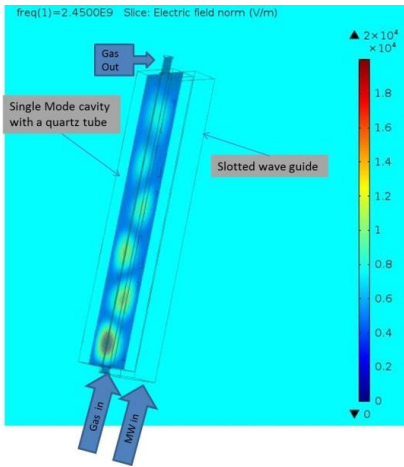

(a)

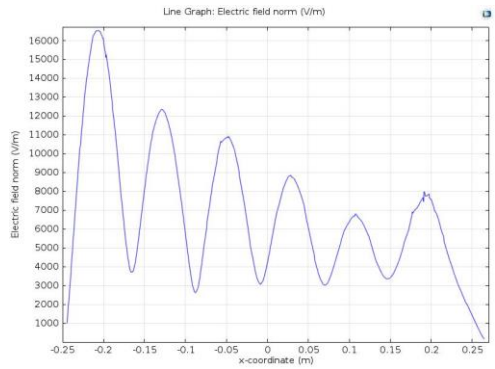

(a)

Fig. 3: Electric field within the SMMC when applied microwave is 600W (a) plane middle of the SMMC (b) line scan in the middle of the plane which is shown in (a)

IV. EXPERIMENTAL RESULTS AND DISCUSSION

Two test gas mixtures were used in this work. The first one is to use NO balanced in N_2 in the absence of O_2 , hence the abatement is a reduction process where NO would be reduced to O_2 and N_2 . In one of the previous work reported by Kuwahara et al. [7], the benefits of the oxygen-less system were explained. In that work, the NOx abatement was reported to be 65%. They used adsorption on NO onto Cu impregnated magnesium oxide (MnOx–CuO) and desorbed by purging N_2 , which then treated using non-thermal plasma (NTP). The non-thermal plasma was produced using Electrical discharge (such as DBD), which has its own limitations; such as it required many small unit in the scale-up, high voltage power source, contamination of the dielectric material. In the work reported in this paper, microwave is used with activated carbon, so there is no issue of the contamination or need for high voltage sources. Furthermore, scale up, microwave reactor is easy to construct and such reactors are already established technology in other industry such as food processing and material processing.

Fig. 4 shows the results obtained in the experiments with NO balanced in N_2 . NO concentration was 500ppm and gas flow was 2 l/min. Supplied microwave power (forward power – reflected power) ranged from 10 W to 45 W. Fig. 4(a) shows the outlet NO concentration for various supplied microwave power, which is shown in Fig. 4(b). As shown in this figure MW power was switched ‘ON’ after 3 mins of start of the experiment and stopped at 39th minute, and observed NO output for further 7 minutes.

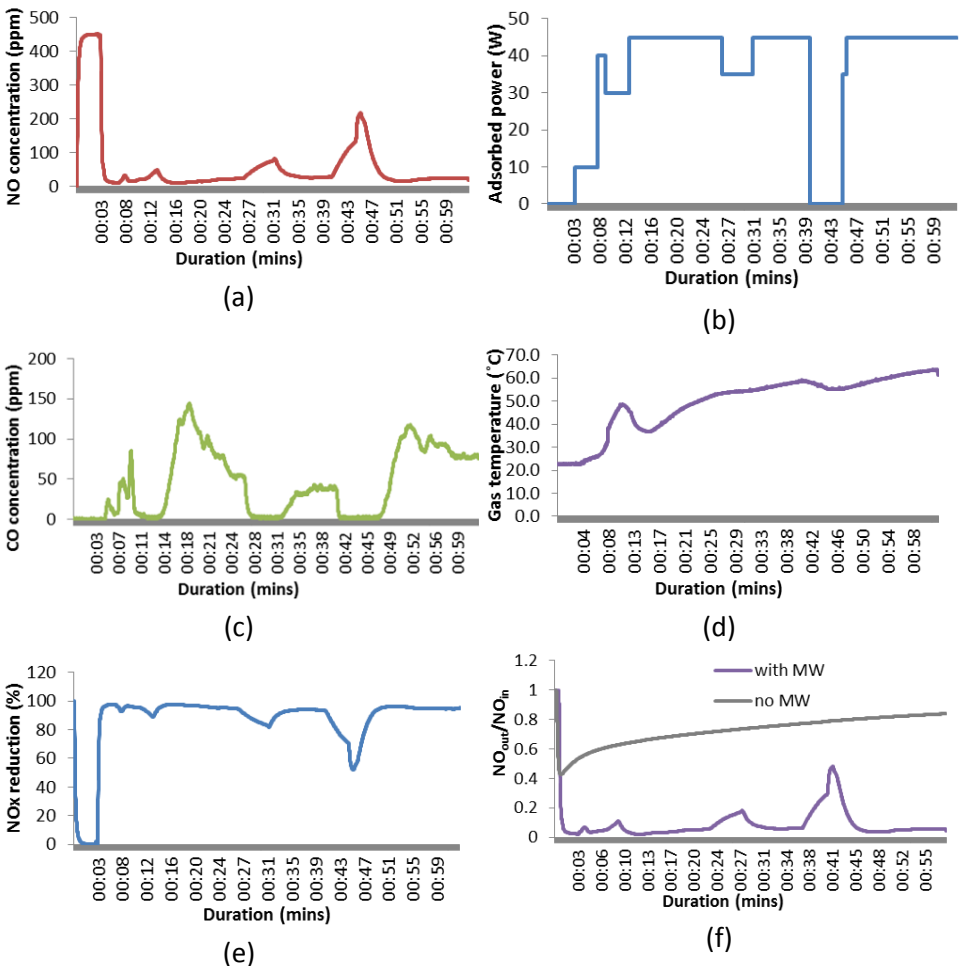

Fig. 4: Experimental results with NO balanced in N₂. (a) NO_x concentration (b) MW power supplied (c) CO concentration (d) Gas Temperature (e) % NO_x reduction (e) and (f) Concentration of NO (outlet): NO (inlet) ratio for with MW and without MW

Once MW was 'ON', NO concentration went down to very low level; almost 100% NO abatement. This clearly shows the effect of microwave on the GAC. Though it was not possible to notice any glow plasma within GAC bed, it can be safely assumed that silent plasma was present while MW was ON. When the microwave power increased to few hundreds of watts, GAC was producing glow plasma, however due to high electron energy in the plasma, more NO was produced rather than reduction. Therefore it is very important to maintain microwave power to a level, where silent plasma can be produced.

Fig. 4(c) and Fig. 4(d) show the CO concentration and outlet gas temperature. The reduction reaction of NO ($2\text{NO} \rightarrow \text{N}_2 + \text{O}_2$) must be the source for generating O_2 . The production of CO and its level (averaged value) was within safety limit; this was confirmed with the built in CO sensor in the lab. The temperature of the gas has gradually increased from its inlet temperature to 600C within an hour. This was due to microwave heating of carbon, as carbon's dielectric properties favours microwave heating. Fig. 4 (e) shows the reduction % of NO during the experiment and it was always very close 100% when microwave was 'ON'. Fig. 4(f) shows the ratio between NO_{out} : NO_{inlet} for the experiments with and without microwave. As it clearly shows, without microwave GAC simply adsorbs NO and the ratio slowly increases, whereas with microwave the ratio remains very low through the one hour experiment except the period MW was 'ON' between 39th minute and 46th minute.

The second sets of tests were performed to investigate the effects of O_2 in the test gas. The results obtained have not produced repeatable data. One of the results is shown in Fig. 5, where the NO concentration at the outlet was very unpredictable. The production of CO was also very unpredictable and consumed O_2 fully. This study needs further investigation.

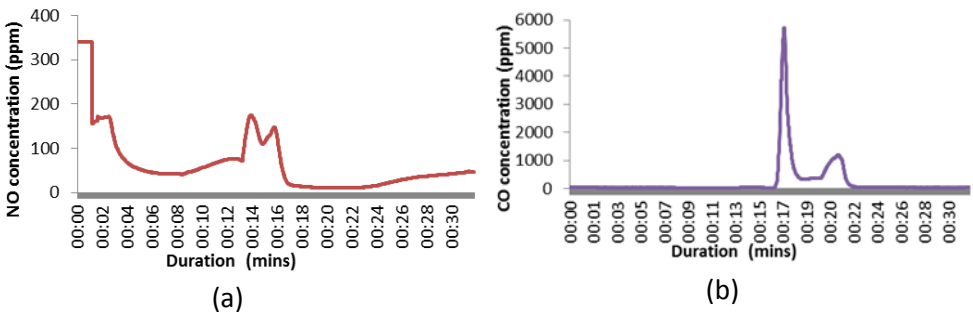

Fig. 5: Experimental results with the gas mixture of air and NO balanced N_2 (a) NOx concentration (b) CO concentration

V. CONCLUSIONS

Microwave micro non-thermal plasma was generated using granular activated carbon (GAC) in a single mode waveguide at the microwave frequency of 2.45GHz. Experimental results show that near 100% reduction of NO is achievable when O_2 is not in the inlet gas mix. Microwave power required for treating 2l/min was in between 10 to 45 W and this can be further improved through better position of GAC within the SMMC. Though some experimental results suggests that excellent abatement of NO can

be achieved in the presence of O₂, the plasma chemistry become complex and the behaviour of NO reduction is unpredictable. This requires further investigation.

VI. ACKNOWLEDGEMENTS

Authors wish to acknowledge InnovateUK for the financial support provided to the project 'Marine Exhaust Gas Treatment System (MAGS) {grant reference number 42471-295209}', in which, the presented work is part of.

REFERENCES

- [1] (March 1991). Risk Assessment for Toxic Air Pollutants: A Citizen's Guide. Available: http://www3.epa.gov/airtoxics/3_90_024.html.
- [2] C. Andersson, R. Bergström and C. Johansson, "Population exposure and mortality due to regional background PM in Europe – Long-term simulations of source region and shipping contributions," *Atmos. Environ.*, vol. 43, pp. 3614-3620, 7, 2009.
- [3] D. Gregory and N. Conforto, *A Practical Guide to Exhaust Gas Cleaning Systems for the Maritime Industry*. London: EGCSA, 2012.
- [4] 'Nitrogen Oxides (NO_x)', IMO MARPOL Regulation 13, 2015.
- [5] A. Chmielewski, "Application of ionizing radiation in environmental protection, "Radiation Treatment of Gaseous and Liquid Effluents for Contaminant Removal", pp. 11, 2005.
- [6] I. Calinescu, D. Ighigeanu, D. Martin and A. Bulearca, "Electron beam technologies for reducing SO₂ and NO_x emissions from thermal power plants," in WEC Regional Energy Forum–Foren, 2008, pp. 15-19.
- [7] Takuya Kuwahara, Keiichiro Yoshida, Tomoyuki Kuroki, Kenichi Hanamoto, Kazutoshi Sato, Masaaki Okubo, "Pilot-Scale Aftertreatment Using Non-thermal Plasma Reduction of Adsorbed NO_x in Marine Diesel-Engine Exhaust Gas", *Plasma Chemistry and Plasma Processing*, January 2014, Volume 34, Issue 1, pp 65-81.