

Criteria-Based Patent Mapping For Assessing Potential Conflicts Between Patent Claims

A Thesis Submitted for the Degree of Doctor of Philosophy

by

ZHENG LI

College of Engineering, Design and Physical Sciences

Brunel University London



September 2014

Abstract

Evaluating claim conflicts between patents is a crucial issue in patent applications and validity allegations. Existing patent informatics tools do not relate well to the legal requirements of identifying claim conflicts; innovation theory does not address patent evaluations; and the current legal approach has weaknesses in the repeatability between cases. Therefore, a need emerges to design a scientific method for evaluating conflicts between patent claims.

This thesis presents research on the topic of identifying, evaluating, and visualising patent conflicts. 'Conflict' is used to have the same meaning as **obviousness**, which is an essential legal term under the UK Patents Act 1977. Building on existing methods, this research provides a novel method called Criteria-Based Patent Mapping, for assessing claim conflicts between patents. 'Criteria-Based' means that this assessment uses evaluation criteria that clarify the inventive step of the patent. The source of these criteria is the well-known Theory of Inventive Problem Solving (TRIZ), which is incorporated into a statistical method of 'Patent Mapping' for evaluating and visualising differences between patent claims.

The application of the new method to four case studies shows that there are differences in judging standards between the legal authorities; and also shows an average value of 52% agreement in predicting potential conflicts between patent claims. Based upon these results, the original 39 TRIZ parameters can usually be refined to about 12 criteria. The scope of this method is restricted to patents in mechanical engineering due to the relevancy of TRIZ parameters.

This research transforms difficult claim-to-claim evaluations into simpler claim-to-criteria comparisons that lead to more efficient and transparent patent evaluations. Such improvements will be useful for better decision-making in patent strategy.

List of Contents

Abstract	I
List of Figures	VII
List of Tables.....	X
Preface.....	XIII
Acknowledgements	XIV
Author's Declaration.....	XV
Definitions and Nomenclatures	XVI
Chapter 1 Introduction	1
1.1 Research Object and Opportunity.....	1
1.2 Research Background in Three Aspects	2
1.2.1 Legal Aspect.....	2
1.2.2 Patent Informatics Aspect.....	4
1.2.3 Design and Innovation Aspect	5
1.3 Research Problem and Premises	6
1.4 Aim and Methodology	7
1.5 Summary of Chapter 1	11
Chapter 2 Literature Review.....	12
2.1 Introduction to Chapter 2	12
2.2 Insights of Obviousness.....	12
2.2.1 Generic-Specific Relationship Analysis.....	12
2.2.2 Part-Whole Relationship Analysis	13
2.2.3 Analysis of Structure of Argument.....	14
2.3 Patent Mapping and MDS-Based Patent Mapping	15
2.3.1 Existing Models of Patent Mapping.....	15
2.3.2 Fundamental of Patent Mapping	16
2.3.3 Patent Mapping Based on Natural Language Processing ..	18
2.3.4 Patent Mapping Based on Multi-Dimensional Scaling	18

2.4	TRIZ and TRIZ Engineering Parameters	22
2.4.1	Core Idea of TRIZ	22
2.4.2	TRIZ Engineering Parameters	23
2.5	Comparison of Patent Mapping and TRIZ	24
2.6	Other Relevant Methods about Patent and Innovation.....	25
2.6.1	QFD and F-Term.....	25
2.6.2	Life Cycles of Innovation and Patent	26
2.7	Summary of Chapter 2.....	29
Chapter 3 Method.....		30
3.1	Introduction to Chapter 3	30
3.2	Criteria-Based Patent Mapping	30
3.2.1	Definition of Elements	30
3.2.2	Evaluation of States.....	32
3.2.3	Calculation of Similarity.....	32
3.2.4	Visualisation of Vectors.....	33
3.2.5	Interpretation of Points	34
3.3	TRIZ-Led Patent Mapping.....	34
3.3.1	Combination of TRIZ and Patent Mapping	34
3.3.2	Framework of New Method	35
3.3.3	Evaluation Criteria.....	36
3.3.4	Evaluation Sheet	39
3.3.5	Dissimilarity Function.....	40
3.3.6	Visualisation by SPSS.....	43
3.3.7	Map Interpretation.....	43
3.3.8	Programming by MATLAB.....	44
3.4	Summary of Chapter 3.....	44
Chapter 4 Validation of Method		45
4.1	Introduction to Chapter 4	45
4.2	Case 1: Adjustable Aircraft Seat	46
4.2.1	Patents and Maps	46
4.2.2	Interpretation of Mapping Results	49
4.2.3	Summary of Case 1	50
4.3	Reliability Test.....	51

4.3.1	Consistency between Evaluators	51
4.3.2	Consistency over Time.....	51
4.3.3	Consistency between Criteria Sets	51
4.4	Validity Test	51
4.4.1	Combined Tests of Sensitivity and Specificity.....	51
4.4.2	Result Comparison	52
4.4.3	Combined Tests between Results.....	53
4.4.4	Combined Tests between Criteria Sets.....	54
4.5	Precision Calculation.....	55
4.6	Summary of Chapter 4.....	56
Chapter 5 Applications		58
5.1	Introduction to Chapter 5	58
5.2	Case 2: Nasal Prong Interface	59
5.2.1	Overview of Case 2	59
5.2.2	Using E_{12} in Case 2	60
5.2.3	Using E_{15} in Case 2	62
5.2.4	Using E_{12b} in Case 2.....	64
5.2.5	Improved E_k for Case 2.....	66
5.3	Case 3: Noise Reduction Device	67
5.3.1	Overview of Case 3	67
5.3.2	Using E_{12} in Case 3	68
5.3.3	Using E_{15} in Case 3	70
5.3.4	Using E_{12b} in Case 3.....	72
5.3.5	Improved E_k for Case 3.....	74
5.4	Case 4: Metal Enclosure	75
5.4.1	Overview of Case 4	75
5.4.2	Using E_{12} in Case 4	76
5.4.3	Using E_{15} in Case 4	77
5.4.4	Using E_{12b} in Case 4.....	80
5.4.5	Improved E_k for Case 4.....	82
5.5	Case 1 Amended	83
5.5.1	Overview of Case 1 Amended	83
5.5.2	Using E_{12} in Case 1 Amended	83

5.5.3	Using E_{15} in Case 1 Amended	85
5.5.4	Using E_{12b} in Case 1 Amended.....	86
5.5.5	Improved E_k for Case 1 Amended.....	89
5.6	Statistical Precision	90
5.7	Summary of Chapter 5.....	90
Chapter 6 Discussion		91
6.1	Introduction to Chapter 6	91
6.2	Evaluation Criteria	91
6.2.1	Finely Adjusting Evaluation Criteria	91
6.2.2	Improved Evaluation Criteria Set.....	91
6.3	Precision.....	92
6.3.1	Average Precision between Cases	92
6.3.2	Consequences of Precision for Prediction	93
6.4	Comparison of Legal Authority Standards	93
6.5	Alternative Statistical Methods	95
6.5.1	Relation of Criteria-Free and Criteria-Based MDS	95
6.5.2	Other Statistical Methods.....	95
6.6	Indices and Algorithm.....	96
6.6.1	Indices and Mission of Robustness	96
6.6.2	Summary of Research Algorithm.....	96
6.7	Advantages and Limitations.....	98
6.8	Legal Admissibility of the New Method	98
6.8.1	Conforming to the Existing Approach	98
6.8.2	Key Points for Forming Expert Reports.....	99
6.9	Proposal for A Third Way beyond Obviousness or Not.....	100
6.10	Summary of Chapter 6.....	101
Chapter 7 Conclusion.....		102
7.1	Summary of Contents of Research.....	102
7.2	Achieving Aim and Objectives	103
7.3	Contributions of Research.....	104
7.4	Future Work.....	104

Appendix A: Definition, Contexts, and Assessment Approach of Obviousness	105
Appendix B: Legal Basis and Brief History of Intellectual Property	112
Appendix C: 39 TRIZ Engineering Parameters.....	117
Appendix D: Refining TRIZ Parameters	120
Appendix E: Consistency of Evaluation Results	121
Appendix F: Evaluation Sheets	122
Appendix G: Evaluation Results.....	123
Glossaries and Abbreviations	125
List of References.....	127
Bibliography.....	137
Author's Publication.....	138
Postscript	139
Index	140

List of Figures

Figure 1.1 Research opportunity (gap) discovering.	001
Figure 1.2 Conceptual relationship of obviousness.	002
Figure 1.3 Premises (hard core) of the research problem.....	006
Figure 1.4 Objectives linking the chapters and the methods.....	008
Figure 1.5 Methodology of the research based on SSM.	009
Figure 2.1 Relationship between dependent and independent claims.	013
Figure 2.2 Arguments for validity of patents.....	014
Figure 2.3 Summary of typical process of patent mapping.	016
Figure 2.4 Illustration of reduction of dimensions in MDS.	020
Figure 2.5 MDS-based patent mapping.	021
Figure 2.6 Summary of typical process of patent mapping.	022
Figure 2.7 Demonstration of house of quality in QFD.	025
Figure 2.8 Anatomy of innovation.	027
Figure 2.9 Patent lifecycle.	028
Figure 3.1 Elements of the inventive concept.	031
Figure 3.2 Framework of TRIZ-Led Patent Mapping.	035
Figure 3.3 Refining engineering parameters in TRIZ: from 39 to 17.	037
Figure 3.4 Refining engineering parameters in TRIZ: from 17 to 12.	038

Figure 3.5 Reliability statistics results from SPSS.	038
Figure 3.6 Explanation of an evaluation sheet.	039
Figure 3.7 Relevance evaluation, similarity and dissimilarity calculation.	042
Figure 3.8 Sample of a mapping result of TRIZ-Led Patent Mapping.	043
Figure 4.1 Invention of target patent in Case 1: adjustable aircraft seat.	046
Figure 4.2 User interface (sample) for Case 1.	047
Figure 4.3 TRIZ-Led Patent Mapping of the aircraft seat case: using E_{12} . ..	048
Figure 4.4 Observing clustering in 3D maps: using E_{12}	049
Figure 5.1 Invention of target patent in Case 2: nasal prong interface.	059
Figure 5.2 Mapping results in Case 2: using E_{12}	060
Figure 5.3 Part of the mapping results in Case 2: using E_{12}	061
Figure 5.4 Mapping results in Case 2: using E_{15}	062
Figure 5.5 Part of the mapping results in Case 2: using E_{15}	063
Figure 5.6 Mapping results in Case 2: using E_{12b}	064
Figure 5.7 Part of the mapping results in Case 2: using E_{12b}	065
Figure 5.8 Invention of target patent in Case 3: noise reduction device.	067
Figure 5.9 Mapping results in Case 3: using E_{12}	068
Figure 5.10 Part of the mapping results in Case 3: using E_{12}	069
Figure 5.11 Mapping results in Case 3: using E_{15}	070
Figure 5.12 Part of the mapping results in Case 3: using E_{15}	071

Figure 5.13 Mapping results in Case 3: using E_{12b}	072
Figure 5.14 Part of the mapping results in Case 3: using E_{12b}	073
Figure 5.15 Part of the claim chart provided by the UK patent attorney.	075
Figure 5.16 Mapping results in Case 4: using E_{12}	076
Figure 5.17 Part of the mapping results in Case 4: using E_{12}	077
Figure 5.18 Mapping results in Case 4: using E_{15}	078
Figure 5.19 Part of the mapping results in Case 4: using E_{15}	079
Figure 5.20 Mapping results in Case 4: using E_{12b}	080
Figure 5.21 Part of the mapping results in Case 4: using E_{12b}	081
Figure 5.22 Mapping results of Case 1 amended: using E_{12}	083
Figure 5.23 Part of the mapping results of Case 1 amended: using E_{12}	084
Figure 5.24 Mapping results of Case 1 amended: using E_{15}	085
Figure 5.25 Part of the mapping results of Case 1 amended: using E_{15}	086
Figure 5.26 Mapping results of Case 1 amended: using E_{12b}	087
Figure 5.27 Part of the mapping results of Case 1 amended: using E_{12b}	088
Figure 6.1 Statistical precision among cases.	092
Figure 6.2 Comparing standards between legal authorities.	094
Figure 6.3 Summary of the algorithm of the research.	097
Figure D.1 Refining TRIZ parameters: from 39 to 17 and then to 12.	120

List of Tables

Table 1.1 Objectives distributing in chapters.	008
Table 1.2 Title interpretation and thesis navigation.....	011
Table 2.1 Comparing relationships between part-whole and generic-specific.	014
Table 2.2 Objects and models of data mining in patent mapping.	015
Table 2.3 Comparison: TRIZ and Patent Mapping.	024
Table 3.1 Composition: category of elements.	031
Table 3.2 Framework of TRIZ-Led Patent Mapping.	032
Table 4.1 Combined tests of sensitivity and specificity.	052
Table 4.2 Result comparison of Case 1: using E_{12}	053
Table 4.3 Combined tests in Case 1: using E_{12}	053
Table 4.4 Combined tests in Case 1: using E_{15}	054
Table 4.5 Combined tests in Case 1: using E_{12b}	055
Table 4.6 Precision and accuracy calculation.	056
Table 4.7 Cross-comparison between criteria sets and legal judgments. ...	056
Table 5.1 Combined tests in Case 2: using E_{12}	061
Table 5.2 Combined tests in Case 2: using E_{15}	063
Table 5.3 Combined tests in Case 2: using E_{12b}	065

Table 5.4 Precision and accuracy calculation for Case 2.	066
Table 5.5 Combined tests in Case 3: using E_{12}	069
Table 5.6 Combined tests in Case 3: using E_{15}	071
Table 5.7 Combined tests in Case 3: using E_{12b}	073
Table 5.8 Precision and accuracy calculation for Case 3.	074
Table 5.9 Combined tests in Case 4: using E_{12}	077
Table 5.10 Combined tests in Case 4: using E_{15}	079
Table 5.11 Combined tests in Case 4: using E_{12b}	081
Table 5.12 Precision and accuracy calculation for Case 4.	082
Table 5.13 Combined tests of Case 1 amended: using E_{12}	084
Table 5.14 Combined tests of Case 1 amended: using E_{15}	086
Table 5.15 Combined tests of Case 1 amended: using E_{12b}	088
Table 5.16 Precision and accuracy calculation for Case 1 amended.	089
Table 5.17 Average values of precision.	090
Table 6.1 Indices of TRIZ-Led Patent Mapping.	096
Table 6.2 Key points for writing up an expert report using TRIZ-Led Patent Mapping.	100
Table B.1 Theories of fundamental of IP.	112
Table C.1 TRIZ parameters and their explanations.	117
Table E.1 Consistency of evaluation results between using different sets of evaluation criteria in Case 4.	121

Table F.1 Example of the evaluation sheet in focus group studies.	122
Table F.2 Development of evaluation criteria sets.	122
Table G.1 TRIZ parameter relevance evaluation sheet in Case 1: using E_{12} parameters.	123

Preface

This is a thesis submitted to Brunel University for the degree of Doctor of Philosophy by Zheng Li, under the supervision of Dr Mark Atherton and Professor David Harrison from 2011 to 2014.

The format of the thesis complies with the “*Thesis Guidelines*” for a candidate for a research degree in Brunel University ([Brunel University, 2014](#)), which highlights that the [British Standard 4821:1990](#) (BS4821:1990) “*Recommendations for the Presentation of Theses and Dissertations*” ([British Standard Institution, 1990](#)) should be consulted, including font, font size, spacing, margin, table, figure, heading, section, pagination, title page, and hard cover.

The referencing style follows the [Harvard Referencing Guide](#) ([Brunel Library, 2013](#)) except those legal authorities in text, e.g. legislations, lawsuit cases, and judicial reports, to which the [Oxford Standard for the Citation of Legal Authorities](#) (OSCOLA) 2006 ([Oxford University, 2006](#)) is applied unless ambiguousness occurs, because the validity of the theme and the outcome of the research are subject to the UK law system.

Two types of keywords are emphasised from here on: (a) those keywords in bold, collected in the Glossaries and Abbreviations below, are existing terminologies in certain subjects and defined according to the published sources; (b) those keywords with underlines are concepts defined in the texts and listed in the Definitions and Nomenclatures below. The keywords are collected in the Index at the end of the thesis.

Other formats not mentioned above follow the [ISO/IEC Directives](#), such as hanging paragraphs and list numbering ([ISO/IEC, 1997: p.16-7](#)); words and phrases not defined particularly are used according to the [Oxford English Dictionary](#) (OED) 2014.

Acknowledgements

I would like to show my deep appreciations to Dr Mark Atherton, my principal supervisor, for his great guidance during my three-year PhD study. Mark is a gentleman, with noble personality. He is more than an expert in navigating and sailing our research-ship in the wild ocean of knowledge to discover a new land, but also a trustable friend sharing happiness with me from his colourful life, loves of his family, various kinds of humours, and our academic research. “*Just be yourself*”, said my Captain, “*be absolutely crystal clear, Vincent!*”, and “*no more pictures of brains.*”

Sincere thanks also go to my dear second supervisor Professor David Harrison, who is an excellent teacher, giving generous helps. Meanwhile, I would like to express my gratitude to my first tutor in the UK, Dr Ray Holland.

Many thanks to our industrial partners Mr Frede Jensen, Mr Kevin Ambrose, Mr John Bilko, Mr Simon Carr, and Mr David Pearce, who gave their expert suggestions and supports to this work; my dear friends and research fellows Feifei Jiao, Chao Liu who gave generous helps in programming.

Special thanks go to the examiners of my viva voce, Dr Richard Bonser and Professor Mark Hadfield, and also the two anonymous paper examiners from the Journal of *World Patent Information*, for their patient examinations, constructive questions and insightful suggestions which are vitally important to help me improve the research.

Many names I cannot write down one by one, who have given kind helps to me. Thank you all very much. And, thanks to Brunel University, my cosy home in the UK.

Finally, my loves go to my mum Hongyan Zheng and my dad Lianjun Li. The meaning of my life is of their loves and for their loves.

Zheng Li

Brunel University London

Author's Declaration

The research presented in this thesis is the original work of the author except where otherwise specified, or where acknowledgements are made by references. This project was carried out at the College of Engineering, Design and Physical Sciences, Brunel University, under the supervision of Dr Mark Atherton and Professor David Harrison.

The work has not been submitted for another degree or award to any other institution.

Definitions and Nomenclatures

Keywords	Definitions
Absolute similarity	The relationship of sharing the same active elements of the inventive concept between patent claims. Number of common active elements represents substantial similarity.
Criteria-Based Patent Mapping	The new model for evaluating and visualising differences between patent claims that is based on evaluation criteria and adjusts its evaluation criteria according to its precisions comparing with real results.
Elements of the inventive concept	Conceptual units in the inventive concept defined in patent laws, having two states and six categories, specified as refined engineering parameters of TRIZ.
Patent claim conflict	Or conflicts between patent claims, means obviousness (legal term), i.e. no essential difference.
Relative similarity	The relationship of active elements of the inventive concept in each patent claim. Number of all active elements of each claim represents phenomenal differences between each claim.
TRIZ-Led Patent Mapping	The new method to assess conflicts between patent claims using refined TRIZ parameters as criteria.
Nomenclatures	Explanations
C_n	The number, n , of patent claims, i.e. the claim n .
d_{ij}	Dissimilarity, $d_{ij}=1-s_{ij}$.
E_k	Sets of elements of the inventive concept with k elements (criteria).
k_n	Number of dimension (or criteria) of the claim n .
m_{ij}	Common criteria between claim i and claim j .
s_{ij}	Similarity between claim i and claim j .

Chapter 1 Introduction

1.1 Research Object and Opportunity

This thesis presents research on the topic of evaluating conflicts between patent claims. “Conflict” represents **obvious**, which is an essential legal term of the second condition of patentability and the necessary requirement of validity of patents under the [UK Patents Act 1977](#). The research object can be also stated as assessment of **obviousness**.

Evaluating patent conflict is a multidisciplinary subject involving patent laws, patent informatics, and technical innovation. Each aspect has links and gaps with the others:

- (1) Evaluating patent conflict is an expertise and privilege belonging to patent examiners, attorneys, and court judges. In spite of various ways to assess **obviousness** in different legal systems, there is only one legally admissible approach in the UK, regulated in [Pozzoli SPA v BDMO SA \[2007\] EWCA Civ 588](#), the **Windsurfing/Pozzoli approach** ([Appendix A: p.109](#));
- (2) Compared with the only legal approach, there are plenty of informatics methods ([Abbas, Zhang, and Khan, 2014](#)) for searching and classifying patent information in databases (prior art) to identify distributions of patents and trends of technologies. However, none of them has been found involving analysis of the legal determinant, inventive concept ([Appendix A: p.108](#)); and
- (3) From engineers’ perspectives, the inventive concept in patents is a main theme, which is summarised by theories of product design and innovation, such as the Theory of Inventive Problem Solving (TRIZ) ([Altshuller, 1999](#)). But TRIZ solely focuses on analysing contradictions and predicting possible solutions, not identifying or evaluating claim conflict.

Therefore, a research opportunity has been revealed in the cross area ([Figure 1.1](#)), which is the contribution of this thesis attempts to make and has been achieved. The research rationale is combining TRIZ and patent mapping to solve patent issues.

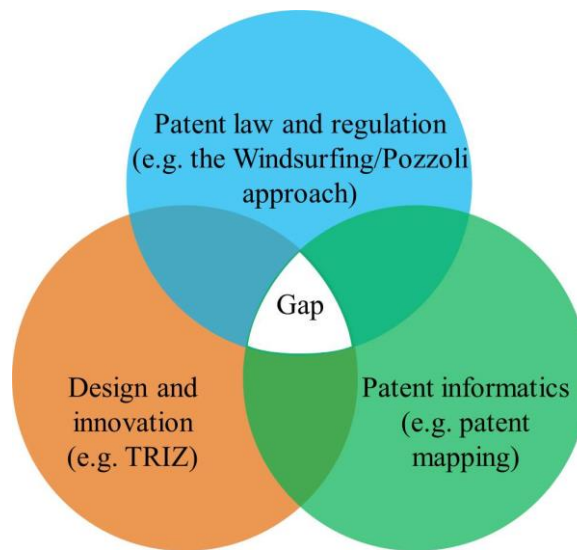
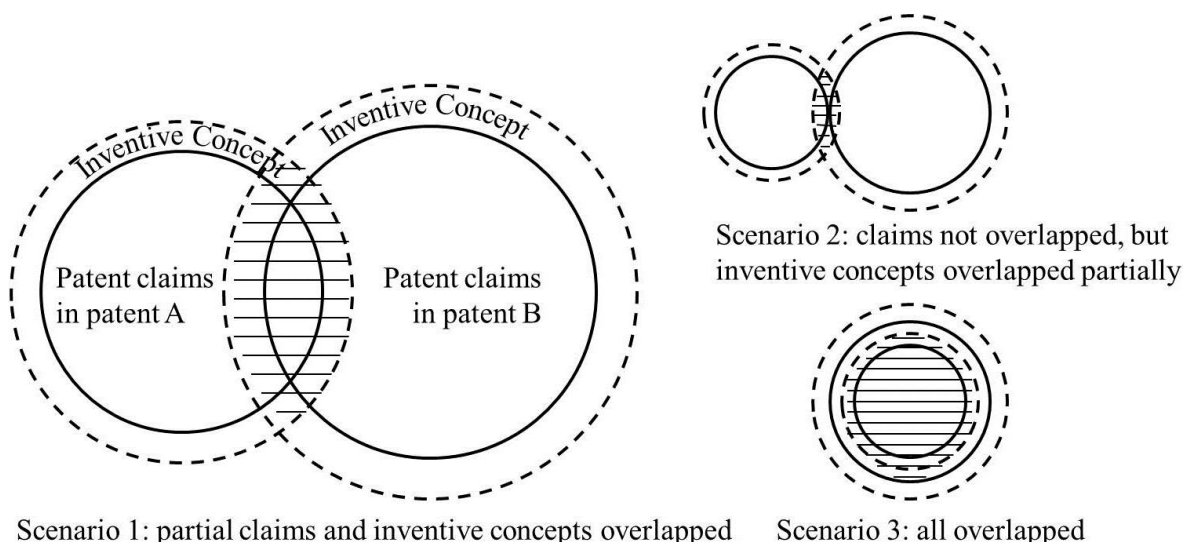

Figure 1.1 Research opportunity (gap) discovering.

1.2 Research Background in Three Aspects

1.2.1 Legal Aspect

Briefly, **obviousness** means “unessential differences” (Kemp, 1983: 19-25), which is a part-whole relationship between patents (Figure 1.2).



Those similar inventive concepts (illustrated as overlapped shadows) imply obviousness

Figure 1.2 Conceptual relationship of obviousness.

Scope of claims is represented by solid-lines while the inventive concept, dash-lines.

Such a part-whole relationship is a paradox, i.e. easily to make logical fallacy. It means that partial claims with similar inventive concept may lead obvious as a whole while patents with **non-obviousness** relationship as a whole may still contain similar claims in part. The detail definitions and contexts of **obviousness** are shown in [Appendix A: p.105](#). Despite partial **obviousness** is insufficient to argue holistic **obviousness**, it is necessary to evaluate claim conflicts partially because parts are basis of the whole.

In addition, to comprehend patent **obviousness**, it is necessary to have a holistic view of Intellectual Property (IP) and IP Right (IPR). [Appendix B](#) shows the summary of the legal basis and brief history of IP and IPR.

The **Windsurfing/Pozzoli approach** is four-step guideline for deciding obvious or not, see the [Pozzoli SPA v BDMO SA \[2007\] EWCA Civ 588](#):

“(1)(a) Identify the notional ‘person skilled in the art’;

(1)(b) Identify the relevant common general knowledge of that person [detailed discussions of the first step are stated in the [Appendix A: p.109](#)];

(2) Identify the inventive concept of the claim in question or if that cannot readily be done, construe it;

(3) Identify what, if any, differences exist between the matter cited as forming part of the ‘state of the art’ and the inventive concept of the claim or the claim as construed;

(4) Viewed without any knowledge of the alleged invention as claimed, do those differences constitute steps which would have been obvious to the person skilled in the art or do they require any degree of invention?”

However, there are three shortages in it:

(1) Its four steps is a diminishing argument chain where degrees of arguments decrease step by step;

- (2) It is a single-way, a closed-circle, for checking existing cases, not including any feedback process for corrections or predictions; and
- (3) It is only one of the necessary but not sufficient conditions of arguing obviousness. The other conditions, such as commercial realities and technical collocations are not involved in this new method.

Therefore, “part-whole relationship”, “diminishing degree of argument”, “closed, non-feedback process” and “necessary but not sufficient condition” are the four major difficulties in assessment of **obviousness**. The first and fourth difficulties are related to legal definitions, which cannot be easily changed because they are still reasonable and no systematic replacement has been made; the second weakness can be strengthened by providing alternative and paralleled approach to assessing **obviousness**, which is the output of this research; and to solve the third problem, methods from patent informatics (patent mapping) and theories from technology innovation (TRIZ) can be used for reference, in which feedback and prediction are included.

1.2.2 Patent Informatics Aspect

From informatics perspective, a patent can be seen as a combination of information; differences between patents can be identified through data analysis. Information in patents can be categorised into two kinds: structured and unstructured (Kim et al., 2007; Suh and Park, 2006). Structured information in patents is data that is formatted and stored in patent databases which can be typed into the form of bytes, retrieved and reconstructed by designed algorithms, such as patent names, publication dates, etc.; unstructured information refers to the inventive concept in patent claims, descriptions, and drawings, which is too irregular to be recognised or extracted by computer programmes. Most state-of-the-art techniques of patent information analysis only deal with structured information while only a few are designed for unstructured information (Kim et al., 2007; Suh and Park, 2006; Liparas et al., 2014).

Patent mapping is a typical informatics way to analyse structured information in patents, firstly introduced by the Japan Patent Office (JPO) in 1968. It is a series of data search,

mining, and visualisation methods based on statistical analysis to reveal connections and gaps between patented technologies (JPO, 2000), which are important to commercial competition. Meantime, classification systems for global patents were also developed in the 1970s, i.e. International Patent Classification (IPC). In 1980, File Forming Term (F-term) began to be used by JPO. In recent decades, Cooperative Patent Classification (CPC) was developed by the US patent office and the European Patent Office (EPO) (EPO, 2014).

Both methods of patent mapping and classification cannot deal with legal issues, particularly, **obviousness** because of two reasons: on one hand, patent informatics processing is effective and efficient in analysing with structured data while the inventive concept is unstructured; on the other hand, **obviousness** assessment requires many restrictions, such as human evaluation, qualitative not quantitative test, etc. while only few informatics tools meet these conditions. Thus, patent mapping and classification methods need to be improved according to legal requirements and design and innovation theories.

1.2.3 Design and Innovation Aspect

Faced with inventive problems, engineers and designers can seek help from theories of innovation and design. There are two theories well-acknowledged and used in design practice, TRIZ and QFD (acronyms are explained here below).

TRIZ is a Russian acronym which is standing for Theoria Resheneyva Isobretatelskehuh Zadach, translated as the Theory of Inventive Problem Solving, created by Genrikh Saulovich Altshuller around 1960, developed and spread around the world since 1990s. It is a theory and method for solving mechanical design problems, and also analysing and forecasting technologies (Altshuller, 1999; Mann, 2001). It summarises engineering parameters (Appendix C) to describe contradictory characteristics in technical systems and lists inventive principles as possible solutions of contradictions.

QFD is an abbreviation of Quality Function Deployment, which is an evaluation method of product design, providing evaluation criteria (Yamashina, Ito, and Kawada, 2002). It

was firstly appeared around 1970s in the Japanese manufacturers as a method of design management, described by Dr Yoji Akao ([Griffin and Somermeyer, 2007: p.39](#)).

Both these theories are not suitable for analysing patent information or comparing existing patents, i.e. prior art, although TRIZ and QFD provides engineering parameters and evaluation criteria respectively, which are similar concepts to the inventive concept asked for in the patent law. Hence, to absorb useful points in these theories for building up a new method to assess **obviousness** is the solution to the problem of this research.

1.3 Research Problem and Premises

The main problem of the research is stated as:

Under the admissibility of current legal approach for evaluating patent claim conflict (assessing “obvious or not”), how to identify, evaluate, and visualise conflicts between patent claims?

The pre-set binary proposition “obvious or not” is the premise of the research problem. To have an insight of the fundamental of the problem is necessary for avoiding logical dilemma. The premises are analysed as following ([Figure 1.3](#)):

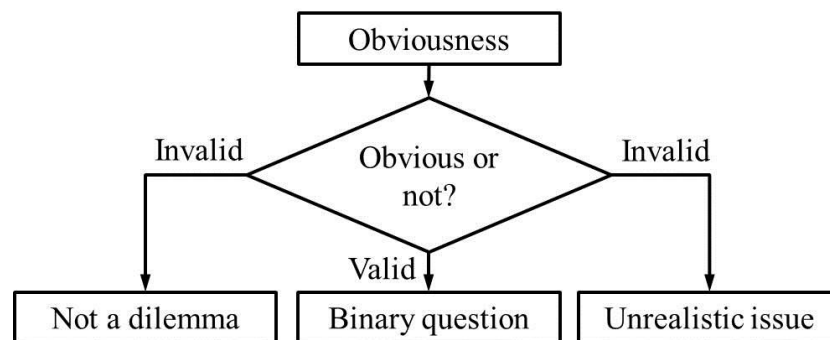

Figure 1.3 Premises (hard core) of the research problem.

- (1) If the question was not a dilemma, then other answers should be discussed;
- (2) If **obviousness** can be assessed in practice, then the answer is “Yes or No”. “can be assessed” is the core of this binary question; and

(3) If assessing **obviousness** was impossible, then no certain answer could be drawn. So the question is unrealistic and the answer is “unknown”.

Under the premise (2) above (the premises (1) is discussed in [Chapter 6](#)), the research problem is depended on the definition of **obviousness** and its verification. As the current definition is reasonable, the main problem is focused on the verification, i.e. the assessment methods.

1.4 Aim and Methodology

The aim of the research is set up as:

Based on learning from theories and methods of patent informatics and technology innovation, to design a scientific method that can identify, evaluate, and visualise conflicts between patent claims in order to admissibly assess **obviousness** and enhance arguments for probability of **obviousness**.

This aim comprises seven objectives (linked with the chapters [Table 1.1](#)).

- (1) Topic identification: to identify the research problem and its premises, i.e. **obviousness**, according to the existing literature;
- (2) Definition and reasoning: based on the existing literature, to clarify the definition of **obviousness**, its relevant concepts, and the background of the UK law of patents;
- (3) Studying the existing: to analyse the existing methods in patent informatics and technology innovation, e.g. patent mapping and TRIZ;
- (4) Studying the potential: to study existing models in other systems relevant to patent system, such as life cycle models of patents and innovations;
- (5) Rationality realisation: to design a new method that composes evaluation criteria (representing the inventive concept) and feedback process;

(6) Falsifiability: to validate the new method by comparing results in existing cases with results generated by the new method;

(7) Practical application: to apply new method to practical problems in order to accumulate more case studies for improving the new model.

Table 1.1 Objectives distributing in chapters.

Objective		Chapter	
(1)	Topic identification	1	Introduction
(2)	Definition and reasoning	2	Literature review
(3)	Studying the existing	2	Literature review
(4)	Studying the potential	2	Literature review
(5)	Rationality realisation	3	Modelling
(6)	Falsifiability	4	Result and validation
(7)	Practical application	5	Application

Most methods in the research are based on analysis of reduction, i.e. comprehending a system by its elements. To achieve the objectives, various analytical methods are adopted, among which the main methods can be highlighted to link methods with chapters ([Figure 1.4](#)).

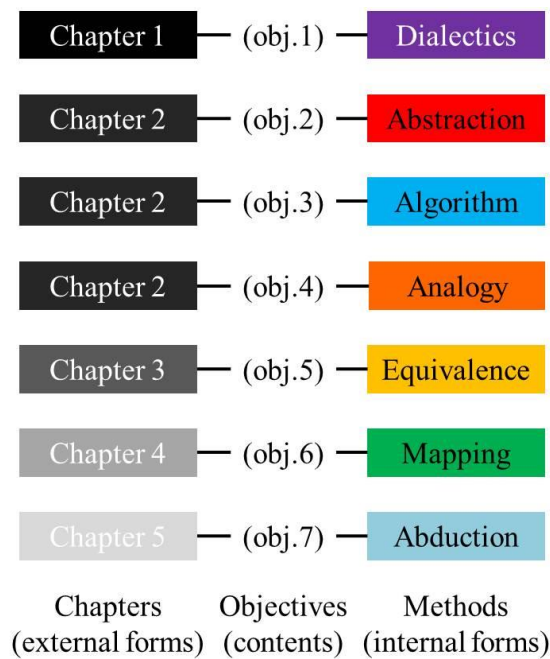

Figure 1.4 Objectives linking the chapters and the methods.

Remark: dialectics is the predominant method that contains more than analysis.

The research adopts the Soft Systems Methodology (SSM) for establishing a framework to organise methods. SSM does not directly produce solutions, but provides a learning process to approximate varied levels of maturity of open systems (Checkland and Scholes, 1999; Juan, 2006, p.20). It is suitable for researching conflicts (**obviousness**) between patent claims because a patent, or patent system, is a typical open system (Li, 2002: p.124-32), in which it is possible to decrease entropy for increasing the order of the system by adding new patents, or expiring and revoking invalid ones.

SSM outlines a three stage-framework to organise the seven methods (Figure 1.5).

- (1) Position: no feedback is in the circle of obj.(1)-(2)-(3)-(7)-(1);
- (2) Negation: a negative feedback is in the spiral of obj.(5)-(6)-(7)-(5), where new models are amended iteratively; and

(3) Negation of negation: a positive feedback is in the cycle of obj.(1)-(2)-(4)-(5)-(1), which is a learning process (Li, 2002: p.88-115) that emerges new problems by absorbing new models.

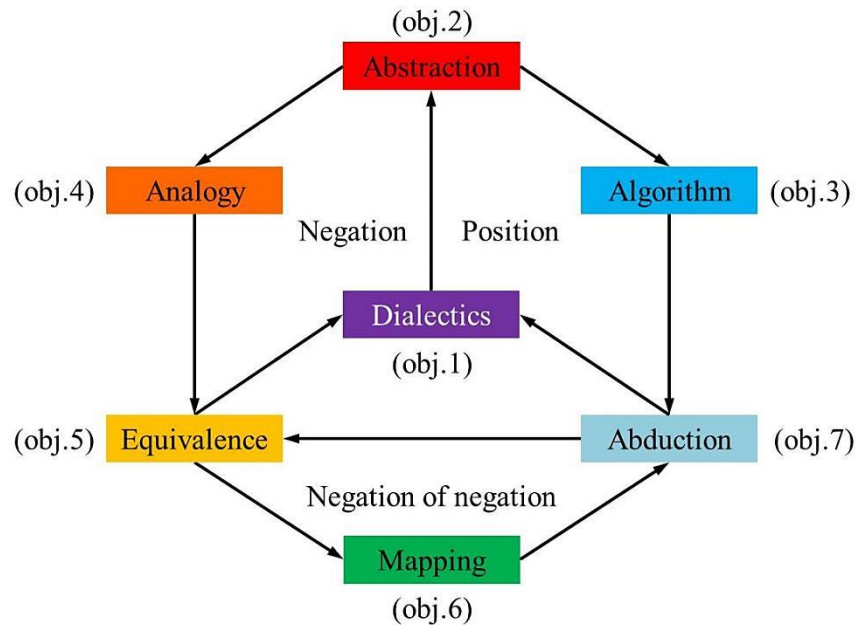

Figure 1.5 Methodology of the research based on Soft Systems Methodology (SSM).

This framework is adapted from the Checkland and Scholes’s SSM framework (Checkland and Scholes, 1999) but redesigned and clarified by the author to highlight the dialectical thinking in the framework. The arrows show the directions of the logical flow.

The logical starting point of this research is Dasein (Hegel, 1816), meaning state of existence, i.e. matters, which are eternally evolving and universally connected. This basis indicates that willingness or subjectivity is mentioned but not discussed much in this research, such as offence intention of infringement (UKIPO, 2014: p.4) and “pith and marrow” of claims, i.e. essential ideas of claims (Miller et al., 2010: s.9-19; Kemp, 1983: 19-23). Here, matters are described by two properties: relationship and attribute, which are defined as below (Gu, 2000: p.45,52):

- (1) A relationship (or relationship between matters, or relationship property of matters) means the state of existence between matters, i.e. external forms of matters, e.g. fast, fair, etc.; and there are two types of relationships in specific contexts: either part-whole relationship or generic-specific relationship;

(2) An attribute (or attributes within matters, or attribute property of matters) means the state of existence within matters, i.e. internal contents of matters, e.g. resilience, mass, etc.

Contents determine forms while forms reflect contents. For instance, a relationship between patents is just the form of connections of contents within patents. In another word, it is axiomatic that **obviousness** between patents can be mapped by patent claim conflicts within patents. This is the fundamental philosophy of the research.

1.5 Summary of Chapter 1

The contents of the research are constructed in the title of the thesis ([Table 1.2](#)).

Table 1.2 Title interpretation and thesis navigation.

Title	Content	
Conflicts between patent claims	Object (what)	Chapter 1-2
Criteria-Based Patent Mapping	Model (how)	Chapter 3-5
Assessing Potential Conflicts	Purpose (why)	Chapter 6

Chapter 1 and Chapter 2 clarify the demands of improving current patent analysis methods for evaluating patent claim conflicts (assessing **obviousness**); the next two chapters present the details of the new method; Chapter 5 includes four case studies, demonstrating the applications of the new method; [Chapter 6](#) discusses improved criteria, average precision, authority standards comparison, and key points of expert report forming; Chapter 7 summarise the conclusions of the research.

Chapter 2 Literature Review

2.1 Introduction to Chapter 2

Chapter 2 mainly presents the literature review of patent mapping and TRIZ. But at the beginning, an in-depth study of legal regulations of **obviousness** is carried out because without considerations of legal admissibility, results from tools of patent informatics or innovation will be unacceptable in the legal field (patent allegation or litigation). Hence, legal insights of **obviousness** have been highlighted as the precondition of this research.

2.2 Insights of Obviousness

2.2.1 Generic-Specific Relationship Analysis

Patent claims (described in the [Patents Act 1977 s.14\(5\)](#) and [EPC Rule 43\(1\)](#)), can be categorised as independent claims (previous or antecedent claims) and dependent claims (sub-claims or subsidiary claims). As explained in [Patent Teaching Kit PC 9](#), if an independent claim is invalid, its dependent claims may still be valid. Thus, it is a part-whole relationship between dependent-independent claims.

The logical relationships between the patent validity, obviousness, patent claim, etc. are synthesised below, where the symbol “ \rightarrow ” means “imply”, the conjunction of sufficient relationship used in the formal logic ([Gu, 2000: p.78](#)):

- (1) Valid patents \rightarrow **non-obviousness** \rightarrow differences; equivalently, similarities (non-differences) \rightarrow **obviousness** \rightarrow invalidity;
- (2) Valid patents \rightarrow **non-obviousness** \rightarrow inventive step \rightarrow inventive concept; the equivalent is omitted; and
- (3) Patent claims \rightarrow inventive concept.

The legal terms such as inventive concept and inventive step are summarised and clarified in the [Appendix A: p.108](#).

2.2.2 Part-Whole Relationship Analysis

A syllogistic reasoning (Figure 2.1) is made for clarifying independent claim and its dependent claims: they are a part-whole (dependent-independent) relationship:

(1) A reduction to absurdity: if it was generic-specific relationship between independent (generic) and dependent (specific) claims, then generic invalidity should result in specific invalidity. However, independent claim is invalid while dependent claim may still be valid (see patent claims definition (4) in Appendix A, p.107). Such a result (generic **obviousness** leads to specific **non-obviousness**) is a logical fallacy. So it must not be a generic-specific relationship;

(2) In formal logic, a binary choice can be made: there are only two types of relationships (either part-whole or generic-specific, see Chapter 1) representing connections of matters, either part-whole or generic-specific; and

(3) Therefore, usually, it is a part-whole relationship.

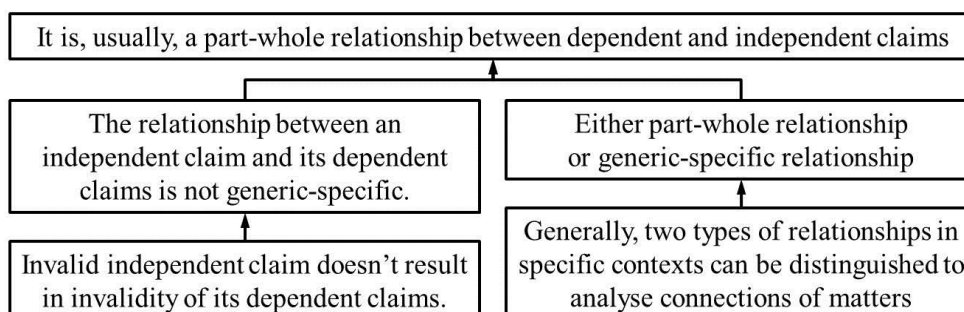

Figure 2.1 Relationship between dependent and independent claims.

To clarify **obviousness**, which is also a part-whole relationship between patent claims, and avoid the logical fallacy, a relationship comparison is built in Table 2.1. Seeing the part-whole column, it is a conclusion that under no circumstances can **obviousness** or **non-obviousness** between patent claims sufficiently determine **obviousness** or **non-obviousness** of whole patents; neither sufficient from whole to part. As a result, assessing **obviousness** is lack of logical sufficiency, which is a paradox of the current patent system in the UK.

Table 2.1 Comparing claim relationships between part-whole and generic-specific.

Part-whole (current real situation)	Generic-specific (pitfall)	Comparison
A patent (all claims) is obvious → a claim may be obvious and at least one claim is obvious	A patent (all claims) is obvious → every claim is obvious (certainty)	Different
A claim is obvious → a patent may be obvious	A claim is obvious → a patent may be obvious	The same (pitfall)
A patent is non-obvious → a claim maybe non-obvious and at least one claim is non-obvious	A patent is non-obvious → every claim is non-obvious (certainty)	Different
A claim is non-obvious → a patent may be non-obvious	A claim is non-obvious → a patent may be non-obvious	The same (pitfall)

2.2.3 Analysis of Structure of Argument

The influence of the lack of sufficiency is that a typical patent system provides split judgments to **obviousness** between partial patent claims and all claims (patents): search reports by patent offices and judgments by patent courts. Search reports can identify obvious patent claims which could be a cause of litigations. Meanwhile, patent courts have rights to either judge obvious claims between patents, no matter no obvious claim is found in search reports; or, judge **non-obviousness** as a whole, even though some claims are identified as obvious in search reports. Such a split of judgments is rooted in the legal hierarchy of administration-jurisdiction relationship, like a consequence of part-whole logical relationship, not generic-specific. As the logic of the part-whole relationship is hardly denied (is rational), the split of patent system is not absurd (is reasonable). The influence of the insufficiency is not only found in **obviousness** assessment, but also in validity arguments (Figure 2.2):

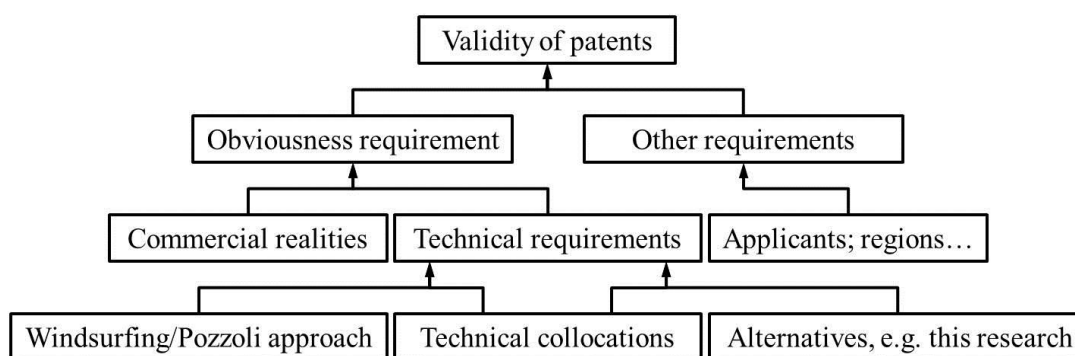
**Figure 2.2 Arguments for validity of patents.**

- (1) Most arguments on lower level are insufficient to higher ones; and
- (2) Degrees of proof are diminishing between insufficient arguments.

For instance, if **obviousness** is assessed as 51% by the **Windsurfing/Pozzoli approach**, 49% by technical collocation checking, 50% in commercial reality consideration, then validity of technical requirements is 25% ($51\% \times 49\%$) and validity of **obviousness** is 13% ($51\% \times 49\% \times 50\%$). If an alternative approach argues 49%, then the result will be 12% ($49\% \times 49\% \times 50\%$). This “1% argument” is what this research attempts to contribute.

2.3 Patent Mapping and MDS-Based Patent Mapping

2.3.1 Existing Models of Patent Mapping

A primary literature review based on the keywords of “patent map” and “patent data mining” has been carried out using the Summon search engine, which is an one-stop-shop library search tool including comprehensive many Brunel’s journal databases ([Brunel University Library, 2014](#)). Sixty-five relevant journal papers were selected out of ninety-four papers found based on the keywords. The result of the literature review has been summarised in [Table 2.2](#).

Table 2.2 Typical existing models of patent mapping.

Objects	Typical existing models
Mainly, structured and unstructured data in patents such as application dates, classification numbers, drawings, and keywords in claims and descriptions.	SOFM model (Yoon et al., 2002); NLP-based (Cascini et al., 2004); CVS model (Uchida et al., 2004); <i>K</i> -means & semantic network theory (Kim et al., 2007; Suh and Park, 2006); SAO model (Park et al., 2012); MDS-based model (Janssens et al., 2006; Chen and Chen, 2007; Chen, 2009).

The typical process of patent mapping is drawn into [Figure 2.3](#):

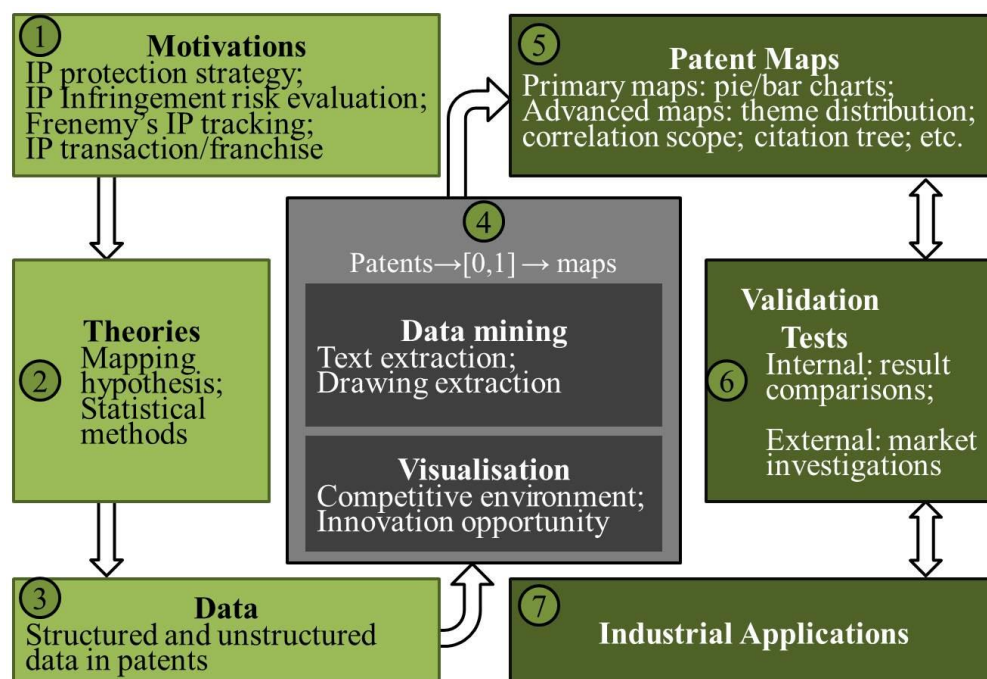

Figure 2.3 Summary of typical process of patent mapping.

2.3.2 Fundamental of Patent Mapping

Patent map, as a strategic instrument of patent information integration, requires sufficient sample statistics and effective data mining (clustering, and classification) methods and data visualisation technology. Data mining is the basis of data visualisation while multivariate data analysis is the fundamental of data mining.

Many methods in multivariate data analysis have been applied for solving problems in data processing with the benefit of computers. For instance, *K*-means patent mapping (Kim et al., 2007; Suh and Park, 2006) applied *K*-means clustering method to visualise keywords extracted from patents. Nodes in such patent maps are keywords while distance represents similarity. However, the number of clusters, i.e. *K*, is determined by map producers based on subjective experience, which can result in inappropriate clustering. In addition, there is no proper procedure to validate whether *K* is appropriate or not (Ren and Yu, 2011). Uchida's CVS model uses co-occurrence to avoid human clustering. CVS is Concept Vector Space. Concept-based word Vector is constructed according to word co-occurrence in a patent, which then is used to represent the patent characteristics. Characterised patents are seen as Vector Space in which two patents can

be calculated and compared to reveal their correlations. This method shows accuracy in clustering but ambiguity in labelling clusters because of lack of human involved evaluation.

Nowadays, these analytical methods have become the fundamental of data mining for patent mapping. But to solve real problems in patent system, understanding of meaning of texts is a necessary step for a computer programme to process information in patents. Therefore, two directions diverged in the development of patent mapping design: one is computer evaluation patent mapping; the other is human evaluation patent mapping.

To allow computer programme to “read and understand” contents of patents, text statistical analysis, linguistic analysis methods, etc. are combined in patent mapping. Yoon developed a Self-Organising Feature Map (SOFM, [Yoon et al., 2002](#)) which applied network and principal component analysis in patent mapping. From keywords extraction to correlation calculation, such method achieves dimension-reduction and data visualisation without much human involved evaluation. Another typical language analysis method is Natural Language Processing (NLP). Most structured data in patents can be extracted and processed by specific NLP algorithms. However, most unstructured data, such as drawings, the inventive concept in drawings and patent claims are not able to be recognised or collected by simple programmes. Human evaluation on unstructured data has also been combined with methods of multivariate data analysis, such as Multi-Dimensional Scaling (MDS).

A patent map is only a reference, a guideline in decision making. But this guideline is, although of uncertainty and ambiguity, often vitally important and necessary to product and market managers because there is no other tool that can collect all information in a competition environment, and provide certain conclusions to a quickly varying market. Theoretically, the limitations of mathematical statistics are the kernel problems of patent mapping, which is an internal system error influencing the practical reliability.

2.3.3 Patent Mapping Based on Natural Language Processing

Natural Language Processing, as techniques for text mining and information retrieval, are finding application in analysis of many kinds of document, including patents (Cascini, Fantechi, and Spinicci, 2004). NLP in patent mapping focused on a functional description of an invention, i.e. information in patents including descriptions and claims. Many models are developed following the logic of NLP, e.g. the SAO model. Subjects, Actions, and Objects (SAO) of a sentence in descriptions and claims in patents can be identified, i.e. identifying functions by SAO triads. These SAO triads are components in the functional level of an invention, based on which correlations of patents can be analysed and compared. In summary, NLP is a logical instruction used to extract SAO structure in texts and SAO triads are reconstructed for purposed of data clustering and classification in different patent issues.

2.3.4 Patent Mapping Based on Multi-Dimensional Scaling

Multi-Dimensional Scaling (MDS) can be used for patent mapping (Chen, 2009; Chen and Chen, 2007), and has been widely applied in psychological analysis to evaluate overall impressions or subjective opinions on an object and then derive spatial positions in multidimensional space reflecting these perceptions (Hair, Tatham, and Black, 1995: p.1995:484-555; Ren and Yu, 2011: p.302-11).

The major function of MDS, in general, by defining n as a number of points and k as a number of dimensions or criteria (mathematically, k is a dimension; in MDS evaluations, k is also called as criterion), is to transform data (e.g., scores arranged from evaluation sheets) from a high dimensional space ($k \gg 3$) to a low dimensional space (usually $k \leq 3$) through iterative computations. Such iterative computations are carried out to find an optimised low-dimension matrix that visualises the complex correlations in the original matrix with sufficient clarity, see Figure 2.4.

In the $n \times k$ matrix $\mathbf{A} = [a]_{n \times k}$ shown in Figure 2.4, there are n points A_1, A_2, \dots, A_n in the k -dimensional vector space, i.e. $\mathbf{A} = [A_1, A_2, \dots, A_n]^T$, $i = 1, 2, \dots, n$. Each point has multidimensional coordinates, $A_i = [a_1, a_2, \dots, a_k]$, $i = 1, 2, \dots, k$.

A distance matrix $\mathbf{D}_A = [d_{ij}]_{n \times n}$ can be used to store the point-to-point distances between the points in \mathbf{A} . Distance d_{ij} is the distance between point i and point j , and \mathbf{D}_A is a symmetric triangle matrix where the leading diagonals are all zero.

To reduce the columns (dimensions, k) of the matrix \mathbf{A} means to find a low-dimension matrix \mathbf{B} as shown in Figure 2.4. The distance matrix of \mathbf{B} is \mathbf{D}_B which should be as close to \mathbf{D}_A as possible and there are many ways to achieve this but in the classic MDS algorithm (Torgerson, 1958), a transition distance matrix \mathbf{Y} (containing \mathbf{D}_A) is introduced and a transition matrix \mathbf{Z} is constructed, as follows:

- (1) Construct transition matrices:

Based on \mathbf{D}_A , construct another distance matrix $\mathbf{Y} = [y_{ij}]_{n \times n} = [-\frac{1}{2} d_{ij}^2]$;

Based on \mathbf{Y} , construct $\mathbf{Z} = [z_{ij}]_{n \times n}$:

$$z_{ij} = y_{ij} - \bar{y}_i - \bar{y}_j + \bar{y}.$$

where the symbol “.” can be read as “all”; \bar{y}_i and \bar{y}_j are then the average values of all distance values in the i row and the j column, respectively.

- (2) Find lower dimensions and solve eigenvectors:

Solve the eigenvalues λ_i of the n^{th} -order algebraic equation $|\mathbf{Z} - \lambda_n E| = 0$ (E is a unit vector) and then rank the eigenvalues as $\lambda_1 \geq \lambda_2 \geq \dots \geq \lambda_n$. Find the smallest dimension k value as possible when the corresponding cumulative proportions, $m_{1,k}$ and $m_{2,k}$, are as large as possible, usually at least 85% (Ren and Yu, 2011: p.190):

$$m_{1,k} = \sum_{i=1}^k \lambda_i / \sum_{i=1}^n |\lambda_i|$$

$$m_{2,k} = \sum_{i=1}^k \lambda_i^2 / \sum_{i=1}^n \lambda_i^2$$

Usually, $\lambda_k \geq 0$. But if $\lambda_k < 0$, then a smaller k should be used.

Use B_1, B_2, \dots, B_n to represent the n eigenvectors of \mathbf{Z} . Solve the homogeneous linear equation set, $(\mathbf{Z} - \lambda_i E)B_i = 0$, in order to find B_i ; E is an $n \times n$ unit vector, which is a column-wise vector, i.e. $B_i = [b_1, b_2, \dots, b_n]^T$. Form an $n \times n$ matrix $\mathbf{B} = [B_1, B_2, \dots, B_n]$.

- (3) Forming the low-dimension matrix:

The low-dimension $\mathbf{B}_{n \times k}$ matrix is extracted from $\mathbf{B}_{n \times n}$ in which the row vectors, $B_i = [b_1, b_2, \dots, b_k]$, are the new points in the lower k -dimensional space.

Thus, the multidimensional space is reduced by MDS.

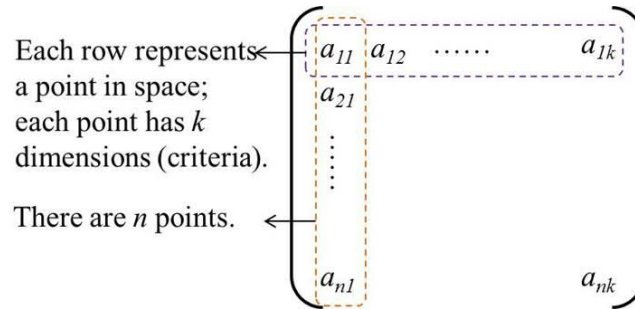

High dimensional space: a $n \times k$ vector matrix, $k \gg 3$

Iterative computations to fit the optimised configured matrix

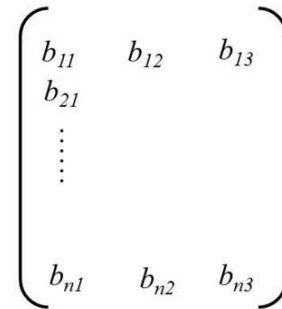

Low dimensional space, e.g. $k=3$

Figure 2.4 Illustration of reduction of dimensions in MDS:
 n -number of points; k -number of dimensions (or criteria)

The input data used in existing MDS-based patent mapping is in the form of expert's opinion, i.e., perceptual evaluations, which is the reason that the term "perceptual mapping" has also been used in MDS for describing the type of original data that is subjective (Hair, Tatham, and Black, 1995: p.484-555). This original data has high dimensionality and is termed as perceptual data, Pd ; and is transformed into 2D or 3D space of visual data, as Vd ; by a mapping rule, as $fd: Pd \rightarrow Vd$, which a premised topological relation that maintains the technical correlations, see Figure 2.5.

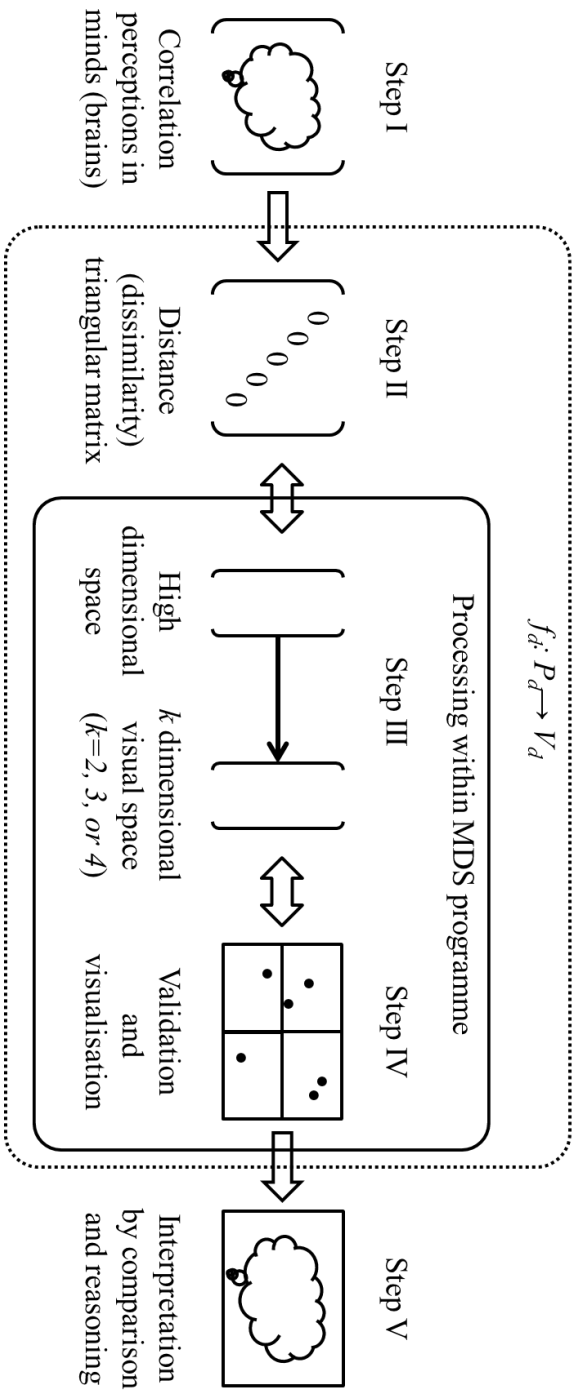

Figure 2.5 MDS-based patent mapping: from perceptual data (high dimensionality) to visual data (2D or 3D). f_d - mapping rules; P_d - perceptual data; V_d - visual data; Topological constants - technical correlations.

A limitation of existing MDS-based patent mapping is that it only deals with criteria-free data, which can result in obscurities in interpretations. For instance, if a score from 10 to 0 is given (from very similar 10 to not at all similar 0) to express perceptions of similarity between two patented designs (Chen and Chen, 2007), then this score is criteria-free because no specific criteria are identified. Criteria-based evaluations, e.g., Weight and Speed, provide clearer interpretations than criteria-free.

2.4 TRIZ and TRIZ Engineering Parameters

2.4.1 Core Idea of TRIZ

Based on inductions of historic patents and living innovation cases, TRIZ provides an analogical and critical way of thinking to formulate a linear solution to inventive problems by optimizing system resource applications and contradictory analyses, which avoids inertial thinking like try-fail-try or partial thinking. Here the structure of TRIZ is summarised and visualised in Figure 2.6.

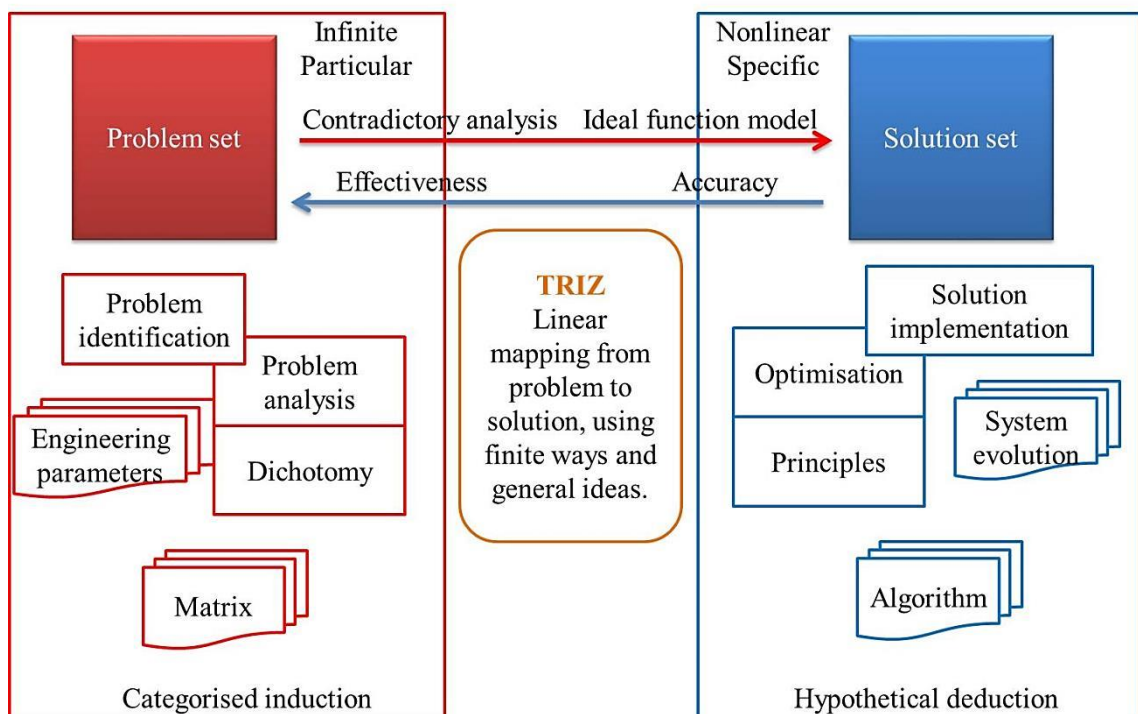

Figure 2.6 Summary of typical process of patent mapping.

Instead of searching large amount of patents, TRIZ shows the induction and understandings of technologies and innovative ideas for inventing based on the studies of nearly 200,000 patents. It is not a method to search patents, but a summary for generating inventive principles and infinite categories of contradictions of technical problems. While optimising system resources, TRIZ establishes the connections between chaotic numberless inventive problems and categorised finite solutions.

TRIZ is still being developed not only in mechanical engineering but also in other sciences such as bioengineering and social sciences like ecology. This gives the feasibility of method analogy from TRIZ to patent mapping. Similar endeavours have been done by previous researches such as BioTRIZ (Bogatyreva, Pahl, and Vincent, 2002) and TRIZ in Eco-innovation (Jones and Harrison, 2000).

2.4.2 TRIZ Engineering Parameters

In the TRIZ problem solving approach, every factor that affects a system is a parameter. There is a dependent relationship between the parameters of the system (Coelho, 2009). While some parameters have positive effects on other ones, some of them have negative effects. The parameters that have negative effects on other ones are said to be in contradiction. TRIZ is based on modifying the system to increase ideality by using a 39×39 contradiction matrix of engineering parameters. These parameters are widely acknowledged, still being developed, and are the focus of this research for specifying the inventive concept. The 39 general engineering parameters in the original version of TRIZ are briefly listed in Table C.1 with detailed explanations.

2.5 Comparison of Patent Mapping and TRIZ

Here, the comparison of TRIZ and patent mapping is presented in [Table 2.3](#).

Table 2.3 Comparison: TRIZ and Patent Mapping.

	TRIZ	Patent mapping
History	In 1956, TRIZ was published by G. Altshuller in Russia (Altshuller, 1999).	Japan Patent Office created the first patent map in 1968 (JPO, 2000).
Purpose	To solve technical problems for inventing.	To present correlations of information in patents.
General description	A toolbox for innovation, deriving from the studies on thousands of patented technologies, serves engineers and designers with guidelines and inspiring principles to solve inventive problems, avoiding trial-and-error thinking.	Visualised competitive intelligence (like maps), based on statistical analysis methods such as text mining, reveals correlations and trends of technologies, which are references for managers and lawyers to make decisions.
Logic	From induction (theory establishing) to deduction (application process).	From induction (theory establishing) to deduction (application process).
Main outcomes (contributions)	Technology evolution trend; Ideal final result; Contradictory analysis (matrix); and Substance-field analysis	Inventor ranking; Technology theme correlation; Opportunity discovering, risk assessment and early-warning; Trend forecasting; and Competitive strategies making

Previous research connecting TRIZ and patent classification ([Liang et al., 2009](#); [Li et al., 2014](#)) has been used to classify patents for inventive purposes and technical trends analysis but did not consider the inventive concept between patents for finding **obviousness** or invalidity. There are only a few research papers on potential patent infringement identification ([Cascini and Zini, 2008](#)) based on text mining methods. However, in most patent law systems there is a reliance on evaluation by human (i.e. skilled person, see [Appendix A: p.109-10](#)). Hence, while automatic text mining can reduce subjectivity, a method that accommodates human evaluations is more suitable for identifying patent claim conflicts in order to assess **obviousness**.

2.6 Other Relevant Methods about Patent and Innovation

2.6.1 QFD and F-Term

QFD is an inspiration and reference for designing a human evaluation process. QFD provides a procedure of opinion evaluation called “house of quality” (Figure 2.7), which is the core of QFD, a well-designed evaluation sheet for analysing and identifying demands from customers, product properties, i.e. engineering characteristics, and correlations between the human needs and technical solutions. There are four levels of correlations: strong, middle, weak, and none. Such an evaluation sheet gives an example for collecting data from expert’s opinion for patent information analysis.

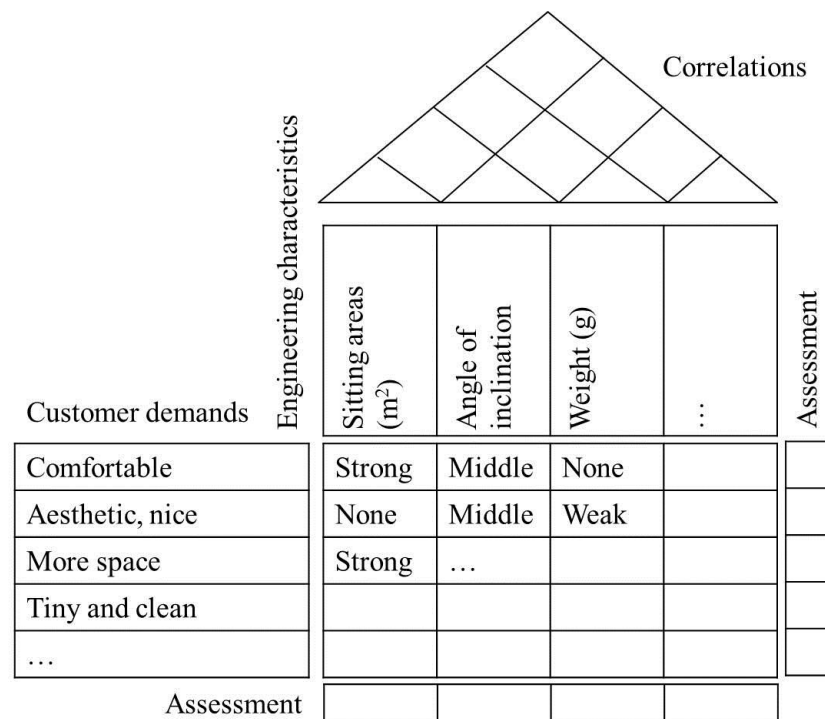

Figure 2.7 Demonstration of house of quality in QFD (Griffin and Somermeyer, 2007: p.54).

However, such an evaluation sheet is quite time-costly and boring for evaluators because, for each evaluation case, engineering characteristics are produced according to the customers’ demands which may usually be twice numbers of that of the demands, or more times. That makes the evaluation sheet, i.e. the matrix very big, sometimes more

than 1000 blanks. If each blank is remarked with the four options, then discussions for each blank will be approximately 3 to 10 minutes (Griffin and Somermeyer, 2007: p.47).

F-term is another inspiration for designing new methods for evaluating patent claim conflicts, especially in interpreting the inventive concept. F-term, as mentioned in Chapter 1, is a classification theory for patents established by the JPO. It provides several description angles or aspects, i.e. multi-dimensional viewpoints, to classify an invention, including applications, functions, structures, materials, and production processes (Iwasaki, 2008). It is the specification based on International Patent Classification (IPC) in order to precisely classify and retrieve patents in JPO. The main advantage of the multi-dimensional viewpoints is that it fits the multiple needs of patent retrieval by increasing the keywords in search. There are around 340,000 items in F-term system. Each is a combination including theme code, viewpoints, and figures.

2.6.2 Life Cycles of Innovation and Patent

Previous methods studied on the life cycles of innovations and patents are listed here:

(1) Typical stages of innovation are demonstrated by the anatomy of innovation (Ceserani and Greatwood, 1995: p.23, see Figure 2.8), which reveals that innovation is a fluctuation curve. Some stages in the curve may repeat in reality. Although the x-axis represents time, this curve is a qualitative analysis and a general representative process of innovation process. The curve is not used for exact prediction or real analysis of inventors' attitudes (y-axis) or expectations for specific cases. Again, the value of this curve is the qualitative appreciation that fluctuation means that innovation is a dialectical process including position, negation, and negation of negation; and

(2) The studies of patent life cycle (Griffin and Somermeyer, 2007) for process management (Figure 2.9). This life cycle mainly describes the application process in a patent lifespan. Patent life cycles are difficult to model yet they are very important in patent litigation and infringement risk analysis (Smith and Parr, 2005).

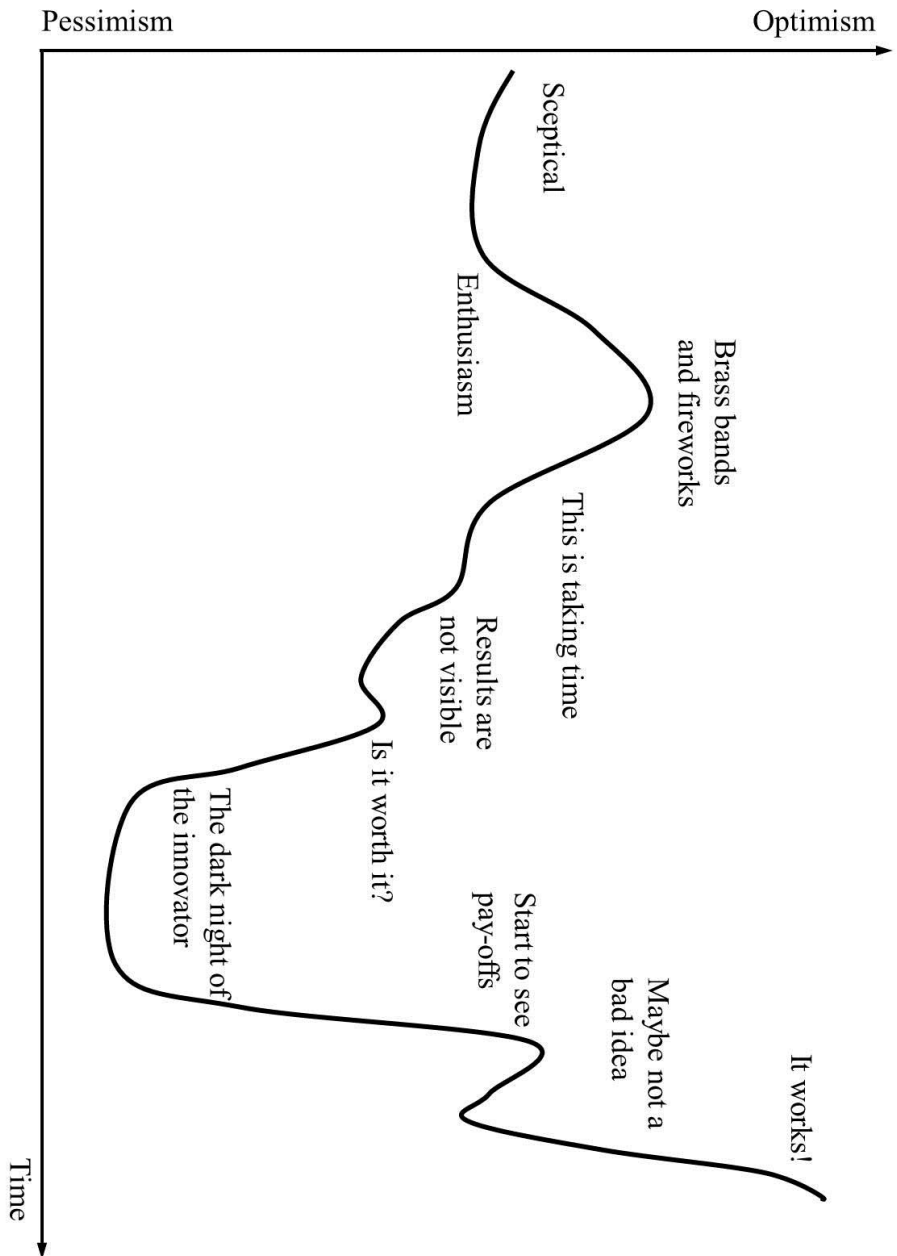

Figure 2.8 Anatomy of innovation (Ceserani and Greatwood, 1995: p.23).

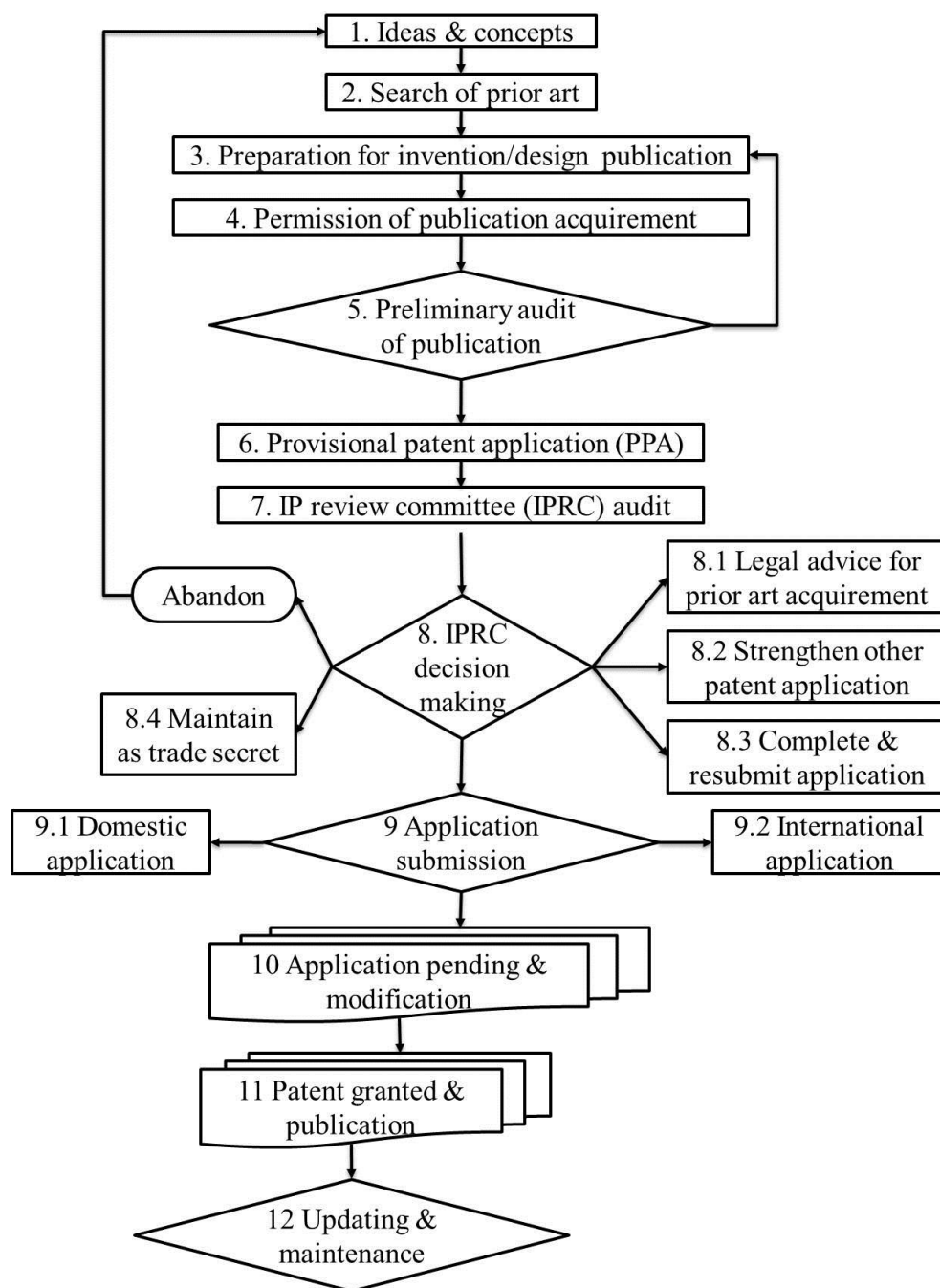

Figure 2.9 Patent lifecycle (selected from Griffin and Somermeyer, 2007: p.260).

These life cycle models are useful for understanding the background knowledge of patents and innovations, particularly for rethinking the premise of the research problem (see discussions in [Chapter 6](#)) and developing patent valuation methods ([Smith and Parr, 2005](#)).

2.7 Summary of Chapter 2

The task of literature review is not to find flaws within the existing methods but to find links between them, and combine them, thereby to build up a holistic new method to solve problems which neither patent mapping nor TRIZ had solved, i.e. evaluating conflicts between patent claims (assessing **obviousness**). According to the literature, no specific method for interpreting the inventive concept has been found. This is the opportunity for a new method, and to create such a new method, patent mapping and TRIZ are combined.

From the literature review of patent mapping and TRIZ, the research aim has been confirmed again. Patent mapping and TRIZ are typical and mature methods and theories in patent informatics and innovation. In summary, the core idea of patent mapping is to transform structured texts in patents into mathematical data so that data correlations can be processed by computer programme; TRIZ builds the contradiction matrix to link special inventive problems with potential solutions. The common point between these methods is that they are both designed mechanisms for transforming complex and systematic relationship identification problems into simple and specific attribution identification tasks.

Chapter 3 Method

3.1 Introduction to Chapter 3

Chapter 3 presents a new model for evaluating conflicts between patent claims. There are two parts in the chapter: firstly, designing the elements of the inventive concept, which is the basis of modelling Criteria-Based Patent Mapping; and secondly, realising the new model, i.e. designing a new method, which is TRIZ-Led Patent Mapping.

3.2 Criteria-Based Patent Mapping

3.2.1 Definition of Elements

The elements of the inventive concept are conceptual units composing inventive concept (see the definition of the inventive concept in [Appendix A, p.108](#)), defined as below:

- (1) They are attributes representing a patent claim. They are sub-concept or lower concept of the inventive concept. They are the simplest description (i.e. describing from only one category) of an existing man-made matter; and
- (2) They are Common General Knowledge (CGK) ([Appendix A, p.110](#)) of a certain technical field, e.g. mechanical engineering parameters.

The logical relationship between the elements of the inventive concept and other relevant concepts in contexts of **obviousness** is shown in [Figure 3.1](#): the solid-lines represent the scope of concepts that are able to be solidified, i.e. tangible concepts or attributes, such as elements and claims; meantime, the dash-lines indicate the intangible concepts or relationship, which is the inventive concept.

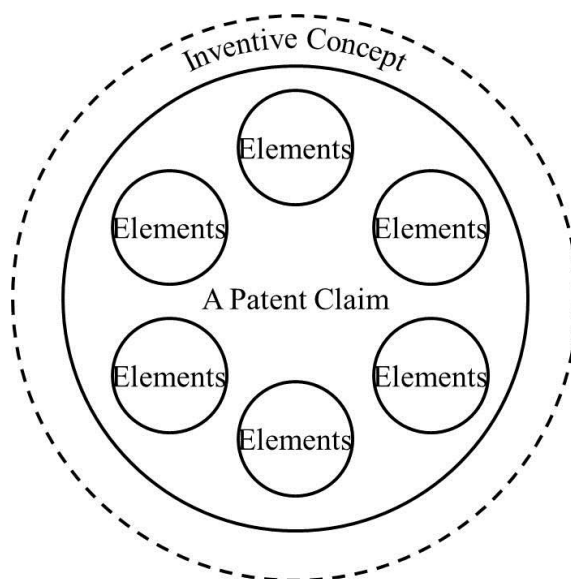

Figure 3.1 Elements of inventive concept: solid line is the boundary of claim construction while dash line shows the boundary of inventive concept. The scope narrows down from the inventive concept to a patent claim and elements.

The elements of the inventive concept compose many technical characteristics or features. To classify the elements six categories (Table 3.1), inspired by Kant’s category (Kant, 1781), are highlighted in this model.

Table 3.1 Composition: category of elements (inspired by Kant’s category).

Categories	e.g.
(1) Quality v Quantity	vector (angles) v scalar (figures)
(2) Reality v Rationality	dynamic (unbalanced) v stable (balanced)
(3) Certainty v Possibility	absolute coordinate v relative distance
(4) Form v Content	cycle (period) v rotation (time)
(5) Phenomenon v Essence	force and field v properties of matters
(6) Part v Whole	structure (human) v function (environment)

Each category is a high concept, containing specific technical characteristics, e.g. the element of quantity can be “mass” and “length”, which are lower concepts. Reviewing

the literature, the TRIZ engineering parameters are the most closed equivalence to the descriptions of the inventive concept.

3.2.2 Evaluation of States

The elements in patent claims are evaluated by human evaluators through evaluation sheet by a binary choice: states of active or inactive, which enable different elements to be comparable, i.e. under the same dimension of states. For instance, if a patent claim from patent A1 is stated as: "... The angle between the planes is around 40° to 60°..." The elements "angle" and "figure" are contained in the patent claim A1, which will be evaluated as active elements; other elements (e.g. time) not mentioned in the claim, are seen as inactive elements. Similarly, claim B1 and claim C1, as examples, are evaluated. The form of evaluation sheet is designed and displayed in [Table 3.2](#). Thus, each evaluated patent claim can be seen as an ordered scale, i.e. a vector, e.g. claim A1 is seen as (1, 0, 1); and lots of evaluated claims can be seen as a matrix.

Table 3.2 Evaluation: states of elements.

Patent claim	State of element (1-active, 0-inactive)			Result
	e1 (angle)	e2 (time)	e3 (figure)	
A1	1	0	1	(1, 0, 1)
B1	0	0	1	(0, 0, 1)
C1	0	1	0	(0, 1, 0)

In addition, as a matter exists, it must reveal at least one active element or it won't be perceived as an existing matter.

3.2.3 Calculation of Similarity

By evaluating elements, the question of comparing relationship between patent claims has been hereby transformed into calculating distance or dissimilarity between vectors. Many mathematical ways to calculate distance or dissimilarity of data are shown in multivariate analysis ([Ren and Yu, 2011: p.60-9](#)). Nevertheless, the definition of

differences should consider real evaluation process of claim conflicts. As the real process is identifying a contradiction of similarity, i.e. seeking substantial similarity while admitting phenomenal differences, the definition of calculation should reveal such a contradiction. Thereby, this research introduces two kinds of similarity:

(1) Absolute similarity: the relationship of sharing the same active elements between patent claims. Number of common active elements represents substantial similarity, e.g. see [Table 3.2](#), claim B1 and A1 are more similar than that of C1 in terms of absolute similarity, because B1 and A1 share one common active element while B1 and C1 share zero; and

(2) Relative similarity: the relationship of active elements in each patent claim. Number of all active elements of each claim represents phenomenal differences between each claim, e.g. see [Table 3.2](#), claim B1 and C1 both have one active element, meaning they are more similar in terms of relative similarity than that of A1 (having two active elements).

Hence, similarity between patent claims is defined as dividing the number of common active elements between two claims by the number of total active elements of both. Such a definition interprets similarity between two claims as seeking absolute similarity from relative similarity, which matches the essential meaning of conflict (**obviousness**). This is the reason that the model is able to represent **obviousness** and **non-obviousness**. The calculation function is built and shown below.

3.2.4 Visualisation of Vectors

By multivariate analysis such as MDS, vectors can be transformed into lower-dimensional, e.g. points in a 2D picture. Sets of vectors are corresponding to clustering of points. All of this visualisation process can be integrated completely with the benefit of software.

3.2.5 Interpretation of Points

The modelling is a typical mathematical process of problem transformation (finding equivalence) and symbolic-graphic combination (establishing mapping) , from where the logical path is extracted below:

- (1) Elements \leftrightarrow vectors \leftrightarrow dissimilarities \leftrightarrow distances;
- (2) High dimensional vectors \rightarrow 3D matrix; and
- (3) 3D matrix \leftrightarrow points in graphs:
 - (a) Dissimilar vectors \leftrightarrow solitary points; and
 - (b) Similar vectors \leftrightarrow clustered (closed or overlapped) points.

Solitary points, used for representing non-obvious claims, i.e. non-conflict claims in maps; clustering points are potentially conflict claims. Admittedly, solitary and clustering are still partial not holistic assessment. However, partial **obviousness** is still a necessary condition in assessment, which is the reason that patent offices and patent attorneys still offer reports of claim comparison. As the whole model began from the elements, it is, therefore, named as “Criteria-Based” patent mapping.

3.3 TRIZ-Led Patent Mapping

3.3.1 Combination of TRIZ and Patent Mapping

The combined method, TRIZ-Led Patent Mapping, reveals conflicts and solitary patent claims, i.e. probable **obviousness** and **non-obviousness** between patent claims. The TRIZ general engineering parameters are a set of high-level technical descriptors for defining the categories of elements of the inventive concept, derived from the study of patent literature (Bogatyreva, Pahl, and Vincent, 2002; Mann, 2003). The combined method, TRIZ-Led Patent Mapping, reveals potential risks of conflicts between patent claims in competing patents. If a technical feature in one patent is in conflict with the technical feature in another patent, then this conflict will also exist at a higher technical

level (category of element). Therefore, comparing high-level TRIZ engineering parameters instead of low-level technical features will be a more efficient means of effective comparison of patents. As patent claims are based on low-level technical features then they can be transformed into high-level TRIZ engineering parameters in order to identify patent conflicts.

3.3.2 Framework of New Method

According to the new model, there are three parts in the framework of the new method, the logical flow of which can be drawn in a flow chart in [Figure 3.2](#):

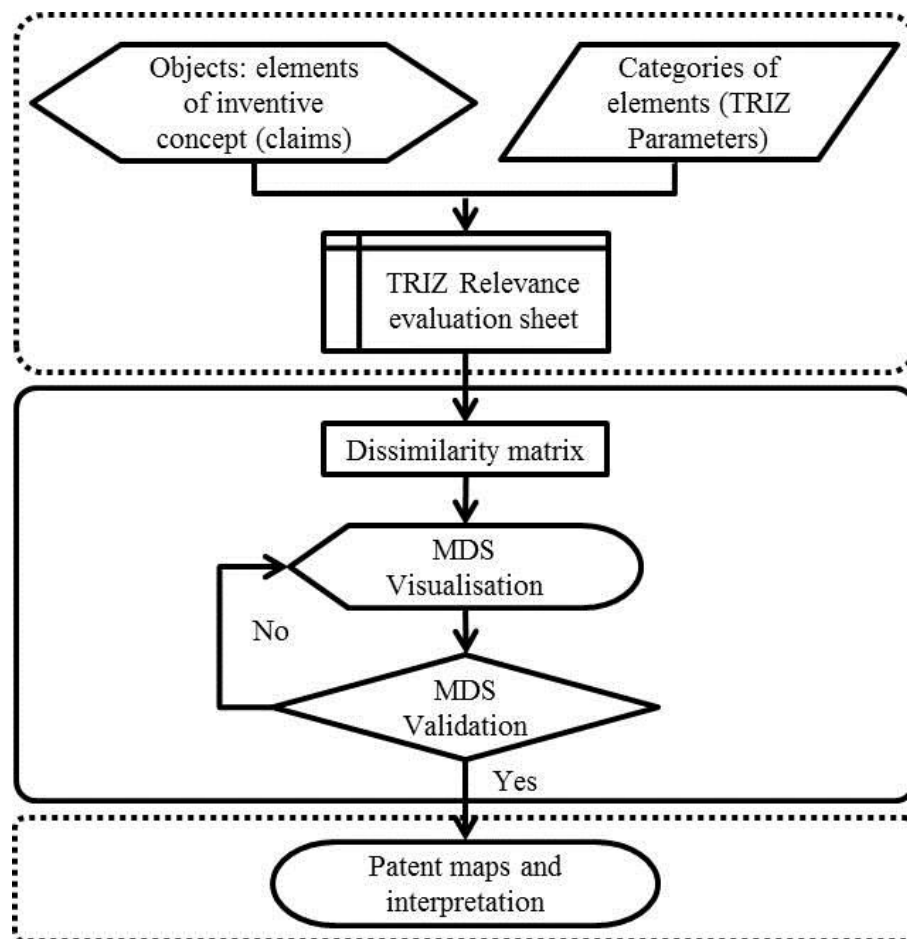

Figure 3.2 Framework of TRIZ-Led Patent Mapping.

- (1) Evaluation: TRIZ parameters are used as evaluation criteria meanwhile house of quality in QFD is the example for forming evaluation sheet. Evaluation results are collected by focus groups as primary data;
- (2) Calculation and visualisation: MDS-based patent mapping is adopted to obtain mapping results; and
- (3) Interpretation: identifying conflict and non-conflict claims.

3.3.3 Evaluation Criteria

The original 39 TRIZ parameters are adopted to form the categories of elements of the inventive concept, which are used as evaluation criteria. In practice, too many of these parameters will result in difficulties for data collection and calculations; whereas most problems only need to employ a subset of the 39 parameters in order to improve the evaluation efficiency. The 39 parameters are refined to a smaller set according to their logical associations with general physical or operational categories, such as combining those that refer to weight, length, volume, stability, force, energy/power, uncertainty, accuracy, moving, as shown in [Figure 3.3](#). Also, two parameters (30 and 31) were removed as they only apply to rare cases.

The original parameter 1 and 2 are both related to the physical category Weight; the original 7 and 8 relate to Volume. These four are thus combined into one group, as the refined parameter 3, called Volume and Weight. Similarly, original 3, 4, 5, and 6 are combined into new refined parameter 4, Length and Area. Another category of combination is about operational matters, whereby original parameters 27, 28 and 29 are combined into new refined parameter 8 (Accuracy, Precision and Reliability); original 32, 33 and 34 are combined into new parameter 9 (Ease of Manufacture, Operation or Repair); 38 and 39 are combined into new refined parameter 11 (Productivity and Automation).

Some original parameters are given by a new name or expanded name, such as the original 17 (Temperature) becomes new refined parameter 6 (Field) because this more general term can then include other fields such as Magnetic. Similarly original

parameters 18, 23, 24 and others are transformed into a more general refined parameter for inclusivity. Very unique parameters are kept the same, e.g. 26 (Quantity) and 35 (Adaptability or Versatility).

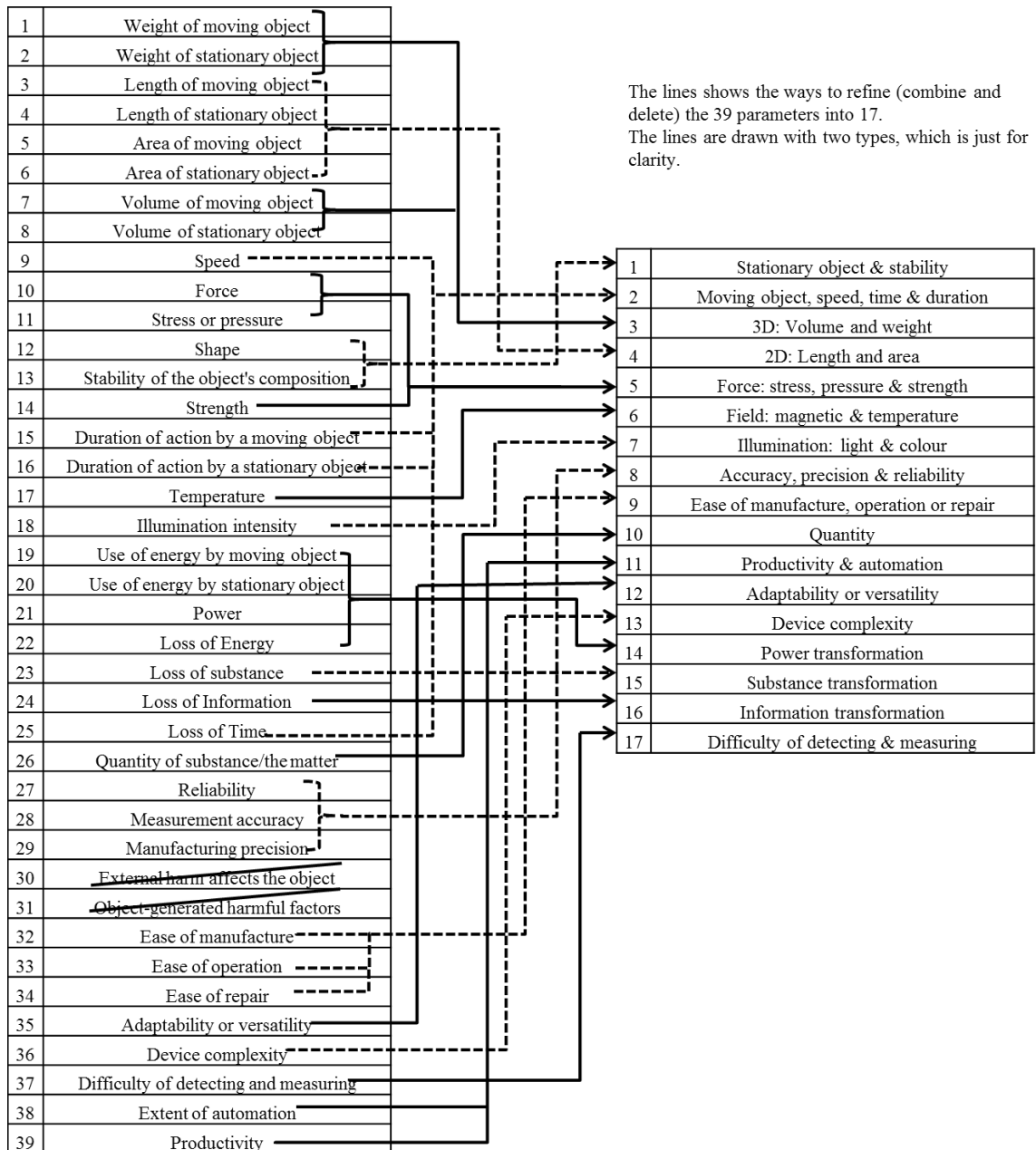

Figure 3.3 Refining engineering parameters in TRIZ: from 39 to 17.

Further refinement of the 17 parameter set above, omitted parameter 16 (Information) in order to reflect a focus on design and manufacture; Parameter 5 (Force) and parameter 6 (Field) combine into one parameter because they are similar; Parameters 14 (Power

Transformation) and 15 (Substance Transformation) are simplified to a general Transformation. Hence, there is a refined 12 criteria set for evaluation (Figure 3.4).

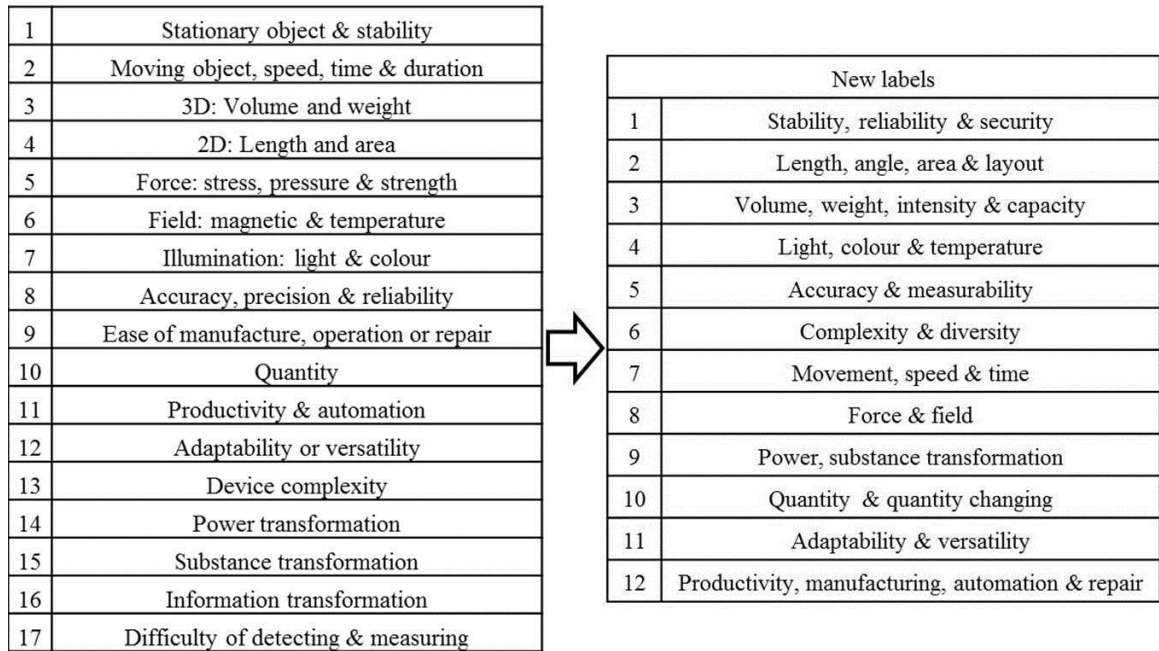

Figure 3.4 Refining engineering parameters in TRIZ: from 17 to 12.

The case study on metal enclosure patents was assessed by focus groups (see s.6.8.7 for more details of arrangements of focus groups) in order to assess the consistency of results with regards to three sets of evaluation criteria (39, 17, and 12 parameters, see Figure D.1 and Table E.1) through using the Cronbach's method (Cronbach, 1951). The Cronbach's Alpha value is 0.875 (Figure 3.5), which is better than the normally acceptable value, 0.7, and just under the value of 0.9 that is normally considered to be "very good" (Kline, 2000: p.13).

Cronbach's Alpha	Cronbach's Alpha Based on Standardized Items	N of Items
0.875	0.906	28

**Figure 3.5 Reliability statistics results from SPSS:
Consistency between three sets of criteria: 39, 17 and 12 parameters.**

Therefore, the refined set of evaluation criteria consisting of 12 elements (12 refined TRIZ general engineering parameters) is adopted as the initial set of evaluation criteria for TRIZ-Led Patent Mapping (see the validity test below). The sets of evaluation criteria having different numbers of (refined) TRIZ general engineering parameters are symbolised as E_k , e.g. E_{12} , means the criteria set adopting 12 elements (i.e., 12 refined TRIZ general engineering parameters).

3.3.4 Evaluation Sheet

An evaluation sheet is introduced (Figure 3.6) in order to identify the elements of the inventive concept in patent claims that can be linked to the TRIZ parameters which are adopted as categories of elements. Three types of items are entered in this matrix with reference to patent claims in conjunction with patent diagrams:

- (1) Left column: patent claims;
- (2) Top row: evaluation criteria. In the E_{12} criteria set, the criteria include Stability, Length, Volume, Light, Accuracy, Complexity, Movement, Force, Power transformation, Quantity, Adaptability, and Productivity; and
- (3) A marker is placed wherever a claim has relevance to a criterion.

	E_1	E_2	...	E_k
C_1				
C_2				
\vdots				
C_n				○

Figure 3.6 Explanation of an evaluation sheet.

As there are many kinds of inventions, e.g. mechanical inventions, chemical inventions, and biological inventions, there are different kinds of criteria. The TRIZ parameters are one specific kind of criteria used only for mechanical inventions.

The evaluation sheets are offered to evaluators in focus group, who are asked to answer this question below:

“Does the claim describe something relevant with the elements?”

If “Yes”, then make a mark there; if “No”, then leave the place blank, i.e. every element (parameter) is equal to each other and assessment of active elements is a binary choice, not a weighting evaluation. Because assessing **obviousness** is clarified as a qualitative not quantitative test in *Molnlycke AB v Procter & Gamble Ltd* [1994] RPC 49 p.112, meaning scoring or weighting each criterion rather than the binary choice is not legally admissible.

3.3.5 Dissimilarity Function

If two claims, C_i and C_j (i and j represent order numbers of claims) share m_{ij} common TRIZ parameters, and the total number of TRIZ parameters related to the two claims is $k_i + k_j$, then the similarity between claim i and claim j , s_{ij} , can be calculated by equation (1).

$$s_{ij} = \frac{2 m_{ij}}{k_i + k_j} \quad (1)$$

The result is 1 if two claims have exactly the same correlations with TRIZ parameters; and the result is 0 if there are no TRIZ parameters common to both. Such ratio reflects the proportion of absolute similarity (m) from relative similarity ($\sum k$).

Similarity and dissimilarity are a contradiction in claim comparison, which, mathematically, means that the proportion of dissimilarity is the opposite part of similarity, i.e. the converse of the similarity ratio. Thus, the TRIZ relevance matrix is

then transformed into a dissimilarity matrix by using equation (2), where, d_{ij} , represents dissimilarity between claim i and claim j .

$$d_{ij} = 1 - s_{ij} \quad (2)$$

In addition, using dissimilarity instead of similarity is for mathematical consideration for constructing distance matrix in order to guarantee the input matrix processed in MDS to be a triangle matrix with 0 values in the diagonal line (from left top to right bottom). Using this type of matrix as the input data is called the metric MDS ([Hair, 1995: p.499](#); [Ren and Yu, 2011: p.302-11](#)).

[Figure 3.7](#) shows how the TRIZ relevance matrix is used to calculate the similarity, which is eventually recorded in a triangular matrix of dissimilarity calculation results.

An example of the evaluation sheet

		Elements of criteria: refined TRIZ parameters					k
		E_1	E_2	E_3	E_4	E_5	
Patent claims	C_1	0	0	0		0	4
	C_2	0			0	0	3
	C_3		0	0	0		3
	C_4				0		1
	C_5		0	0		0	3



Similarity calculation

Claim	Similarity	Interpretation
C_1-C_2	0.57	Taking C_1 for instance, C_5 has the most similarities with C_1 among all the five features while C_4 is totally different from C_1 . C_2 and C_3 have the same similarity as C_1 but these two are not very similar to each other (0.33).
C_1-C_3	0.57	
C_1-C_4	0	
C_1-C_5	0.86	
C_2-C_3	0.33	
C_2-C_4	0.5	
C_2-C_5	0.33	
C_3-C_4	0.5	
C_3-C_5	0.67	
C_4-C_5	0	



Dissimilarity calculation

	E_1	E_2	E_3	E_4	E_5
C_1	0				
C_2	0.43	0			
C_3	0.43	0.67	0		
C_4	1	0.5	0.5	0	
C_5	0.14	0.67	0.33	1	0

Triangle symmetric matrix

Figure 3.7 Relevance evaluation, similarity and dissimilarity calculation.

3.3.6 Visualisation by SPSS

The ratio values in the dissimilarity matrix represent the evaluators' perceptions of conflicts between patent claims. The matrix data is put into SPSS (a statistics software, SPSS 18.02, 2013) in order to produce the patent maps. We choose 3D mapping, not 2D, because 3D visualisations remain more information (one more dimension) than 2D ones, e.g. sometimes, two points are observed as a cluster in a 2D map while having a clear distance between each other in the 3D map, which means 3D mapping is a better way to configure correlations of the original input data.

3.3.7 Map Interpretation

When interpreting the patent map in [Figure 3.8](#), the axes are only used for establishing a space of dissimilarity between patent claims by MDS.

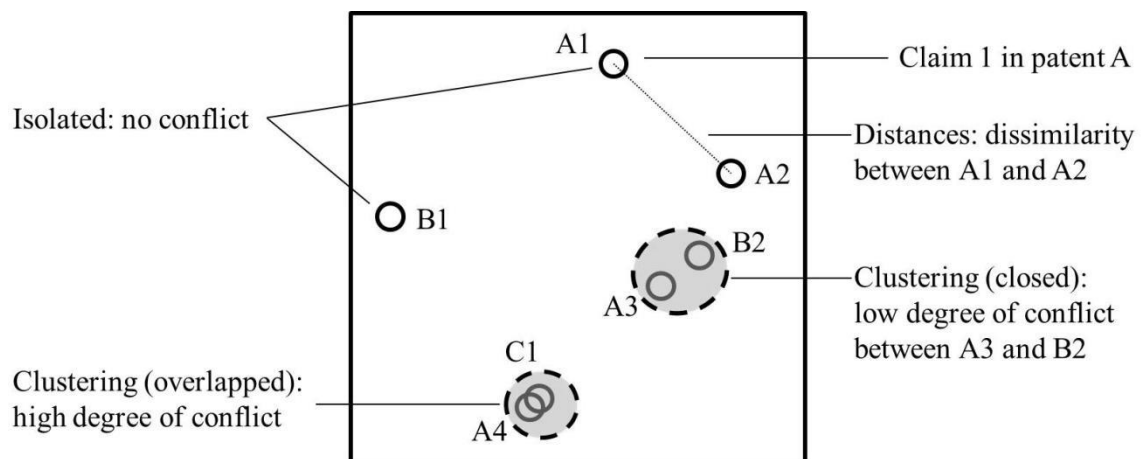

Figure 3.8 Sample of a mapping result of TRIZ-Led Patent Mapping. The distances between points represent dissimilarity calculated by criteria-based evaluations. Axes have no real meanings but represent scales to measuring distances.

Random initialisation of the MDS process means that the initial point positioning in the patent map is arbitrary, as it is the clustering of points that matters in judging whether claims are similar or not. Distances between points are akin to correlations between the patent claims but the space between points and the axes have no physical or useful meaning.

3.3.8 Programming by MATLAB

The algorithm has been programmed in MATLAB and developed to integrate the time-consuming evaluation procedure into an efficient process, as well as saving the time of similarity calculations. The main part of the code is shown below:

```
clear
close all
files = dir('*.xlsx');
number_of_files = length(files);
for k = 1:number_of_files
    clear cc a b e d M
    M=xlsread(FileName,1);
    [r c]=size(M);
    for i=1:r
        cc(i)=sum(M(i,:));
    end
    for i=1:r
        a=find(M(i,)==0);
        b=size(a);
        for j=1:b(2)
            M(i,a(j))=NaN;
        end
    end
    for i=1:r
        for j=1:r
            d(i,j)=sum(M(i,)==M(j,:));
        end
    end
    for i=1:r
        for j=1:r
            e(i,j)=1-2*d(i,j)/(cc(i)+cc(j));
        end
    end
    xlswrite([FileName(1:end-5) '_C-Matrix.xlsx'],e);
end
```

3.4 Summary of Chapter 3

This chapter interprets and argues the rationality of “criteria” basis including the new model and its realisation, i.e. the new method. As “The aim of science is not to open the door to infinite wisdom, but to set a limit to infinite error”, the validation of the new method is crucial, which, represented by values of “precision”, is shown in the next chapter.

Chapter 4 Validation of Method

4.1 Introduction to Chapter 4

Chapter 4 shows the validation process of TRIZ-Led Patent Mapping based on the study of Case 1, in which the target patent contains a mechanical aircraft seat. E_{12} is used as the initial testing criteria set. Although different cases have specific situations, the process of validation is the same, which contains two types of tests:

- (1) A test of reliability that verifies the consistency of similarity calculations between different evaluators; and
- (2) A combined test of sensitivity and specificity that assesses the validity of different sets of evaluation criteria (criteria sets).

4.2 Case 1: Adjustable Aircraft Seat

4.2.1 Patents and Maps

The target patent in Case 1 is about the adjustable aircraft seat. The reason of selecting this case is that it is a newly-settled, well-known case. The patents involved are EP1495908A1, GB2326824A, and EP1211176B1, which were respectively marked as A, B, and C. In this case, all these patents contain aircraft seats and seat layout pattern designs. The focuses of the claim conflict were mainly about the flip-over part of the mechanical seats and layout patterns of the seats (*Virgin v Zodiac* [2009] EWCA Civ 1062). The drawing in the target patent is displayed as following (Figure 4.1):

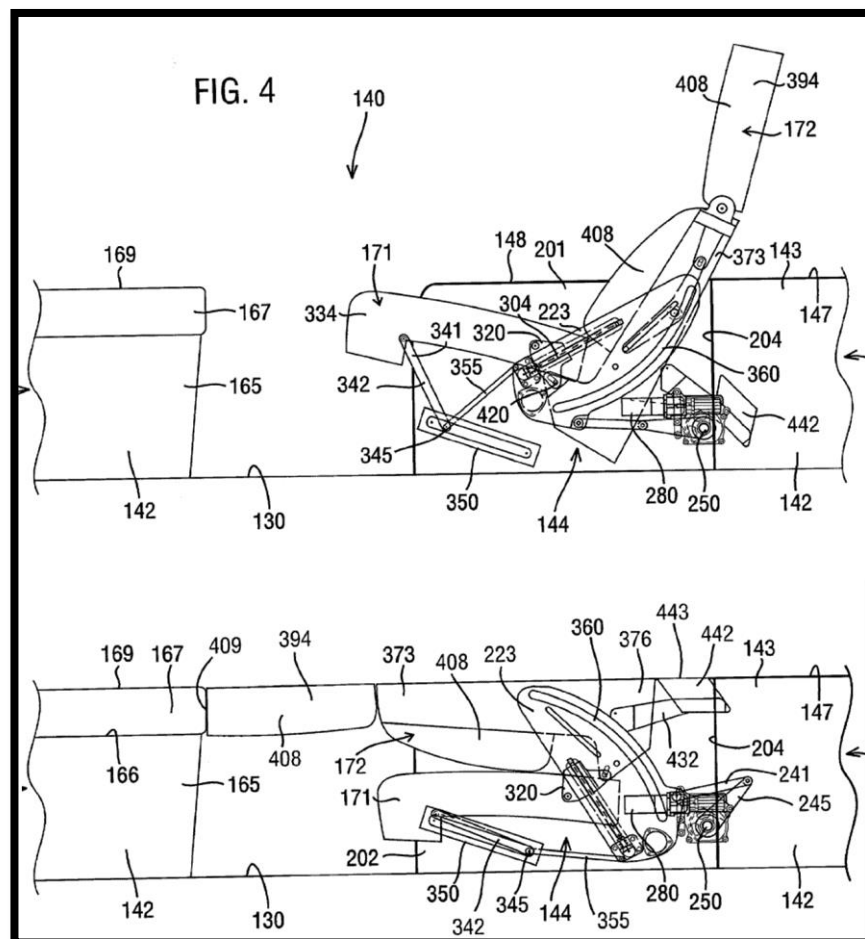

Figure 4.1 Invention of target patent (EP1495908A1) in Case 1: adjustable aircraft seat.

The interface of the programme (designed by the author, Feifei Jiao and Chao Liu) used in this case study is shown in Figure 4.2. Using the programmed calculation, it was much faster than hand calculations. An information sheet of how to use the interface was provided to the evaluators. Certainly, if printed evaluation sheets are convenient to carry out, then it is not necessary to use the computer interface.

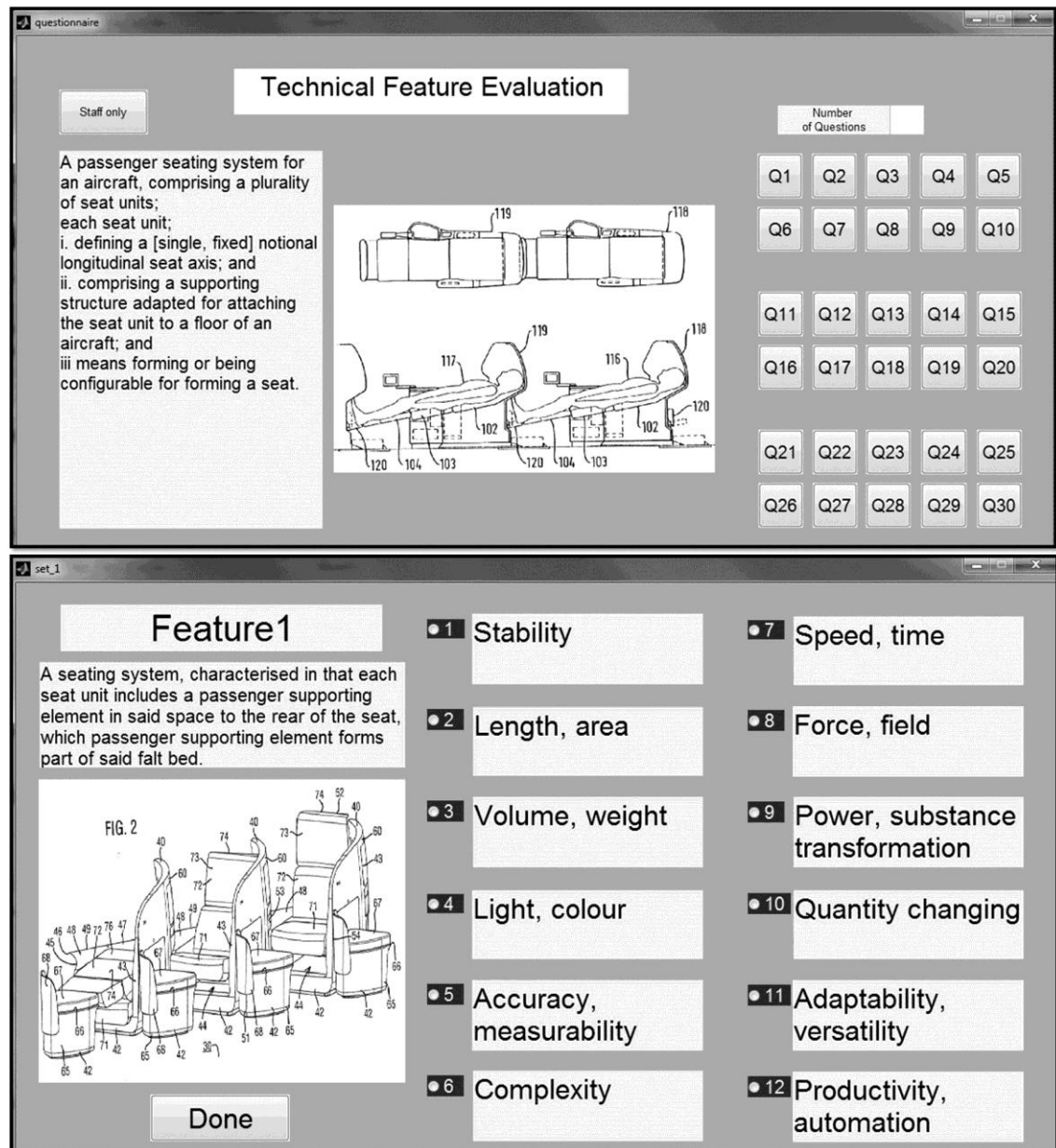

Figure 4.2 User interface (sample) for Case 1: using E_{12} .

The evaluation result is presented in [Table G.1](#), and the mapping results are displayed in [Figure 4.3](#).

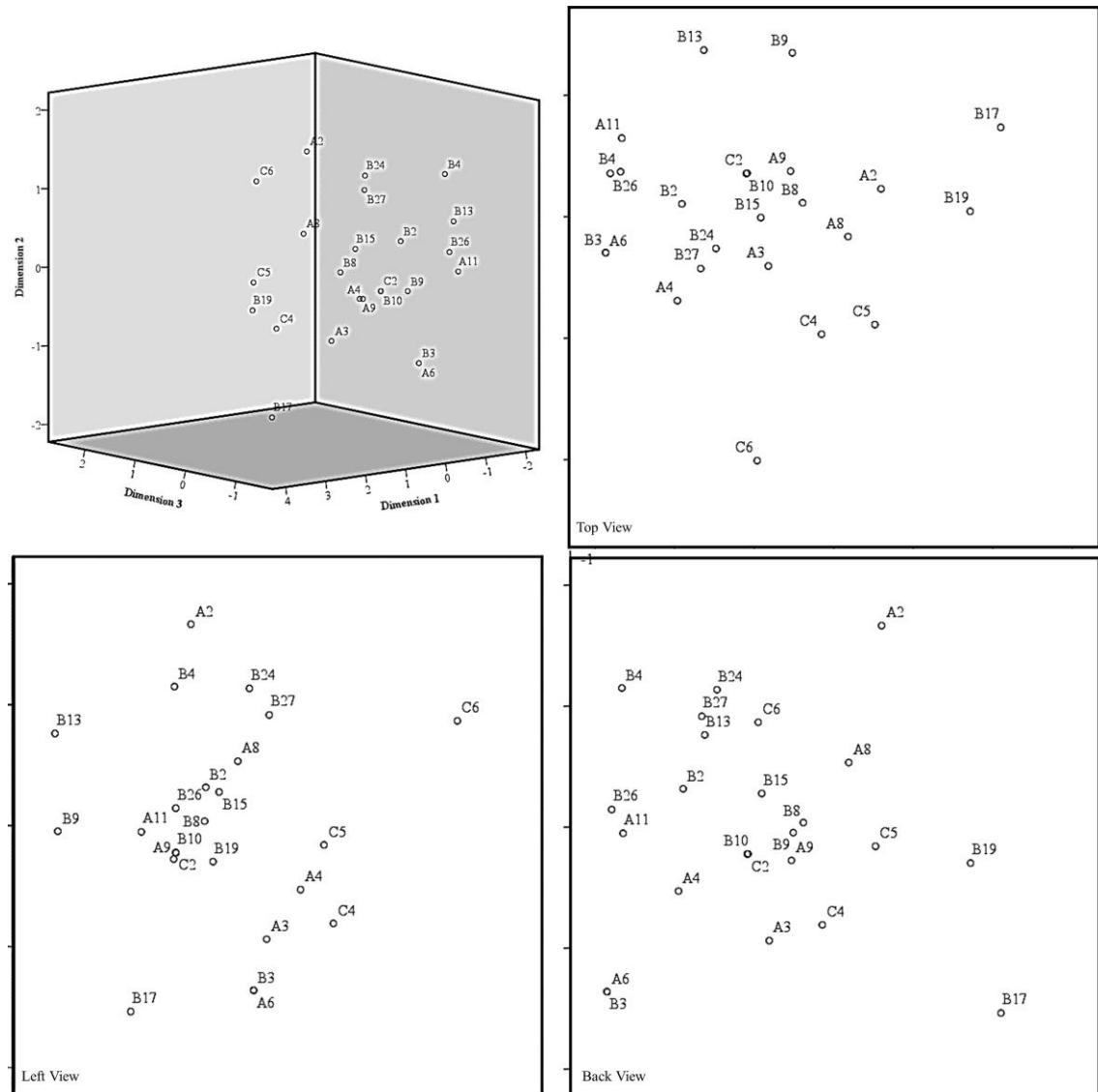

Figure 4.3 TRIZ-Led Patent Mapping of the aircraft seat case: using E_{12} (E_{12} was firstly adopted. Then newly-developed criteria sets were used which are shown in [s.4.4.4](#)). (Stress=0.15 and RSQ=0.91, from SPSS; an enlarged map is shown below)

Remark of the maps above: in this case, A1 is an independent claim so it is ignored in the evaluation but included in the identification of potential conflict by virtue of the claims that depend on it, i.e. A6, which is identified as a conflict claim. It is necessary

to remind that independent claim and dependent claim have a part-whole relationship, meaning partial conflict only results in potential whole conflict.

4.2.2 Interpretation of Mapping Results

Interpretation of the TRIZ-Led Patent Mapping results of [Figure 4.4](#) follows five steps:

- (1) Identify conflict claims in mapping results. The clustering claims were observed and marked by circles, indicating that the conflicts exist between these claims A6, B3; A11, B26; and A9, B8, B10, B15, C2. As a result, all the suspect conflict claims in the target patent are: A1, A6, A9, and A11;

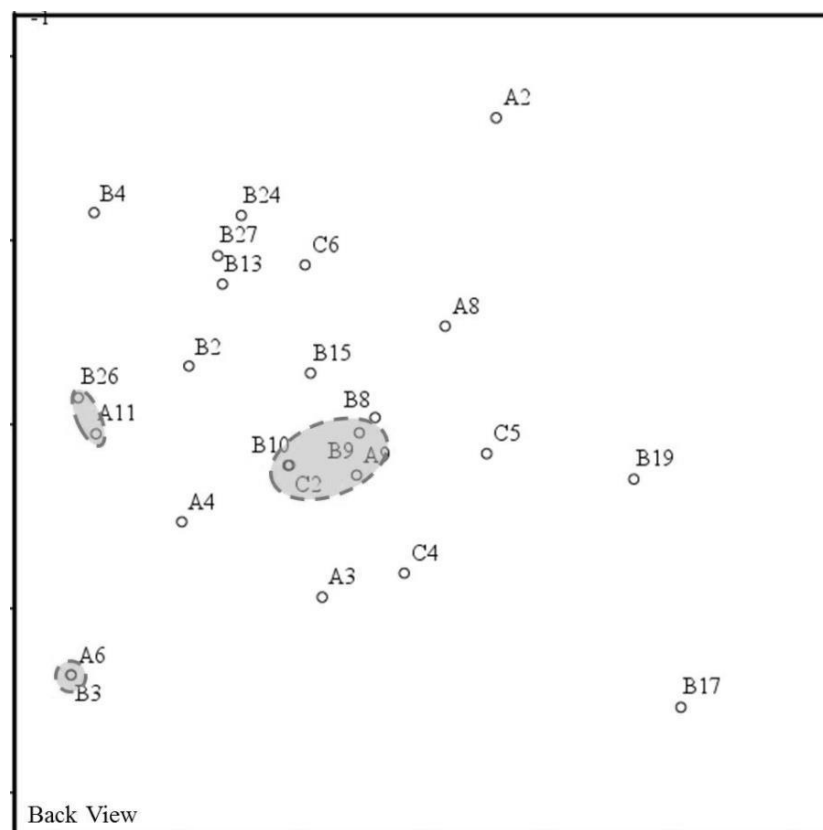

Figure 4.4 Observing clustering in 3D maps: using E_{12} .

- (2) Compare mapping results with those in legal judgments. Checking the court judgments in the lawsuits, patent A was accused of revocation because of partial invalidity—its claims may partially interfere with the claims in B and C

(see details in the above paragraph). In the judgment, A1 and A9 were particularly emphasised as the controversial claims. A1 was an independent claim comprising all its other claims. The mapping results reveal the specific conflict claims depended on A1: A6, A8 and A11; meanwhile, A9 was emphasised particularly;

(3) Assess the sensitivity and specificity of the criteria set used (E_{12}). The value of sensitivity and the specificity are calculated; and

(4) Repeat the steps above for comparing the mapping results with the results from the EPO search report.

4.2.3 Summary of Case 1

The summary of Case 1 is actually the reliability and validity tests of it, shown below. In addition, three points are remarked here:

(1) The patent granted dates have not been used in this method because the comparison between technical features in claims is the main concern; and

(2) The descriptions and drawings in the patents are necessary for explanations of claims. This is considered in the designed user interface ([Figure 4.2](#)) or simply introduced in the focus group; and

(3) The target patent A in this case has an amended version after the invalidity litigation, which is published and also considered within the case study, shown in [Chapter 5](#).

4.3 Reliability Test

4.3.1 Consistency between Evaluators

Reliability generally refers to consistent results in repeated tests (Golafshani, 2003). Consistency was tested via focus groups using the evaluation sheet (Table F.1). Two groups contained four different evaluators in each. There were slight differences of evaluation results between individual evaluators. But after intra-group discussions, no significant difference was found between the evaluation results of the two groups. The tests were repeated three times in different days. Consistency between group evaluations was confirmed between group evaluations.

4.3.2 Consistency over Time

The consistency over time was tested through one evaluator repeating the evaluation in the next day. No difference was found.

4.3.3 Consistency between Criteria Sets

The consistency of the evaluation results between using different criteria sets has been verified through Cronbach's method.

4.4 Validity Test

4.4.1 Combined Tests of Sensitivity and Specificity

The meaning of validity usually depends upon a researcher's understanding of the specific problem (Golafshani, 2003). The validity of this new method was checked by comparing mapping results with actual legal judgments through combined tests of sensitivity and specificity, which can be formed into the cross-comparison table shown in Table 4.1. Usually, in **obviousness** assessment, conflict claims (potential obvious claims) are identified, seen as the positive results (+). Consequently, non-conflict ones, are seen as negative results (-). Those claims identified by results of the method and results of authorised are called True Positive (TP); those identified as non-conflict

claims by the method but conflict by authorities are called False Negative (FN). TP and FN are used for precision calculation.

Table 4.1 Combined tests of sensitivity and specificity.

	Mapping results			Results of tests	
	+	-	Total		
Authorised results	+	True Positive (TP)	False Negative (FN)	Authorised positive (P= TP+ FN)	<i>Sensitivity</i> = TP/P
	-	False Positive (FP)	True Negative (TN)	Authorised negative (N= FP+ TN)	<i>Specificity</i> = TN/N

Combined tests of sensitivity and specificity (Fawcett, 2006) are implemented to test performances of the criteria sets. Sensitivity measures the proportion of legal judgments of conflict claims that are correctly identified by TRIZ-Led Patent Mapping in this paper while specificity measures the proportion of legal judgments of non-conflict claims that are correctly identified by the method (Altman and Bland, 1994):

- (1) Sensitivity is equal to common conflict claims over total conflict claims in the legal judgement; and
- (2) Specificity is equal to common no-conflict claims over total no-conflict claims in the legal judgement.

4.4.2 Result Comparison

In the aircraft seat case, two legal judgments are included here: the search report for patent application from the EPO (Ferry and Well, 2002) and the court judgments of patent invalidity lawsuits from the UK courts, see *Virgin v Zodiac* [2009] EWCA Civ 1062 and *Virgin v Zodiac*, [2013] UKSC 46. The result comparison and combined tests are shown in Table 4.2. The result comparison between legal judgments is further discussed in Chapter 6. As most current granted and published patents are attached by search reports and most court judgments are also open to the public, collecting these facts are not very difficult. Besides, the target patent A in this invalidity litigation was

later re-examined by the Technical Board of Appeal (TBA) and then amended as a valid patent.

Table 4.2 Result comparison of Case 1: using E_{12} .

	Mapping results using E_{12}		Legal judgments	
			EPO search report	UK court judgments
Conflict claims	A1; 6; 8-9; 11		A1; 3-11	A1; 9
Non-conflict claims	A2-5; 7; 10		A2	A2-8, 10-11

4.4.3 Combined Tests between Results

According to the result comparison above, the combined tests can be formed in [Table 4.3](#). Besides, in combined tests, correctly positioning results of methods (mapping results) and results in facts (legal judgments) is crucial to results of tests, i.e. values of sensitivity and specificity.

Table 4.3 Combined tests in Case 1: using E_{12} .

		Mapping results		Results of tests	
		Conflict A1; 6; 8-9; 11	No conflict A2-5; 7; 10	Total	
EPO search report	Conflict A1; 3-11	5 common claims (A1; 6; 8-9,11)	5 mis-identified claims (A3-5; 7; 10)	10	$Sensitivity = 5/10 = 50\%$
	No conflict A2	0 common claims	1 common claim	1	$Specificity = 1/1 = 100\%$
UK court judgments	Conflict A1; 9	2 common claims (A1; 9)	0 mis-identified claims	2	$Sensitivity = 2/2 = 100\%$
	No conflict A2-8, 10-11	3 common claims (A6; 8, 11)	6 common claims (A2-5; 7, 10)	9	$Specificity = 6/9 = 67\%$

4.4.4 Combined Tests between Criteria Sets

As the initial evaluation criteria set (E_{12}) had resulted in some missing and incorrectly identified claims in the mapping results, two new criteria sets E_{15} and E_{12b} (i.e. a new set of E_{12}) are developed here based on the initial criteria set E_{12} .

Using E_{12} the sensitivity and specificity were not high enough and it was observed that Force and Field were too general; therefore they split into two again. Also, as many claims mentioned Material and human-machine Interface then two new parameters were created, hence E_{15} (see [Table F.2](#)). However, whilst E_{15} did achieve sensitivity and specificity improvements, it was further observed that there were redundant parameters: Transformation, Interface and Force. In other words, the previous changes to Interface and Force also did not affect sensitivity and specificity as was expected. In order to let names of parameters cater for descriptions in claims, some parameters were precisely linked to design principles ([Zelanshi and Fisher, 1996](#)): Stable became Balance; Speed and Time became Cycle and Repeated. Finally, one parameter was separated: Moving became Rotating and Translating. Hence parameter set E_{12b} was created. Details of the criteria are displayed in [Table F.2](#). The combined tests in [Table 4.3](#) were repeated, which are shown in [Table 4.4,5](#).

Table 4.4 Combined tests in Case 1: using E_{15} .

		Mapping results using E_{15}			Results of tests
		Conflict A1; 3; 5; 6; 8; 9; 10	No conflict A2; 4; 7; 11	Total	
EPO search report	Conflict A1; 3-11	TP=7	FN= 3	10	<i>Sensitivity = 100%</i>
	No conflict A2	FP= 0	TN=1	1	<i>Specificity = 25%</i>
UK court judgments	Conflict A1; 9	TP= 2	FN= 5	7	<i>Sensitivity = 100%</i>
	No conflict A2-8, 10-11	FP= 0	TN= 4	4	<i>Specificity = 44%</i>

Table 4.5 Combined tests in Case 1: using E_{12b} .

		Mapping results using E_{12b}			Results of tests	
		Conflict	No conflict	Total		
		A1; 4-6; 8	A2; 3; 7; 9; 10			
EPO search report	Conflict A1; 3-11	TP= 5	FN= 5	10	<i>Sensitivity = 100%</i>	
	No conflict A2	FP= 0	TN= 1	1	<i>Specificity = 17%</i>	
UK court judgments	Conflict A1; 9	TP= 1	FN= 4	5	<i>Sensitivity = 50%</i>	
	No conflict A2-8, 10-11	FP= 1	TN= 5	6	<i>Specificity = 56%</i>	

4.5 Precision Calculation

The precision and accuracy of the new method, using the definitions from informatics (Powers, 2007) rather than engineering are calculated according to (1) and (2) below. Precision is used to represent the degree of **obviousness**, in other words the degree of confidence in using any particular method (Powers, 2007); by means of a percentage, and this is the main selection index. Accuracy represents the percentage of conflicts for which precision has been calculated and is used here as an additional selection index for when precision values are the same.

$$(1) \text{ Precision} = 100(\text{TP} / (\text{TP} + \text{FP})); \text{ and}$$

$$(2) \text{ Accuracy} = 100((\text{TP} + \text{TN}) / (\text{P} + \text{N})).$$

TP, FP, P and N are defined in Table 4.1.

The precision and accuracy in using different evaluation criteria sets when comparing legal judgments in this case are shown in Table 4.6.

Table 4.6 Precision and accuracy calculation based on the group evaluation results.

Evaluation criteria sets	Compared with EPO search report		Compared with UK court judgments	
	Precision	Accuracy	Precision	Accuracy
E_{12}	100%	55%	40%	55%
E_{15}	100%	73%	100%	55%
E_{12b}	100%	55%	50%	55%

4.6 Summary of Chapter 4

In summary, the main repeatability error of the new method has two components, which are found by:

- (1) Reliability test: consistency of evaluation results between evaluators is solved by consensus in a focus group; consistency of evaluation results due to using different criteria is tested by the Cronbach's method, and
- (2) Validity test: precision of sets of evaluation criteria between different patent cases is tested by the combined tests (sensitivity and specificity). All the validation results are listed in [Table 4.7](#), which shows the cross-comparison (sensitivity, specificity, precision, and accuracy) between criteria sets and legal judgments in one case. To reduce this aspect of repeatability error, this method adopts precision and accuracy as feedback to iteratively improve the criteria.

Table 4.7 Cross-comparison between criteria sets and legal judgments.

Evaluation criteria sets	Compared with EPO search report				Compared with UK court judgments			
	Sensitivity	Specificity	Precision	Accuracy	Sensitivity	Specificity	Precision	Accuracy
E_{12}	50%	100%	100%	55%	100%	67%	40%	55%
E_{15}	100%	25%	100%	73%	100%	44%	100%	55%
E_{12b}	100%	17%	100%	55%	50%	56%	50%	55%

The cross-comparison above reveals that it is difficult to simultaneously achieve a high sensitivity and a high specificity; and also sometimes they will be biased towards one or the other for different legal judgments. To correctly identify conflict claims, the criteria set with the consistently higher sensitivity (E_{15}) is selected; conversely, to correctly identify the non-conflict claims, the set with consistently higher specificity (E_{12}) is selected; if high precision is required then E_{15} is selected.

This cross-comparison has been used for the other case studies that follow. This contributes to a more scientific method compared with the current legal approach.

Chapter 4 explained the validation of the method based upon one case study and to avoid such a “cold start problem”, i.e. the lack of the initial input data, the more case studies that are accumulated, the higher the confidence in the results. The next chapter demonstrates the results of three more case studies from the field of mechanical engineering.

Chapter 5 Applications

5.1 Introduction to Chapter 5

Chapter 5 contains three case studies which demonstrate the applications of TRIZ-Led Patent Mapping. These applications firstly use the criteria set of E_{12} for gaining mapping results because it leads to high precision and contains a lower number of elements which saves evaluation time; and secondly, for cross-comparison, adopts the other two evaluation criteria sets (E_{15} and E_{12b}) to achieve optimised criteria by statistical high precision in each case study. The authorised results include UKIPO search report in Case 2 and Case 3; patent attorney's claim chart in Case 4; and the amended patent in Case 1.

5.2 Case 2: Nasal Prong Interface

5.2.1 Overview of Case 2

The target patent is A, GB11135XX.2 (to be prudential, some application numbers, which are vital to the patent holders, are partially shown in the paper); the comparable patents are B, WO2008/10086XXA2; C, US2003/0941XXA1; and D, US41564XXA. This real case was provided by one of the author's industrial partners presenting its patent application and search report. The main dispute was about the design of the foam plug part in the nostril interface, which was queried as lack of novelty and inventiveness by the examiner (GB11135XX.2). The drawing in the target patent is displayed as following (Figure 5.1):

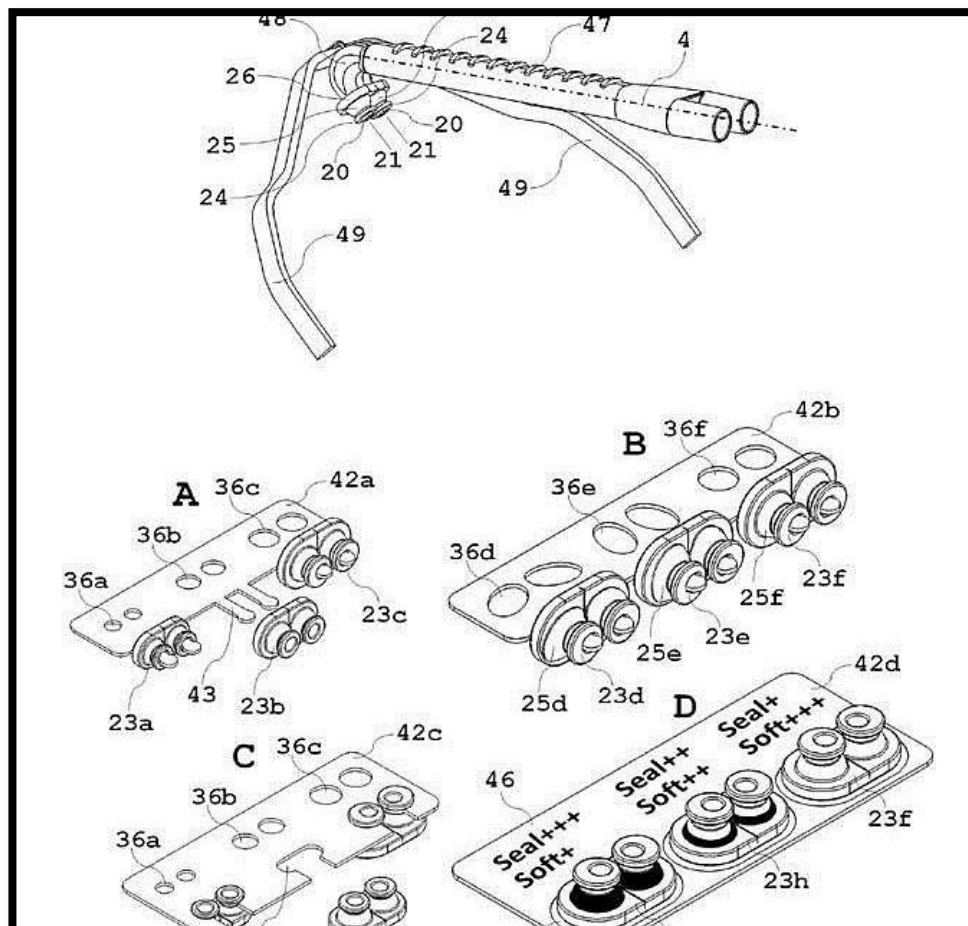

Figure 5.1 Invention of target patent (GB11135XX.2) in Case 2: nasal prong interface.

5.2.2 Using E_{12} in Case 2

The results are displayed in Figure 5.2,3 and Table 5.1.

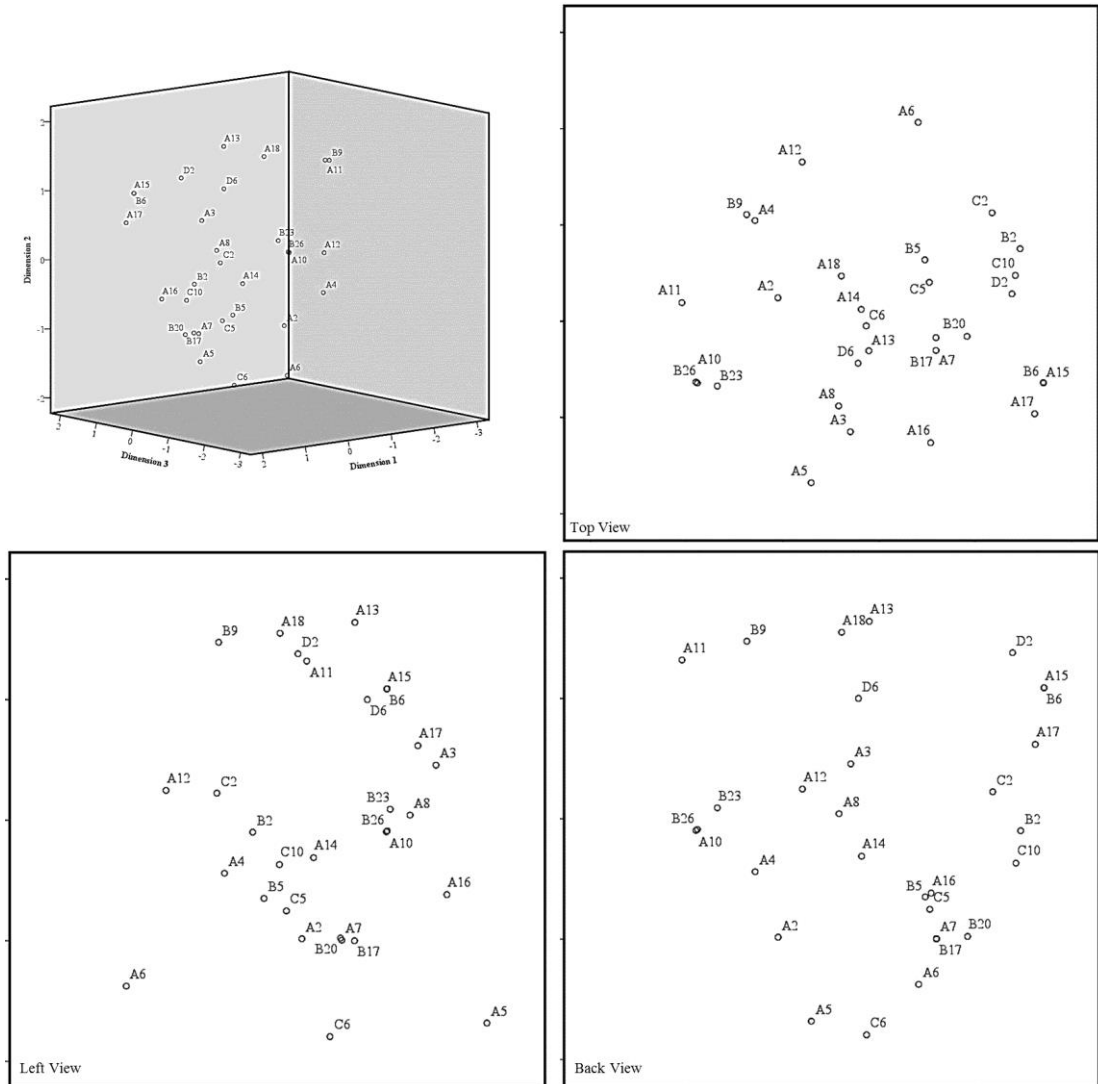

Figure 5.2 Mapping results in Case 2: using E_{12} .
 (Stress=0.16 and RSQ=0.84, from SPSS; an enlarged map is shown below)

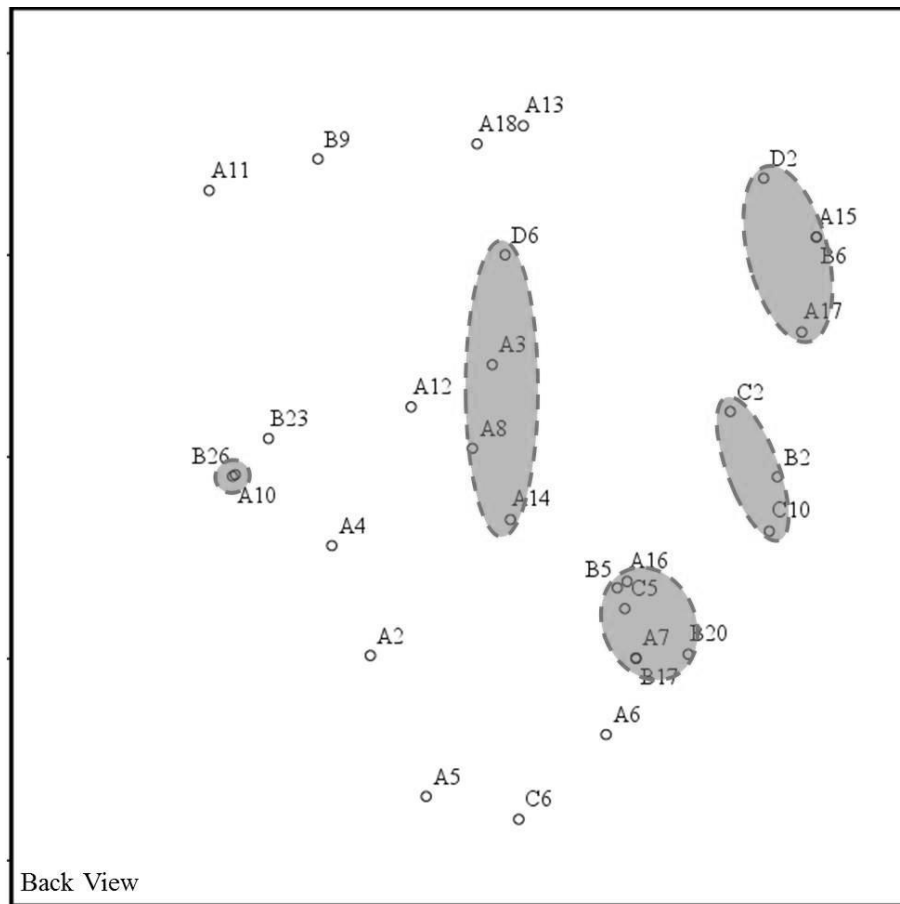

Figure 5.3 Part of the mapping results in Case 2: using E_{12} .

Table 5.1 Combined tests in Case 2: using E_{12} .

		Mapping results			Sensitivity and specificity	
		Conflict	No conflict	Total		
		A1; 3; 7; 8; 10; 14-18	A2; 4-6; 9; 11-13			
UKIPO search report	Conflict	TP= 6	FN= 4	10	<i>Sensitivity = 60%</i>	
	A1-6; 8; 10; 15; 18					
	No conflict	FP= 4	TN= 4	8	<i>Specificity = 50%</i>	
	A7; 9; 11-14; 16; 17					

5.2.3 Using E_{15} in Case 2

The results are shown in Figure 5.4,5 and Table 5.2.

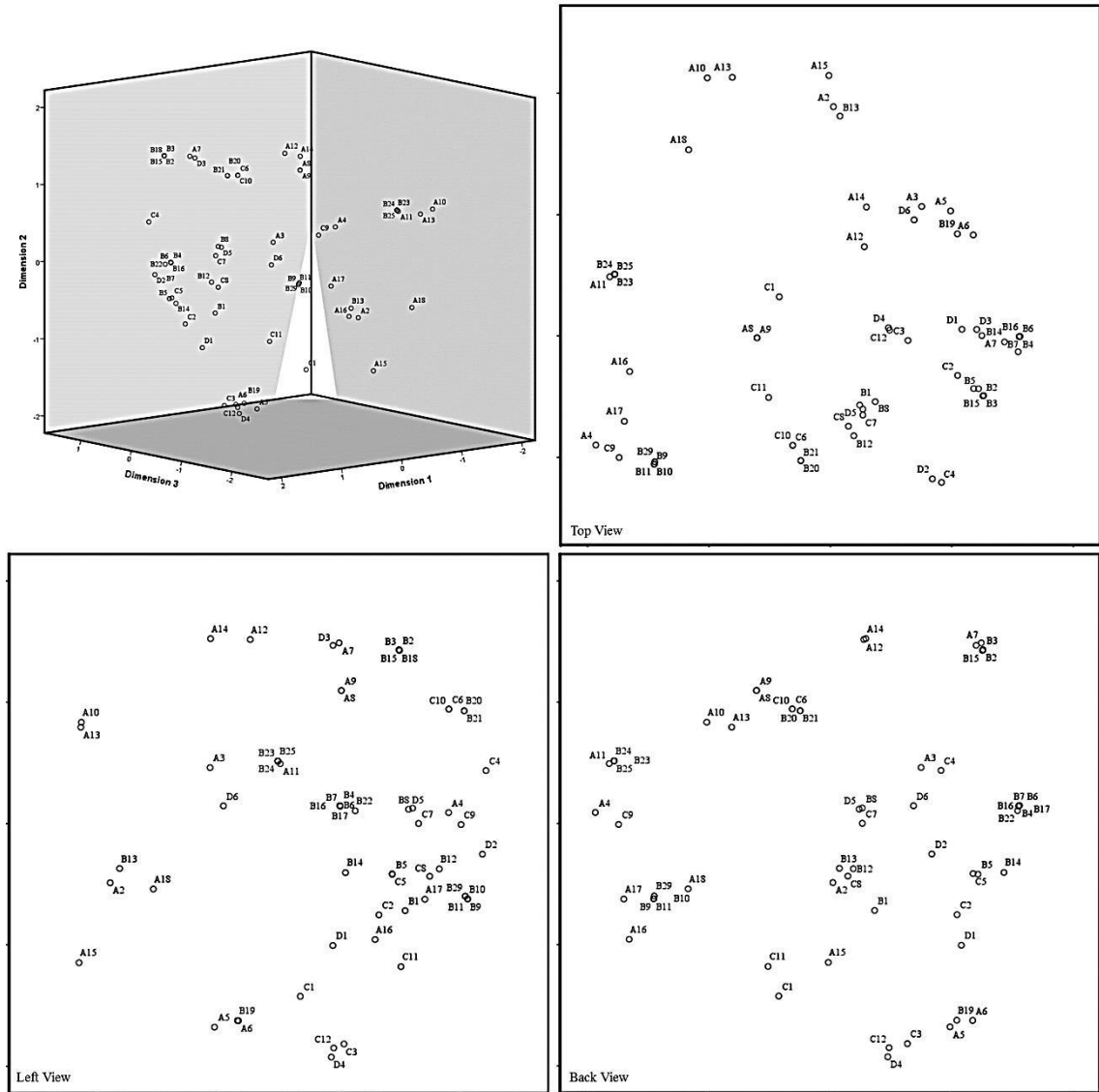

Figure 5.4 Mapping results in Case 2: using E_{15} .
(Stress=0.17 and RSQ=0.82, from SPSS; an enlarged map is shown below)

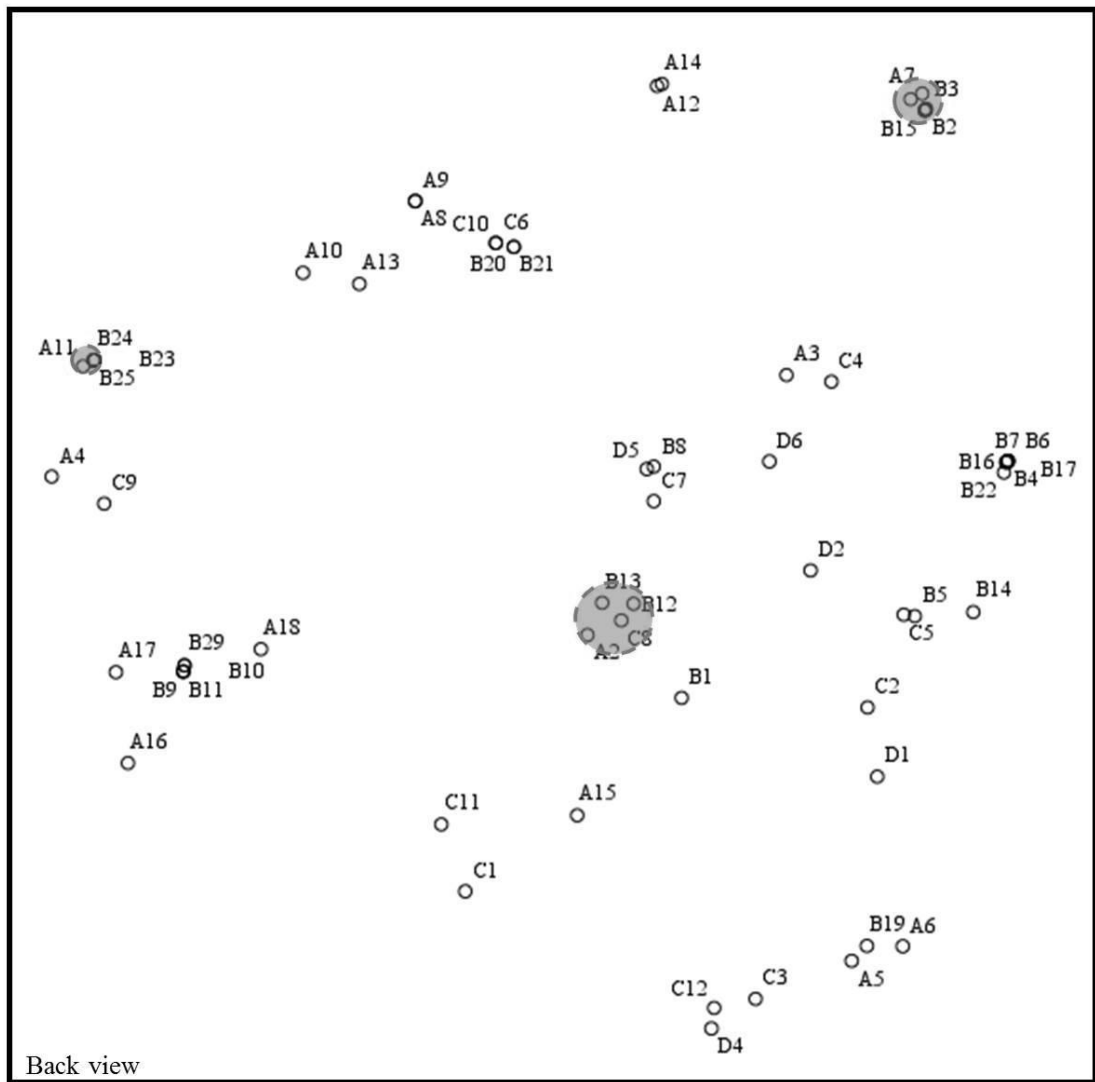

Figure 5.5 Part of the mapping results in Case 2: using E_{15} .

Table 5.2 Combined tests in Case 2: using E_{15} .

		Mapping results			Sensitivity and specificity	
		Conflict	No conflict	Total		
		A1-3; 7; 11	A4-6; 8-10; 12-18			
UKIPO search report	Conflict	TP= 3	FN= 7	10	<i>Sensitivity = 30%</i>	
	A1-6; 8; 10; 15; 18					
	No conflict	FP= 2	TN= 6	8	<i>Specificity = 75%</i>	
	A7; 9; 11-14; 16; 17					

5.2.4 Using E_{12b} in Case 2

The results are shown in Figure 5.6,7 and Table 5.3.

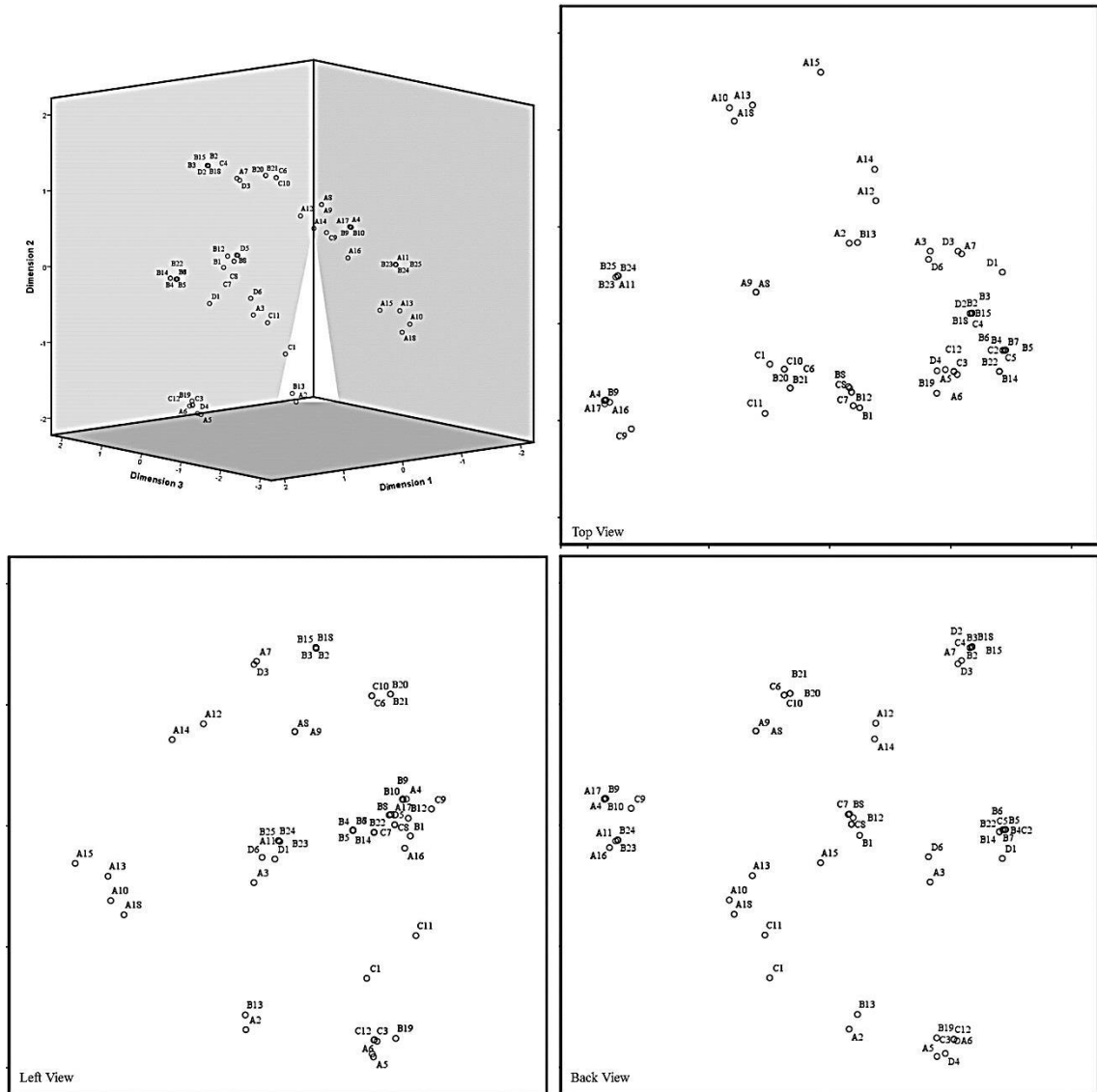

Figure 5.6 Mapping results in Case 2: using E_{12b} .
 (Stress=0.15 and RSQ=0.89, from SPSS; an enlarged map is shown below)

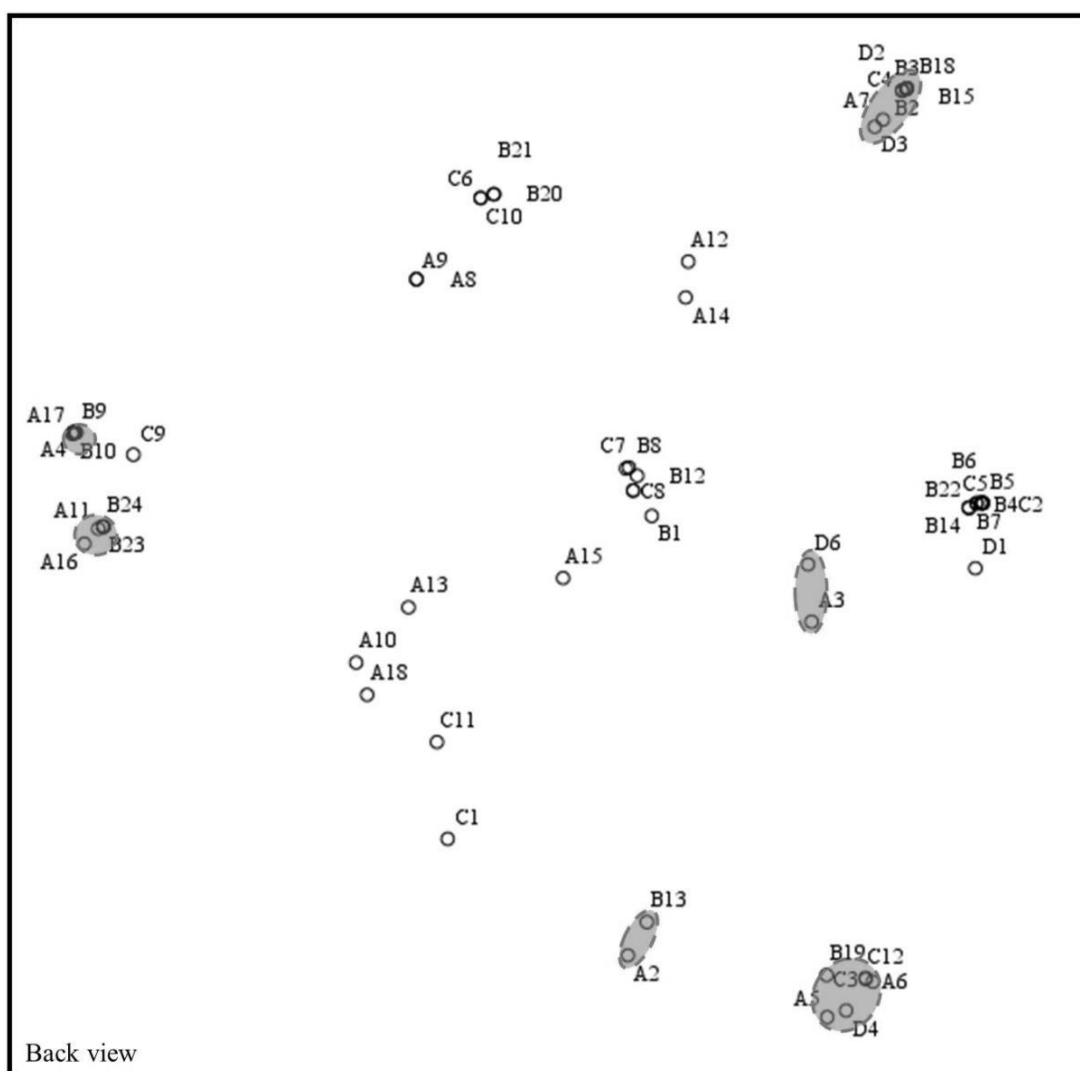

Figure 5.7 Part of the mapping results in Case 2: using E_{12b} .

Table 5.3 Combined tests in Case 2: using E_{12b} .

		Mapping results			Sensitivity and specificity	
		Conflict	No conflict	Total		
		A1-7; 11; 17	A8-10; 12-16; 18			
UKIPO search report	Conflict	TP= 6	FN= 4	10	<i>Sensitivity = 60 %</i>	
	A1-6; 8; 10; 15; 18					
	No conflict	FP= 3	TN= 5	8	<i>Specificity = 50%</i>	
	A7; 9; 11-14; 16; 17					

5.2.5 Improved E_k for Case 2

Based on the results above, the values of precision and accuracy are listed in [Table 5.4](#). The E_k that achieves the highest precision is considered as the optimised criteria set for Case 2, which is E_{12b} . The less preferable one is E_{12} , which has a little better higher accuracy value than that of E_{15} .

Table 5.4 Precision and accuracy calculation for Case 2.

Evaluation criteria sets	Compared with UKIPO search report	
	Precision	Accuracy
E_{12}	60%	56%
E_{15}	60%	50%
E_{12b}	67%	61%

5.3 Case 3: Noise Reduction Device

5.3.1 Overview of Case 3

The target patent is GB13131XX.5 (application number), marked as A; the comparable patents are US2006/0428XXA1, as B; WO98/194XXA1, as C. This real case was provided by one of the author's industrial partners in patent application. The examiner implied potential similarity of the structure of the device, especially the 3D appearance and the curved resonator tubes. However, no certain claim conflict was identified (GB13131XX.5). The drawing in the target patent is displayed as following (Figure 5.8):

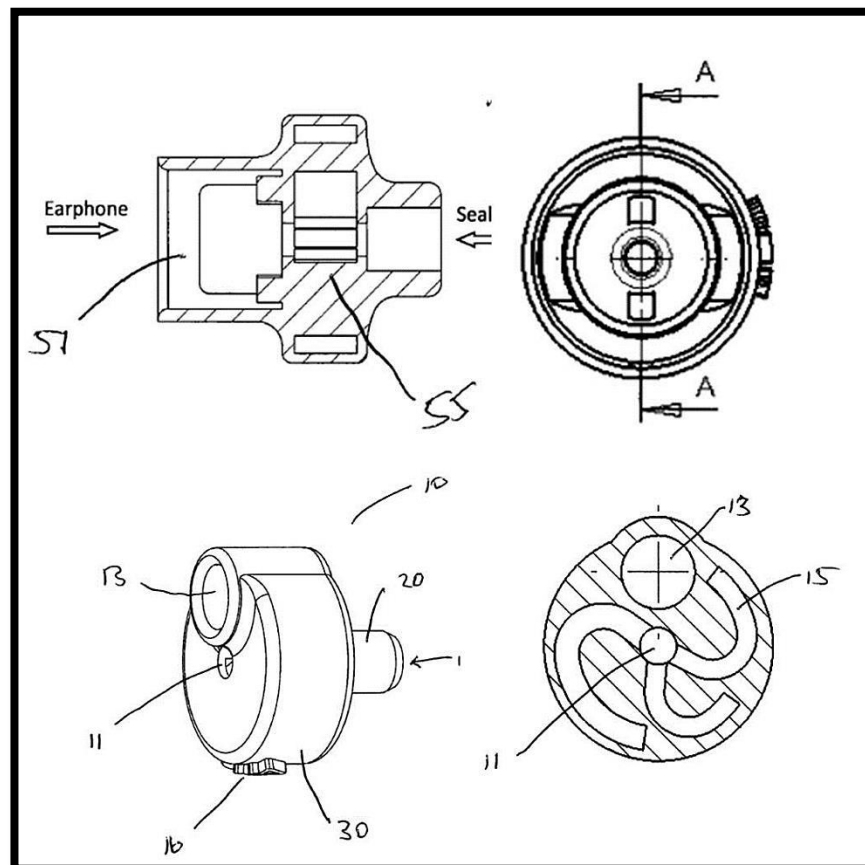
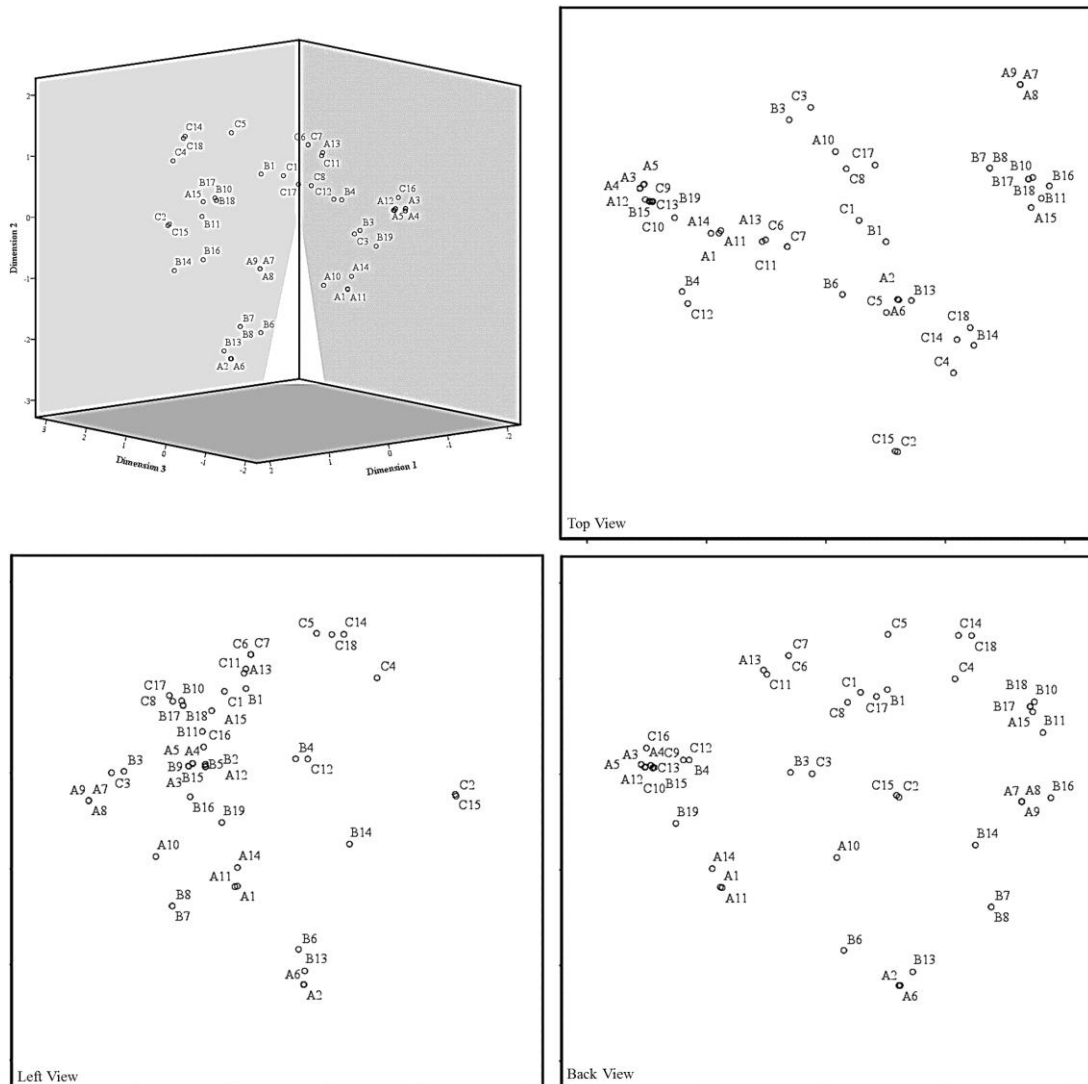

Figure 5.8 Invention of target patent (GB13131XX.5) in Case 3: noise reduction device.

5.3.2 Using E_{12} in Case 3

The results are displayed in Figure 5.9,10 and Table 5.5.

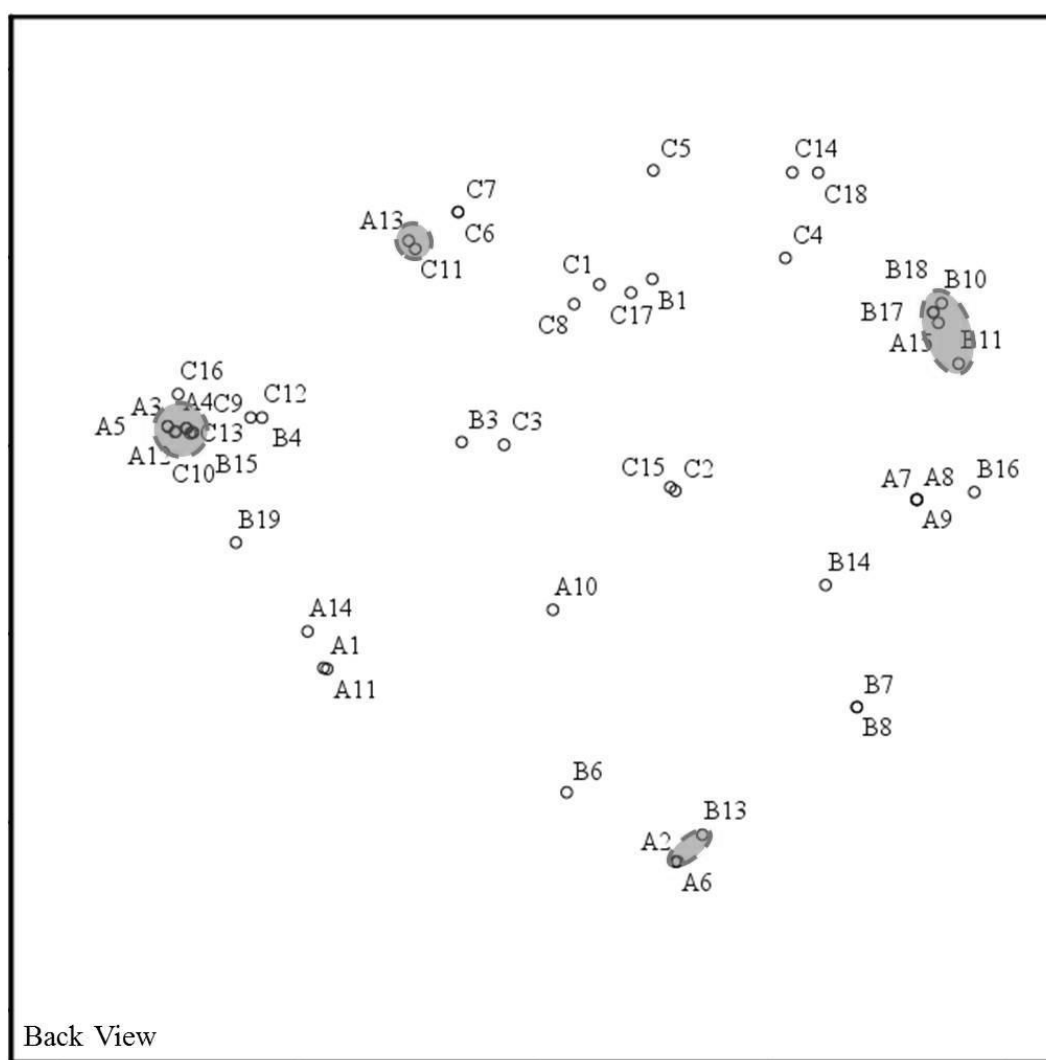

**Figure 5.9 Mapping results in Case 3: using E_{12} .
 (Stress=0.18 and RSQ=0.83, from SPSS; an enlarged map is shown below)**

Figure 5.10 Part of the mapping results in Case 3: using E_{12} .Table 5.5 Combined tests in Case 3: using E_{12} .

		Mapping results			Sensitivity and specificity	
		Conflict	No conflict	Total		
		A1-6; 12; 13; 15	A7-11; 14			
UKIPO search report	Conflict 0	TP= 0	FN= 0	0	<i>Sensitivity</i> = 0%	
	No conflict A1-15	FP= 9	TN= 6	15	<i>Specificity</i> = 100%	

5.3.3 Using E_{15} in Case 3

The results are shown in Figure 5.11,12 and Table 5.6.

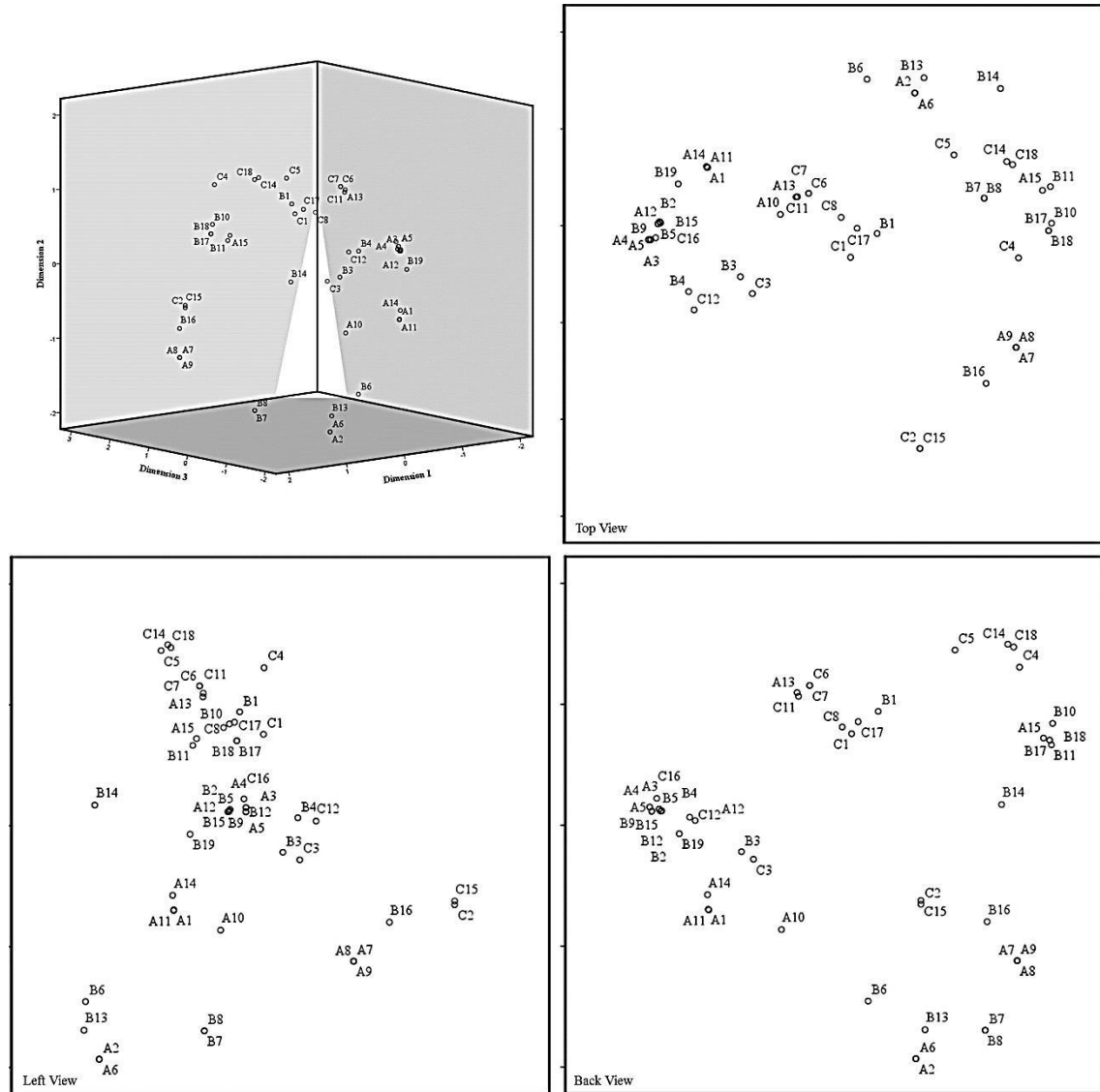

**Figure 5.11 Mapping results in Case 3: using E_{15} .
(Stress=0.14 and RSQ=0.90, from SPSS; an enlarged map is shown below)**

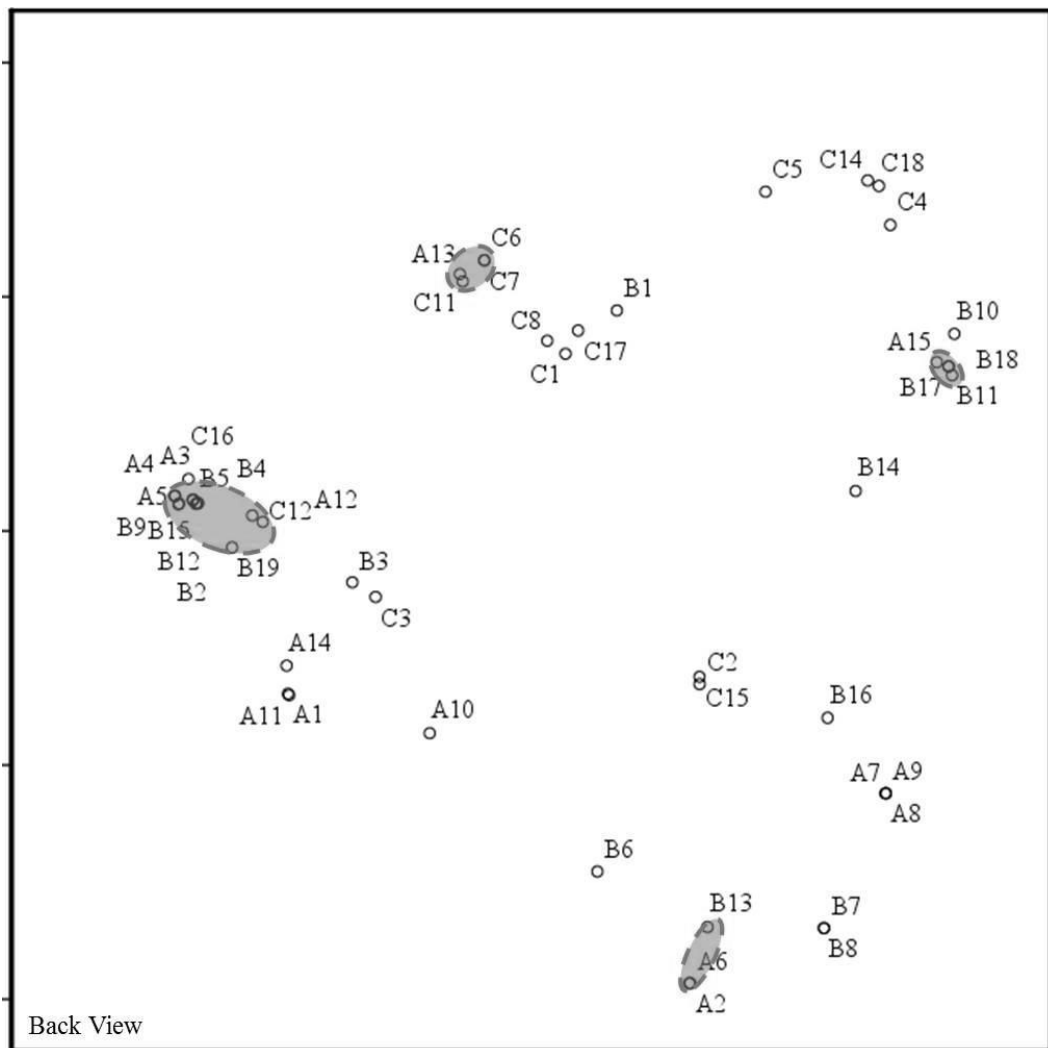

Figure 5.12 Part of the mapping results in Case 3: using E_{15} .

Table 5.6 Combined tests in Case 3: using E_{15} .

		Mapping results			Sensitivity and specificity	
		Conflict A1-6; 12-15	No conflict A7-11	Total		
UKIPO search report	Conflict 0	TP= 0	FN= 0	0	<i>Sensitivity = 0%</i>	
	No conflict A1-15	FP= 10	TN= 5	8	<i>Specificity = 63%</i>	

5.3.4 Using E_{12b} in Case 3

The results are shown in Figure 5.13,14 and Table 5.7.

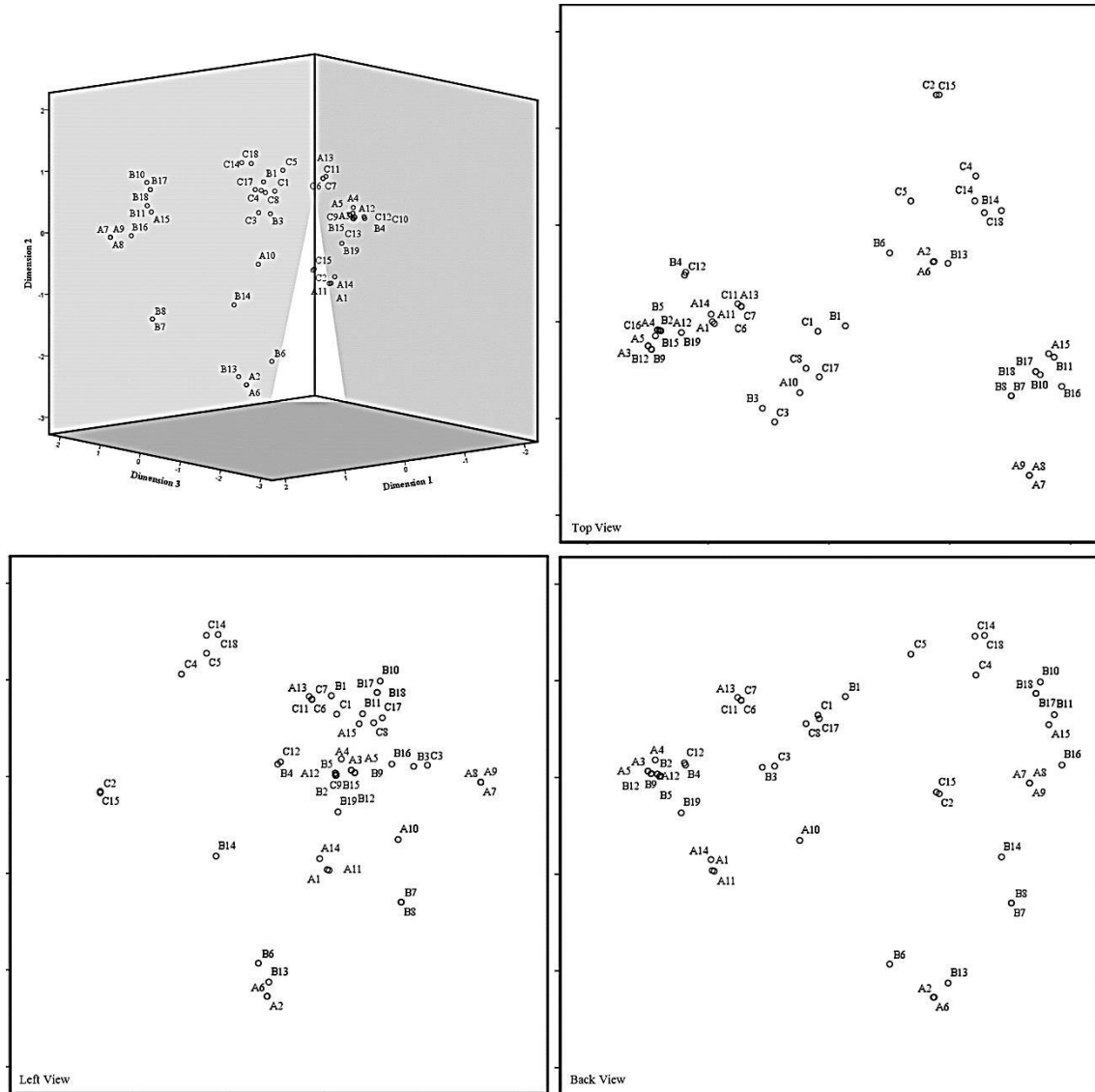

**Figure 5.13 Mapping results in Case 3: using E_{12b} .
(Stress=0.16 and RSQ=0.88, from SPSS; an enlarged map is shown below)**

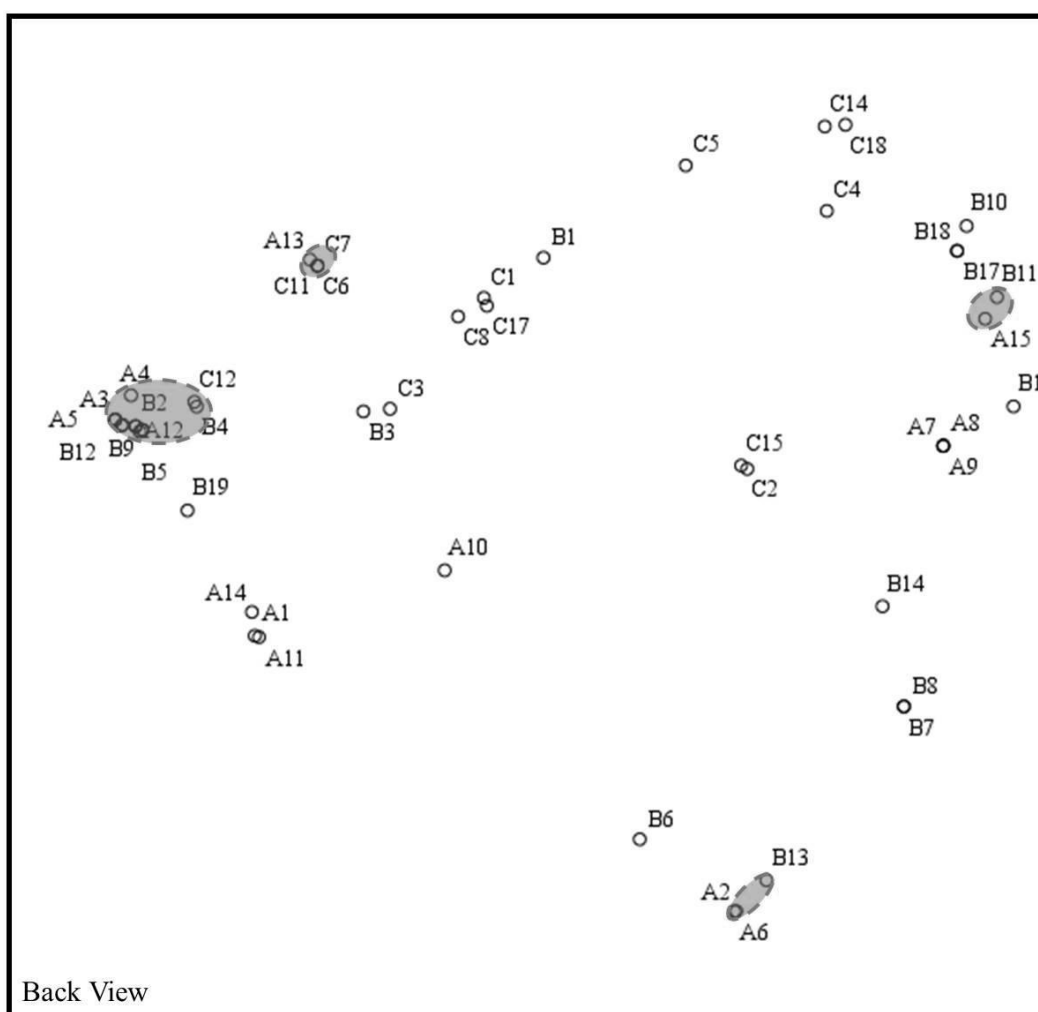

Figure 5.14 Part of the mapping results in Case 3: using E_{12b} .

Table 5.7 Combined tests in Case 3: using E_{12b} .

		Mapping results			Sensitivity and specificity	
		Conflict A1-6; 12-15	No conflict A7-11	Total		
UKIPO search report	Conflict 0	TP= 0	FN= 0	0	<i>Sensitivity = 0%</i>	
	No conflict A1-15	FP= 10	TN= 5	15	<i>Specificity = 63%</i>	

5.3.5 Improved E_k for Case 3

Based on the results above, the values of precision and accuracy are listed in [Table 5.8](#). As all precision values is 0, the preferable E_k is selected by accuracy, which is E_{12} for Case 3.

Table 5.8 Precision and accuracy calculation for Case 3.

Evaluation criteria sets	Compared with UKIPO search report	
	Precision	Accuracy
E_{12}	0%	40%
E_{15}	0%	33%
E_{12b}	0%	33%

5.4 Case 4: Metal Enclosure

5.4.1 Overview of Case 4

This real case was provided by one of the author's long-term partners from industry. In this case, the target patent is US51879XXA, marked as A; the comparable patents are EP23599XXA1, as B; US2008/02165XXA1, as D. The partner UK patent attorney provides the claim chart (Figure 5.15). Because of the Non-Disclosure Agreement signed with the partner, only part of the contents of the chart is shown here which is clearly enough to demonstrate typical claim chart. The dispute was around the **obviousness** of the support/base of the machine tool which fixes the enclosure.

Claim 1 - (independent) An apparatus for XXXXXXXX	✓ Abstract, description para. 0001	✓ Abstract, Background line 16, whole contents
Having first & second XXX, at least one end being open	✓ Description para. 0002	✓ Column 2, lines 15 & 16
Claim 2 – (dep. on claim 1) Apparatus in which at least one XXXX member includes an open end member joined to XXXX by a XXXX at the 1 st end of the XXXX, and	? talks about interconnecting XXXX and “XXXX means” etc., but sounds like XXXX	✓ Column 2, lines 15 & 16
Claim 3 – (dep. on claim 1) Apparatus in which at least one end member includes a XXXX joined to body member by a XXXX at the 2 nd end of the XXXX, and...	✓ Para. 0022, iii	✓ Column 3, lines 50 – 55

Figure 5.15 Part of the claim chart provided by the UK patent attorney.

According to approximate comparison of time costs between using the new method (around two hours per person on average for completing the evaluation sheet involving the three patents) and patent attorney's claim chart (at least four hours for the same work), the new method spent only half of the time that the claim chart required.

5.4.2 Using E_{12} in Case 4

The results are displayed in Figure 5.16,17 and Table 5.9.

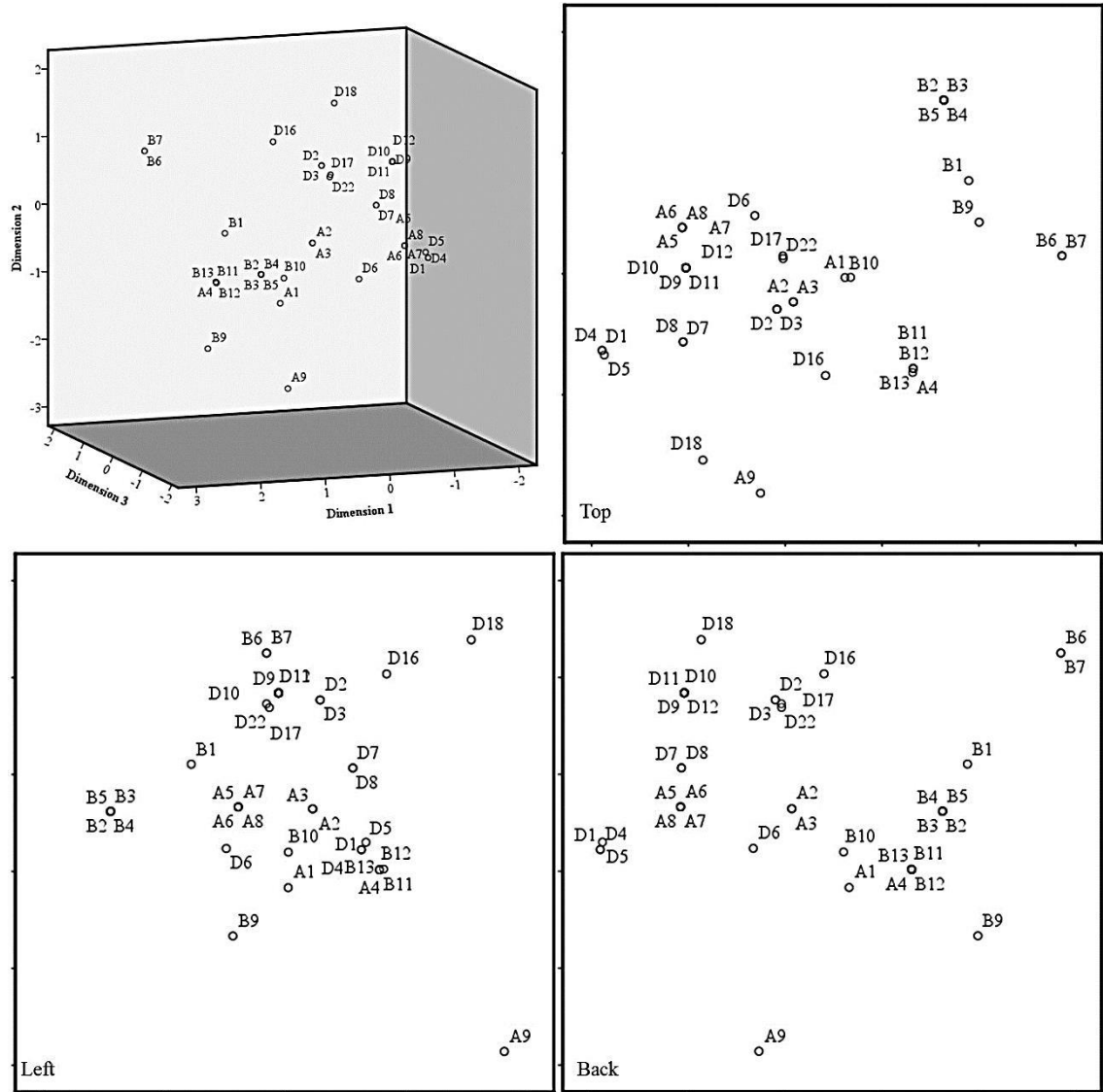

Figure 5.16 Mapping results in Case 4: using E_{12} .
 (Stress=0.18 and RSQ=0.81, from SPSS; an enlarged map is shown below)

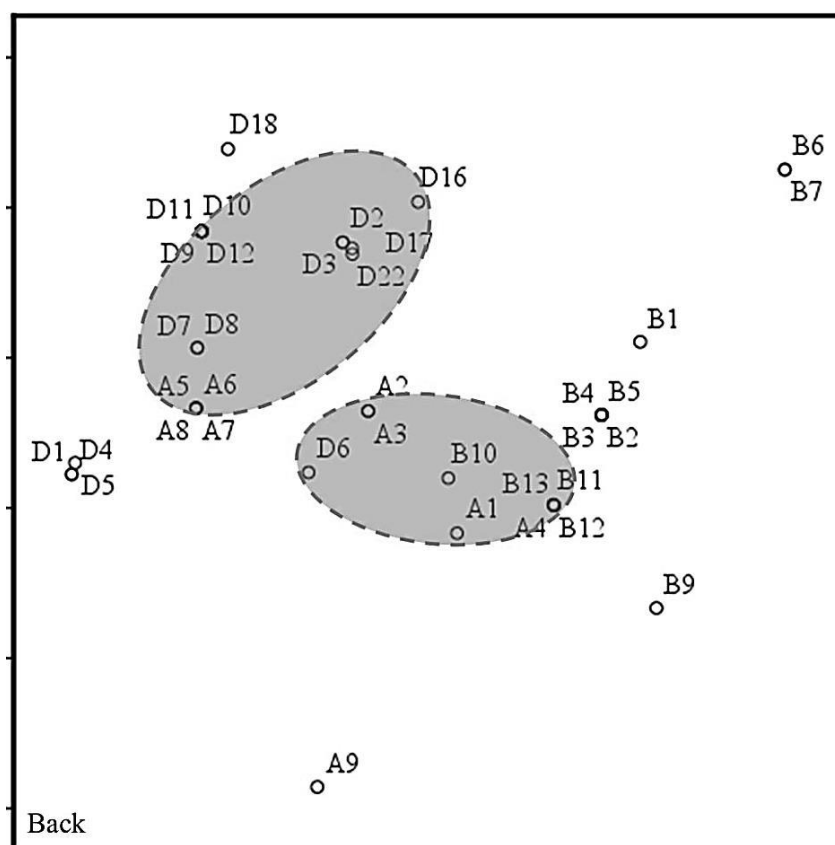

Figure 5.17 Part of the mapping results in Case 4: using E_{12} .

Table 5.9 Combined tests in Case 4: using E_{12} .

		Mapping results			Sensitivity and specificity	
		Conflict A1-8	No conflict A9	Total		
Patent attorney claim chart	Conflict A1-3	TP= 3	FN= 0	3	<i>Sensitivity = 100%</i>	
	No conflict A4-9	FP= 5	TN= 1	6	<i>Specificity = 17%</i>	

5.4.3 Using E_{15} in Case 4

The results are shown in [Figure 5.18,19](#) and [Table 5.10](#).

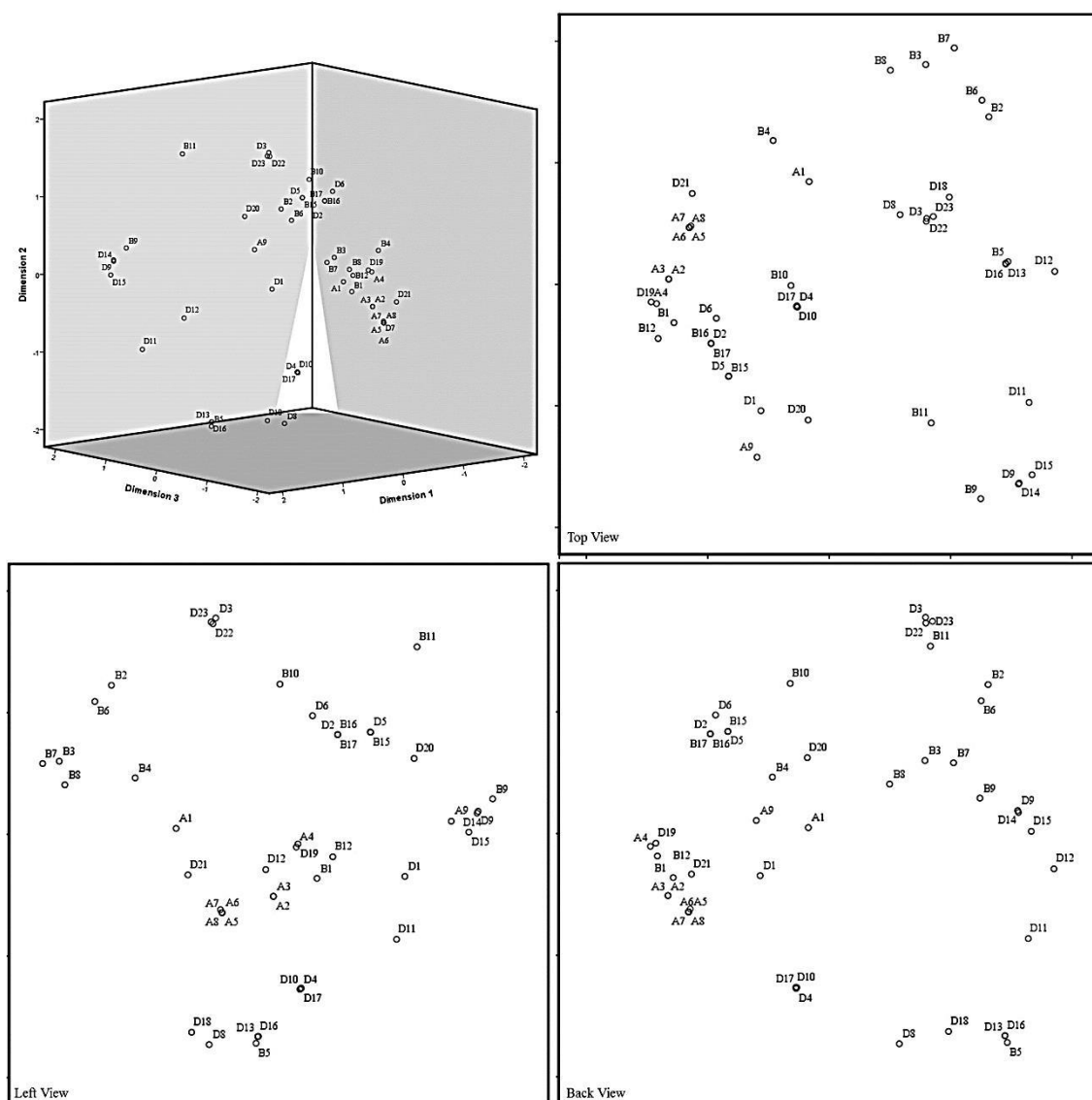

**Figure 5.18 Mapping results in Case 4: using E_{15} .
 (Stress=0.18 and RSQ=0.81, from SPSS; an enlarged map is shown below)**

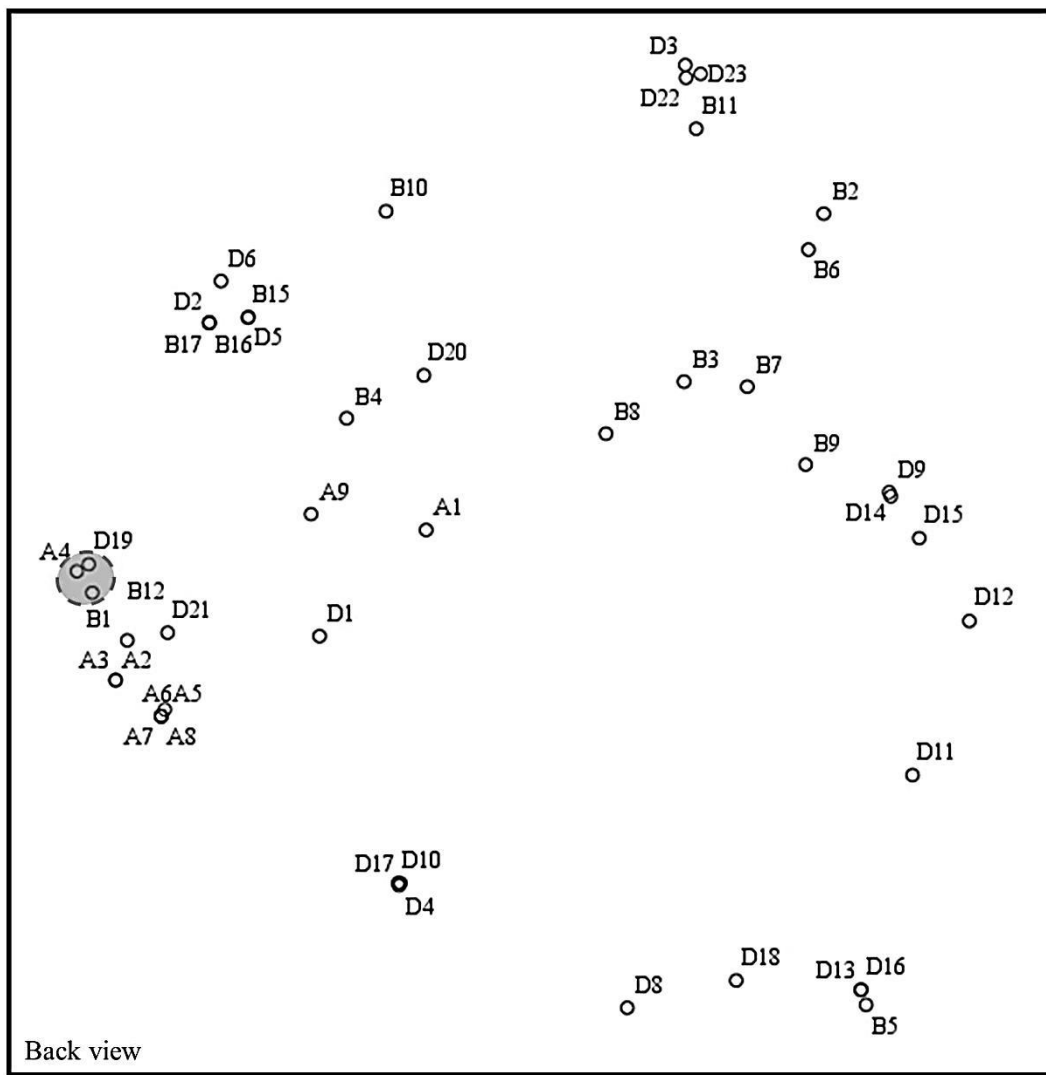

Figure 5.19 Part of the mapping results in Case 4: using E_{15} .

Table 5.10 Combined tests in Case 4: using E_{15} .

		Mapping results			Sensitivity and specificity
		Conflict	No conflict	Total	
		A1; 4	A2; 3; 5-9		
Patent attorney claim chart	Conflict A1-3	TP= 1	FN= 2	3	<i>Sensitivity = 33%</i>
	No conflict A4-9	FP= 1	TN= 5	6	<i>Specificity = 83%</i>

5.4.4 Using E_{12b} in Case 4

The results are shown in Figure 5.20,21 and Table 5.11.

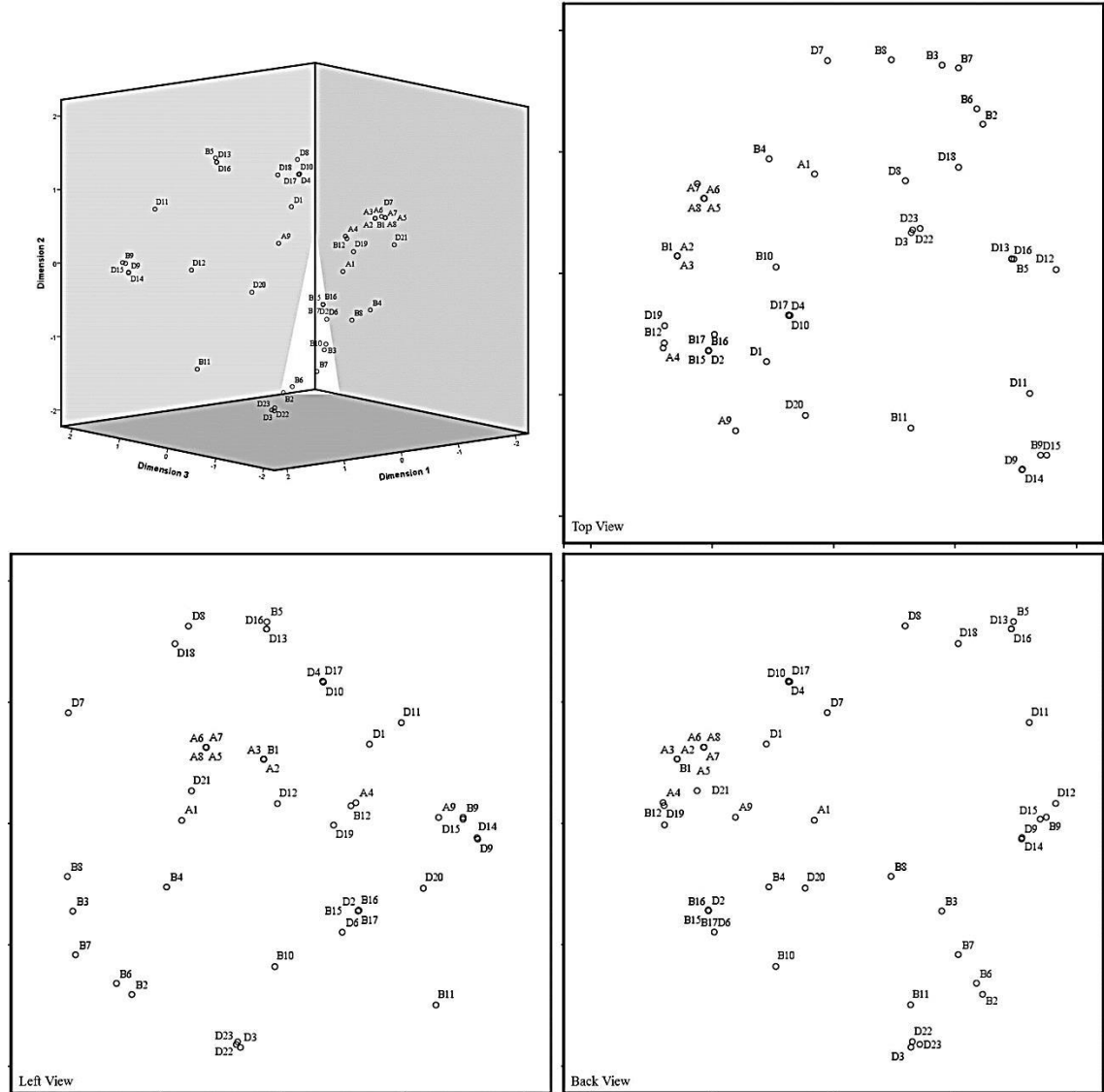

**Figure 5.20 Mapping results in Case 4: using E_{12b} .
(Stress=0.17 and RSQ=0.82, from SPSS; an enlarged map is shown below)**

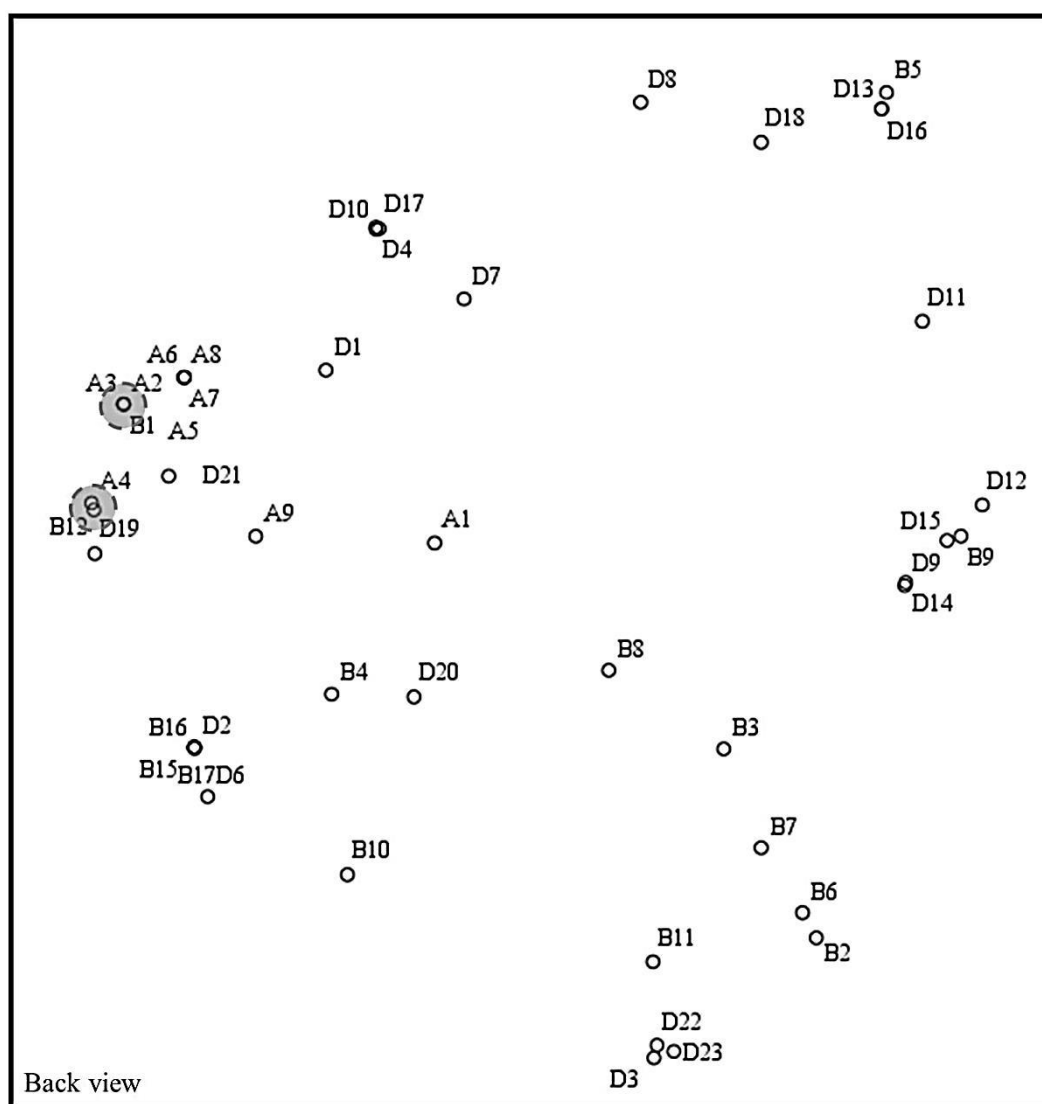

Figure 5.21 Part of the mapping results in Case 4: using E_{12b} .

Table 5.11 Combined tests in Case 4: using E_{12b} .

		Mapping results			Sensitivity and specificity	
		Conflict A1-4	No conflict A5-9	Total		
Patent attorney claim chart	Conflict A1-3	TP= 3	FN= 0	3	<i>Sensitivity = 100%</i>	
	No conflict A4-9	FP= 1	TN= 5	6	<i>Specificity = 83%</i>	

5.4.5 Improved E_k for Case 4

Based on the results above, the values of precision and accuracy are listed in [Table 5.12](#).

Table 5.12 Precision and accuracy calculation for Case 4.

Evaluation criteria sets	Compared with patent attorney's claim chart	
	Precision	Accuracy
E_{12}	38%	44%
E_{15}	50%	67%
E_{12b}	75%	89%

5.5 Case 1 Amended

5.5.1 Overview of Case 1 Amended

In Case 1, the target patent A has been amended after the invalidity litigation, remarked as “aa”. Case 1 amended shows the mapping of patent aa with patent B and patent C.

5.5.2 Using E_{12} in Case 1 Amended

The results are demonstrated in [Figure 5.22,23](#) and [Table 5.13](#).

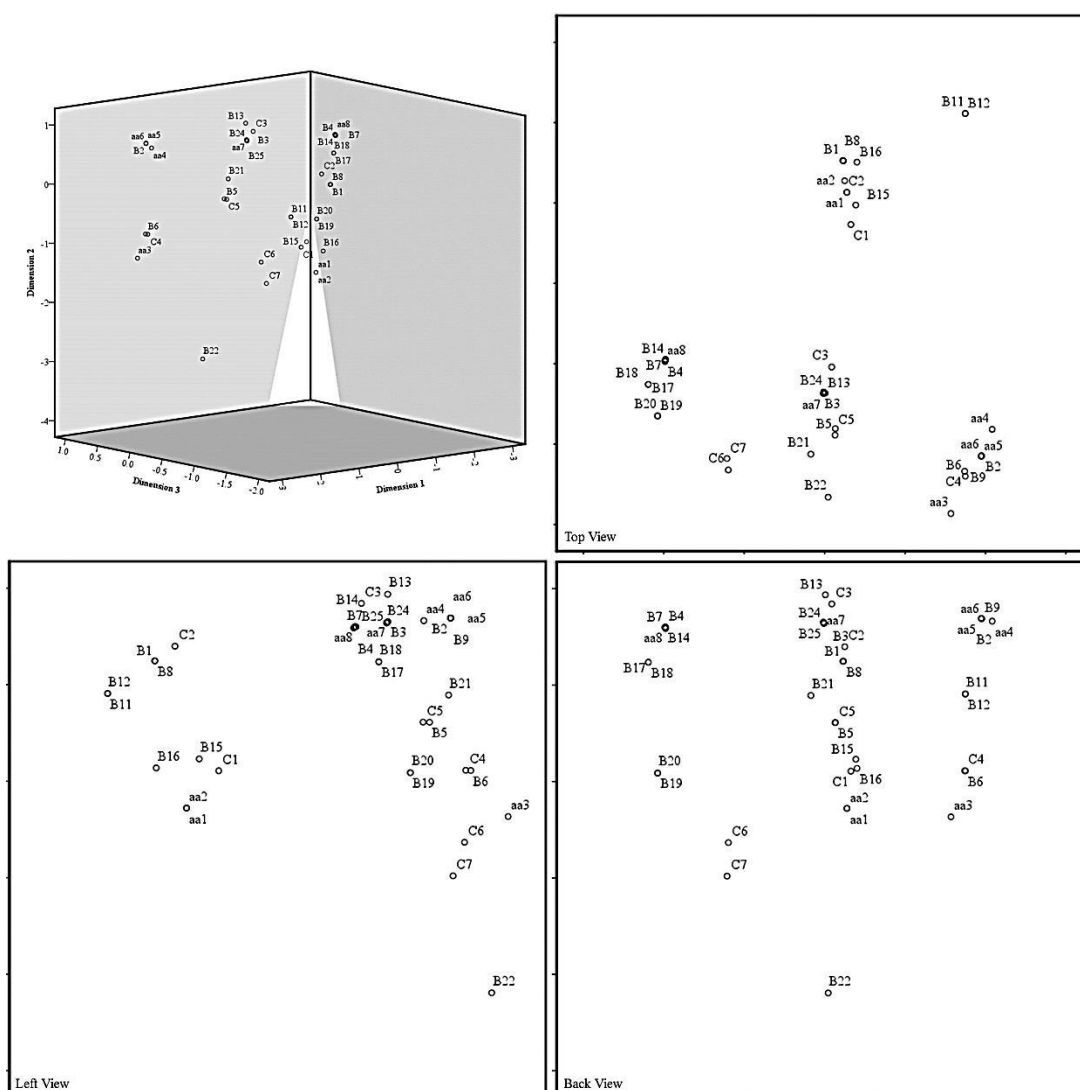

Figure 5.22 Mapping results of Case 1 amended: using E_{12} .
(Stress=0.17 and RSQ=0.82, from SPSS; an enlarged map is shown below)

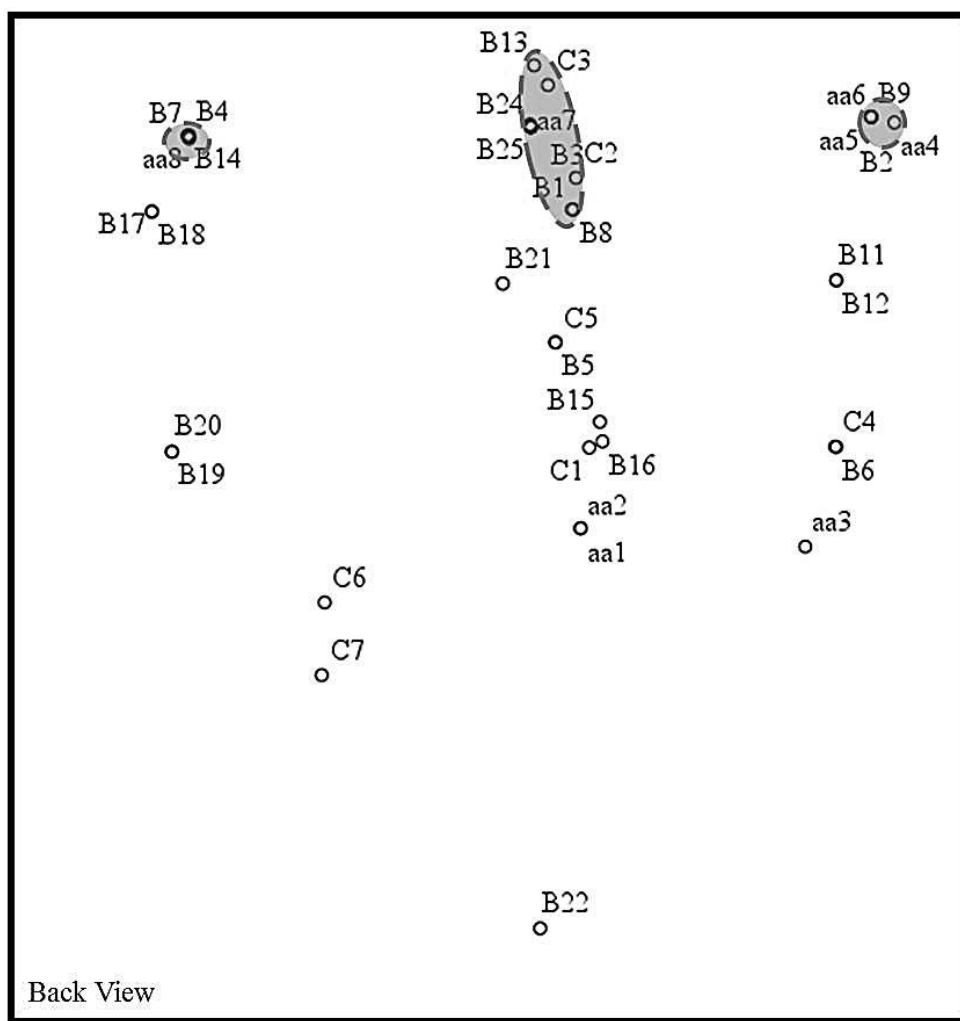

Figure 5.23 Part of the mapping results of Case 1 amended: using E_{12} .

Table 5.13 Combined tests of Case 1 amended: using E_{12} .

		Mapping results			Sensitivity and specificity	
		Conflict aa1; 2; 4-8	No conflict aa3	Total		
Patent attorney claim chart	Conflict 0	TP= 0	FN= 0	0	<i>Sensitivity</i> = 0%	
	No conflict aa1-8	FP= 7	TN= 1	8	<i>Specificity</i> = 13%	

5.5.3 Using E_{15} in Case 1 Amended

The results are demonstrated in Figure 5.24,25 and Table 5.14.

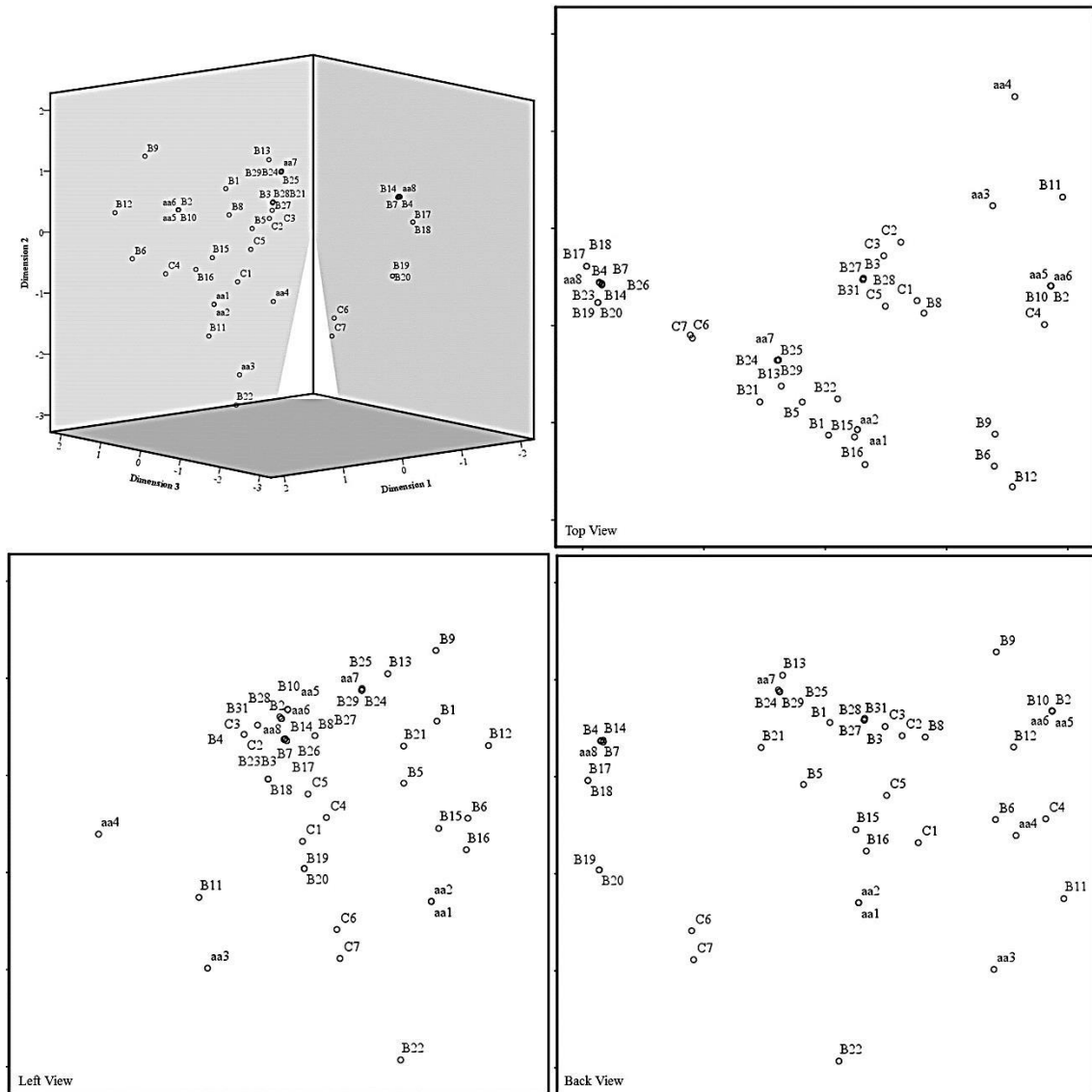

**Figure 5.24 Mapping results of Case 1 amended: using E_{15} .
(Stress=0.15 and RSQ=0.89, from SPSS; an enlarged map is shown below)**

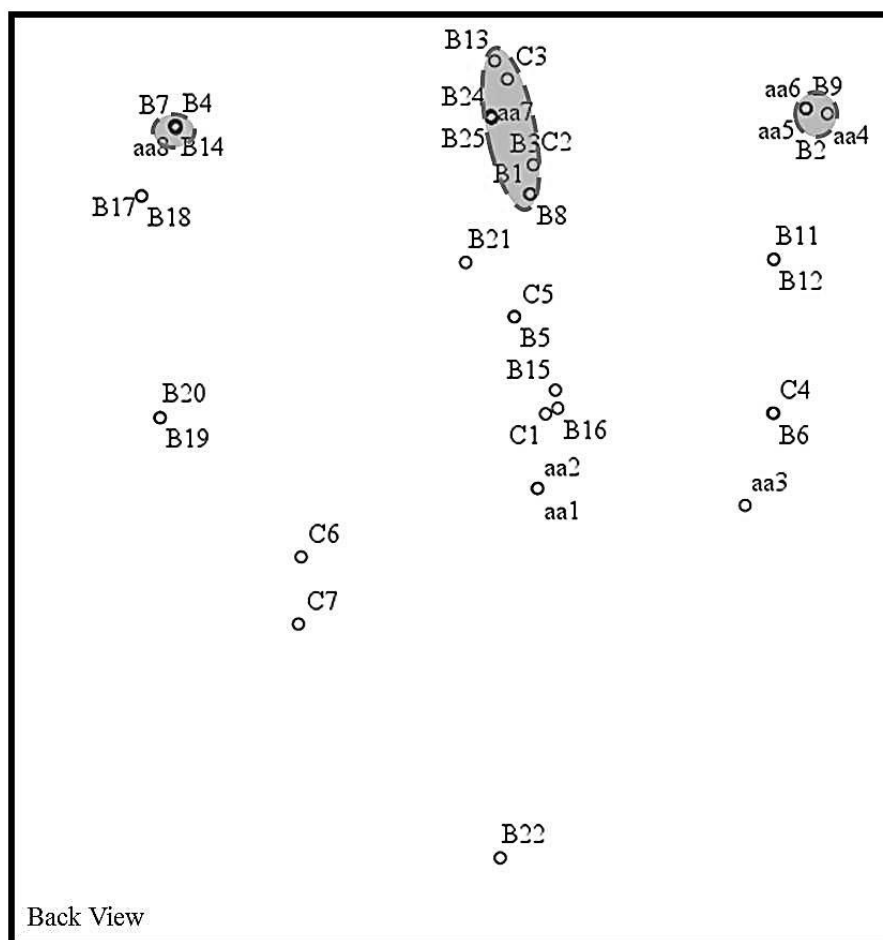

Figure 5.25 Part of the mapping results of Case 1 amended: using E_{15} .

Table 5.14 Combined tests of Case 1 amended: using E_{15} .

		Mapping results			Sensitivity and specificity	
		Conflict aa1;2; 5-8	No conflict aa3; 4	Total		
Patent attorney claim chart	Conflict 0	TP= 0	FN= 0	0	<i>Sensitivity = 0%</i>	
	No conflict aa1-8	FP= 6	TN= 2	8	<i>Specificity = 25%</i>	

5.5.4 Using E_{12b} in Case 1 Amended

The results are demonstrated in [Figure 5.26,27](#) and [Table 5.15](#).

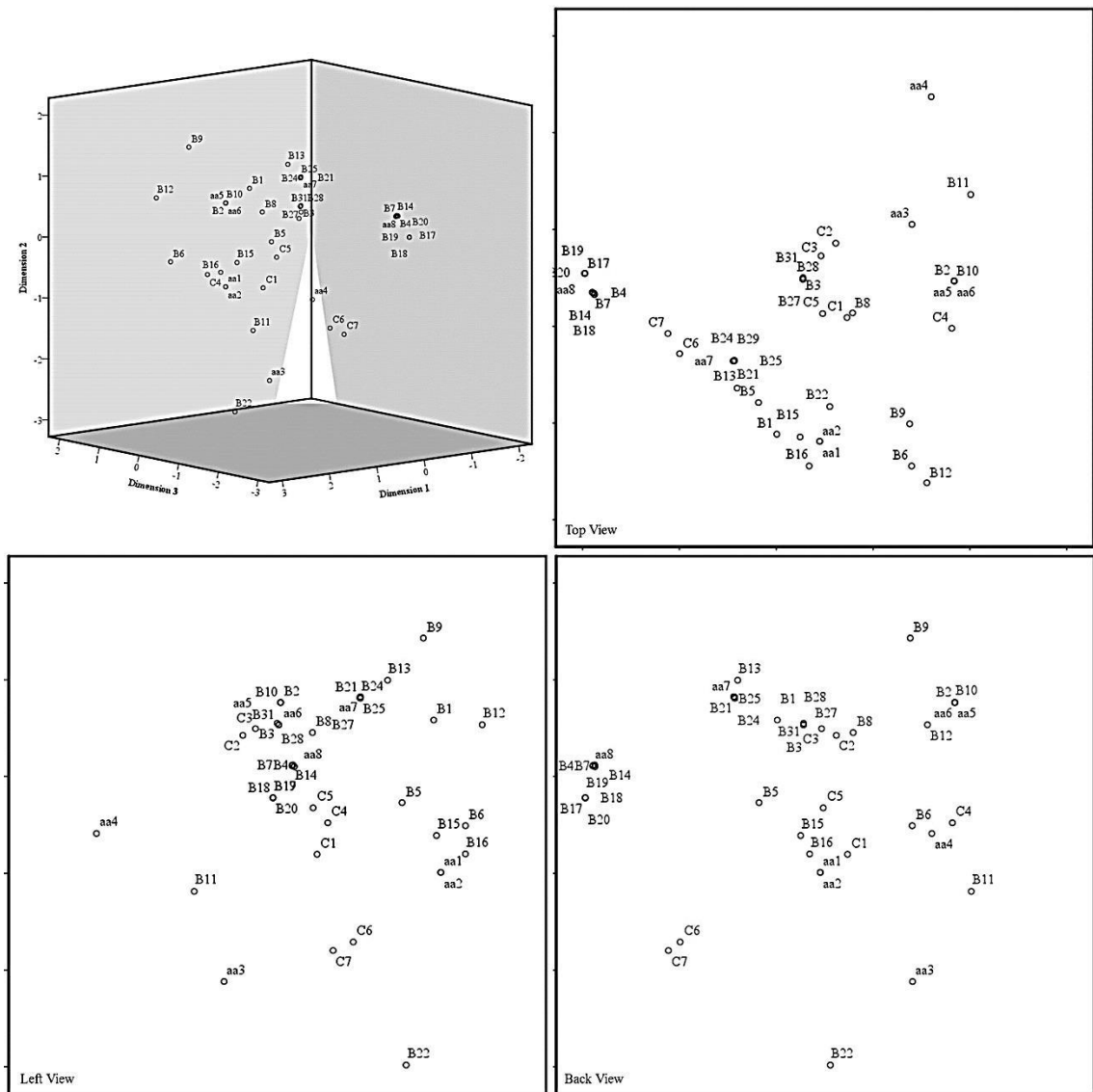

**Figure 5.26 Mapping results of Case 1 amended: using E_{12b} .
(Stress=0.16 and RSQ=0.89, from SPSS; an enlarged map is shown below)**

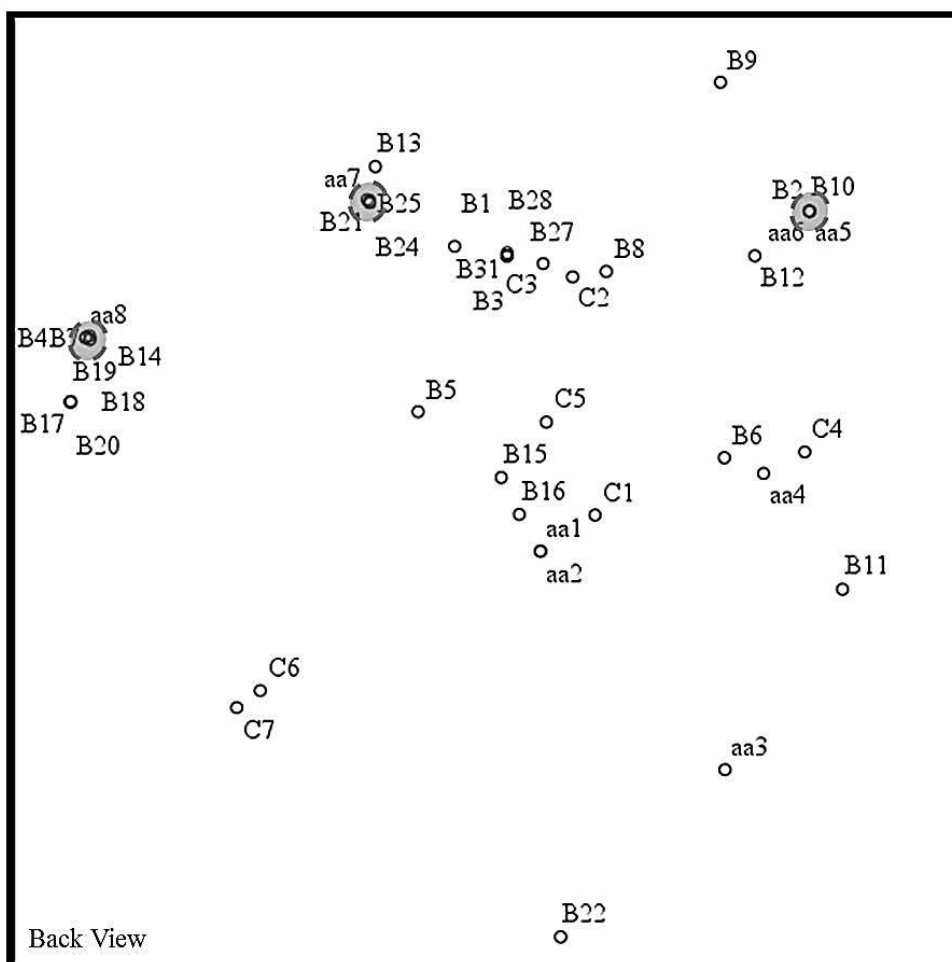

Figure 5.27 Part of the mapping results of Case 1 amended: using E_{12b} .

Table 5.15 Combined tests of Case 1 amended: using E_{12b} .

		Mapping results			Sensitivity and specificity	
		Conflict aa1; 2; 5-8	No conflict aa3; 4	Total		
Patent attorney claim chart	Conflict 0	TP= 0	FN= 0	0	<i>Sensitivity = 0%</i>	
	No conflict aa1-8	FP= 6	TN= 2	8	<i>Specificity = 25%</i>	

5.5.5 Improved E_k for Case 1 Amended

Based on the results above, the values of precision and accuracy are listed in [Table 5.16](#). The E_{15} and E_{12b} achieve higher accuracy, which are considered as the preferable criteria sets for Case 1 amended. But all of the precision values of three criteria sets are zero, which is further discussed in [Chapter 6](#).

Table 5.16 Precision and accuracy calculation for Case 1 amended.

Evaluation criteria sets	Compared with patent attorney's claim chart	
	Precision	Accuracy
E_{12}	0%	13%
E_{15}	0%	25%
E_{12b}	0%	25%

5.6 Statistical Precision

Seeing the results of precision and accuracy generated by E_{12} , E_{15} , and E_{12b} in the case studies above, the average values of precision can be calculated (Table 5.17).

Table 5.17 Average values of precision.

Cases	E_{12}	E_{15}	E_{12b}	Preferable set	
1	With EPO search report	100	100	100	E_{15}
	With UK court judgments	40	100	50	E_{15}
	With amended patent	0	0	0	E_{15} and E_{12b} (higher accuracy)
2	With UKIPO search report	60	60	67	E_{12b}
3	With UKIPO search report	0	0	0	E_{12} (higher accuracy)
4	With UK patent attorney	38	50	75	E_{12b}
Average		40	52	49	E_{15}

Seeing from the data above, the initial criteria set E_{12} is not of the highest precision. But at the beginning of implementation of the new method, the preferable set cannot be identified because of the lack of statistical precision values. Thus, improving criteria set is a process of abduction (Walton, 2001), meaning that former criteria can be replaced if latter ones produce better results. More discussions are stated in Chapter 6.

5.7 Summary of Chapter 5

Chapter 5 demonstrates more case studies of using the new method TRIZ-Led Patent Mapping to analyse patents in the field of mechanical engineering. As more results accumulate, a prediction based on statistical precision of the new method comes out, which is further discussed in the next chapter.

Chapter 6 Discussion

6.1 Introduction to Chapter 6

This chapter firstly shows the discussions on the selection of the criteria used in the new method; the average precision and prediction of probability are then interpreted; standards between different legal authorities are compared; the indices and admissibility for forming expert reports are discussed.

6.2 Evaluation Criteria

6.2.1 Finely Adjusting Evaluation Criteria

As the initial evaluation criteria set (E_{12}) had resulted in some missing and incorrectly identified claims in the mapping results, new criteria sets (E_{15} and E_{12b}) were developed by increasing either sensitivity or specificity of the initial set. The adjustments of criteria included deleting, combining, separating, and adding, which were made logically according to the associations of the physical or operational categories and on purpose of reducing the complexity in evaluation. These trial adjustments were examined by the combined tests of sensitivity and specificity.

6.2.2 Improved Evaluation Criteria Set

Seeing from [Table 5.17](#), the improved evaluation criteria sets can be found in the comparison of precisions (along with accuracy) in each patent case, i.e. the criteria set leading to higher precision is considered as preferred and improved; if precisions are the same (especially 0), then the criteria set that leads to higher accuracy is selected. Admittedly, preferable sets differ from cases because each patent contain different technologies. Nevertheless, an average precision among all the cases can be calculated, which is E_{15} with precision of 52%. As a result, E_{15} is statistically the fittest criteria set for all the four cases above.

Interestingly, there are two case studies that have 0 precision for all criteria sets. Such lack of precision is caused by the starting point of our new method: because the working hypothesis is that all mechanical inventions are potentially connected by virtue of sharing a commonwealth of working principles, therefore if legal judgments determine that there is no conflict then the TP value is 0 and consequently the precision of our method is 0 under these circumstances. In other words, all potential conflict claims identified by the new method are over-identified, i.e. too cautious and strict. However, in practice cautiousness is not unwelcome; it is also useful to count the cases with 0 precision in order to calculate an average precision for evaluating the effectiveness of the method.

6.3 Precision

6.3.1 Average Precision between Cases

The results in Table 5.17 can be transformed into Figure 6.1. Among the three statuses of Case 1, the result of the UK court judgment is chosen here.

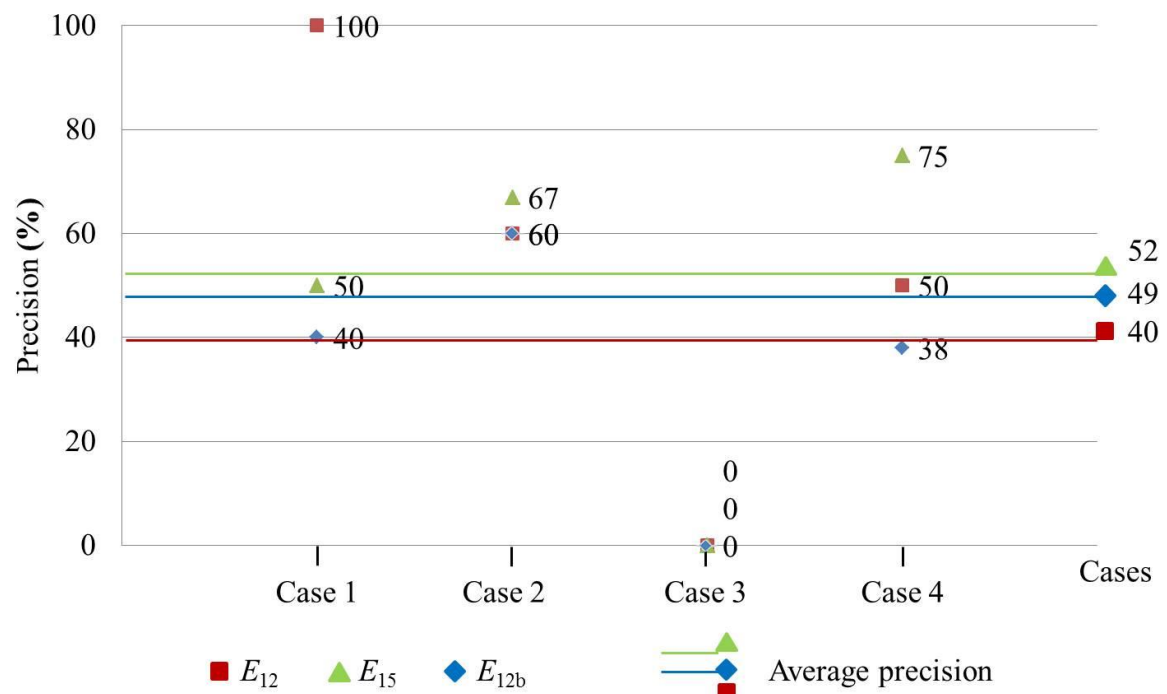

Figure 6.1 Statistical precision among cases.

6.3.2 Consequences of Precision for Prediction

The average precision lines shown in [Figure 6.1](#) represent the confidence level of using different criteria sets. The highest value of average precision is chosen, e.g. E_{15} with 52% precision, and this criterion set is adopted for future cases (new real cases without legal judgments). The logic in this paper is to use this criteria set as the best to go forward with for a future case until a better set is found, on the basis that such cases belong to the same field, i.e. mechanical engineering. Of course, this chosen criterion set may be a poor choice going forward to a new case and the method will therefore improve the criteria set.

6.4 Comparison of Legal Authority Standards

The values of sensitivity and specificity can be integrated into a Receiver Operating Characteristic (ROC) plot ([Fawcett, 2006](#)). The relationship between the legal judgments is represented as the points in ROC map ([Figure 6.2](#)), which has in effect used the mapping results as a benchmark in order to compare the legal judgments from the two authorities. Different points on the ROC plot reveal differences between legal authority standards (in Case 1, between EPO patent offices and UK courts). In other words, this map initially visualises the floating standard of **obviousness** assessment between authorities. Such differences, theoretically, as mentioned in s.2.2.3 are caused by the split of the judgments between administrative and judicial sections.

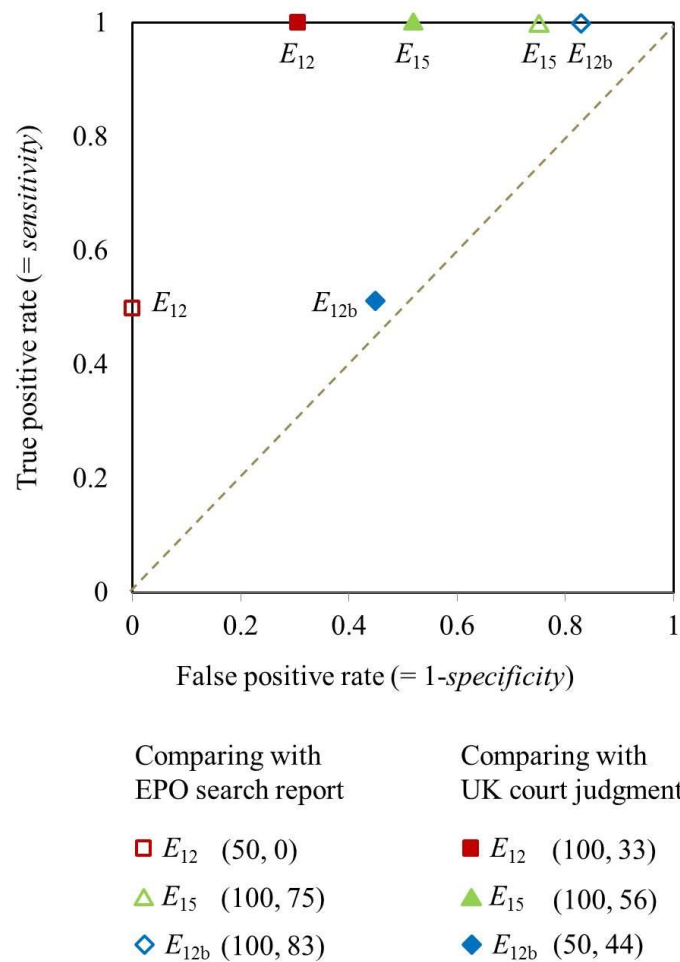

Figure 6.2 Comparing standards between legal authorities in Case 1 (ROC plot).

In addition, two points can be summarised:

- (1) Larger differences can be seen between the two legal authorities when using E_{12} or E_{12b} while for E_{15} the difference is relatively small. Therefore, E_{15} is considered as the better criteria set; and
- (2) The different standards between legal authorities can be explained as follows: technical reality is understood differently by different people under different circumstances. The method reveals the differences between legal assessment standards.

6.5 Alternative Statistical Methods

6.5.1 Relation of Criteria-Free and Criteria-Based MDS

Criteria-based (also called as attribute-based) data is adopted in the modelling, whereas previous researchers have used criteria-free (also, attribute-free) data. According to the literature (Black, Schulze, and Hughes, 2003; Sun et al.; 2011), there is scope for using criteria-based and/or criteria-free data as valid types of data input for MDS even though some prefer using criteria-free evaluation methods. However, using criteria-free data for patent maps will mean the user has to guess what the criteria are that form the basis of the plots viewed, resulting in ambiguous interpretation. The TRIZ parameters provide a sound technological basis for including criteria in the analysis.

6.5.2 Other Statistical Methods

An alternative statistical approach to clustering other than MDS is Hierarchical Clustering Analysis (HCA) (Hair, Tatham, and Black, 1995), which rather than generating a patent map based on direct pair-wise comparisons, the tree structure of HCA does not show isolated claims as clearly as MDS at the lower clustering levels.

There are statistical methods that could refine the 39 TRIZ parameters into a smaller set a posteriori, e.g., Principal Component Analysis (PCA). However, PCA is only a pure mathematical method for data processing (dimension reduction). The key to gaining a smaller set is not about how the number of criteria (parameters) is reduced but how the criteria (parameters) should be defined while the number is as small as possible for evaluation efficiency purpose. Thus, refining criteria has never been a pure mathematical data reduction. Such refining was not only achieved by reduction, but also by combining, adding, and separating. The determinant of refining criteria is the sensitivity and specificity tests, not the cumulative proportion in PCA. Consequently, PCA was not used for deciding a priori subsets of evaluation criteria. In addition, Singular Value Decomposition (SVD) was adopted for mathematical calculation purpose in the classic MDS (Torgerson, 1958) while SVD could be used for dimension reduction as finding cumulative rates in PCA.

6.6 Indices and Algorithm

6.6.1 Indices and Mission of Robustness

The indices in TRIZ-Led Patent Mapping are summarised in [Table 6.1](#):

Table 6.1 Indices of TRIZ-Led Patent Mapping.

Group	Symbol	Quality	Quantity
Patent	P_q	P =mechanical patents	q =number of patents
Criteria set	E_k	E =elements in criteria set (TRIZ parameters)	k =number of criteria
Claim	C_n	C =claims to be calculated/accumulated	n =number of claims
Evaluating	D_h	D =dissimilarity, i.e., evaluation results	h =number of evaluators
Mapping	V_t	V =MDS	t =time of iteration, Stress, RSQ.
Interpreting	R_u	R =degree of conflict, i.e., mapping results	u =number of unique claims
Fitness	F_w	F =degree of fitness	w =number of conflicted claims

The mission of robustness of TRIZ-Led Patent Mapping can be stated as: taking P_q as premised condition while V_t and C_n as constants, to seek reliable and valid E_k according to F_w in order to control E_k according to R_u to achieve lower sensitivity to noise D_h and higher precision (and accuracy) as a whole. Such a mission gives a direction for the future work.

6.6.2 Summary of Research Algorithm

The algorithm or logical framework of the research can be summarised in [Figure 6.3](#). It demonstrates the research problem identification, the step-by-step patent claim conflicts evaluation and visualisation, the precision calculation, and the comparison of authority standards. The logical flows are clarified by the arrows.

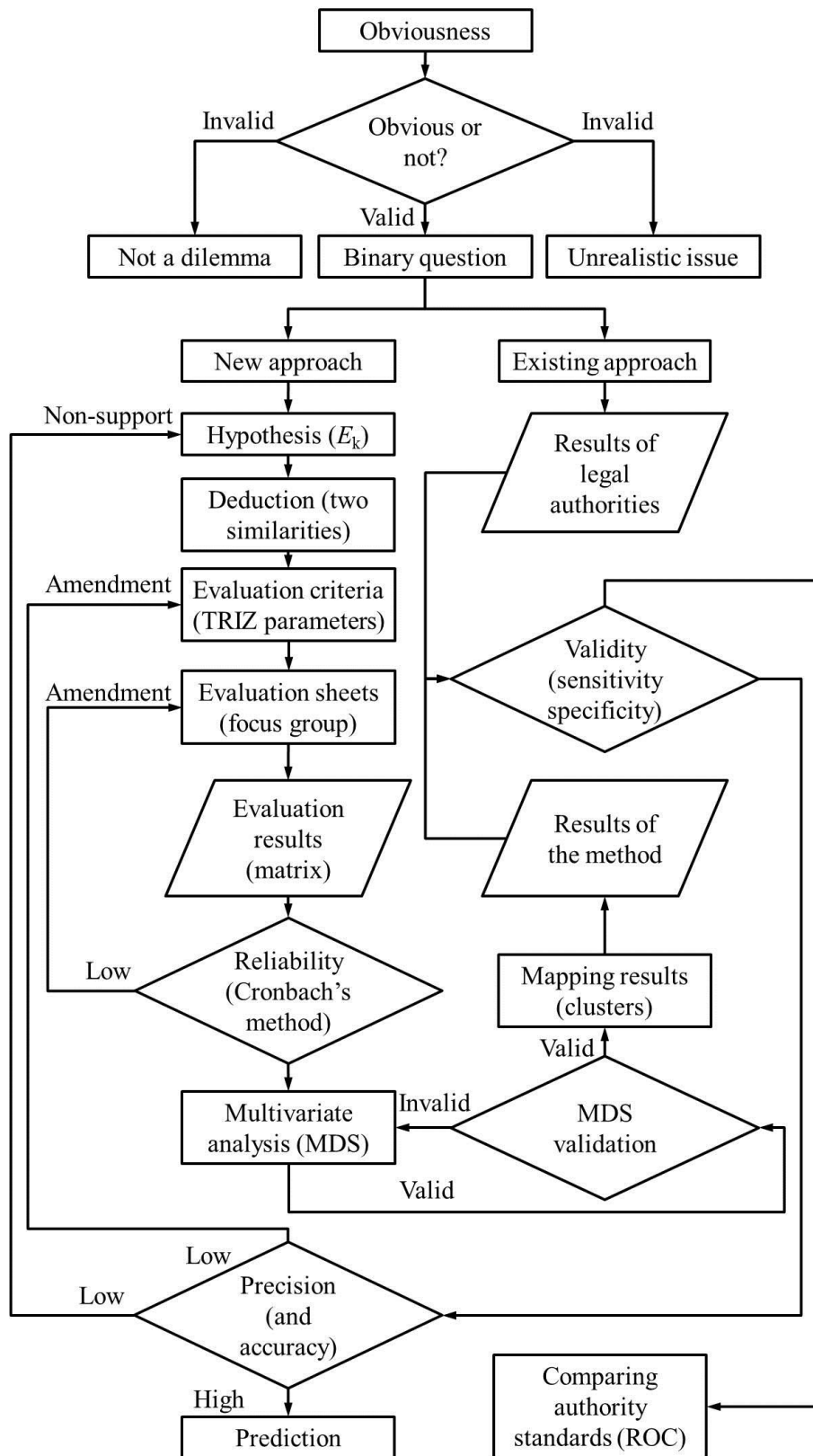

Figure 6.3 Summary of the algorithm of the research.

6.7 Advantages and Limitations

The practical advantage of the new method is mainly about time saving. TRIZ-Led Patent Mapping reduces evaluation complexity by transforming claim-to-claim comparisons into claim-to-criteria comparisons, which means that the new method saves time. This is not only a logical conclusion but has been tested by time costs comparison in practice but only according to approximate time calculation. Time is vital in patent applications and litigations. Thus, using less time while getting reasonable results, this is the main advantage of the new method.

Admittedly, achieving high efficiency of the method has to be balanced with the accuracy of results. The new method misidentifies conflicts between patent claims in comparison with those of facts (valid patents). Some possible reasons are:

- (1) The exclusion of basic information in patents, e.g., priority date and descriptions, which can lead to claim conflicts;
- (2) The system error leads to over-identification of conflict;
- (3) Using patent claims is an insufficient way to identify conflicts; and
- (4) The evaluation criteria are only statistically precise, which results in bias.

6.8 Legal Admissibility of the New Method

6.8.1 Conforming to the Existing Approach

TRIZ-Led Patent Mapping incorporates the restrictions of the **Windsurfing/Pozzoli approach**, i.e. each step described in [s.1.2.1](#). is followed in the new method. For instance, current patent text mining is mostly based on NLP ([Abbas, Zhang, and Khan, 2014](#)). However, NLP identifies and classifies words but does not convey meaning or infer the inventive concepts in patents, which determine that human evaluation is still necessary. The evaluators in all the case studies in this research are admissible skilled persons, including engineers in the partner companies, plus experienced researchers and

eight Year Three PhD students from Brunel University having background knowledge and experience of mechanical engineering. All of them read and understood the patents without explanation and they were not considered “*the leading experts*” or “*super-skilled*” (Reid, 1999: p.42-3) in the fields of the target patents. The evaluators were organised as focus groups, i.e. teams, also fitting the requirement in the existing approach of assessing **obviousness**. In the focus group evaluation, the short introduction to using the evaluation sheet to evaluate patent claims was done by the author. Eight evaluators were asked to answer this question: ‘Does this claim state something relevant with the parameters 1. Stability, 2. Length, 3. ...?’ If yes, then make a mark in the crossing blank in the evaluation sheet; if no, leave the place blank. Also, there is a short list of the explanations of TRIZ parameters provided to the evaluators (Appendix C). Besides, the time of evaluation was recorded on each evaluation sheet. There was no question of the boundaries of the Common General Knowledge in the evaluation. In summary, the new method fits the structure and requirements of the current approach.

6.8.2 Key Points for Forming Expert Reports

In patent litigation, expert reports are used by both sides for supporting their arguments of **obviousness**. TRIZ-Led Patent Mapping provides more scientific evidence that can be used in the **obviousness** assessment but whether it is admissible depends on two issues: firstly, whether the litigation parties agree with the reliability of the method (Glover and Murphy, 2013: p.410) and secondly, whether the courts permit the method to be used as legal evidence, see the [Civil Procedure Rules \(CPR\) Part 35](#) for more explanation. Some key points for forming an expert report are summarised below, assuming that this new method is permitted by courts and fact-finding tribunals. As each patent lawsuit has specific circumstances, there is no uniform way to produce an expert report but it is possible to generally describe some key points as in [Table 6.2](#). An example final legal conclusion is as follows:

Example final legal conclusion (the words with underlines are examples):

In the technical field of Mechanical Engineering and under the evaluation criteria of E₁₅, the evaluators, Smith and Jones (who are identified as skilled

persons), hereby declare 52% confidence that the claim A1 in the target patent A is obvious in comparison with the patents of B and C.

Table 6.2 Key points for writing up an expert report using TRIZ-Led Patent Mapping.

Key points	Descriptions
Example final legal conclusion	In the technical field of <u>Mechanical Engineering</u> and under the evaluation criteria of <u>E₁₅</u> , the evaluators, <u>Smith and Jones</u> , hereby declare <u>52%</u> confidence that the claim <u>A1</u> in the target patent <u>A</u> is obvious in comparison with the patents of <u>B and C</u> .
Competence of expert witnesses	Extent of evaluators' expertise, capable but not super-skilled; Is it a focus group (team) evaluation or individual evaluation? Is it conformity achieved in the group?
Weight of expert evidence	Are the elements of the inventive concept agreed by all the evaluators involved? Any controversial opinions in evaluations?

6.9 Proposal for A Third Way beyond Obviousness or Not

Up to this point there has been a focus on solving the dilemma of **obviousness** or not but in order to explore the kernel of the dilemma we propose a third way after reviewing the dilemma.

The new method in dealing with the dilemma of **obviousness** or not relies on the logic of reduction (understanding the system through its elements). Many scientific problems are successfully solved by reductive thinking, e.g. calculus, atomic theory, etc. and the modern integrated philosophical explanations of reduction can be found in Husserl's phenomenology which, simply stated, emphasised reduction methodology and nature of phenomenon (Wang, 2008: p.174-85). However, there is a core problem of reduction, which is, that the understanding provided by a reductive method is dependent upon the aggregation of the understanding of the constituent elements. In this research, the constituent elements of the inventive concept, although clearly defined, are highly abstract, which indicates that using reduction alone is inevitably more or less subjective. Moreover, a patent itself as a system not only involves natural sciences but also social sciences such as laws and economics, which again indicates that using reductive logic is not sufficient for solving patent issues. Reductive methods are a practical means for

obtaining a solution that can be improved upon, which is why it is adopted as the underlying logic in this research.

Based on the understanding of **obviousness**, a third way could replace the current theory and method as three levels:

- (1) A philosophical core based on ‘negation of negation of **obviousness**’, which is, in short, that the question is not about relationships (dissimilarity) of technologies in patents but mainly about to what extent readers of patents can understand and use the technologies and how difficult the technologies are to learn and imitate;
- (2) The development of a personality theory of patents ([Appendix B: p.113](#)) could be the theoretical framework as suggested by Fisher ([in Rao, 2008: p.90](#)); and
- (3) A specific practical approach could possibly emerge from combining the fluctuation curve of innovation (see Chapter 2) with duality of similarity (see Chapter 3), in order to address personal factors in both incremental innovation (gentle slope) and breakthrough innovation (steep slope). This is a direction for further research.

6.10 Summary of Chapter 6

The new method, validated by its precision values, is not a replacement of the existing **Windsurfing/Pozzoli approach**, but an attempt to achieve an alternative and supportive argument for enhancing judgments of **obviousness**. Hereby, the gap between legal approach, patent informatics and innovation theory (shown in Chapter 1) can be closed.

Chapter 7 Conclusion

7.1 Summary of Contents of Research

This research presents how elements of the inventive concept are linked to evaluation criteria. Based on these elements, an abstract inventive concept as stated in patent claims can be described so that differences between these claims can be measured and visually mapped into 3D graphs; whereby the complex legal notion of **obviousness** is represented as simply a distance between points. The elements are specified as the refined engineering parameters from the Theory of Inventive Problem Solving (**TRIZ**), which reduce evaluation complexity by transforming difficult claim-to-claim evaluations into simpler claim-to-criteria comparisons. Evaluation criteria can be finely adjusted for different patent cases in order to achieve higher precision of results.

A feedback process for evaluating claim conflicts has been established, which allows amendments of criteria to be guided by tests of sensitivity and specificity between the results of TRIZ-Led Patent Mapping and legal results such as search reports from patent offices and judgments from patent courts. Therefore, improved evaluation criteria have been found through iterating feedback until higher precision has been obtained as demonstrated in one case study. For further cases a statistical average precision is used to predict potential patent claim conflicts (probability of **obviousness**).

In practice, the new method uses focus groups in order to collect evaluation data to which Cronbach' method is applied to test consistency of evaluation results. Multi-Dimensional Scaling (**MDS**), a multivariate analysis method, is adopted for visualising evaluation results in a 3D map in which clustering is observed. A Receiver Operating Characteristic (ROC) graph is used for revealing differences between the judging standards of legal authorities.

Four case studies of implementing the method are presented, which are the patents of the adjustable aircraft seat, the nasal prong interface, the noise reduction device, and the metal enclosure. Three different sets of evaluation criteria are utilised for each case and

average precision among the four cases is obtained by virtue of evaluating sensitivity and specificity. The results of these case studies are linked to key points from expert reports.

7.2 Achieving Aim and Objectives

The general aim of the research has been achieved, i.e. a novel, scientific method for identifying, evaluating, and visualising patent conflicts. From this a tool has been designed, tested, and applied in real problems. Patent conflict identified by this TRIZ-Led Patent Mapping method has been evaluated for patent claims (assessing **obviousness**). In summary, the research objectives have been met successfully, as follows:

- (1) Using dialectical analysis, the research problem and its premises have been identified and discussed as the dilemma of **obviousness**;
- (2) Through abstraction and reasoning of definitions and contexts of **obviousness**, this legal term has been clarified and the insufficiency in the argument for **obviousness** has been revealed;
- (3) The current approach to assessing **obviousness** (evaluating patent claim conflicts) is analysed step-by-step; patent mapping and TRIZ have been studied and linked with the design of the new method;
- (4) The relevant methods of patent life cycle models and innovation have been checked and used as inspirations for proposing “the third answer”;
- (5) Mathematical modelling of evaluating patent claim conflicts has been demonstrated in terms of evaluation criteria that transform the inventive concept from intangible ideas into clustering of points in 3D maps;
- (6) A feedback process for iterative precision validation has been shown through comparing results of the new method with results from legal authorities; and

(7) The new method has been applied to four case studies, and different criteria sets have been tested for their precision and accuracy. The potential claim conflicts (probability of **obviousness**) have been evaluated.

7.3 Contributions of Research

There are three contributions of this research:

- (1) The main contribution of this research is that it establishes a new patent mapping method that is based upon efficient evaluation criteria, which clearly identify conflicts between patent claims.
- (2) The new method successfully interprets the inventive concept inherent in the legal **obviousness** assessment specified by refined TRIZ parameters.
- (3) The new method links patent conflicts with legal **obviousness** that gives legal meaning to evaluating technical differences (or similarity) between patent claims, which is not achieved by existing patent mapping methods.

Therefore, assessing **obviousness** becomes an open and transparent procedure which can be used by engineers and designers to relate to legal authorities.

7.4 Future Work

There are three suggestions for further research:

- (1) Develop other statistical methods for visualising similarity of data.
- (2) Carry out more case studies for the combined tests of sensitivity and specificity in order to select improved criteria sets and reach better agreement with legal judgments. This requires developing more efficient informatics tools.
- (3) Evaluate the new method in terms of the proof of admissibility and form a more detailed evaluation of expert reports.

Appendix A: Definition, Contexts, and Assessment Approach of Obviousness

Clarifying **obviousness** and its contexts is a vital step of this research. Presenting the clarification in the appendix here not in Chapter 1 is for purpose of typesetting, or Chapter 1 would be too long and the topic may seem to be apt to legal field.

The clarification of **obviousness** indicates the understanding of legal background, which is the shortage of TRIZ and patent mapping that causes the lack of legal admissibility of both of these methods (admittedly, the purposes of these two methods are originally different from assessing **obviousness**). The following clarification is not only a simple integration of legal terminologies and statements but a systematic synthesis and critical discrimination of the mosaic pieces of the definitions and explanations of **obviousness** which are chaotically scattered in the existing UK laws, regulations, judgments, and research papers.

Definitions of Obviousness

Obviousness reads in the [Patents Act 1977 s.3](#) as “*An invention shall be taken to involve an inventive step if it is not obvious to a person skilled in the art*”. The definition of **obviousness** is clarified and synthesised as six points as following:

- (1) Its literal definition, i.e. semantic meaning, is a state of perception of “conceptually apparent without substantial research to any expert in the field”, ([OED, 2014](#)), “*readily perceived by the eye or the intellect, clear, and evident*” ([Black, 1968: 1229](#)); in short, “unessential differences” ([Kemp, 1983: 19-25](#));
- (2) Its etymological definition comes from “*obvious = ob + vi(a) + ous*”, meaning “*in the way*” (*via* means way), “*presenting itself to the mind or senses, ready to hand*” ([OED, 2014](#));
- (3) Logically, its substantial definition is a part-whole not generic-specific relationship property between patent claims (usually between different patents);

(4) Its genetic definition is provided in qualitative, structured approach, called the **Windsurfing/Pozzoli approach**, see the *Pozzoli SPA v BDMO SA* [2007] EWCA Civ 588;

(5) Its functional definition refers to the second legal element of patentability, necessary but not sufficient condition of validity of patents and doctrine of equivalency for patent infringements (Kemp, 1983: 19-25); and

(6) Philosophically, **obviousness** is the positive stage of contradiction (still being self); **non-obviousness** is, on the contrary, the negative stage, (not self-position anymore but completed self-negation). Thus, **obviousness** belongs to the category of quantity and quality, i.e. accumulation of quantitative steps (**obviousness**) leads to a qualitative leap (non- **obviousness**).

Historically, the first relevant regulation of invalidity by **obviousness** in the UK was the “*revocation on the ground of obviousness...codified in the 1932 Act*” (Miller et al., 2010: s.12-02). The *Patents Act 1949 s.32(1)(f)* provided that a patent was liable to be revoked on the ground:

“that the invention, so far as claimed in any claim of the complete specification, is obvious and does not involve any inventive step having regard to what was known or used, before the priority date of the claim, in the United Kingdom”.

Contexts of Obviousness

The modern UK law of patents refers to the *UK Patents Act 1977* (Miller et al., 2010: s.1-42) enforced since 1 June 1978, amended up to and including 1 June 2014 in the United Kingdom of Great Britain and Northern Ireland, which is regulated by:

- (1) The *Patents Rules 2007*, pursuant to powers in the 1997 Act;
- (2) The *Civil Procedure Rules*; and
- (3) The *Patents Court Guide*.

It has been taken the same effect as the corresponding provisions of “inventive step” in the [European Patent Convention \(EPC\) 1973 Article 56](#); the [Patent Cooperation Treaty \(PCT\) 1970](#); the [Community Patent Convention \(CPC\) 1975-89](#) (Burrows, 2013: s.6.18); and also as the similar terms of “non-obvious” in the [America Invents Act \(AIA\) 2011 s.103](#); “inventiveness” in [China Patent Law 2008 s.2-22](#); “easily made” in [Japan Patent Act 1959 Article 29\(2\)](#); as well as in [Korean Patent Act 1997 Article 29\(2\)](#).

Patent claims are described in the [Patents Act 1977 s.14\(5\)](#) and [EPC Rule 43\(1\)](#), which are explained in details as following:

- (1) They are delimitations of protection afforded by patents, i.e. scope of exclusive (monopoly) rights ([Miller et al., 2010: s.1-20](#); [Drahos, 1996: p.14](#));
- (2) They are generalisations of matters of an invention ([Kemp, 1983: p.10](#)) and embodiments of inventive concepts;
- (3) They are, see in the [Virgin v Zodiac \[2013\] UKSC 46 paragraph 5](#), explained and clarified by descriptions and drawings in patents, which determine contexts of claims; meanwhile, literally determined by meanings of terms and are essentially determined by patentee’s purpose;
- (4) They can be categorised as independent claims (previous or antecedent claims) and dependent claims (sub-claims or subsidiary claims). As explained in [Patent Teaching Kit PC 9](#), if an independent claim is invalid, its dependent claims may still be valid. Thus, it is a part-whole relationship between dependent-independent claims;
- (5) They can also be categorised as method claims and apparatus claims, which is usually a generic-specific relationship because apparatus claims are usually specific applications of method claims in a patent. This means that considering apparatus claims only is sufficient in **obviousness** assessment; and
- (6) They can be divided as two parts in drafting as pre-characterising part and characterising part, however, cannot be separately interpreted for **obviousness**

assessment, i.e. “*when considering **obviousness** you must look at the claim as a whole*”, see in the [Virgin v Zodiac \[2013\] UKSC 46 paragraph 9-22](#).

An inventive concept is “the idea or principle...to be called inventive”, i.e. core of invention, specified in the [Manual of Patent Practice \(MoPP\) 2014 s.3.03, 3.34-5](#). The [Allergan Inc v Sandoz Canada Inc 2011 FC 1316: 57](#) also gave suggestions to discern inventive concept: “to ‘ascertain the nature of the invention’ that is articulated in the claims”. Besides, an inventive concept is “of at least equivalent breadth” to patent claims.

The meaning of inventive step, which is the second condition of patentability in the Patents Act 1977 s.1(1)(b), is explained by the [Genentech Inc’s Patent \[1989\] RPC 147 \(CA\) 153](#) and summarised here as an activity of inventing that refers to a holistic process of invention, from setting goals to producing solutions.

Patentability mainly consists of three requirements according to the [Patents Act 1977 s.1-4A](#), which are novelty, inventive step, and industrial application.

Validity of patents refers to the requirements of a valid patent such as the restrictions of applicants, the conditions of patentability, and regions of protection, etc. ([Miller et al., 2010: s.1-80](#)). In this research, these requirements of validity of patents can be simply divided into two parts: the requirement of **obviousness**, and the other requirements.

Technical features are specific unites of technologies stated in a patent claim. Special technical features, not mainly emphasised in the UK but commonly seen in the EPC, are explained in the EPC Rule 44 and Art 82:

“The expression ‘special technical features’ means, in any one claim, the particular technical feature or features that define a contribution that the claimed invention considered as a whole makes over the prior art.”

This definition means that special technical features exist in patent claims. Here, special technical features and **obviousness** are understood as two forms of the same content: respectively, attributes of patent claims and relationship between patent claims.

Windsurfing/Pozzoli Approach

The **Windsurfing/Pozzoli approach**, see the [Pozzoli SPA v BDMO SA \[2007\] EWCA Civ 588](#), is the current admissible way to assessment of **obviousness**. The whole content of the approach is listed below:

“(1)(a) Identify the notional ‘person skilled in the art’;

(1)(b) Identify the relevant common general knowledge of that person;

(2) Identify the inventive concept of the claim in question or if that cannot readily be done, construe it;

(3) Identify what, if any, differences exist between the matter cited as forming part of the ‘state of the art’ and the inventive concept of the claim or the claim as construed;

(4) Viewed without any knowledge of the alleged invention as claimed, do those differences constitute steps which would have been obvious to the person skilled in the art or do they require any degree of invention?”

Hence, the **Windsurfing/Pozzoli approach** is based on the skilled person and the Common General Knowledge (CGK) in order to identify differences which lead to the decision making of obvious or not.

Person skilled in the art, or the skilled person, summarised from the explanations in the [MoPP 2014 s.3.20-8](#), refers to:

(1) Someone who is good at their job, a fully-competent worker, assumed to be at least sufficiently interested to address his/her mind to the subject and to consider the practical application of the information which he/she is deemed to have; meanwhile, not a highly skilled expert or a Nobel prize winner, nor lowest common denominator; and

- (2) A team composed of skilled persons from each of the relevant fields because expert advice in another field may be sought, no matter whether they work together as a single unit or as sub-contractors.

Common General Knowledge (CGK) is the knowledge making the skilled person skilled. It is a relative concept, a set of organised information, that can be summarised as a part of the mental equipment or mental toolkit needed so as to be competent in the art concerned, e.g.:

- (1) A set of industry standards, see in *Nokia v Ipcom* [2010] EWHC 3482;
- (2) Unconventional knowledge, see in *Apimed Medical Honey Ltd v Brightwake Ltd* [2011] EWPC 2, [2011] RPC 16;
- (3) Public knowledge such as journals and papers. However, publications may not be CGK, see in *General Tire & Rubber Co v Firestone Tyre & Rubber Co Ltd* [1972] RPC 457; and
- (4) Any information that is proved as a matter of routine can be considered for **obviousness** assessment, see the *KCI Licensing Inc & Ors v Smith & Nephew Plc & Ors* [2010] EWCA Civ 1260.

Moreover, other discussions for assessing **obviousness** along with the use of the **Windsurfing/Pozzoli approach** are summarised below, and can be further found at “Terrell on the Law of Patents” and “CIPA Guide” in the [MoPP 2014 s.3.19](#).

- (1) Commercial considerations should not be totally ignored in **obviousness** assessment, which was emphasised in the *Dyson Appliances Ltd v Hoover Ltd* [2002] RPC 22 and the [MoPP 2014 s.3.25](#);
- (2) A combination or a collection of technologies, i.e. technical collocations, is specially considered by skilled person with CGK, referring to distinguishing isolating or synergic functions of technical features, see the *SABAF SpA v MFI*

Furniture Centres Ltd [2005] RPC 10 and European Patent Office (EPO) Technical Board of Appeal (TBA) decision in T 1054/05 paragraph 4.5; and

(3) The discussion in *Conor v Angiotech* [2006] RPC 28 paragraph 37 shows the relationship between anticipation and **obviousness** that:

“... it is essential to remember that the objection of obviousness is available even when the invention is not anticipated... it is important to guard against the suggestion that lack of anticipation is in itself an indication of non-obviousness in the technically objective sense”.

This means that if the invention is anticipated, then it could be non-obvious; if it is not anticipated, it could also be non-obvious. Hence, anticipation cannot be a sufficient condition to **non-obviousness**.

There are other approaches by other authorities out of the UK patent system, such as the Problem-Solution Approach (PSA) in the European patent system stated in [EPC Article 52,56](#), and the Teaching-Suggestion-Motivation (TSM) test in the US patent system, stated in the *KSR Int'l Co. v. Teleflex, Inc.*, 2007 550 US 398.

To summary the **Windsurfing/Pozzoli approach**, **obviousness** is decided by analysing difference. Even subjectivity is reduced to the largest extent (e.g. identifying and unifying certain person and CGK), a decision is still a disputable paradox, because **obviousness** is seen as a default concept (being self) while **non-obviousness** is a stage of **obviousness**. Assessing **obviousness** is either seeking similarity in difference or confirming difference among the similar.

Appendix B: Legal Basis and Brief History of Intellectual Property

Legal Basis: Four Theories of IP

As a form of Intellectual Property (IP), a patent is a kind of property, an intangible asset, and then become a right, meaning that it also has its root in the economic field. In fact, philosophically, occupation of property or asset is the basis of right (law).

IP is usually considered as a private right (a right to private property, opposite to a public right) and generally includes four subsets: copyrights, patents, trademarks, and other forms (Christie and Gare, 2012). Intellectual Property Right (IPR) is, essentially, a duty-bearing, state-based monopolistic privilege (Drahos, 1996). A patent is an IPR and accordingly contains such connotation.

There are four major perspectives currently dominating the theoretical bases of IPR: utilitarianism, labour theory, personality theory, and social planning theory (Rao, 2008: p.37-115). The contents of these four theories are summarised here in Table B.1 for gaining an insight of the big picture of patents.

Table B.1 Theories of fundamental of IP.

	Logic	Premises or hypotheses	Pros	Cons
Utilitarianism	IPs, as useful contributions, should be awarded in order to compensate risks of easily-duplicated and stimulate trials through limited monopoly rights based on disclosing IPs to the public. Thus, IP system is designed for maximising social welfares with	IPRs can be clearly identified and measured; Knowledge defined by IPRs should be accessible and understandable to all; Pursuing social welfares may scarify individual benefits.	Adopting market incentive mechanism and cost-profits analysis can clearly identify IP production and application.	Difficult to measure social welfares and lack of experience data of social welfares; Difficult to keep incentive mechanism effectively operating. Monopoly may affect social welfare; Only focusing on

	minimum social costs.			<p>results, not creative nor innovative processes;</p> <p>Monopoly is just one way to stimulate IP production, not the only or most effective way;</p> <p>Negative economic effects may be caused by stopping 'reinvent the wheel', i.e., IPRs may hinder trials of technical improvements.</p>
Labour Theory	<p>As people have ownerships of their bodies, they own their labours that done by their bodies. So it is the same that they have rights of outcomes from their labours. IPRs are not only property rights but also moral rewards for those who have put labours into resources.</p>	<p>Locke's premise: equally opportunities to create and abilities of using prior arts;</p> <p>Resources are owned naturally by everyone;</p> <p>One gains what he/she sows. One should not get other's fruits.</p>	<p>IPRs are not only legal rights or property rights, but moral rights;</p> <p>Human labour adds new values into resources.</p>	<p>Information in IPs cannot be understood by everyone but only understandable to some experts, i.e., although opportunities of attaining information in IPs are equal to all, understanding and explanation rights are not equal at all;</p> <p>Resources are not owned by all;</p> <p>Sow-gain process is a cycle, a sub-system of bigger system. One's sowing is based on others' gaining. It is not unbalanced to merely emphasise sub-system without considering bigger system.</p>
Personality Theory	<p>Artificialities cannot exist without creators' personalities, including creativity, imagination, technical</p>	<p>Personality exists in artificialities;</p> <p>Validity of property rights relies on</p>	<p>Personalities exist in artificialities, which is a fundamental and necessary condition of validity of</p>	<p>Some confusions of ownerships of re-creation;</p> <p>Some confusions of ownerships of those passed-away</p>

	cultivation, dedication, etc. IPR is a sublation of subjectivity, which is an absolute right, equal to rationality.	personalities; Those personalities involved in artificialities exist with the artificialities for ever.	existence of artificialities; Personal spirits can be protected; IPRs transformation is based on copies, not original artificialities initially created by owners.	creators.
Social Planning Theory	IPRs indicate a kind of labour alienation, social relationships, and ideological functions. Thus, constructing IP regime means shaping an entire social framework and social relationships within, in order to achieve democratic civil society.	There will be a good but, to some extent, unrealistic society where majority can benefit from regime design.	Individual liberty and properties are respected as a claim in social structure making; Leading people to think of IPRs' political functions; Aiming at a democratic, authority-free, and diverse society.	A purpose-guided, i.e., Teleology; Unrealistic.

From the literature, one common point is that each legal basis is appropriate to justify one or two aspects of intellectual property rights but weak in supporting other aspects. For instance, arts and literatures reflect creators' emotions, imaginations, and dedications, which are formed as copyrights according to personality theory that is perfect for proving validity of these human personalities. However, in engineering design, an invention is of more objective contents, rather than personal characteristics. For technical inventions, personality theory may seem not that proper than labour theory. It often happens that one artificiality is of legal property rights from one or two perspectives of the four but not sufficient supported by the others. Controversial lawsuit cases happened in the history, such as the case *Feist Publications, Inc., v. Rural Telephone Service Co.* 1991 499 US 340. In addition, utilitarianism emphasizes market mechanism while social planning theory aims at political significance of IPR mechanism.

To summarise these four theories, it has been found that there are two reasons of contradictions and shortages of each legal basis. One is the neglect of diversity of artificialities - artificialities are objectively of different categories and various features. Legal definitions of property rights for different artificialities should not and cannot be the same. The other one is the confusion of rationality of the existence of IPRs and the rationality of rewards mechanism based on IPRs. Generating IP is extension of human bodies, where labour and personality theories are of predominance; as an objective, independent artificiality outside of its creator, IP is a social thing and IPR is of legal features of general property rights, where utilitarianism and social planning theory plays the key role. Therefore, it is easy to be biased and mistaken in thinking of IPRs when omitting specific artificiality and the real use of property rights. Artificialities are alien from their makers since they were created. Once this fact is omitted, the legal bases will no longer be solid.

Brief History of IP

IPR is a historical category, meaning that it has a beginning and will have an end. The first recorded restrictions on unauthorised copying of books and certain other types of work beginning with an edict of the Emperor can be tracked back from A.D. 835, China, during the Tang dynasty ([Burrell in Bently and Maniatis, 1998, p.200](#)).

However, the history of IP law does not begin with statute but evolved out of a complex system of prerogative, privilege and monopoly ([Drahos, 1996, p.14](#)). That “complex system” means or indicates that transferring parts of monarchical powers to the public. So the model of modern IP system was a distribution mechanism to delimit private rights with equivalent duties. English law came to invent the category of abstract object learnt from Roman law. “Intellectual property” is a twentieth-century generic term used to refer to a group of legal regimes which began their existence independently of each other at different times and places.

The first formalised patent system was developed in the fifteenth century in Venice and at that moment, intellectual property was born ([May and Sell, 2006, p.58](#)). England is often given the credit for having the first copyright statute, the Act of Anne of 1709.

The Venetians are thought to have had the first patent statute. Since 1995, IP rights have been subject to the TRIPs agreement, which is overseen by the WTO ([May & Sell, 2006, p.4](#))¹⁰.

During the past decades, international IP laws and treaties such as Patent Cooperative Treaty (PCT), Hague System for industrial designs, Madrid System for trademarks, and Berne Convention for copyright were established as basic rules.

There is a global IP organisation called the World Intellectual Property Organisation (WIPO), which has involved 187 of the total 193 members in the United Nation (UN) ([WIPO, 2014](#)). IPR system, as a law-depended mechanism of power ([Drahos, 1996, p.149](#)), is still playing a crucial role in today's knowledge economy.

Appendix C: 39 TRIZ Engineering Parameters

Table C.1 TRIZ parameters and their explanations (Gadd, 2011).

No.	Title	Explanation
1	Weight of moving object	The mass of the object, in a gravitational field. The force that the body exerts on its support or suspension.
2	Weight of stationary object	The mass of the object, in a gravitational field. The force that the body exerts on its support or suspension, or on the surface on which it rests.
3	Length of moving object	Any one linear dimension, not necessarily the longest, is considered a length.
4	Length of stationary object	Same.
5	Area of moving object	A geometrical characteristic described by the part of a plane enclosed by a line. The part of a surface occupied by the object. OR the square measure of the surface, either internal or external, of an object.
6	Area of stationary object	Same
7	Volume of moving object	The cubic measure of space occupied by the object. Length x width x height for a rectangular object, height x area for a cylinder, etc.
8	Volume of stationary object	Same
9	Speed	The velocity of an object; the rate of a process or action in time.
10	Force	Force measures the interaction between systems. In Newtonian physics, force = mass X acceleration. In TRIZ, force is any interaction that is intended to change an object's condition.
11	Stress or pressure	Force per unit area. Also, tension.
12	Shape	The external contours, appearance of a system.
13	Stability of the object's composition	The wholeness or integrity of the system; the relationship of the system's constituent elements. Wear, chemical decomposition, and disassembly are all decreases in stability. Increasing entropy is decreasing stability.
14	Strength	The extent to which the object is able to resist changing in response to force. Resistance to breaking.
15	Duration of action by a moving object	The time that the object can perform the action. Service life. Mean time between failure is a measure of the duration of

		action. Also, durability.
16	Duration of action by a stationary object	Same.
17	Temperature	The thermal condition of the object or system. Loosely includes other thermal parameters, such as heat capacity, that affect the rate of change of temperature.
18	Illumination intensity	Light flux per unit area, also any other illumination characteristics of the system such as brightness, light quality, etc..
19	Use of energy by moving object	The measure of the object's capacity for doing work. In classical mechanics, Energy is the product of force times distance. This includes the use of energy provided by the super-system (such as electrical energy or heat.) Energy required to do a particular job.
20	Use of energy by stationary object	Same.
21	Power	The time rate at which work is performed. The rate of use of energy.
22	Loss of Energy	Use of energy that does not contribute to the job being done. See 19. Reducing the loss of energy sometimes requires different techniques from improving the use of energy, which is why this is a separate category.
23	Loss of substance	Partial or complete, permanent or temporary, loss of some of a system's materials, substances, parts, or subsystems.
24	Loss of Information	Partial or complete, permanent or temporary, loss of data or access to data in or by a system. Frequently includes sensory data such as aroma, texture, etc.
25	Loss of Time	Time is the duration of an activity. Improving the loss of time means reducing the time taken for the activity. "Cycle time reduction" is a common term.
26	Quantity of substance/the matter	The number or amount of a system's materials, substances, parts or subsystems which might be changed fully or partially, permanently or temporarily.
27	Reliability	A system's ability to perform its intended functions in predictable ways and conditions.
28	Measurement accuracy	The closeness of the measured value to the actual value of a property of a system. Reducing the error in a measurement increases the accuracy of the measurement.
29	Manufacturing precision	The extent to which the actual characteristics of the system or object match the specified or required characteristics.

30	External harm affects the object	Susceptibility of a system to externally generated (harmful) effects.
31	Object-generated harmful factors	A harmful effect is one that reduces the efficiency or quality of the functioning of the object or system. These harmful effects are generated by the object or system, as part of its operation.
32	Ease of manufacture	The degree of facility, comfort or effortlessness in manufacturing or fabricating the object/system.
33	Ease of operation	Simplicity: The process is NOT easy if it requires a large number of people, large number of steps in the operation, needs special tools, etc. "Hard" processes have low yield and "easy" process have high yield; they are easy to do right.
34	Ease of repair	Quality characteristics such as convenience, comfort, simplicity, and time to repair faults, failures, or defects in a system.
35	Adaptability or versatility	The extent to which a system/object positively responds to external changes. Also, a system that can be used in multiple ways for under a variety of circumstances.
36	Device complexity	The number and diversity of elements and element interrelationships within a system. The user may be an element of the system that increases the complexity. The difficulty of mastering the system is a measure of its complexity.
37	Difficulty of detecting and measuring	Measuring or monitoring systems that are complex, costly, require much time and labour to set up and use or that have complex relationships between components or components that interfere with each other all demonstrate "difficulty of detecting and measuring." Increasing cost of measuring to a satisfactory error is also a sign of increased difficulty of measuring.
38	Extent of automation	The extent to which a system or object performs its functions without human interface. The lowest level of automation is the use of a manually operated tool. For intermediate levels, humans program the tool, observe its operation, and interrupt or re-program as needed. For the highest level, the machine senses the operation needed, programs itself, and monitors its own operations.
39	Productivity	The number of functions or operations performed by a system per unit time. The time for a unit function or operation. The output per unit time, or the cost per unit output.

Appendix D: Refining TRIZ Parameters

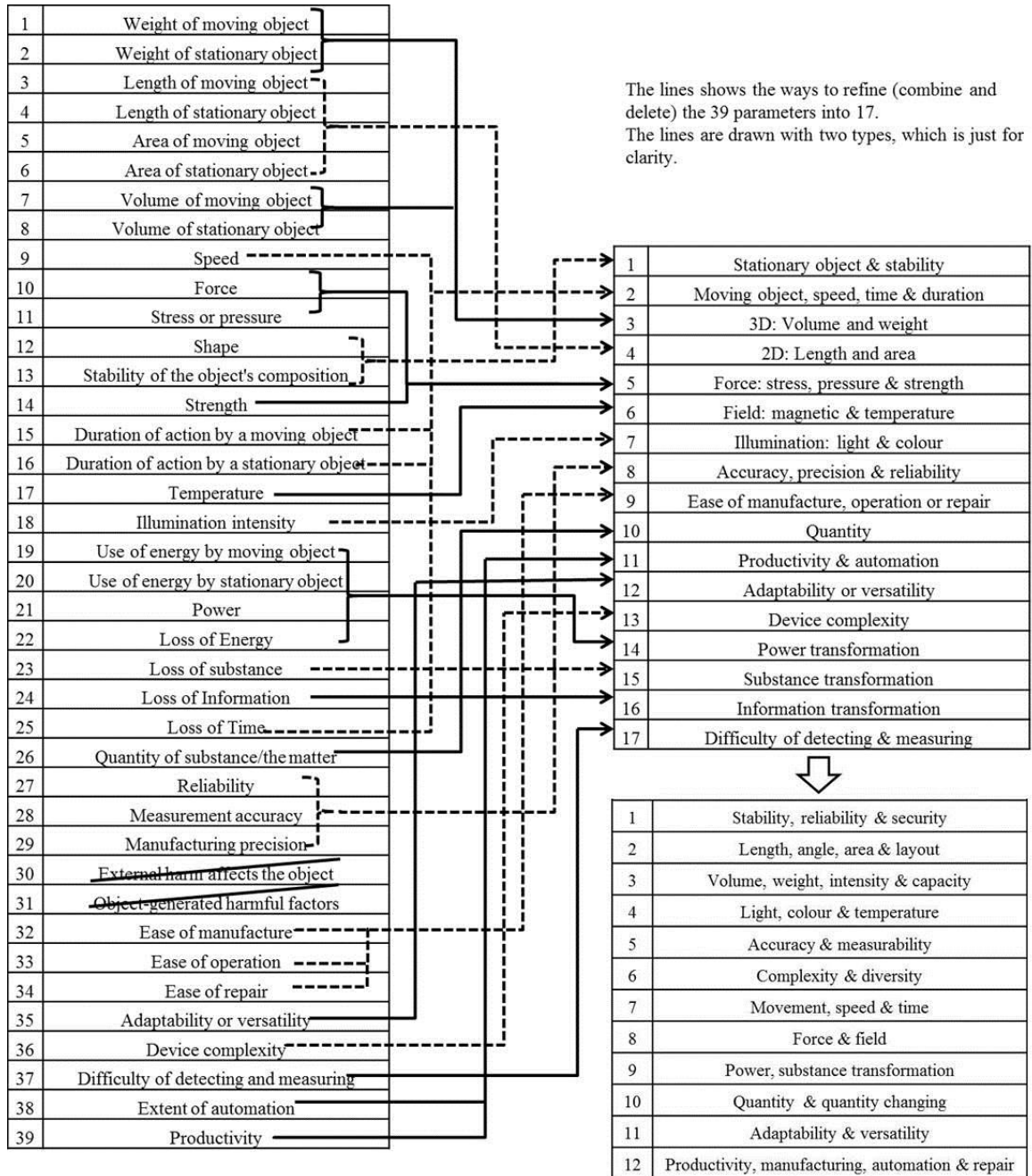

Figure D.1 Refining TRIZ parameters: from 39 to 17 and then to 12.

Appendix E: Consistency of Evaluation Results

Table E.1 Consistency of evaluation results between using different sets of evaluation criteria in Case 4.

	D_{23}^*	D_{24}	D_{25}	D_{26}	D_{27}	D_{28}	D_{29}	D_{34}	D_{35}	D_{36}	D_{37}	D_{38}	D_{39}	D_{45}	D_{46}	D_{47}	D_{48}	D_{49}	D_{56}	D_{57}	D_{58}	D_{59}	D_{67}	D_{68}	D_{69}	D_{78}	D_{79}	D_{89}
E_{39}	0.23	0.60	0.40	0.40	0.50	0.50	0.64	0.56	0.56	0.56	0.64	0.64	0.60	0.67	0.00	0.75	0.75	0.43	0.00	0.25	0.25	0.43	0.25	0.25	0.43	0.00	0.56	0.56
E_{12}	0.00	0.17	0.23	0.23	0.23	0.23	0.45	0.17	0.23	0.23	0.23	0.23	0.45	0.45	0.45	0.45	0.45	0.33	0.00	0.00	0.00	0.60	0.00	0.00	0.60	0.00	0.60	0.60
E_{17}	0.25	0.54	0.13	0.11	0.25	0.22	0.22	0.38	0.13	0.22	0.25	0.60	0.11	0.54	0.60	0.54	0.60	0.47	0.11	0.13	0.22	0.11	0.22	0.10	0.20	0.11	0.11	0.20

* The eight claims in one patent were compared one by one in the focus group and the dissimilarity values were labelled as D_{ij} , e.g., the dissimilarity between claim 2 and claim 3 in the patent was D_{23} .

Appendix F: Evaluation Sheets

Table F.1 Example of the evaluation sheet (E_{12}) in focus group studies*.

Evaluator no.: ____ . Target patent: ____ . Start time: ____, Finish time: ____. Date: _____

	1	2	3	4	5	6	7	8	9	10	11	12
	Stability, reliability & security	Length, angle, area & layout	Volume, weight, intensity & capacity	Light, colour & temperature	Accuracy & measurability	Complexity & diversity	Movement, speed & time	Force & filed	Power, substance transformation	Quantity & quantity changing	Adaptability & versatility	Productivity, manufacturing, automation & repair
A1	O	O						O			O	
B2		O			O	O		O				O
C3					O	O	O		O	O	O	

* The focus group studies were carried out via collaborations with the eight evaluators, who are asked to answer this question: ‘Does this claim state something relevant with 1. Stability, 2. Length, 3. ...?’ If yes, then make a mark there; if no, then leave the place blank.

Table F.2 Development of evaluation criteria sets: E_{15} and E_{12b} .

	1	2	3	4	5	6	7	8	9	10	11	12	13	14	15
E_{15}	Force	Field	Rotating	Translating	Material*	Accurate/complex	Replaced	3D structure	Stable	Subsystem	2D arrangement	Cycle/repeated	Direction/angle	Interface	Transformation of energy/substance
E_{12b}		Field	Rotating	Translating	Material	Accurate	Replaced	Spatial layout	Balance	Sub-system/structure	Array	Cycle	Angle		

* According to the experience accumulated in the tests, some elements of the evaluation criteria are modified or added based on the TRIZ parameters such as Material, Cycle, etc.

Appendix G: Evaluation Results

Table G.1 TRIZ parameter relevance evaluation sheet of Case 1: using E_{12} parameters.

	A2	A3	A4-5	A6-7	A8	A9-10	A11	B2	B3	B4-7,14,21-23,25	B8	B9	B10-12	B13	B15-16	B17-18	B19-20	B24	B26	B27-33	C2-3	C4	C5	C6-7
A2	0.00	0.50	0.71	1.00	0.20	0.40	0.71	0.50	1.00	0.67	0.27	0.50	0.56	0.43	0.40	0.67	0.43	0.43	0.75	0.40	0.56	0.71	0.33	0.50
A3	0.50	0.00	0.14	0.33	0.40	0.20	0.43	0.25	0.33	0.67	0.27	0.50	0.33	0.43	0.40	0.67	0.43	0.43	0.50	0.40	0.33	0.43	0.33	0.50
A4-5	0.71	0.14	0.00	0.20	0.56	0.33	0.33	0.14	0.20	0.60	0.40	0.43	0.25	0.33	0.33	1.00	0.67	0.33	0.43	0.33	0.25	0.33	0.50	0.43
A6-7	1.00	0.33	0.20	0.00	0.75	0.50	0.20	0.33	0.00	0.50	0.56	0.67	0.43	0.60	0.50	1.00	1.00	0.60	0.33	0.50	0.43	0.60	0.71	0.67
A8	0.20	0.40	0.56	0.75	0.00	0.17	0.56	0.40	0.75	0.50	0.08	0.40	0.27	0.56	0.17	0.50	0.33	0.33	0.60	0.33	0.27	0.33	0.09	0.40
A9-10	0.40	0.20	0.33	0.50	0.17	0.00	0.33	0.20	0.50	0.50	0.08	0.20	0.09	0.33	0.17	0.50	0.33	0.33	0.40	0.33	0.09	0.33	0.27	0.60
A11	0.71	0.43	0.33	0.20	0.56	0.33	0.00	0.14	0.20	0.20	0.40	0.43	0.25	0.33	0.33	1.00	1.00	0.33	0.14	0.33	0.25	0.67	0.75	0.71
B2	0.50	0.25	0.14	0.33	0.40	0.20	0.14	0.00	0.33	0.33	0.27	0.25	0.11	0.14	0.20	1.00	0.71	0.14	0.25	0.20	0.11	0.43	0.56	0.50
B3	1.00	0.33	0.20	0.00	0.75	0.50	0.20	0.33	0.00	0.50	0.56	0.67	0.43	0.60	0.50	1.00	1.00	0.60	0.33	0.50	0.43	0.60	0.71	0.67
B4-7,14,21-23,25	0.67	0.67	0.60	0.50	0.50	0.50	0.20	0.33	0.50	0.00	0.56	0.67	0.43	0.60	0.50	1.00	1.00	0.20	0.33	0.50	0.43	0.60	0.71	0.67
B8	0.27	0.27	0.40	0.56	0.08	0.08	0.40	0.27	0.56	0.56	0.00	0.27	0.17	0.40	0.08	0.56	0.40	0.40	0.45	0.23	0.17	0.40	0.17	0.45
B9	0.50	0.50	0.43	0.67	0.40	0.20	0.43	0.25	0.67	0.67	0.27	0.00	0.11	0.14	0.20	0.67	0.43	0.43	0.50	0.40	0.11	0.43	0.56	0.75
B10-12	0.56	0.33	0.25	0.43	0.27	0.09	0.25	0.11	0.43	0.43	0.17	0.11	0.00	0.25	0.09	0.71	0.50	0.25	0.33	0.27	0.00	0.25	0.40	0.56
B13	0.43	0.43	0.33	0.60	0.56	0.33	0.33	0.14	0.60	0.60	0.40	0.14	0.25	0.00	0.33	1.00	0.67	0.33	0.43	0.33	0.25	0.67	0.75	0.71
B15-16	0.40	0.40	0.33	0.50	0.17	0.17	0.33	0.20	0.50	0.50	0.08	0.20	0.09	0.33	0.00	0.75	0.56	0.33	0.40	0.17	0.09	0.33	0.27	0.40
B17-18	0.67	0.67	1.00	1.00	0.50	0.50	1.00	1.00	1.00	1.00	0.56	0.67	0.71	1.00	0.75	0.00	0.20	1.00	1.00	1.00	0.71	0.60	0.43	1.00

B19-20	0.43	0.43	0.67	1.00	0.33	0.33	1.00	0.71	1.00	1.00	0.40	0.43	0.50	0.67	0.56	0.20	0.00	0.67	1.00	0.78	0.50	0.33	0.25	0.71
B24	0.43	0.43	0.33	0.60	0.33	0.33	0.33	0.14	0.60	0.20	0.40	0.43	0.25	0.33	0.33	1.00	0.67	0.00	0.43	0.33	0.25	0.33	0.50	0.43
B26	0.75	0.50	0.43	0.33	0.60	0.40	0.14	0.25	0.33	0.33	0.45	0.50	0.33	0.43	0.40	1.00	1.00	0.43	0.00	0.20	0.33	0.71	0.78	0.50
B27-33	0.40	0.40	0.33	0.50	0.33	0.33	0.33	0.20	0.50	0.50	0.23	0.40	0.27	0.33	0.17	1.00	0.78	0.33	0.20	0.00	0.27	0.56	0.45	0.20
C2-3	0.56	0.33	0.25	0.43	0.27	0.09	0.25	0.11	0.43	0.43	0.17	0.11	0.00	0.25	0.09	0.71	0.50	0.25	0.33	0.27	0.00	0.25	0.40	0.56
C4	0.71	0.43	0.33	0.60	0.33	0.33	0.67	0.43	0.60	0.60	0.40	0.43	0.25	0.67	0.33	0.60	0.33	0.33	0.71	0.56	0.25	0.00	0.25	0.43
C5	0.33	0.33	0.50	0.71	0.09	0.27	0.75	0.56	0.71	0.71	0.17	0.56	0.40	0.75	0.27	0.43	0.25	0.50	0.78	0.45	0.40	0.25	0.00	0.33
C6-7	0.50	0.50	0.43	0.67	0.40	0.60	0.71	0.50	0.67	0.67	0.45	0.75	0.56	0.71	0.40	1.00	0.71	0.43	0.50	0.20	0.56	0.43	0.33	0.00

The dissimilarity table is a triangle symmetric matrix. On the diagonal line the dissimilarity values are 0, meaning that a claim has no dissimilarity to itself. The evaluation results of other cases are available upon request.

Glossaries and Abbreviations

Glossaries

Obviousness

Explanations

The core concept in the second condition of patentability and requirements of validity of patents, meaning unessential differences in terms of the inventive concept.

Inventive concept

The idea or principle to be called inventive.

The Windsurfing/Pozzoli approach

The current authorised approach to assessing obviousness.

Abbreviations

Explanations

CGK

Common General Knowledge.

CPC

Cooperative Patent Classification.

EPC

European Patent Convention.

EPO

European Patent Office.

F-Term

File Forming Term.

IP

Intellectual Property.

IPC

International Patent Classification.

IPO

Intellectual Property Office.

IPR

Intellectual Property Right.

MDS

Multi-Dimensional Scaling.

p. or pp.

Page.

PSA

Problem-Solution Approach, the way to assess obviousness under EPC.

RPC

Reports of Patent Cases.

TP

True Positive.

TRIZ	Russian acronym, “Theoria Resheneyva Isobretatelskehuh Zadach”, translated as the Theory of Inventive Problem Solving.
TSM	Teaching-Suggestion-Motivation, the way to assess obviousness under the US patent law system.
WIPO	World Intellectual Property Organisation.

List of References

- Abbas, A., Zhang, L., Khan, S.U. (2014) A literature review on the state-of-the-art in patent analysis. *World Patent Information*, pp. 1-11.
- Allergan Inc v Sandoz Canada Inc* 2011 FC 1316, pp.57.
- Altman, D. G., Bland, J. M. (1994) Diagnostic test 1: sensitivity and specificity. *British Medical Journal*, 308, pp.1552.
- Altshuller, G. (1999) *The innovation algorithm: TRIZ, systematic innovation, and technical creativity*. Technical Innovation Centre, Worcester, MA.
- Apimed Medical Honey Ltd v Brightwake Ltd* [2011] EWPC 2, [2011] RPC 16.
- Bently, L., Maniatis, S. (1998) *Perspectives on intellectual property*. Vol.4. London: Sweet & Maxwell.
- Blake, B. F., Schulze, S., Hughes, J. M. (2003) Perceptual mapping by multidimensional scaling: a step by step primer, *Research Report in Consumer Behaviour*.
- Blake, H. C. (1968) *Black law dictionary*. 4th Edition, St. Paul, Minnesota: West Publishing Company.
- British Standard Institution (1990) *BS4821:1990 Recommendations for the Presentation of Theses and Dissertations*. Available at:
http://www.brunel.ac.uk/__data/assets/pdf_file/0006/97341/wyt_presentation.pdf
(Accessed: 15 September 2014).

Brunel University Library (2014) *Harvard Referencing Guide*. Available at:

<http://libguides.brunel.ac.uk/referencing> (Accessed: 15 September 2014).

Brunel University Library (2014) *Summon- a quick guide*. Available at:

http://www.brunel.ac.uk/__data/assets/pdf_file/0009/224838/Summon-Guide.pdf

(Accessed: 15 September 2014).

Brunel University (2014) *Thesis Guidelines*. Available at:

<http://www.brunel.ac.uk/services/graduate-school/training-development-and-support/research-students/thesis-guidelines> (Accessed: 15 September 2014).

Bogatyreva O.A., Pahl A, K., Vincent J. F.V. (2002) Enriching TRIZ with biology: The biological effects database and implications for teleology and epistemology, *ETRIA World Conference*. Strasbourg, (11), 6-8.

Cascini, G., Fantechi, A., Spinicci, E. (2004) Natural Language Processing of Patent and Technical Documentation. *Document Analysis System (6th International Workshop, DAS 2004, Florence, Italy)*, Lecture Notes in Computer Science (LNCS), 3163, pp.508-20.

Cascini, G., Zini, M. (2008) Measuring patent similarity by comparing inventions functional trees. *International Federation for Information Processing (IFIP) Vol 277, Computer-Aided Innovation (CAI)*, pp.31-42.

Ceserani, J., Greatwood, P. (1995) *Innovation & creativity*. London: Kogan Page in association with AMED.

Checkland, P., Scholes, J. (1999) *Soft systems methodology: a 30-year retrospective*. Chichester: John Wiley & Sons, Inc.

- Chen, A., Chen, R. (2007) Design patent map: an innovative measure for corporative design strategies. *Engineering Management Journal*, 19, 3, pp.14-29.
- Chen, R. (2009) Design patent map visualization display. *Expert Systems with Applications*, 36, pp. 12362-74.
- Christie, A. Gare, S. (2012) *Blackstone's statutes on intellectual property*. 11th Edition, Oxford: Oxford University Press, pp.410.
- Coelho, D.A. (2009) Matching TRIZ engineering parameters to human factors issues in manufacturing. *WSEAS Transactions on Business and Economics*, 11, 6, pp. 547-56.
- Conor v Angiotech* [2006] RPC 28.
- Cronbach, L. J. (1951) Coefficient alpha and the internal structure of tests. *Psychometrika*; 16, pp. 297-334.
- Dilts, R. and DeLozier, J. (2000) *Encyclopedia of Systemic NLP and NLP New Coding*, Capitola, California: Meta Publications. Available with limited access at: <http://nlpuniversitypress.com> (Accessed 13 February 2006).
- Drahos, P. (1996). *A philosophy of intellectual property*. Aldershot : Dartmouth.
- Dyson Appliances Ltd v Hoover Ltd* [2002] RPC 22.
- European Patent Office. (2014) *About CPC (Cooperative Patent Classification)*. Available access at: <http://www.cooperativepatentclassification.org/about.html> (Accessed 13 February 2006).

- European Patent Office. (2011) *Patent teaching kit*. 2nd Edition, Munich: European Patent Office.
- Fawcett, T. (2006) An introduction to ROC analysis. *Pattern Recognition Letters*, 27, pp. 861–874.
- Feist Publications, Inc., v. Rural Telephone Service Co.* 1991 499 US 340.
- Gadd, K. (2011) *TRIZ for Engineers: Enabling Inventive Problem Solving*. West Sussex: John Wiley & Sons, Ltd.
- Genentech Inc's Patent [1989] RPC 147 (CA) 153.
- General Tire & Rubber Co v Firestone Tyre & Rubber Co Ltd* [1972] RPC 457.
- Glover, R., Murphy, P. (2013) *Murphy on Evidence*. 3rd Edition, Oxford: Oxford University Press.
- Golafshani, N. (2003) Understanding Reliability and Validity in Qualitative Research. *The Qualitative Report*, 8, pp. 597-607.
- Griffin, A., Somermeyer, S. (2007) *The PDMA toolbook 3 for new product development*. Indianapolis: John Wiley & Sons, Inc.
- Gu, Z. (2000) *Argument and analysis*, Beijing: People's Publishing House.
- European Patent Office. (2013) *Guidelines for Examination in European Patent Office and Glossary*. Available at: http://www.epo.org/law-practice/legal-texts/html/guidelines/e/f_v_2.htm, <http://www.epo.org/service-support/glossary.html#t>, and http://www.epo.org/law-practice/legal-texts/html/guidelines/e/f_iv_3_8.htm (Accessed: 15 September 2014).

Hair, J. F., Andeson, R. E., Tatham, R. L., Black, W. C. (1995) *Multivariate data analysis with readings*. 4th Edition. Prentice-Hall International, New Jersey.

Hegel, G. W. F. (1816) *Wissenschaft der Logik* (in Chinese, translated by Lin, H. pressed in 1980), Beijing: The Commercial Press.

International Organisation for Standardisation. (1997) *ISO/IEC directives*. Available at: <http://std.dkuug.dk/JTC1/sc22/WG9/isodir3.pdf> (Accessed: 15 September 2014).

Iwasaki, S. (2008) *Japanese classification system (FI, F-term)/ Quality of Reclassification*. Available at: www.wipo.int/edocs/mdocs/.../en/ipc.../ipc_wk_ge_08_s_iwasaki.ppt (Accessed: 15 September 2014).

Janssens, F.; Leta, J.; Glänzel, W.; De Moor, B. (2006) Towards mapping library and information science. *Information Processing and Management*, 42, pp. 1614-42.

Japan Patent Office (JPO). Guide book for practical use of patent map for each technology field. *Invention Research Institute, Japan Institute of Invention and Innovation*, 2000.

Jones E., Harrison D. (2000) 'Investigating the use of TRIZ in Eco-innovation' *The TRIZ Journal*, The TRIZ Institute.

Juan, W. C. (2006) *New model for international design protection* (PhD thesis). Brunel University.

Kant, I. (1781) *Critique of Pure Reason*. (in Chinese edited by Yang, Z. and Deng, X. *Kant's The Three Critiques*, pressed in 2001), Beijing: People's Publishing House.

KCI Licensing Inc & Ors v Smith & Nephew Plc & Ors [2010] EWCA Civ 1260.

Kemp, J. A. (1983) *Patent claim drafting and interpretation*, London: Oyez Longman Publishing Limited.

Kim, Y. G., Suh, J. H., Park, S. C. (2007) Visualization of patent analysis for emerging technology. *Expert Systems with Applications*, 34, pp. 1804-12.

Kline, P. (2000) *The handbook of psychological testing*. 2nd edition. London: Routledge.

KSR Int'l Co. v. Teleflex, Inc., 2007 550 US 398.

Li, J. (2008) *The Innovation and Inspiration of the Non-Obviousness Standard of Invention Patent in the U.S.* (Dissertation). The East China University of Political Science and Law.

Li, S. (2002) *From system to chaos*, Guilin: Guangxi Normal University Press.

Li, Z., Atherton, M., Harrison, D. (2014) Identifying patent conflict: TRIZ-Led Patent Mapping. *World Patent Information*, 39.

Li, Z., Tate, D., Lane, C., Adams, C. (2014) A framework for automatic TRIZ level of invention estimation of patents using natural language processing, knowledge-transfer and patent citation metrics. *Computer-Aided Design*, 44, pp. 987-1010.

Liang, Y., Tan, R., Wang, C., Li, Z. (2009) Computer-aided classification of patents oriented to TRIZ. *Proceedings of the 2009 IEEE IEEM*.

Liparas, D., Moutzidou, A., Vrochidis, S., Kompatsiaris, I. (2014) Concept-oriented labelling of patent images based on random forests and proximity-driven

generation of synthetic data. *Proceedings of the 25th International Conference on Computational Linguistics*, pp.25-32.

Mann, D. (2001) An introduction to TRIZ: The Theory of Inventive Problem Solving. *Creative and Innovation Management-TRIZ*, 10, pp. 123-5.

Mann, D.L., Dewulf, S. (2003) Updating TRIZ—1985-2002 Patent Research findings, *TRIZCON'03, Philadelphia*.

May, C. Sell, S.K. (2006) *Intellectual property rights: a critical history*. London: Lynne Rienner.

Miller, R., Burkill, G., Birss, J., Campbell, D. (2010) *Terrell on the law of patents*. 17th Edition. London: Sweet & Maxwell Limited.

Molnlycke AB v Procter & Gamble Ltd [1994] RPC 49.

Nokia v Ipcom [2010] EWHC 3482.

Oxford University, Faculty of Law (2006) *Oxford Standard for the Citation of Legal Authorities*. Available at: <http://denning.law.ox.ac.uk/published/oscola.shtml>
(Accessed: 15 September 2014).

Oxford University Press (2014) *Oxford English Dictionary*. Available at:
<http://www.oed.com> (Accessed: 15 September 2014).

Park, H., Yoon, J., Kim, K. (2012) Identifying patent infringement using SAO based semantic technological similarities. *Scientometrics*; 90, pp. 515–29.

Powers, D.M.W. (2007) Evaluation: from precision, recall and F-factor to ROC, informedness, markedness & correlation. *The 2003 International Cognitive*

Science Conference and the 2007 Human Communication Science Summer Fest. Flinders University, Adelaide, Australia. Technical Report SIE-07-001.

Pozzoli SPA v BDMO SA [2007] EWCA Civ 588.

Rao, M. (2008) *Philosophical reflections on theories of contemporary western intellectual property*. Beijing: Science Press.

Ren, X, S., Yu, X, L. (2011) *Multi-dimensional statistical analysis*. 2nd Edition. Beijing: China Statistics Press.

Reid, B. C. (1999) *A practical guide to patent law*. 3rd Edition, London: Sweet & Maxwell Limited.

SABAF SpA v MFI Furniture Centres Ltd [2005] RPC 10.

Smith, G. V., Parr, R.L. (2005) *Intellectual property: valuation, exploitation, and infringement damages*. Indianapolis: John Wiley & Sons, Inc.

Sun, J., Zhao, H., Zhao, Y., Hu. F. (2011) Empirical study of corporate social responsibility overlap based on multidimensional scaling analysis. *Mathematics in Practice and Theory*, 41, 9, pp.106-14.

Suh, J. H., Park, S. C. (2006) A new visualisation method for patent map: application to Ubiquitous computing technology. *ADMA 2006, LNAI*, 4093, pp.566-73.

Technical Board of Appeal (TBA) decision in T 1054/05.

Torgerson, W. S. (1958) *Theory and methods of scaling*. New York: John Wiley and Sons, Inc.

TRIZ Journal. (2014) *The 39 Features of Altshuller's Contradiction Matrix*. Available at: <http://www.triz-journal.com/archives/1998/11/d/> (Accessed: 15 September 2014).

Uchida, H., Mano, A., Yukawa, T. (2004) Patent map generation using concept-based vector space model. *Working Notes of NTCIR-4*.

UK Intellectual Property Office (2014) *Business guidance on changes to the law on designs*. Available at: https://www.gov.uk/government/uploads/system/uploads/attachment_data/file/323145/changes-to-designs-law.pdf (Accessed: 15 September 2014).

UK Intellectual Property Office. (2014) *Manual of Patent Practice (MoPP) 2014*. Available at: <http://www.ipo.gov.uk/downloads/practice-manual.pdf> (Accessed: 15 September 2014).

Virgin v Zodiac [2009] EWCA Civ 1062.

Virgin v Zodiac [2013] UKSC 46.

Walton, D.N. (2001) Abductive, presumptive and plausible arguments. *Informal Logic*, 21, 2: pp.141-169.

Wang, R. (2008) *Review of modern western philosophy*, Shanghai: Academia Press.

Windsurfing International INC v Tabur Marine LTD [1985] RPC 59.

World Intellectual Property Organisation. (2014) *Member states*. Available at: <http://www.wipo.int/members/en> (Accessed: 15 September 2014).

Yamashina, H., Ito, T., Kawada, H. (2002) Innovative product development process by integrating QFD and TRIZ. *International Journal of Production Research*, 40, pp.1031-50.

Yoon, B. U., Yoon, C. B., Park, Y. T. (2002) On the development and application of a self-organizing feature map-based patent map. *R&D Management*, 32, 4, pp. 291-300.

Zelanshi, P., Fisher, M.P. (1996) *Design principles and problems*, 2nd Edition, Harcourt Brace College Publishers.

Bibliography

Hegel, G. W. F. (1819) *The elements of philosophy of rights* (in Chinese, pressed in 2013). Beijing: The Commercial Press.

Author's Publication

Li, Z., Atherton, M., Harrison, D. 2014. Identifying Patent Conflicts: TRIZ-Led Patent Mapping, *World Patent Information*, 39.

Li, Z., Atherton, M., Corporate patent strategy for open innovation: a game theory model based on technical features in patents, *the 11th International Patent Information Conference and Exposition (IPI ConfEx)*, Berlin, Germany; 2th-5th, March, 2014.

Li, Z., Atherton, M., A top-down approach to patent mapping, *the International Information Conference on Search, Data Mining and Visualization (II-SDV)*, Nice, France; 15th -16th April, 2013.

Postscript

The beginning and basis of this research is to admit that technical features described in patent claims (productivities) and exclusive rights constructed by claims (relationships between producers) can be seen as two corresponding daseins so that they can be mapped by each other. The purpose of the research is to identify, evaluate and visualise conflicts between patent claims, in order to contribute to a more transparent and efficient method for assessing patent **obviousness**, and thereby to promote open and fair environment for capital competitions based on innovation of technology.

All in all, assessing conflicts between patents is to harmonise conflicts between people. To achieve more harmonies, it is crucial to find mediation to see similarities in differences while recognise differences from similarities. That is why the scientific way to establish certain evaluation criteria (mediation) has been valued so much in this research. Admittedly, the appropriate mathematical tools, i.e. MDS and other statistical methods, should be re-considered and improved in the future work, although they are not the main issue. The major theme is patent **obviousness** and its assessment. Patent **obviousness** is a concept that describes temporary dissimilarities between productivities, revealing relations of objective technologies based on subjective judgements. Assessing **obviousness** is an interest-driven interactive game that reveals relationships between producers. This game has been well-designed and amended by governments and their judicial systems to regularise different producers in capital markets, in order to balance interests between competitions and monopolies. For justifying **obviousness**, it is hard to achieve a global uniform standard; there is a lack of concise and efficient method; and consistent judgments are not easy to guarantee.

The key reason of these existing problems is that the idea of **non-obviousness** remains at the stage of a pure relativity (negation) of **obviousness**. The dialectical movement between the denotation and connotation of this idea is still going on, meaning that its sufficient speciality will be sublated more completely; and its necessary generality (negation of negation) will be achieved finally. Then, a new era will begin.

Index

Keywords	Page
Absolute similarity and relative similarity	033
Criteria-Based Patent Mapping	030
Elements of the inventive concept	030
Inventive concept	108
Inventive step	108
MDS (Multi-Dimensional Scaling)	018
Obviousness	105
Patents Act 1977	106
Patent claim	107
Patent claim conflict	001
Patent mapping	015
Patent validity (or, validity of patents)	108
Technical feature	108
TP (True Positive)	051
TRIZ (Theory of Inventive Problem Solving)	022
TRIZ-Led Patent Mapping	034
Windsurfing/Pozzoli approach	109

Copyright © and Moral Rights for this thesis are retained by the author.

A copy can be downloaded for personal non-commercial research or study, without prior permission or charge. This thesis cannot be reproduced or quoted extensively from without first obtaining permission in writing from the copyright holder. The content must not be changed in any way or sold commercially in any format or medium without the formal permission of the copyright holders.

When referring to this work, full bibliographic details including the author, title, awarding institution and date of the thesis must be given.

